

LBTN3100DPTUG

S-LBTN3100DPTUG

NPN Power transistors

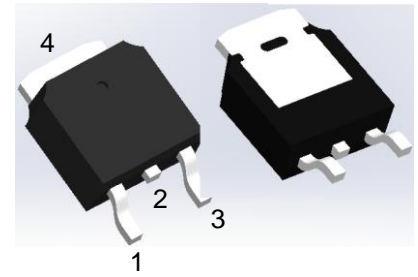

TO-252

1. FEATURES

- High collector current
- Low collector-emitter saturation voltage
- We declare that the material of product compliance with RoHS requirements and Halogen Free.
- S-prefix for automotive and other applications requiring unique site and control change requirements; AEC-Q101 qualified and PPAP capable.

2. DEVICE MARKING AND ORDERING INFORMATION

Device	Marking	Shipping
LBTN3100DPTUG	N31	2500/Tape&Reel

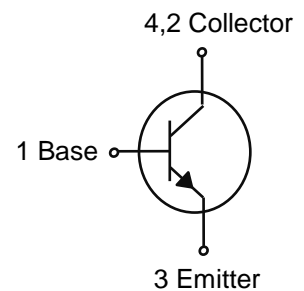

3. MAXIMUM RATINGS(Ta = 25°C)

Parameter	Symbol	Limits	Unit
Collector–Emitter Voltage	VCEO	100	V
Collector–Base Voltage	VCBO	100	V
Emitter–Base Voltage	VEBO	5	V
Collector Current — Continuous	IC	3	A
Peak collector current (tp ≤ 10 ms)	ICM	5	A
Base current	IB	1	A
Total Power Dissipation (Note 1) @ TA = 25°C	PD	1.75	W
Junction Temperature	Tj	150	°C
Storage Temperature Range	Tstg	-55~+150	°C

4. THERMAL CHARACTERISTICS

Parameter	Symbol	Limits	Unit
Thermal Resistance, Junction–to–Ambient(Note 1)	RθJA	71.4	°C/W

1. These ratings are applicable when surface mounted on the minimum pad sizes recommended.

5. ELECTRICAL CHARACTERISTICS (Ta= 25°C)

Characteristic	Symbol	Min.	Typ.	Max.	Unit
Collector–Emitter Breakdown Voltage (IC=10mA, IB=0)	VBR(CEO)	100	-	-	V
Collector–Base Breakdown Voltage (IC = 100 μA, IE = 0)	VBR(CBO)	100	-	-	V
Emitter–Base Breakdown Voltage (IE=100uA,IC=0)	VBR(EBO)	5	-	-	V
Collector Cutoff Current (VCB=100V, IE=0)	ICBO	-	-	500	nA
Collector-Emitter Cutoff Current (VCE=60V,IB=0)	ICEO	-	-	50	μA
Emitter CutOff Current (VEB=5V, IC=0)	IEBO	-	-	500	nA
DC Current Gain (VCE=4V, IC=1A) (VCE=4V, IC=3A)	HFE	25 10	- -	- 100	
Collector–Emitter Saturation Voltage (IC = 3A, IB = 0.3A) (IC = 5A, IB = 0.5A)	VCE(sat)	- -	- -	1.2 1.5	V
Base–Emitter Saturation Voltage (IC = 3A, IB = 0.3A)	VBE(sat)	-	-	1.6	V
Base–Emitter On Voltage (IC = 3A, VCE=4V)	VBE(on)	-	-	1.8	V
Transition Frequency (VCE =10V, IC =500mA, f=1MHz)	fT	3	-	-	MHz

6.ELECTRICAL CHARACTERISTICS CURVES

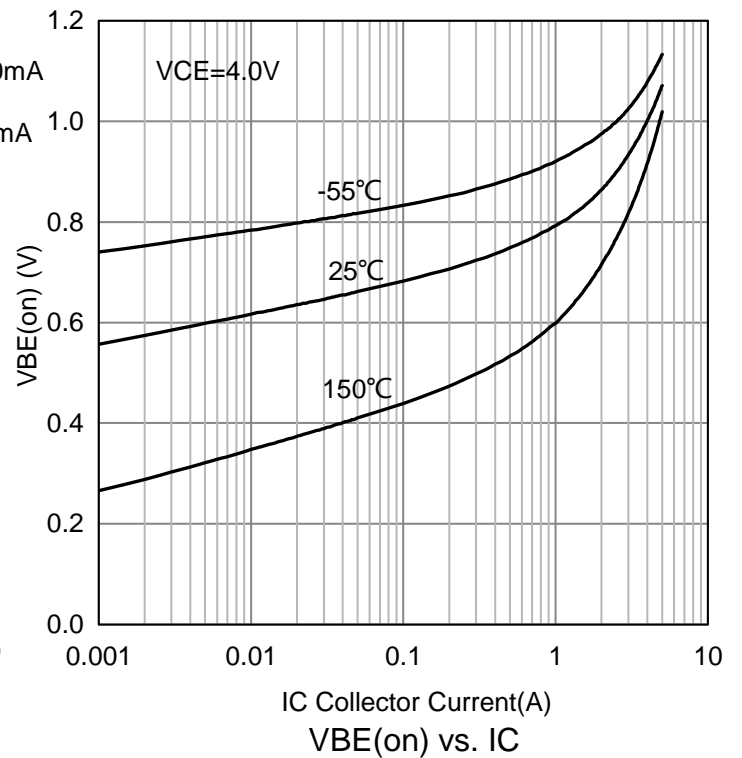
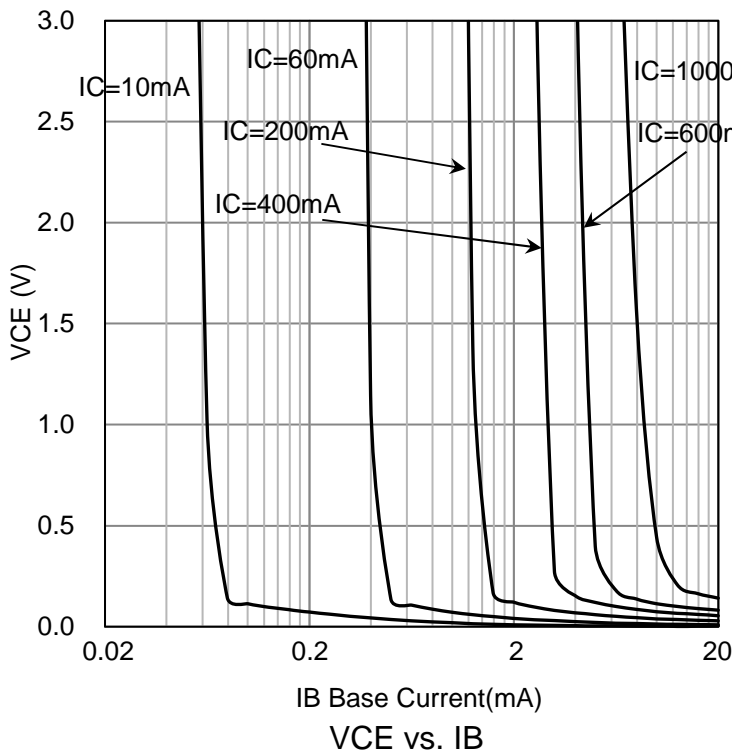
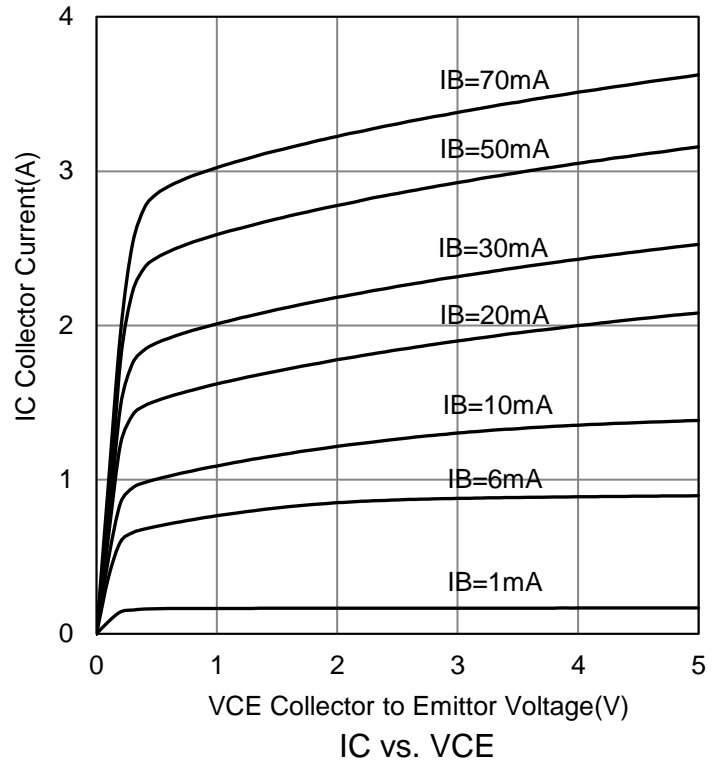
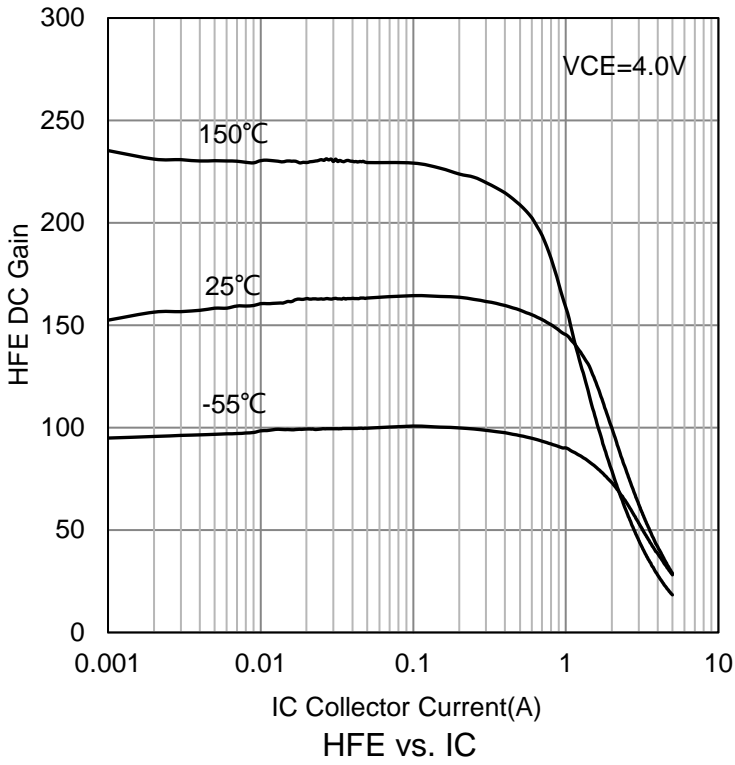

6.ELECTRICAL CHARACTERISTICS CURVES(Con.)

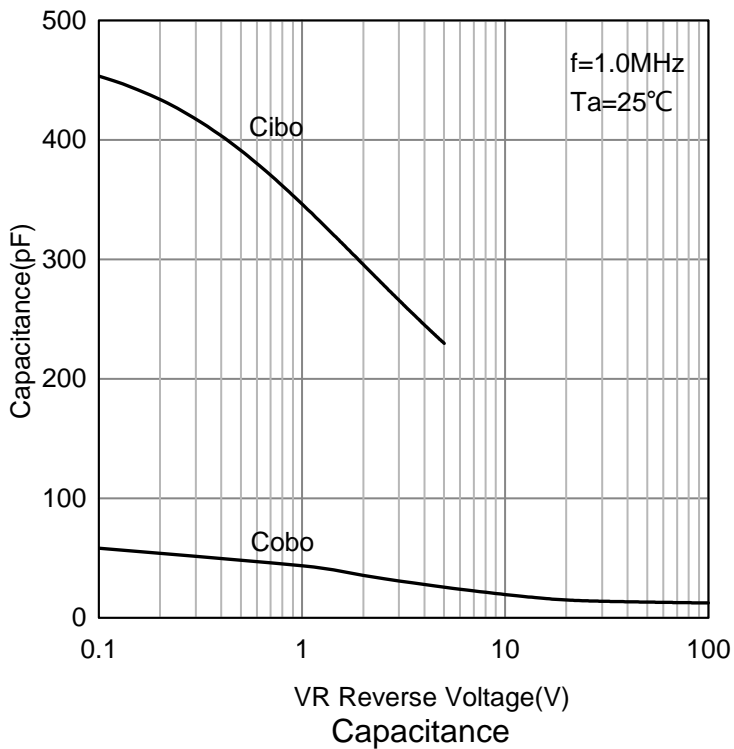
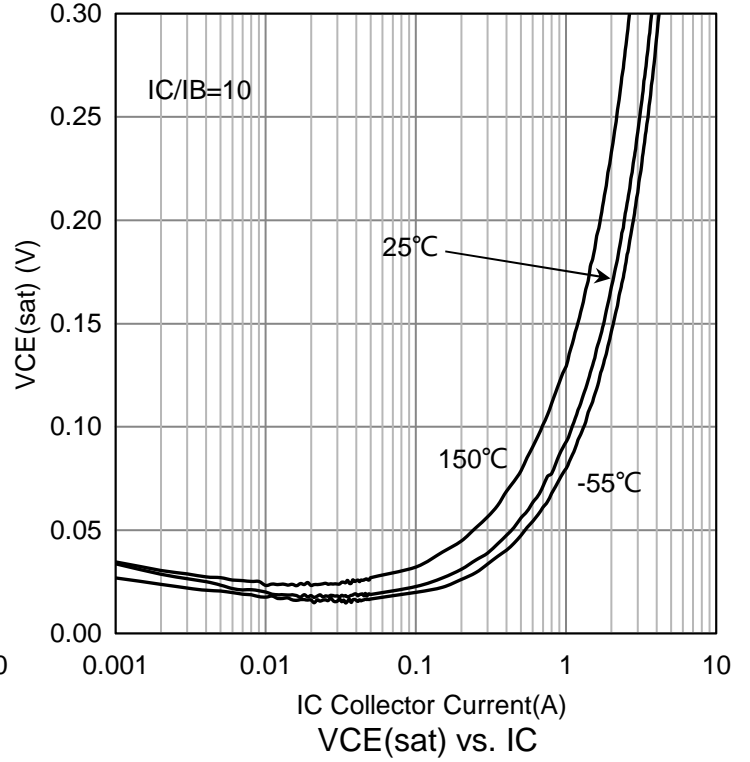
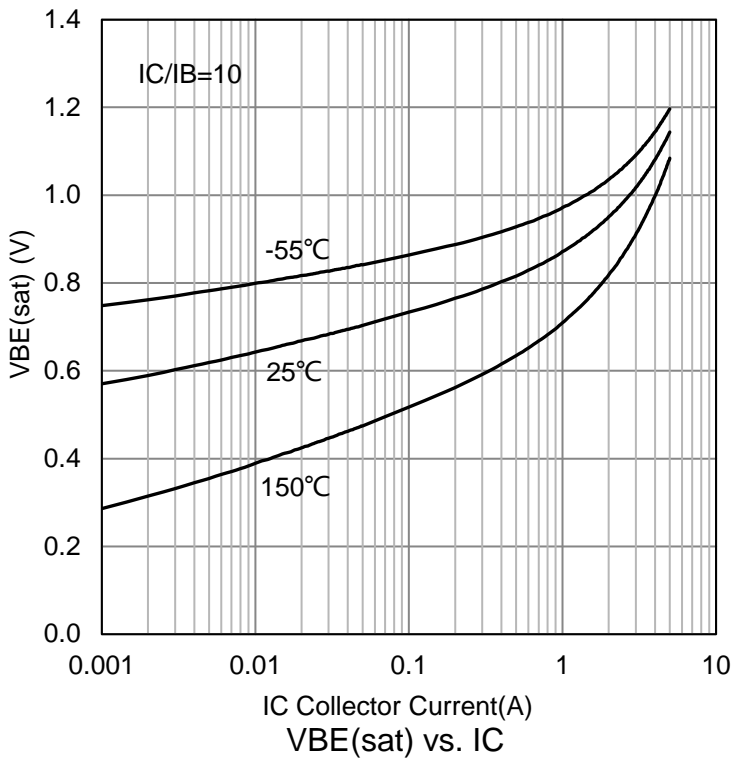

7.OUTLINE AND DIMENSIONS

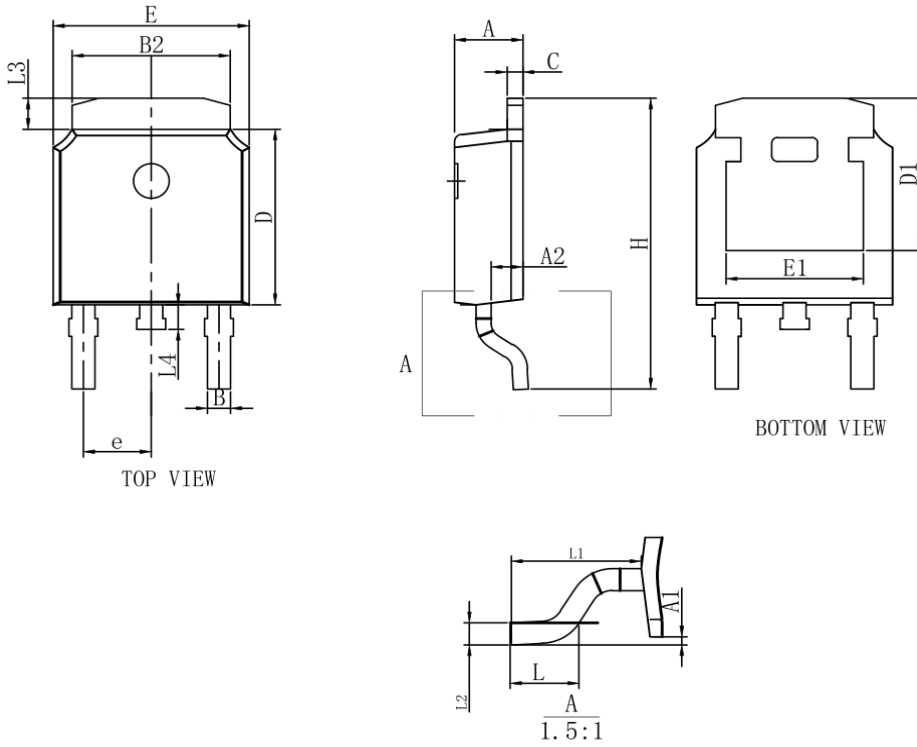

DIM	MILLIMETERS		
	MIN	NOM	MAX
A	2.15	2.30	2.45
A1	-	-	0.20
A2	0.90	1.07	1.17
B	0.68	0.78	0.88
B2	5.20	5.33	5.46
D	5.90	6.10	6.30
D1	5.30REF		
E	6.40	6.60	6.80
E1	4.63	4.83	5.03
e	2.286BSC		
H	9.85	10.10	10.35
L	1.30	1.50	1.70
L1	2.90REF		
L2	0.51BSC		
L3	0.88	1.08	1.28
L4	0.55	0.80	1.05

8.SOLDERING FOOTPRINT

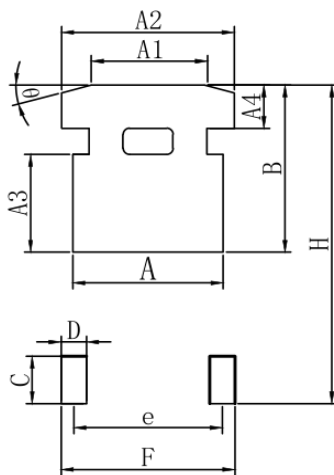

DIM	MIN(mm)
A	6.03
A1	4.50
A2	6.46
A3	4.10
A4	2.37
B	6.50
C	2.50
D	1.68
e	4.80
H	12.35
F	5.95

DISCLAIMER

- Curve guarantee in the specification. The curve of test items with electric parameter is used as quality guarantee. The curve of test items without electric parameter is used as reference only.
- Before you use our Products for new Project, you are requested to carefully read this document and fully understand its contents. LRC shall not be in any way responsible or liable for failure, malfunction or accident arising from the use of any LRC's Products against warning, caution or note contained in this document.
- All information contained in this document is current as of the issuing date and subject to change without any prior notice. Before purchasing or using LRC's Products, please confirm the latest information with a LRC sales representative.

单击下面可查看定价，库存，交付和生命周期等信息

[>>LRC\(乐山无线电\)](#)