

General Purpose Transistors

PNP Silicon

- S- Prefix for Automotive and Other Applications Requiring Unique Site and Control Change Requirements; AEC-Q101 Qualified and PPAP Capable.
- We declare that the material of product compliance with RoHS requirements.

● DEVICE MARKING AND ORDERING INFORMATION

| Device | Marking | Shipping |
|--------------------------------|---------|-----------------|
| L2SA1774QT1G S-L2SA1774QT1G | FQ | 3000/Tape&Reel |
| L2SA1774QT3G S-L2SA1774QT3G | FQ | 10000/Tape&Reel |
| L2SA1774RT1G S-L2SA1774RT1G | FR | 3000/Tape&Reel |
| L2SA1774RT3G S-L2SA1774RT3G | FR | 10000/Tape&Reel |
| L2SA1774ST1G S-L2SA1774ST1G | FS | 3000/Tape&Reel |
| L2SA1774ST3G S-L2SA1774ST3G | FS | 10000/Tape&Reel |

L2SA1774QT1G
Series
S-L2SA1774QT1G
Series

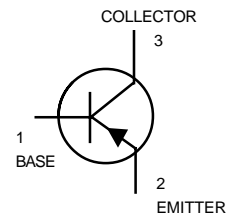
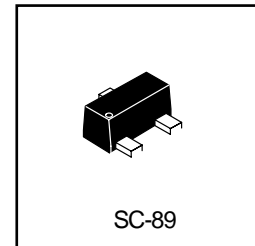

● Absolute maximum ratings (Ta=25°C)

| Parameter | Symbol | Limits | Unit |
|-----------------------------|------------------|----------|--------|
| Collector-base voltage | V _{CB0} | -60 | V |
| Collector-emitter voltage | V _{CEO} | -50 | V |
| Emitter-base voltage | V _{EBO} | -6 | V |
| Collector current | I _c | -0.15 | A (DC) |
| Collector power dissipation | P _c | 0.15 | W |
| Junction temperature | T _j | 150 | °C |
| Storage temperature | T _{stg} | -55~+150 | °C |

● Electrical characteristics (Ta=25°C)

| Parameter | Symbol | Min. | Typ. | Max. | Unit | Conditions |
|--------------------------------------|----------------------|------|------|------|------|---|
| Collector-base breakdown voltage | BV _{CB0} | -60 | - | - | V | I _c =-50μA |
| Collector-emitter breakdown voltage | BV _{CEO} | -50 | - | - | V | I _c =-1μA |
| Emitter-base breakdown voltage | BV _{EBO} | -6 | - | - | V | I _E =-50μA |
| Collector cutoff current | I _{CB0} | - | - | -0.1 | μA | V _{CB} =-60V |
| Emitter cutoff current | I _{EBO} | - | - | -0.1 | μA | V _{EB} =-6V |
| Collector-emitter saturation voltage | V _{CE(sat)} | - | - | -0.5 | V | I _c /I _E =-50mA/-5mA |
| DC current transfer ratio | h _{FE} | 120 | - | 560 | - | V _{CE} =-6V, I _c =-1mA |
| Transition frequency | f _t | - | 140 | - | MHz | V _{CE} =-12V, I _E =2mA, f=30MHz |
| Output capacitance | C _{ob} | - | 4.0 | 5.0 | pF | V _{CB} =-12V, I _E =0A, f=1MHz |

● h_{FE} values are classified as follows:

| Item | Q | R | S |
|-----------------|---------|---------|---------|
| h _{FE} | 120~270 | 180~390 | 270~560 |

L2SA1774QT1G
Series
S-L2SA1774QT1G
Series

●Electrical characteristic curves

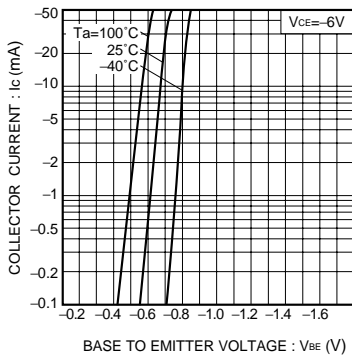

Fig.1 Grounded emitter propagation characteristics

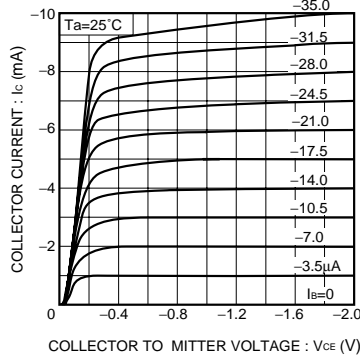

Fig.2 Grounded emitter output characteristics (I)

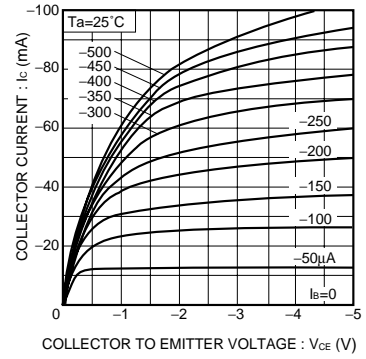

Fig.3 Grounded emitter output characteristics (II)

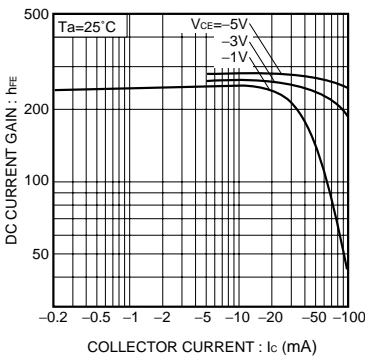

Fig.4 DC current gain vs. collector current (I)

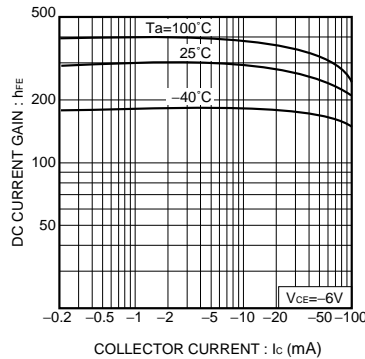

Fig.5 DC current gain vs. collector current (II)

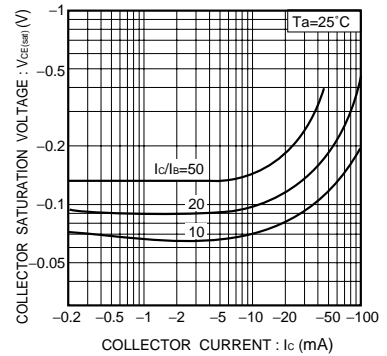

Fig.6 Collector-emitter saturation voltage vs. collector current (I)

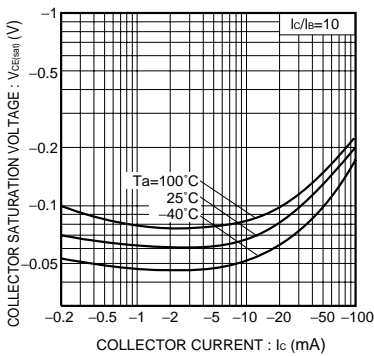

Fig.7 Collector-emitter saturation voltage vs. collector current (II)

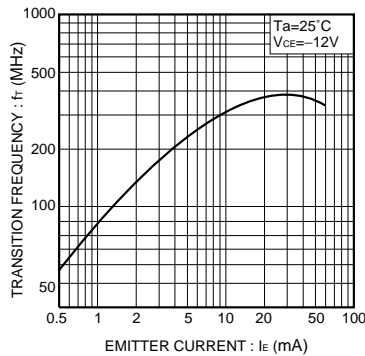

Fig.8 Gain bandwidth product vs. emitter current

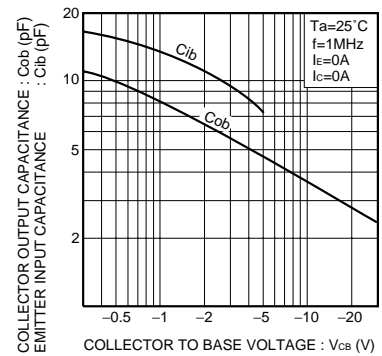
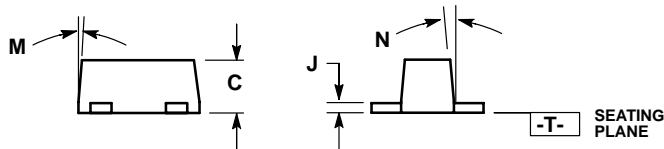
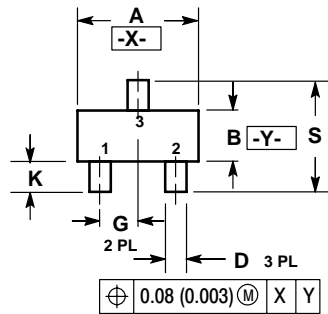

Fig.9 Collector output capacitance vs. collector-base voltage
Emitter input capacitance vs. emitter-base voltage

L2SA1774QT1G
Series
S-L2SA1774QT1G
Series

SC-89



NOTES:

1. DIMENSIONING AND TOLERANCING PER ANSI Y14.5M, 1982.
2. CONTROLLING DIMENSION: MILLIMETERS
3. MAXIMUM LEAD THICKNESS INCLUDES LEAD FINISH THICKNESS. MINIMUM LEAD THICKNESS IS THE MINIMUM THICKNESS OF BASE MATERIAL.
4. 463C-01 OBSOLETE, NEW STANDARD 463C-02.

| DIM | MILLIMETERS | | | INCHES | | |
|-----|-------------|------|------|-----------|-------|-------|
| | MIN | NOM | MAX | MIN | NOM | MAX |
| A | 1.50 | 1.60 | 1.70 | 0.059 | 0.063 | 0.067 |
| B | 0.75 | 0.85 | 0.95 | 0.030 | 0.034 | 0.040 |
| C | 0.60 | 0.70 | 0.80 | 0.024 | 0.028 | 0.031 |
| D | 0.23 | 0.28 | 0.33 | 0.009 | 0.011 | 0.013 |
| G | 0.50 BSC | | | 0.020 BSC | | |
| H | 0.53 REF | | | 0.021 REF | | |
| J | 0.10 | 0.15 | 0.20 | 0.004 | 0.006 | 0.008 |
| K | 0.30 | 0.40 | 0.50 | 0.012 | 0.016 | 0.020 |
| L | 1.10 REF | | | 0.043 REF | | |
| M | --- | --- | 10 ° | --- | --- | 10 ° |
| N | --- | --- | 10 ° | --- | --- | 10 ° |
| S | 1.50 | 1.60 | 1.70 | 0.059 | 0.063 | 0.067 |

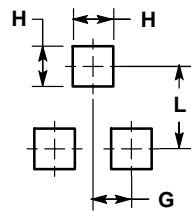

RECOMMENDED PATTERN OF SOLDER PADS

单击下面可查看定价，库存，交付和生命周期等信息

[>>LRC\(乐山无线电\)](#)