

L2SC2412KQLT1G

S-L2SC2412KQLT1G

1. FEATURES

- We declare that the material of product compliance with RoHS requirements and Halogen Free.
- S- prefix for automotive and other applications requiring unique site and control change requirements; AEC-Q101 qualified and PPAP capable.

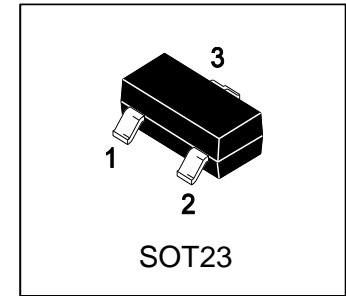

2. DEVICE MARKING AND ORDERING INFORMATION

Device	Marking	Shipping
L2SC2412KQLT1G	BQ	3000/Tape&Reel
L2SC2412KQLT3G	BQ	10000/Tape&Reel

3. MAXIMUM RATINGS(Ta = 25°C)

Parameter	Symbol	Limits	Unit
Collector-Emitter Voltage	V _{CEO}	50	V
Collector-Base voltage	V _{CBO}	60	V
Emitter-Base Voltage	V _{EBO}	7	V
Collector current —Continuous	I _C	150	mA
Collector power dissipation	PC	200	mW
Junction temperature	T _j	150	°C
Storage temperature	T _{stg}	-55~+150	°C

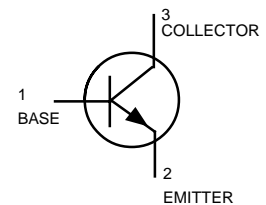

4. ELECTRICAL CHARACTERISTICS (Ta= 25°C)

Characteristic	Symbol	Min.	Typ.	Max.	Unit
Collector-Emitter Breakdown Voltage (I _C = 1.0mA)	V(BR)CEO	50	-	-	V
Emitter-Base Breakdown Voltage (I _E = 50μA)	V(BR)EBO	7	-	-	V
Collector-Base Breakdown voltage (I _C = 50μA)	V(BR)CBO	60	-	-	V
Collector Cutoff Current (V _{CB} = 60 V)	I _{CBO}	-	-	0.1	μA
Emitter Cutoff Current (V _{EB} = 7V)	I _{EBO}	-	-	0.1	μA
Collector-Emitter Saturation Voltage (I _C =50 mA, I _B =5mA)	V _{CE(sat)}	-	-	0.4	V
DC current transfer ratio (V _{CE} = 6 V, I _C = 1mA)	h _{FE}	120	-	270	
Transition frequency (V _{CE} = 12 V, I _E = 2mA, f = 30MHz)	f _T	-	180	-	MHz
Output capacitance (V _{CB} = 12 V, I _E = 0A, f = 1MHz)	C _{ob}	-	2	3.5	pF

5.ELECTRICAL CHARACTERISTICS CURVES

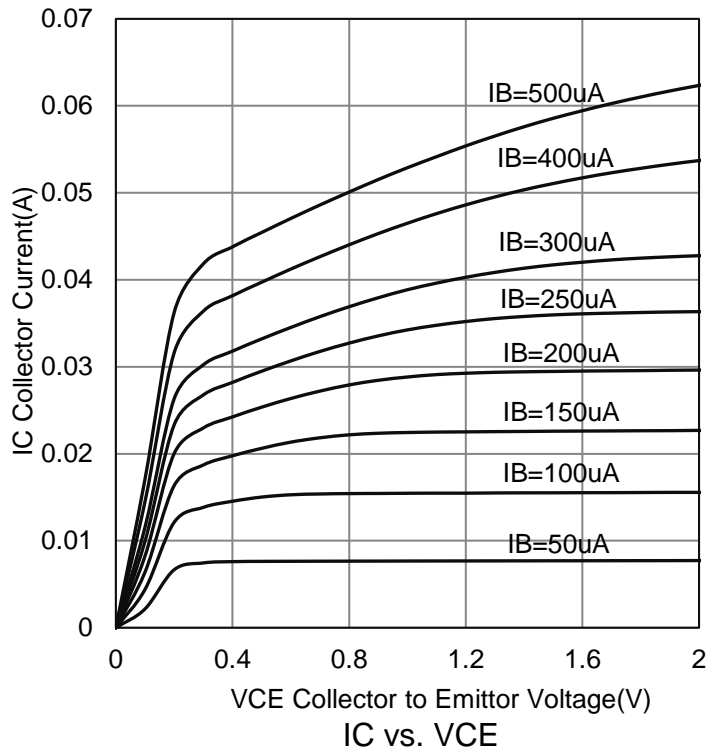
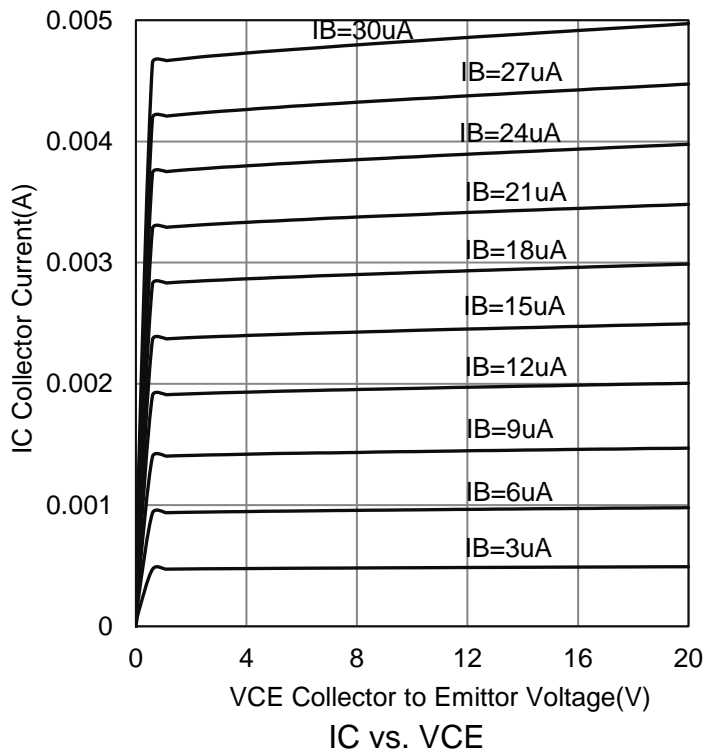
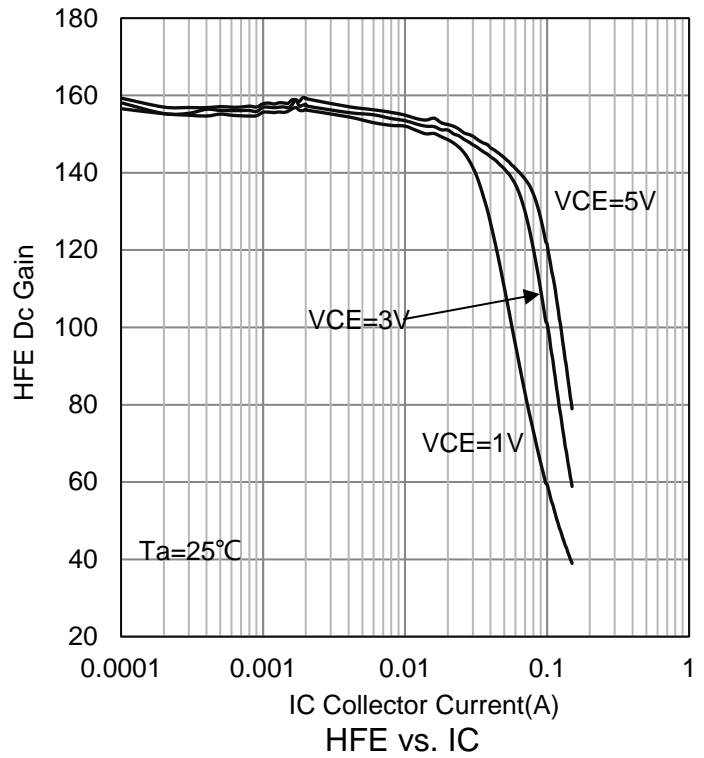
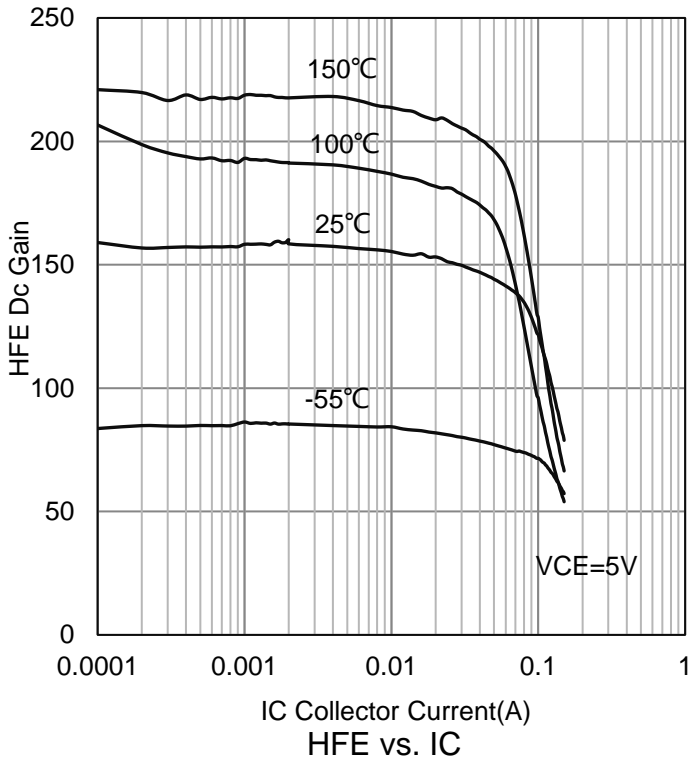

5.ELECTRICAL CHARACTERISTICS CURVES(Con.)

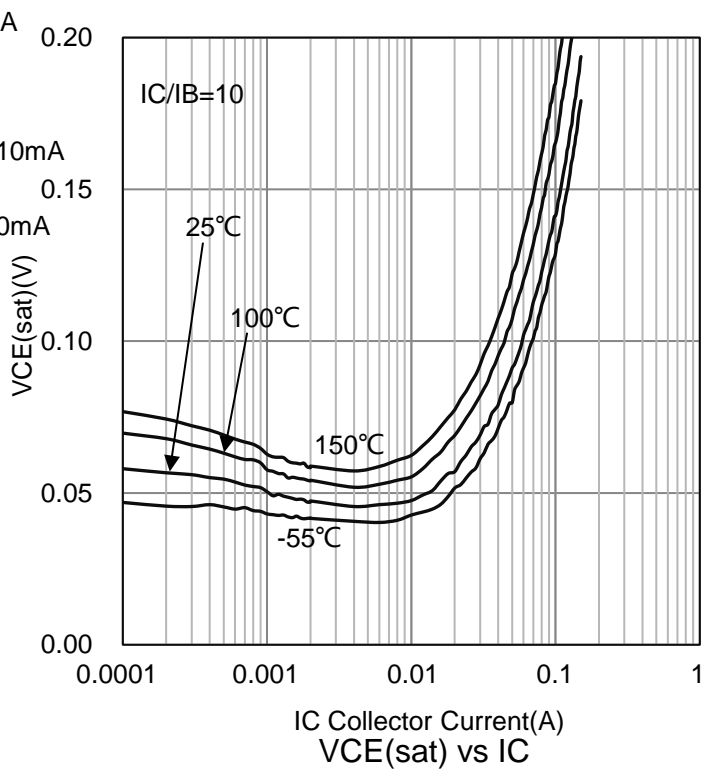
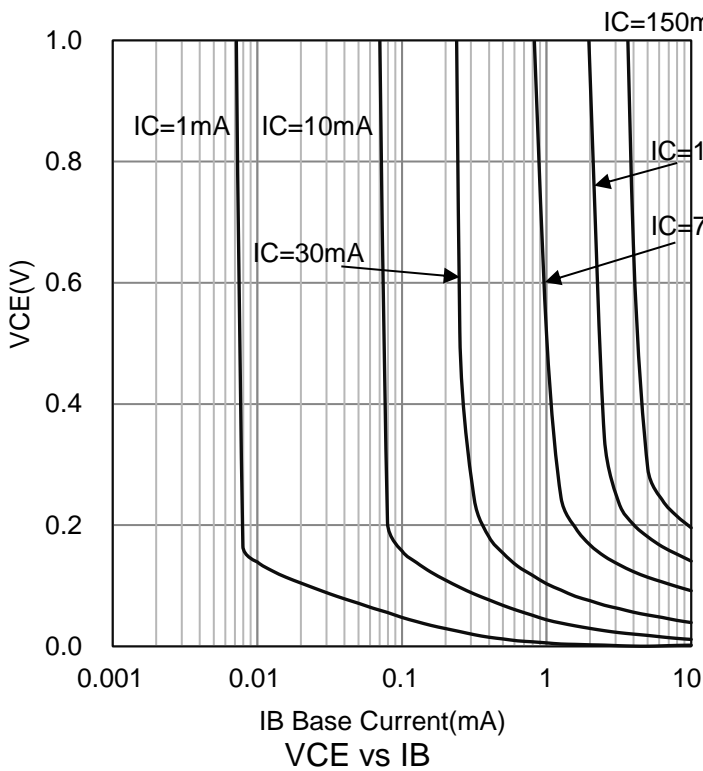
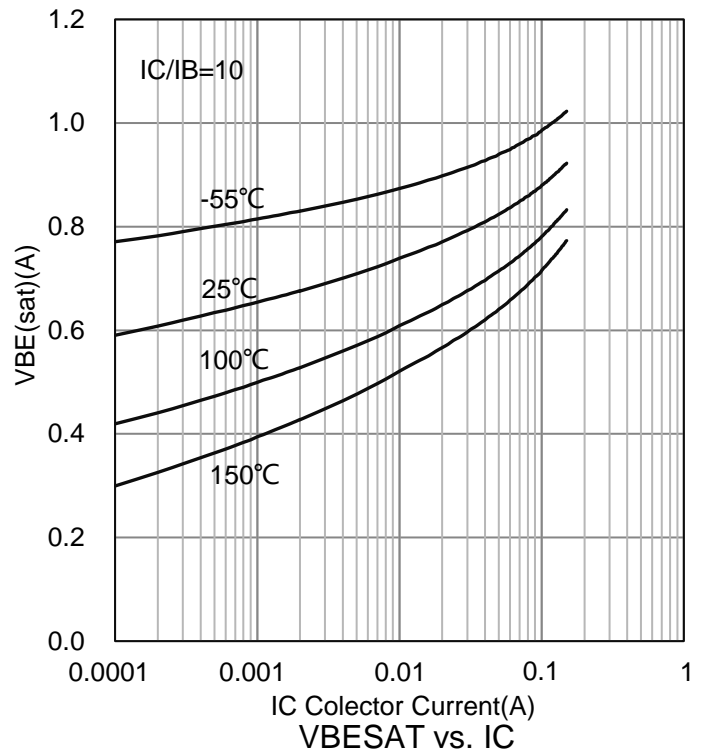
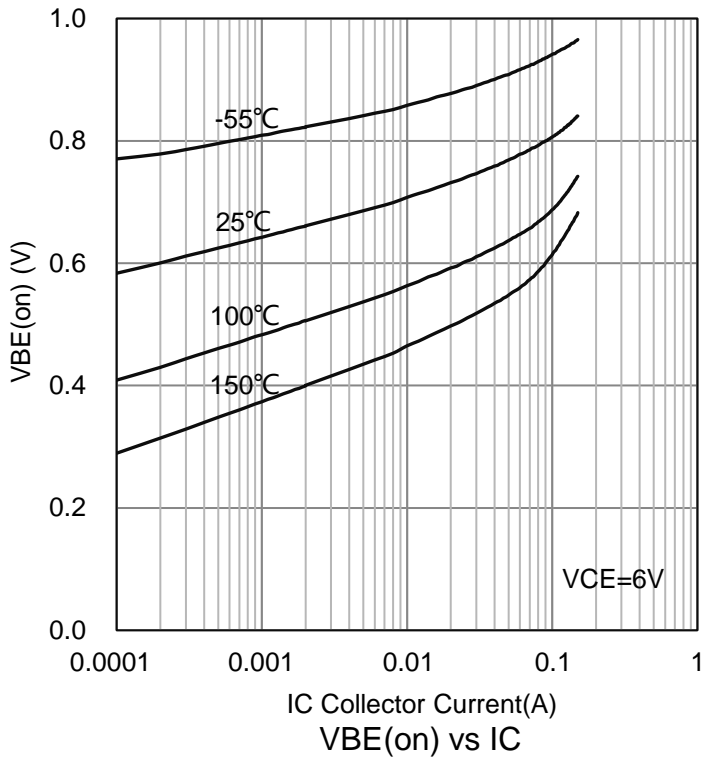

5.ELECTRICAL CHARACTERISTICS CURVES(Con.)

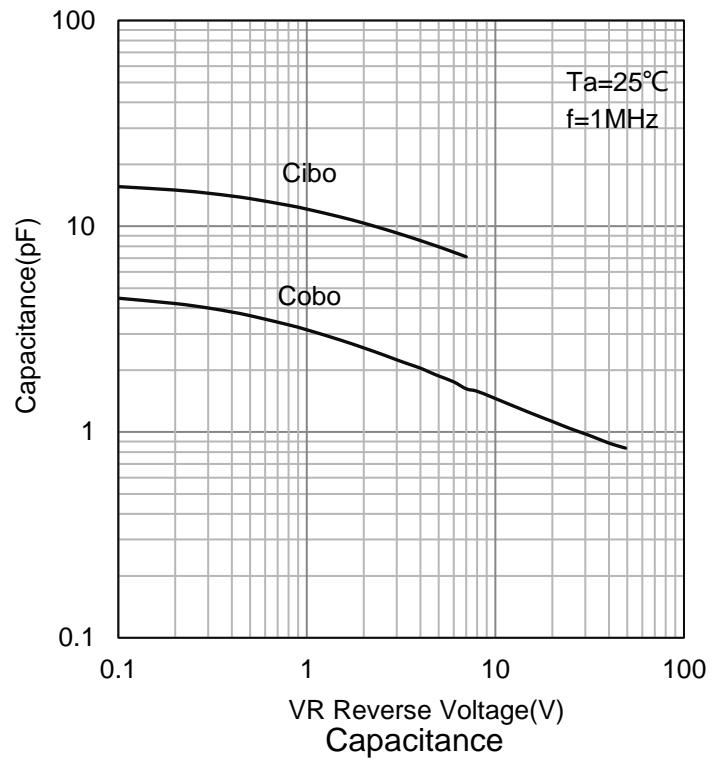
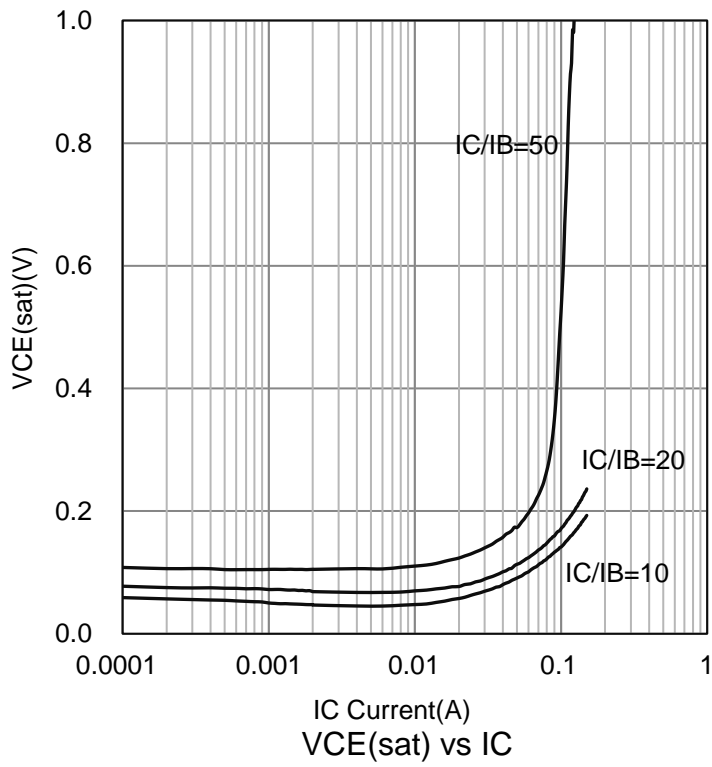

6. OUTLINE AND DIMENSIONS

Notes:

1. DIMENSIONING AND TOLERANCING PER ANSI Y14.5M, 1982.
2. CONTROLLING DIMENSION: MILLIMETERS.
3. MAXIMUM LEAD THICKNESS INCLUDES LEAD FINISH. MINIMUM LEAD THICKNESS IS THE MINIMUM THICKNESS OF BASE MATERIAL.
4. DIMENSIONS D AND E DO NOT INCLUDE MOLD FLASH, PROTRUSIONS OR GATE BURRS.

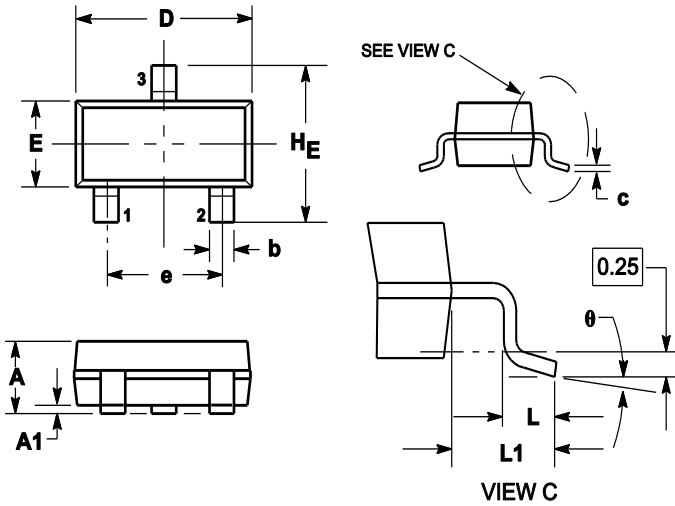

DIM	MILLIMETERS			INCHES		
	MIN	NOM	MAX	MIN	NOM	MAX
A	0.89	1	1.11	0.035	0.04	0.044
A1	0.01	0.06	0.1	0.001	0.002	0.004
b	0.37	0.44	0.5	0.015	0.018	0.02
c	0.09	0.13	0.18	0.003	0.005	0.007
D	2.80	2.9	3.04	0.11	0.114	0.12
E	1.20	1.3	1.4	0.047	0.051	0.055
e	1.78	1.9	2.04	0.07	0.075	0.081
L	0.10	0.2	0.3	0.004	0.008	0.012
L1	0.35	0.54	0.69	0.014	0.021	0.029
HE	2.10	2.4	2.64	0.083	0.094	0.104
θ	0°	---	10°	0°	---	10°

7. SOLDERING FOOTPRINT

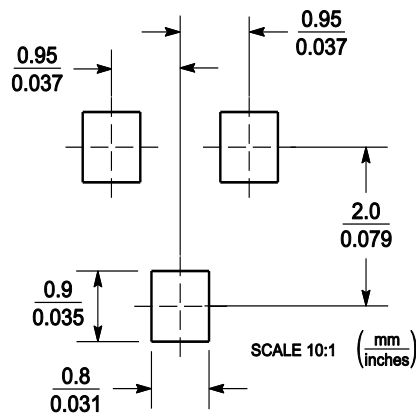

DISCLAIMER

- Curve guarantee in the specification. The curve of test items with electric parameter is used as quality guarantee. The curve of test items without electric parameter is used as reference only.
- Before you use our Products for new Project, you are requested to carefully read this document and fully understand its contents. LRC shall not be in any way responsible or liable for failure, malfunction or accident arising from the use of any LRC's Products against warning, caution or note contained in this document.
- All information contained in this document is current as of the issuing date and subject to change without any prior notice. Before purchasing or using LRC's Products, please confirm the latest information with a LRC sales representative.

单击下面可查看定价，库存，交付和生命周期等信息

[>>LRC\(乐山无线电\)](#)