

**PROGRAMMABLE PRECISION REFERENCE**

# LTL431xxTLT1G

**DESCRIPTION**

The LTL431 is a three-terminal adjustable regulator with a guaranteed thermal stability over applicable temperature ranges. The output voltage may be set to any value between  $V_{ref}$  (approximately 2.5V) and 36V with two external resistors. It provides very wide applications, including shunt regulator, series regulator, switching regulator, voltage reference and others.

**FEATURES**

- Programmable output Voltage to 36V.
- Low dynamic output impedance  $0.2\Omega$
- Sink current capability of 1 to 100mA.
- Equivalent full-range temperature coefficient of 50ppm/ $^{\circ}C$  typical for operation over full rated operating temperature range.

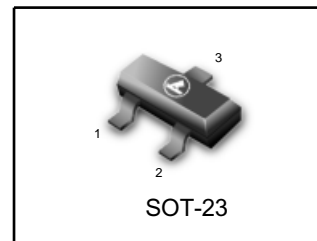

Pin 1: Cathode; 2: Ref; 3: Anode

Pb-Free package is available

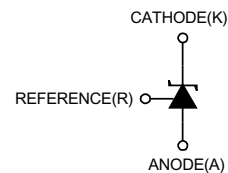
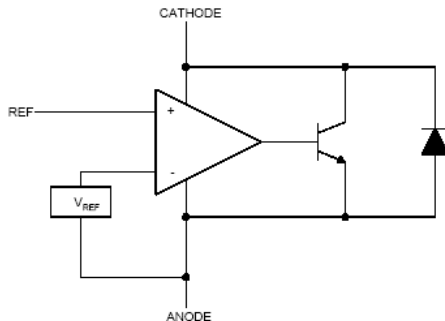
**BLOCK DIAGRAM**

**ABSOLUTE MAXIMUM RATINGS** (Operating temperature range applies unless otherwise specified)

PARAMETER	SYMBOL	VALUE	UNIT
Cathode Voltage	V <sub>K</sub> A	36	V
Cathode Current Range(Continuous)	I <sub>K</sub> A	-100 ~ +150	mA
Reference Input Current Range	I <sub>ref</sub>	-0.05 ~ +10	mA
Operating Junction Temperature	T <sub>j</sub>	150	°C
Operating Ambient Temperature	T <sub>opr</sub>	-40 ~ +125	°C
Storage Temperature	T <sub>stg</sub>	-65 ~ +150	°C

**RECOMMENDED OPERATING CONDITIONS**

PARAMETER	SYMBOL	MIN	TYP	MAX	UNIT
Cathode Voltage	V <sub>K</sub> A	V <sub>REF</sub>		36	V
Cathode Current	I <sub>K</sub> A	1		100	mA

**ELECTRICAL CHARACTERISTICS** (T<sub>a</sub>=25°C, unless otherwise specified)

PARAMETER	SYMBOL	TEST CONDITIONS	MIN	TYP	MAX	UNIT
Reference Input Voltage *	V <sub>ref</sub>	V <sub>K</sub> A=V <sub>REF</sub> , I <sub>K</sub> A=10mA		2.50 2.495		V
Deviation of reference Input Voltage Over temperature(note 1)	ΔV <sub>ref</sub> /ΔT	V <sub>K</sub> A=V <sub>REF</sub> , I <sub>K</sub> A=10mA T <sub>MIN</sub> ≤T <sub>A</sub> ≤T <sub>MAX</sub>		4.5	17	mV
Ratio of Change in Reference Input Voltage to the Change in Cathode Voltage	ΔV <sub>ref</sub> /ΔV <sub>K</sub> A	I <sub>K</sub> A=10mA ΔV <sub>K</sub> A=10V~V <sub>REF</sub> ΔV <sub>K</sub> A=36V~10V		-1.0 -0.5	-2.7 -2.0	mV/V
Reference Input Current	I <sub>ref</sub>	I <sub>K</sub> A=10mA, R1=10kΩ, R2=∞		1.5	4	μA
Deviation of Reference Input Current Over Full Temperature Range	ΔI <sub>ref</sub> /ΔT	I <sub>K</sub> A=10mA, R1=10kΩ, R2=∞ T <sub>A</sub> =full Temperature		0.4	1.2	μA
Minimum Cathode Current for Regulation	I <sub>K</sub> A(min)	V <sub>K</sub> A=V <sub>REF</sub>		0.05	0.1	mA
Off-State Cathode Current	I <sub>K</sub> A(OFF)	V <sub>K</sub> A=36V, V <sub>REF</sub> =0		0.05	1.0	μA
Dynamic Impedance	Z <sub>K</sub> A	V <sub>K</sub> A=V <sub>REF</sub> , I <sub>K</sub> A=1 to 100mA f≤1.0kHz		0.15	0.5	Ω

Note1: T<sub>MIN</sub>= -40 °C, T<sub>MAX</sub>=+125 °C

\*In order to match the special request of customer

**\* CLASSIFICATION OF V<sub>ref</sub> AND PACKAGE**

Type	RanK	Range(V)	Marking	Packa	T <sub>opr</sub>
LTL431ATLT1G	0.5%	2.487~2.512	LA2	SOT-23	-40~+125 °C
LTL431BTLT1G	1%	2.475~2.525	LB2	SOT-23	-40~+125 °C
LTL431APTLT1G	0.5%	2.482~2.507	LA3	SOT-23	-40~+125 °C
LTL431BPTLT1G	1%	2.470~2.520	LB3	SOT-23	-40~+125 °C

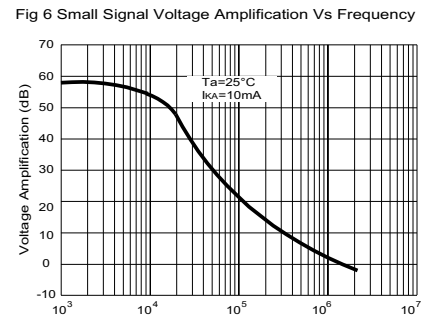
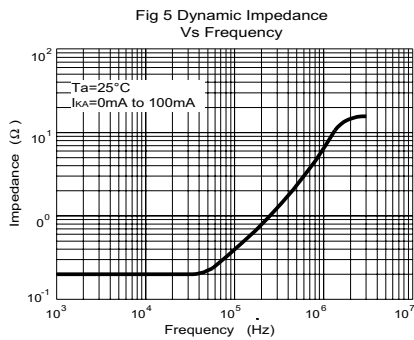
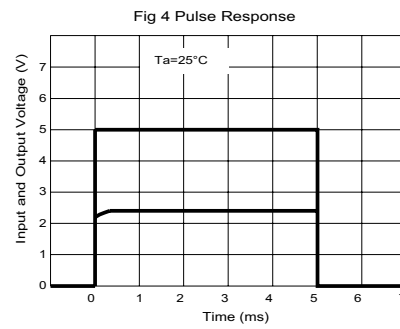
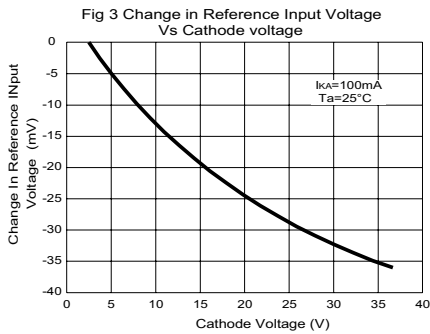
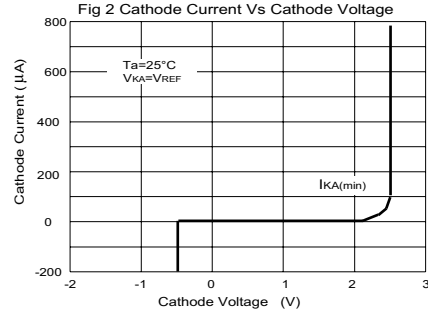
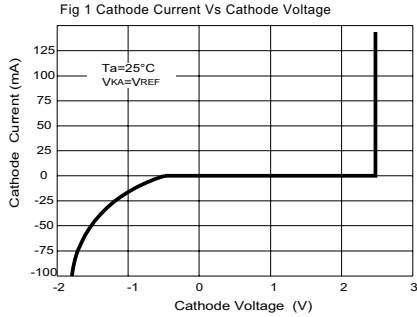
**TYPICAL PERFORMANCE CHARACTERISTICS**

**Fig 7 Stability Boundary Conditions**

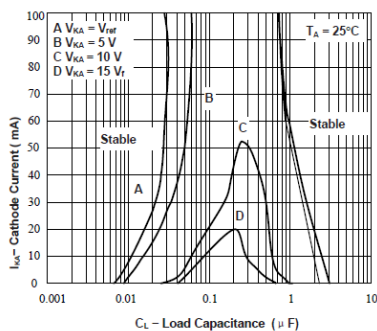

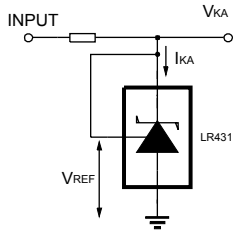
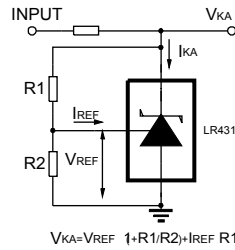
**TEST CIRCUIT**

 Test Circuit For  $V_{KA}=V_{REF}$ 

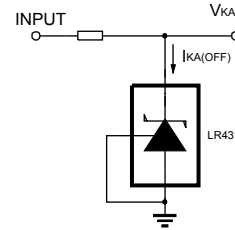
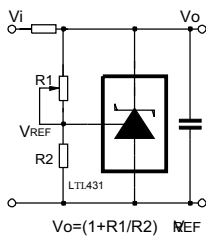
 Test Circuit for  $V_{KA} \geq V_{REF}$ 

$$V_{KA} = V_{REF} (1 + R1/R2) + I_{REF} R1$$

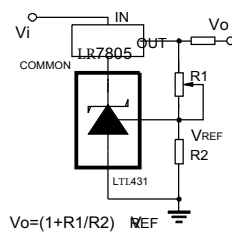

 Test Circuit For  $I_{KA(OFF)}$ 
**APPLICATION CIRCUIT**

Shutdown Regulator

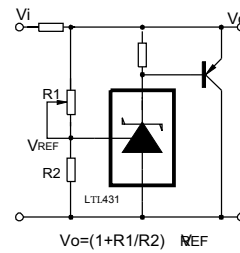

Output Control of a Three-Terminal Fixed Regulator

$$V_o = (1 + R1/R2) V_{REF}$$



Higher-current Shunt Regulator

$$V_o = (1 + R1/R2) V_{REF}$$

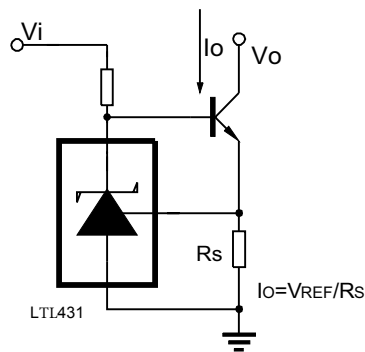

Constant-current Sink

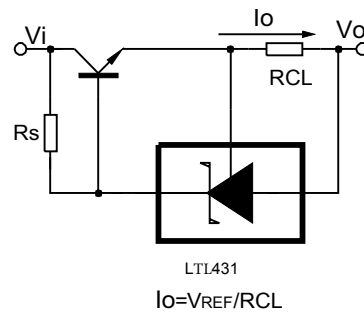

Current Limiting or Current Source

$$I_o = V_{REF}/R_{CL}$$

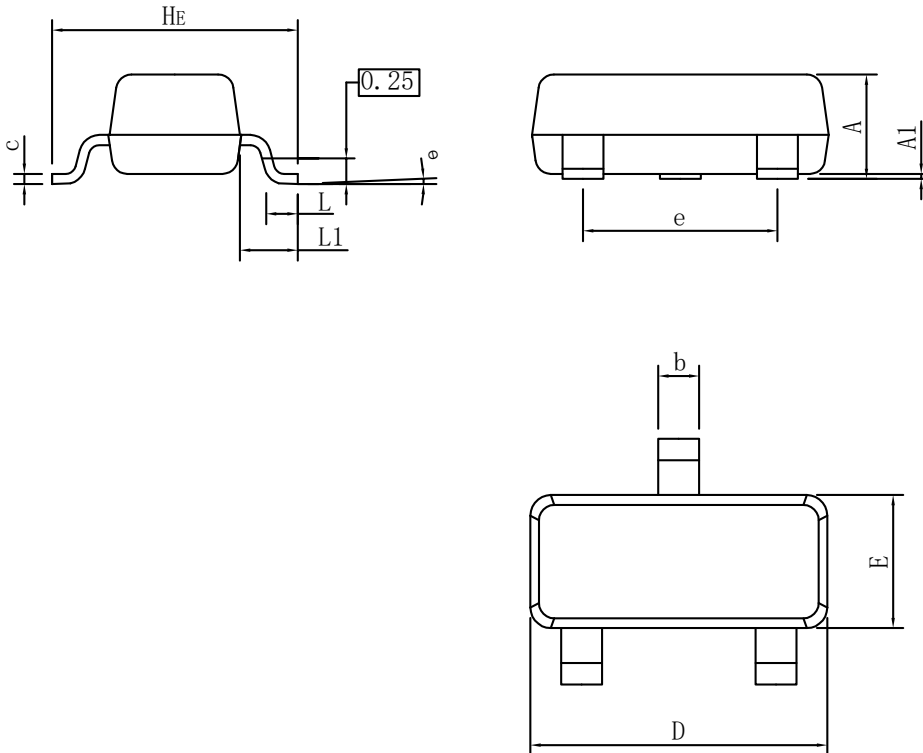
**SOT-23 PACKAGE OUTLINE DIMENSIONS**

SOT23			
DIM	MIN	NOR	MAX
A	0.90	1.00	1.10
A1	0.01	0.06	0.10
b	0.30	0.40	0.50
c	0.10	0.17	0.20
D	2.80	2.90	3.00
E	1.20	1.30	1.40
e	1.80	1.90	2.00
L	0.20	0.40	0.60
L1	0.60REF		
HE	2.20	2.40	2.60
θ	0°	-	10°
All Dimensions in mm			

**GENERAL NOTES**

1. Top package surface finish  $Ra0.4 \pm 0.2\mu m$
2. Bottom package surface finish  $Ra0.7 \pm 0.2\mu m$
3. Side package surface finish  $Ra0.4 \pm 0.2\mu m$

单击下面可查看定价，库存，交付和生命周期等信息

[>>LRC\(乐山无线电\)](#)