

LBTN1150DPTUG

S-LBTN1150DPTUG

150V NPN MEDIUM POWER TRANSISTOR

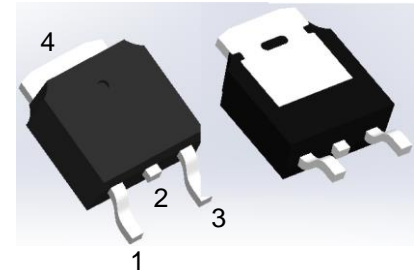

TO-252

1. FEATURES

- $V_{CE0} > 150V$
- $I_C = 1A$ Continuous Collector Current
- $I_{CM} = 2A$ Peak Pulse Current
- We declare that the material of product compliance with RoHS requirements and Halogen Free.
- S- prefix for automotive and other applications requiring unique site and control change requirements; AEC-Q101 qualified and PPAP capable.

2. DEVICE MARKING AND ORDERING INFORMATION

Device	Marking	Shipping
LBTN1150DPTUG	NFP	2500/Tape&Reel

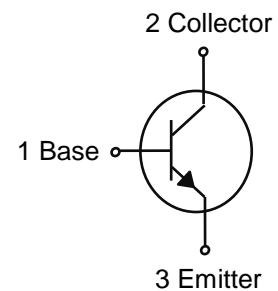

3. MAXIMUM RATINGS($T_a = 25^\circ C$)

Parameter	Symbol	Limits	Unit
Collector–Emitter Voltage	V_{CE0}	150	V
Collector–Base Voltage	V_{CBO}	170	V
Emitter–Base Voltage	V_{EBO}	7	V
Collector Current — Continuous	I_C	1	A
Peak Pulse Current	I_{CM}	2	A
Base Current	I_B	200	mA
Total Power Dissipation (Note 1) @ $T_A = 25^\circ C$	PD	1.75	W
Junction Temperature	T_j	150	$^\circ C$
Storage Temperature Range	T_{stg}	-55~+150	$^\circ C$

4. THERMAL CHARACTERISTICS

Parameter	Symbol	Limits	Unit
Thermal Resistance, Junction–to–Ambient(Note 1)	$R_{\theta JA}$	71.4	$^\circ C/W$

1. These ratings are applicable when surface mounted on the minimum pad sizes recommended.

5. ELECTRICAL CHARACTERISTICS (Ta= 25°C)
OFF CHARACTERISTICS

Characteristic	Symbol	Min.	Typ.	Max.	Unit
Collector–Emitter Breakdown Voltage (IC = 10 mA, IB = 0)	VBR(CEO)	150	-	-	V
Collector–Base Breakdown Voltage (IC = 100 μA, IE = 0)	VBR(CBO)	170	-	-	V
Emitter–Base Breakdown Voltage (IE = 100 μA, IC = 0)	VBR(EBO)	7	-	-	V
Collector Cutoff Current (VCB=150V)	ICBO	-	-	100	nA
Emitter Cutoff Current (VEB = 5V)	IEBO	-	-	100	nA
Collector Emitter Cutoff Current (VCE=150V)	ICES	-	-	100	nA

ON CHARACTERISTICS

Static Forward Current Transfer Ratio (IC = 1mA, VCE = 10V) (IC = 250mA, VCE = 10V) (IC = 500mA, VCE = 10V) (IC = 1A, VCE = 10V)	HFE	100 100 50 10	- - - -	- 300 - -	
Collector–Emitter Saturation Voltage (IC = 250mA, IB = 25mA) (IC = 500mA, IB = 50mA)	VCE(sat)	- -	- -	0.2 0.3	V
Base-Emitter Turn-On Voltage (IC = 500mA, VCE = 10V)	VBE(on)	-	-	1	V
Base–Emitter Saturation Voltage (IC = 500mA, IB = 50mA)	VBE(sat)	-	-	1	V

SMALL–SIGNAL CHARACTERISTICS

Transition Frequency (VCE = 10V, IC = 50mA, f = 100MHz)	fT	100	-	-	MHz
Output Capacitance (VCB = 10V, f = 1MHz)	Cobo	-	-	10	pF

6.ELECTRICAL CHARACTERISTICS CURVES

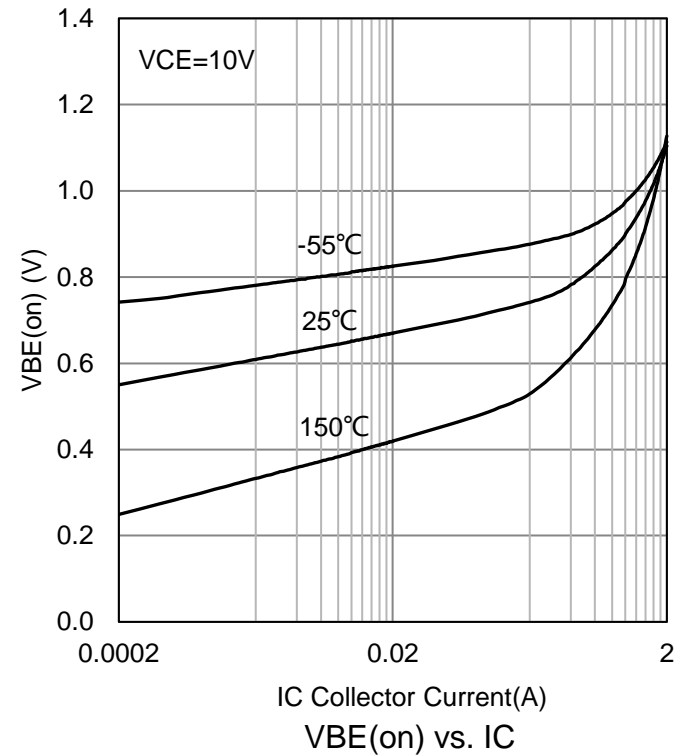
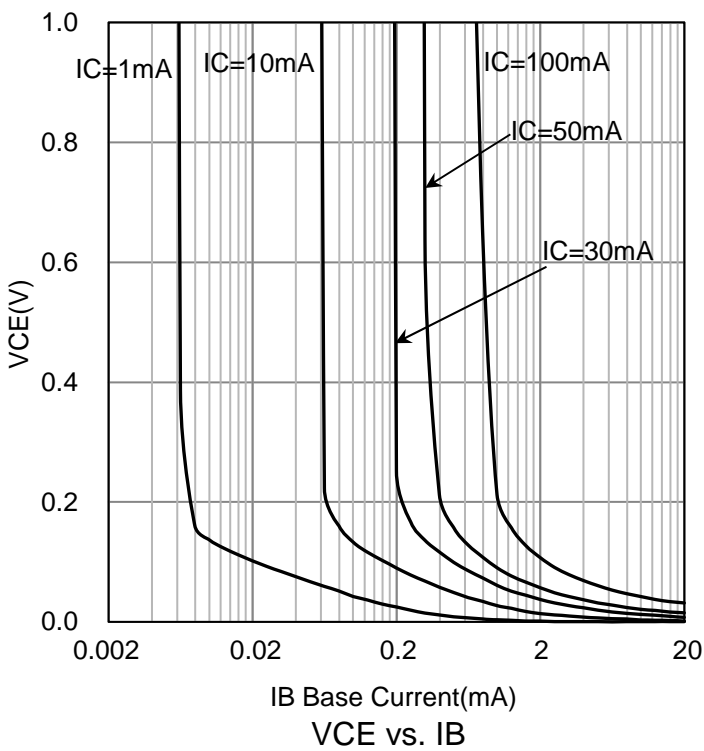
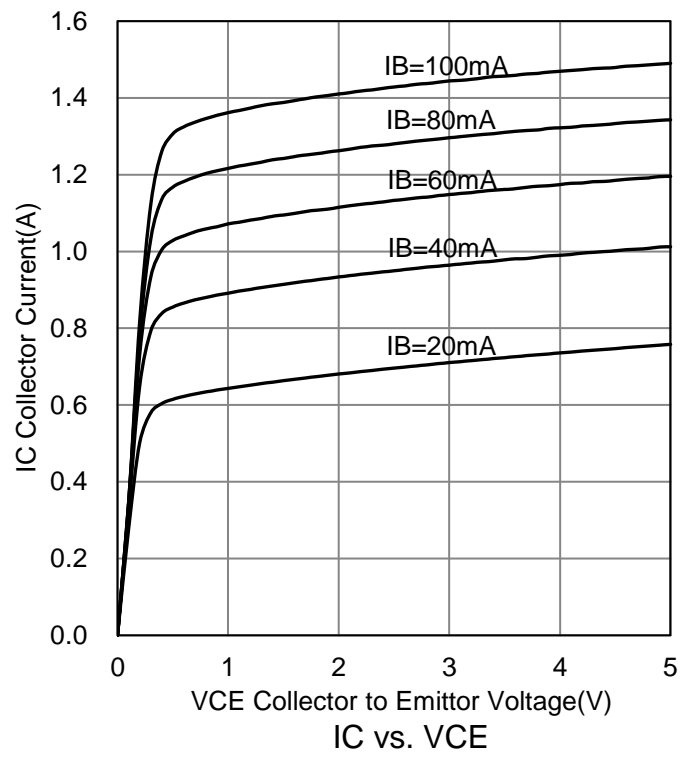
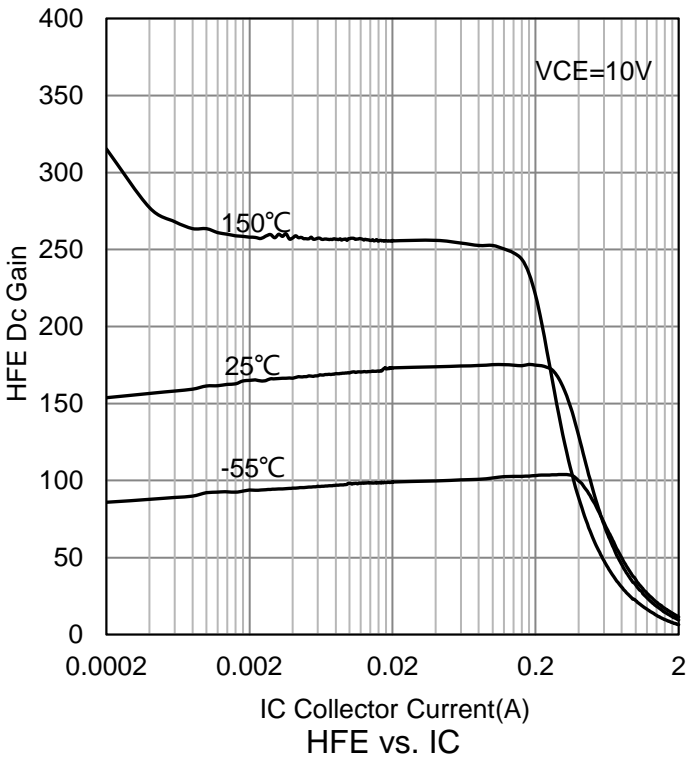

6.ELECTRICAL CHARACTERISTICS CURVES(Con.)

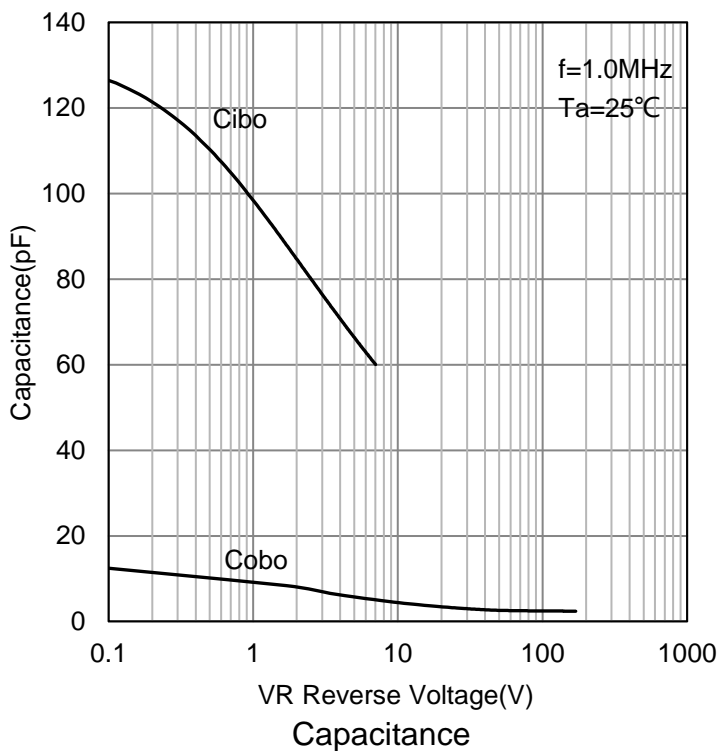
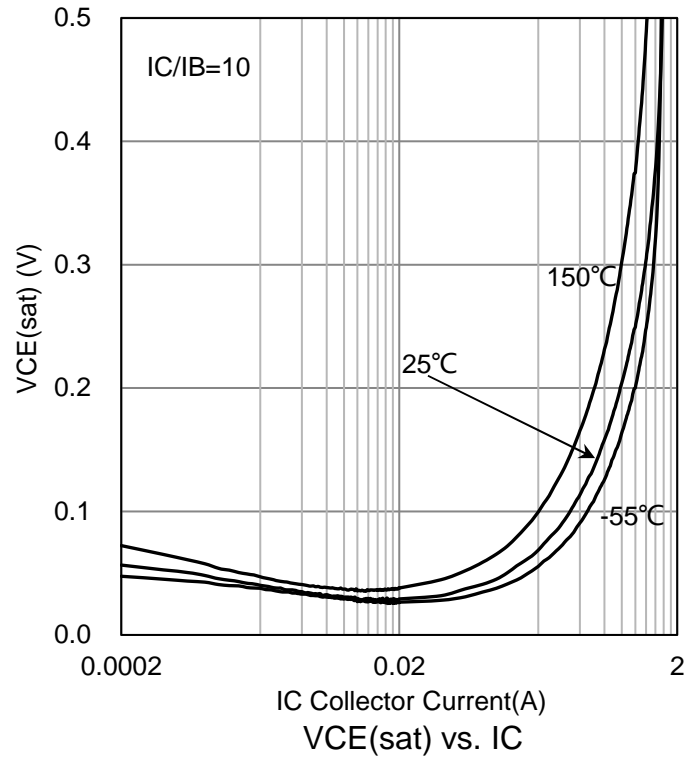
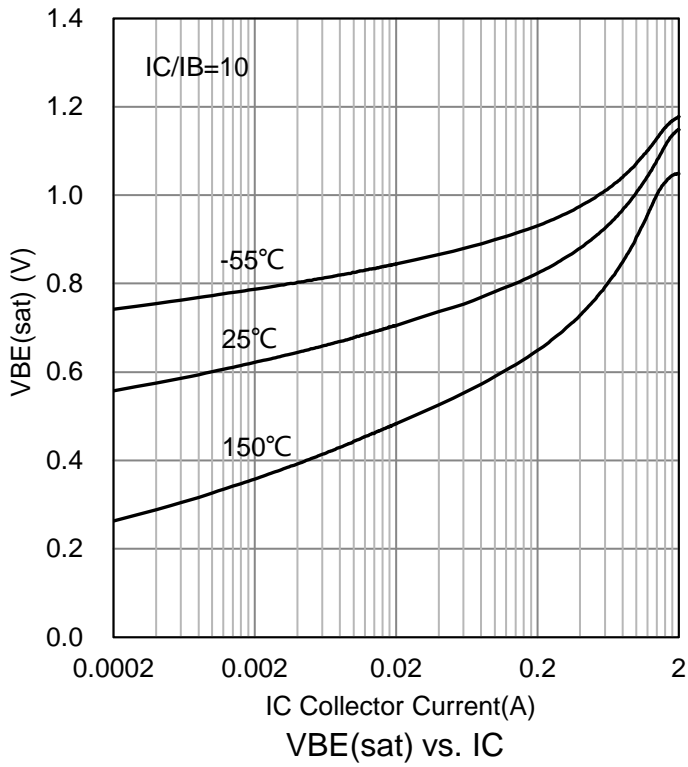

7.OUTLINE AND DIMENSIONS

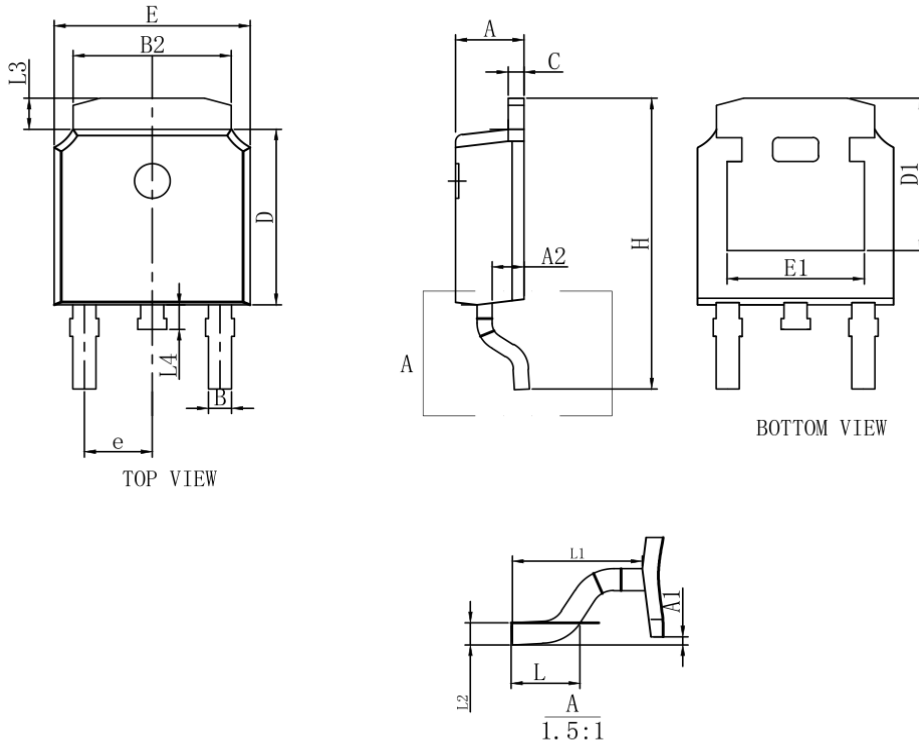

DIM	MILLIMETERS		
	MIN	NOM	MAX
A	2.15	2.30	2.45
A1	-	-	0.20
A2	0.90	1.07	1.17
B	0.68	0.78	0.88
B2	5.20	5.33	5.46
D	5.90	6.10	6.30
D1	5.30REF		
E	6.40	6.60	6.80
E1	4.63	4.83	5.03
e	2.286BSC		
H	9.85	10.10	10.35
L	1.30	1.50	1.70
L1	2.90REF		
L2	0.51BSC		
L3	0.88	1.08	1.28
L4	0.55	0.80	1.05

8.SOLDERING FOOTPRINT

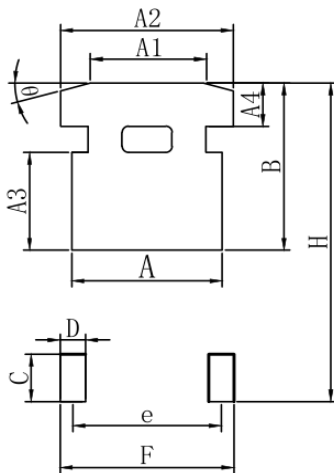

DIM	MIN(mm)
A	6.03
A1	4.50
A2	6.46
A3	4.10
A4	2.37
B	6.50
C	2.50
D	1.68
e	4.80
H	12.35
F	5.95

DISCLAIMER

- Curve guarantee in the specification. The curve of test items with electric parameter is used as quality guarantee. The curve of test items without electric parameter is used as reference only.
- Before you use our Products for new Project, you are requested to carefully read this document and fully understand its contents. LRC shall not be in any way responsible or liable for failure, malfunction or accident arising from the use of any LRC's Products against warning, caution or note contained in this document.
- All information contained in this document is current as of the issuing date and subject to change without any prior notice. Before purchasing or using LRC's Products, please confirm the latest information with a LRC sales representative.

单击下面可查看定价，库存，交付和生命周期等信息

[>>LRC\(乐山无线电\)](#)