

L2SK3541M3T5G

S-L2SK3541M3T5G

Silicon N-Channel MOSFET

1. FEATURES

- Low on-resistance
- Fast switching speed
- Low voltage drive(2.5V) makes this ideal for portable equipment
- Drive circuits can be simple
- Parallel use is easy
- We declare that the material of product compliance with RoHS requirements and Halogen Free.
- S- prefix for automotive and other applications requiring unique site and control change requirements; AEC-Q101 qualified and PPAP capable.

2. APPLICATIONS

- Interfacing,switching(30V,100mA)

3. DEVICE MARKING AND ORDERING INFORMATION

Device	Marking	Shipping
L2SK3541M3T5G	KN	8000/Tape&Reel

4. MAXIMUM RATINGS(Ta = 25°C)

Parameter	Symbol	Limits	Unit
Drain–Source Voltage	VDSS	30	V
Gate–to–Source Voltage	VGS	±20	V
Continuous Drain Current	ID	100	mA
Pulsed Drain Current(Note 1)	IDM	400	mA
Total Power Dissipation(Note 2)	PD	150	mW
Operating Junction and Storage Temperature Range	TJ,Tstg	-55~+150	°C

1.Pulse Test: Pulse Width $\leq 10 \mu\text{s}$, Duty Cycle $\leq 1\%$.

2.With each pin mounted on the recommended lands.

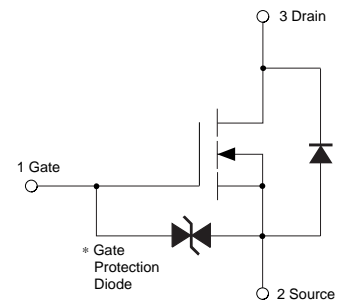
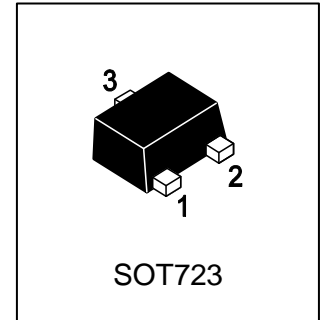

5. ELECTRICAL CHARACTERISTICS (Ta= 25°C)

Characteristic	Symbol	Min.	Typ.	Max.	Unit	
Drain–Source Breakdown Voltage (VGS = 0, ID = 10μA)	V(BR)DSS	30	-	-	V	
Zero Gate Voltage Drain Current (VDS=30V, VGS=0V)	IDSS	-	-	1.0	μA	
Gate-source leakage (VDS = 0 V, VGS = ±20 V)	IGSS	-	-	±1.0	μA	
Gate Threshold Voltage (VDS = 3V, ID = 100μA)	VGS(th)	0.8	-	1.5	V	
Static Drain–Source On–State Resistance (VGS = 4.0 V, ID = 10 mA) (VGS = 2.5 V, ID = 1 mA)	RDS(on)	- -	5 7	8 13	Ω	
Forward transfer admittance (VDS = 3.0 V, ID = 10 mA)	Yfs	20	-	-	mS	
Input Capacitance (VGS = 0 V, f = 1.0MHz, VDS= 5 V)	Ciss	-	13	-	pF	
Output Capacitance (VGS = 0 V, f = 1.0MHz, VDS= 5 V)	Coss	-	9	-	pF	
Reverse Transfer Capacitance (VGS = 0 V, f = 1.0MHz, VDS= 5 V)	Crss	-	4	-	pF	
Turn-On Delay Time	(VGS=5 V, VDD=5 V, ID=10mA, RG=10Ω, RL= 500Ω)	td(on)	-	15	-	ns
Rise Time		tr	-	35	-	
Turn-Off Delay Time		td(off)	-	80	-	
Fall Time		tf	-	80	-	

6.ELECTRICAL CHARACTERISTICS CURVES

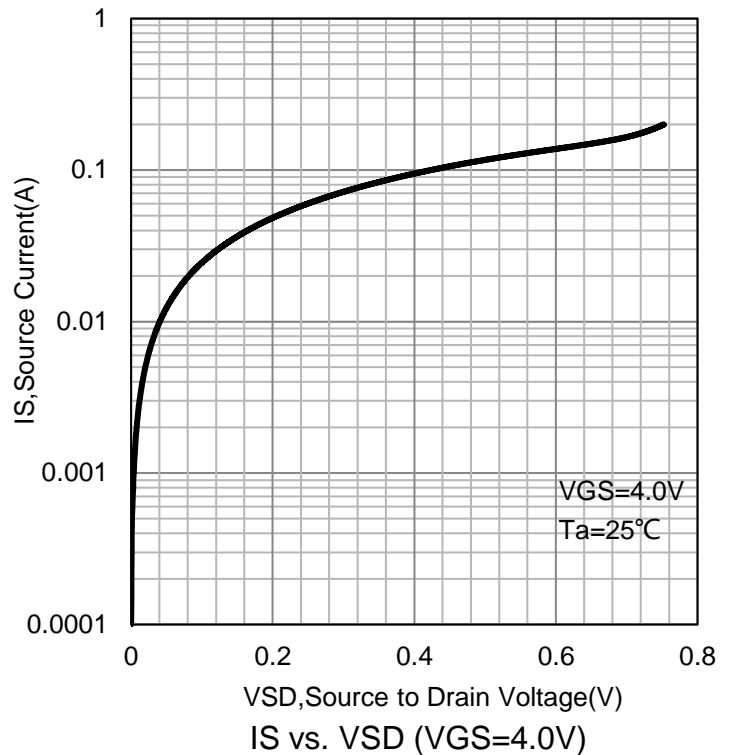
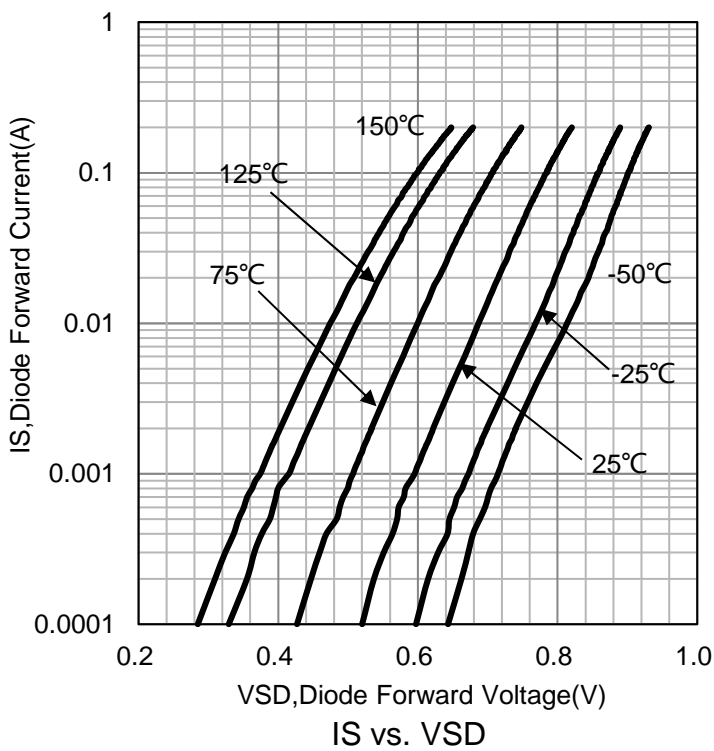
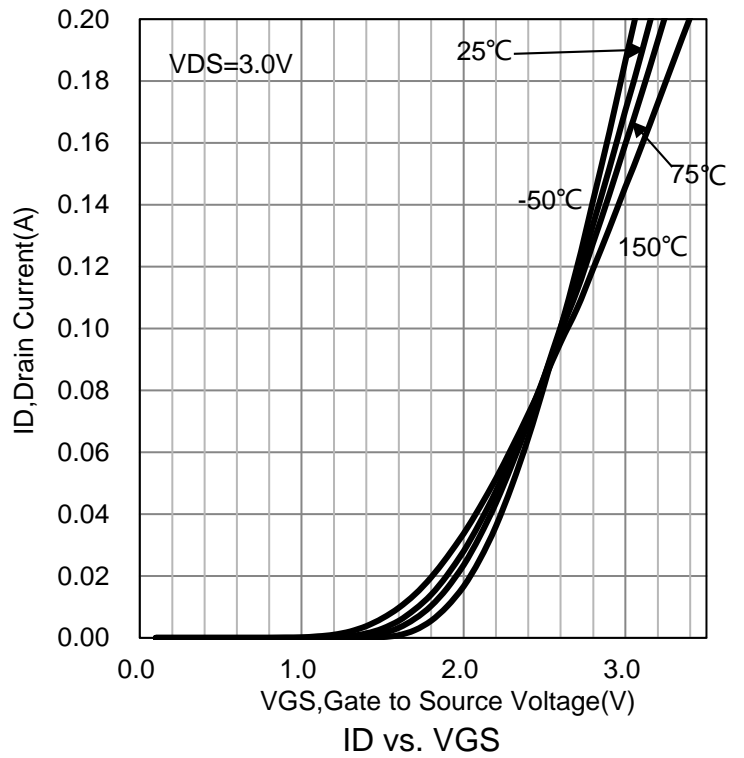
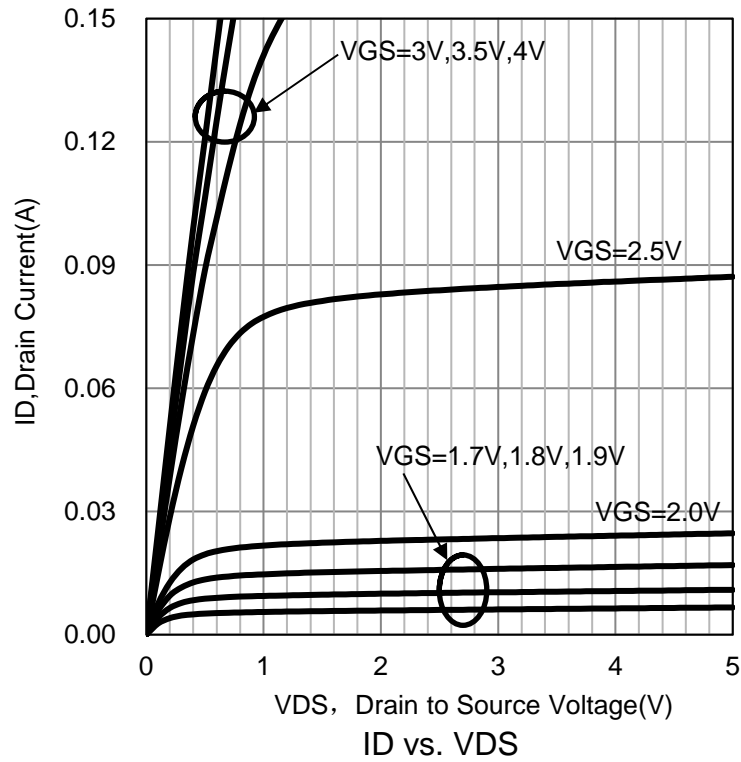

6.ELECTRICAL CHARACTERISTICS CURVES (Con.)

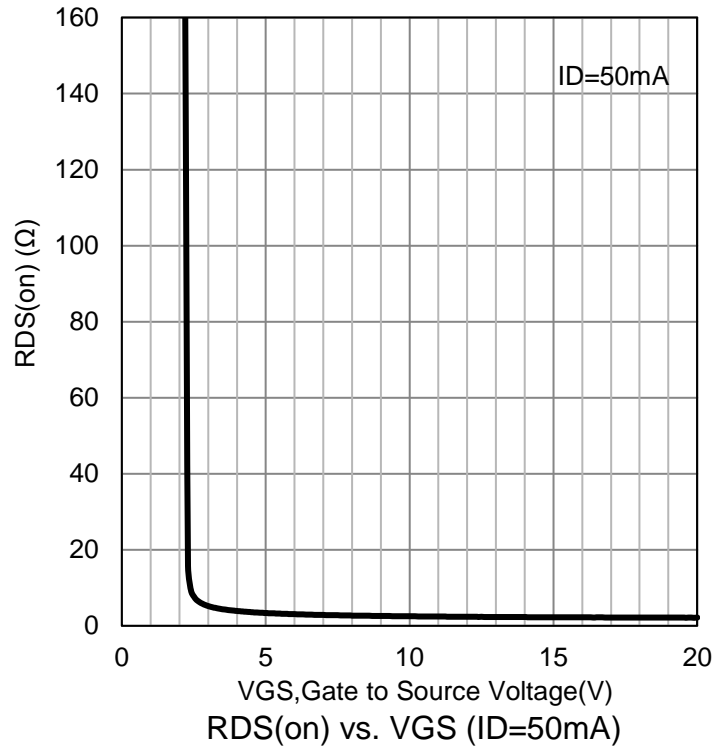
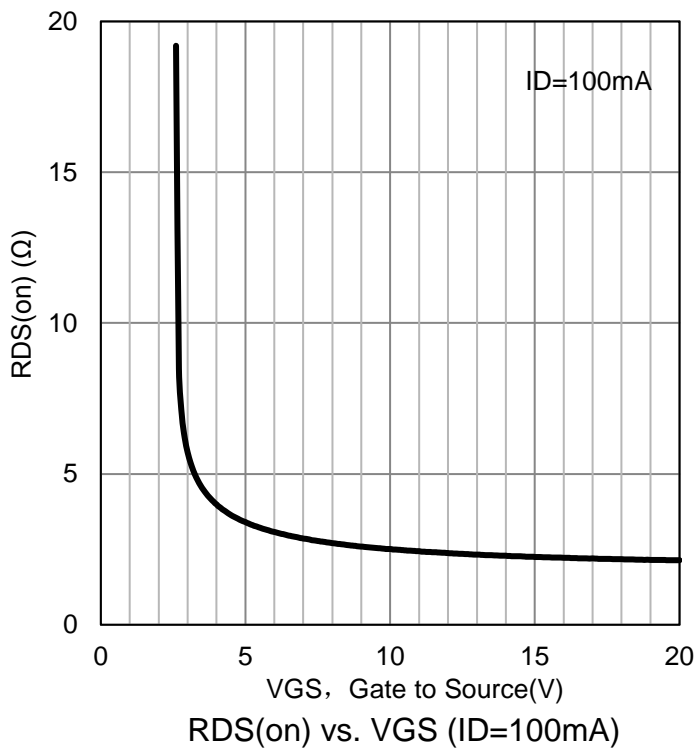
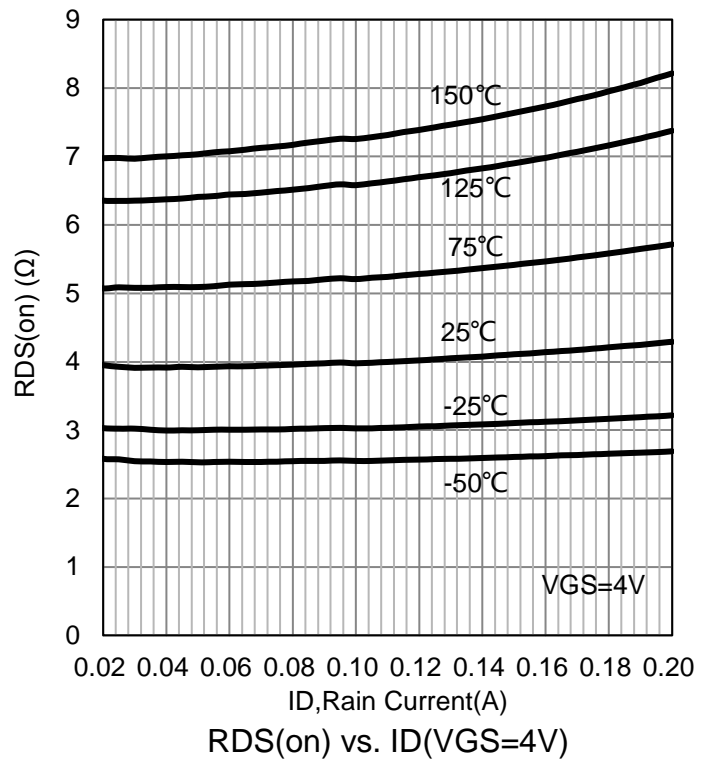
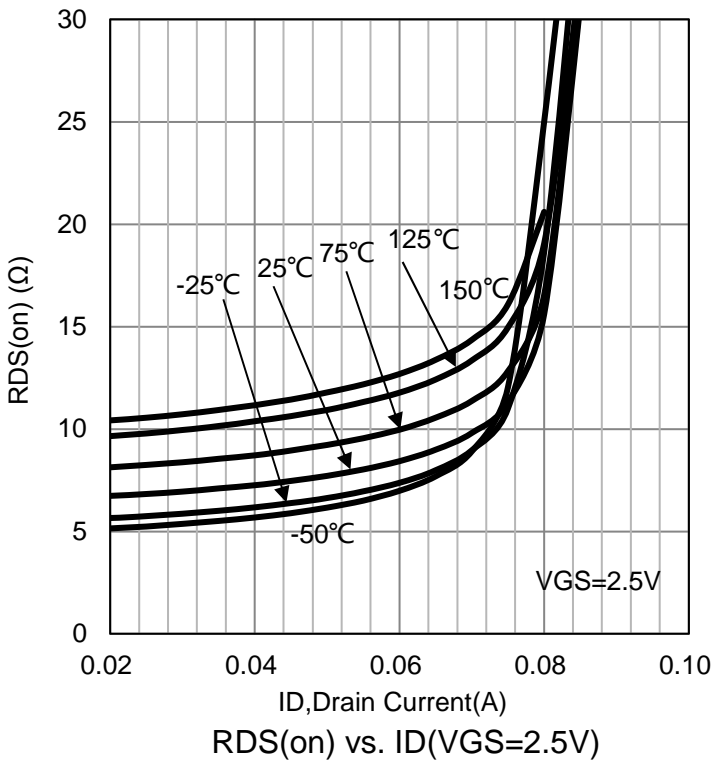

6.ELECTRICAL CHARACTERISTICS CURVES (Con.)

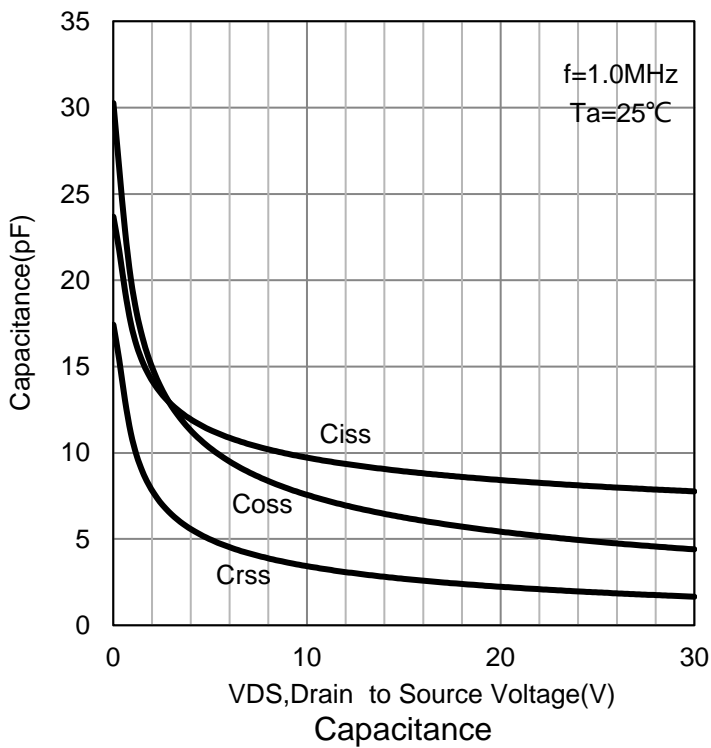
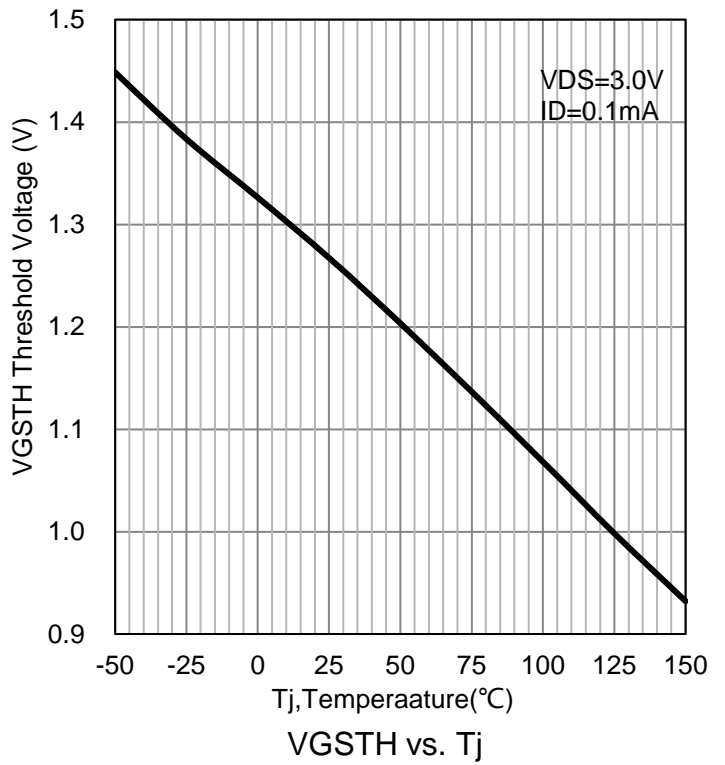
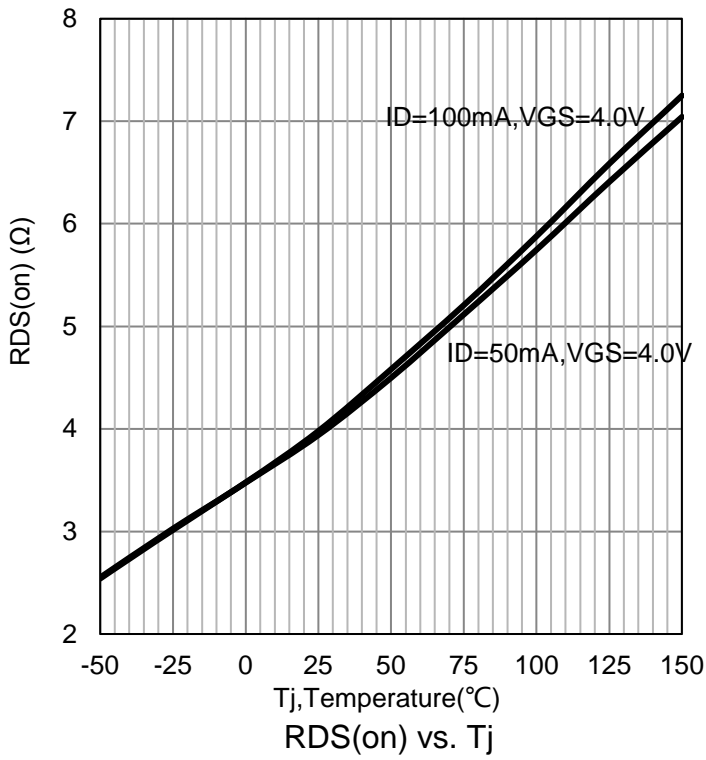

7. OUTLINE AND DIMENSIONS

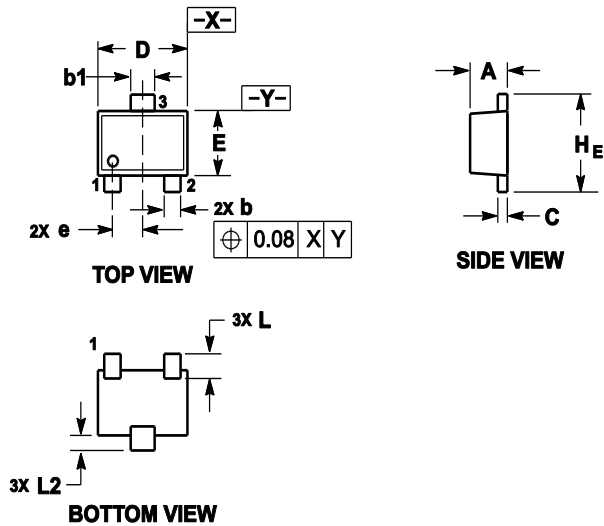

Notes:

1. DIMENSIONING AND TOLERANCING PER ANSI Y14.5M, 1982.
2. CONTROLLING DIMENSION: MILLIMETERS.
3. MAXIMUM LEAD THICKNESS INCLUDES LEAD FINISH. MINIMUM LEAD THICKNESS IS THE MINIMUM THICKNESS OF BASE MATERIAL.
4. DIMENSIONS D AND E DO NOT INCLUDE MOLD FLASH, PROTRUSIONS OR GATE BURRS.

DIM	MILLIMETERS			INCHES		
	MIN	NOM	MAX	MIN	NOM	MAX
A	0.45	0.50	0.55	0.018	0.020	0.039
b	0.15	0.21	0.27	0.006	0.008	0.011
b1	0.25	0.31	0.37	0.010	0.012	0.015
C	0.07	0.12	0.17	0.003	0.005	0.007
D	1.15	1.20	1.25	0.045	0.047	0.049
E	0.75	0.80	0.85	0.030	0.031	0.033
e	0.40REF			0.016REF		
H _E	1.15	1.20	1.25	0.045	0.047	0.049
L	0.29REF			0.011REF		
L ₂	0.15	0.20	0.25	0.006	0.008	0.010

8. SOLDERING FOOTPRINT

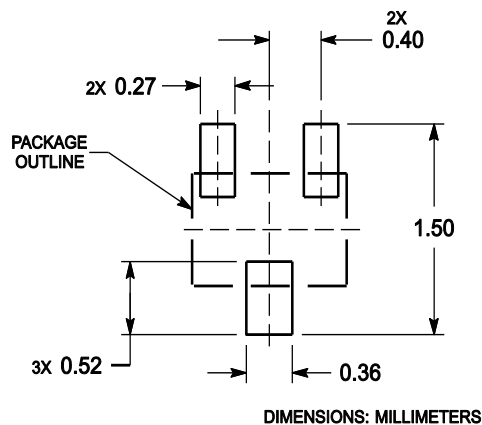

单击下面可查看定价，库存，交付和生命周期等信息

[>>LRC\(乐山无线电\)](#)