

**Ultra Fast High PSRR
Low Noise CMOS Voltage Regulator**

LR6200 Series

■ INTRODUCTION

The LR6200 series are a group of positive voltage regulators manufactured by CMOS technologies with high ripple rejection, ultra low noise, low power consumption and low dropout voltage, which can prolong battery life in portable electronics. The LR6200 series work with low-ESR ceramic capacitors, reducing the amount of board space necessary for power applications. The LR6200 series consume less than 0.1µA in shutdown mode and have fast turn-on time less than 50µS. The series are very suitable for the battery-powered equipments, such as RF applications and other systems requiring a quiet voltage source.

■ APPLICATIONS

- Cellular and Smart Phones
- Laptop, Palmtops and PDA
- Digital Still and Video Cameras

■ BLOCK DIAGRAM

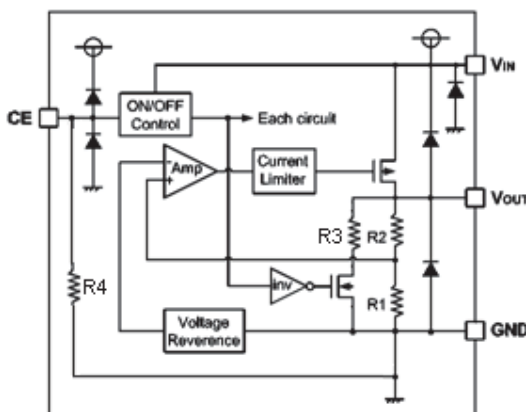

■ FEATURES

- Low Output Noise: 40µV_{RMS} (10Hz~100kHz)
- Low Dropout Voltage: 150mV@150mA
- Low Quiescent Current: 50µA
- High Ripple Rejection: 80dB@217Hz
- Excellent Line and Load Transient Response
- Operating Voltage Range: 2.0V~6.0V
- Output Voltage Range: 1.0V ~ 5.0V
- High Accuracy: ±2% (Typ.)
- Built-in Current Limiter, Short-Circuit Protection
- TTL- Logic-Controlled Shutdown Input
- MP3, MP4 Player
- Radio control systems
- Battery-Powered Equipmen

■ ORDER INFORMATION

LR6200①②③④

DESIGNATOR	SYMBOL	DESCRIPTION
①	A	Standard
	B	High Active, pull-down resistor R4 built in, with C _{OUT} discharge resistor
	C	High Active, No pull-down resistor , No C _{OUT} discharge resistor
②③	10~50	Output Voltage e.g.②:1, ③:8= 1.8V
④	M/MA/MC/MY	Package:SOT-23-3
	M/MF/ML	Package:SOT-23-5
	P/PT	Package:SOT-89-3
	F	Package:DFN1×1-4

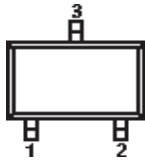
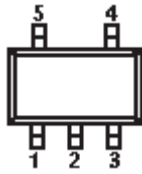
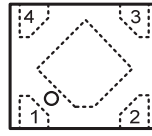
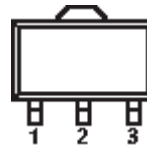
■ PIN CONFIGURATION
SOT-23-3

SOT-23-5

DFN1×1-4

SOT-89-3

SOT-23-3

PIN NUMBER				PIN NAME	FUNCTION
M	MA	MC	MY		
1	2	3	3	V_{SS}	Ground
2	1	2	1	V_{OUT}	Output
3	3	1	2	V_{IN}	Power Input Pin

SOT-23-5

PIN NUMBER			SYMBOL	FUNCTION
M	MF	ML		
1	1	5	V_{IN}	Power Input Pin
2	2	2	V_{SS}	Ground
3	—	1	CE	Chip Enable Pin
4	3/4	3	NC	No Connection
5	5	4	V_{OUT}	Output Pin

DFN1×1-4

PIN NUMBER		SYMBOL	FUNCTION
F			
1		V_{OUT}	Output Pin
2		V_{SS}	Ground
3		CE	Chip Enable Pin
4		V_{IN}	Power Input Pin

SOT-89-3

PIN NUMBER		PIN NAME	FUNCTION
P	PT		
1	2	V_{SS}	Ground
3	1	V_{OUT}	Output
2	3	V_{IN}	Power Input Pin

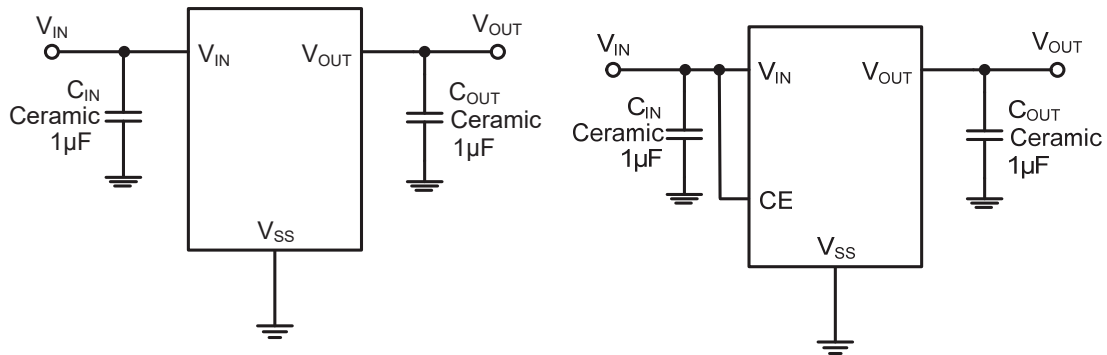
■ TYPICAL APPLICATION

■ ABSOLUTE MAXIMUM RATINGS⁽¹⁾

 (Unless otherwise specified, $T_A=25^{\circ}\text{C}$)

PARAMETER		SYMBOL	RATINGS	UNITS
Input Voltage ⁽²⁾		V_{IN}	-0.3~ 7	V
Output Voltage ⁽²⁾		V_{OUT}	-0.3~ $V_{IN}+0.3$	V
Output Current		I_{OUT}	600	mA
Power Dissipation	SOT-23-3 SOT-23-5	P_D	0.4	W
	SOT-353(SC70-5)		0.4	W
	DFN1X1-4		0.4	W
	SOT-89-3SOT-89-5		0.6	W
Operating free air temperature range		T_A	-40~85	$^{\circ}\text{C}$
Operating Junction Temperature Range ⁽³⁾		T_j	-40~125	$^{\circ}\text{C}$
Storage Temperature		T_{stg}	-40~125	$^{\circ}\text{C}$
Lead Temperature(Soldering, 10 sec)		T_{solder}	260	$^{\circ}\text{C}$
ESD rating ⁽⁴⁾	Human Body Model -(HBM)		2	kV
	Machine Model- (MM)		200	V

(1) Stresses beyond those listed under *absolute maximum ratings* may cause permanent damage to the device. These are stress ratings only, and functional operation of the device at these or any other conditions beyond those indicated under *recommended operating conditions* is not implied. Exposure to absolute-maximum-rated conditions for extended periods may affect device reliability.

(2) All voltages are with respect to network ground terminal.

(3) This IC includes over temperature protection that is intended to protect the device during momentary overload. Junction temperature will exceed 125°C when over temperature protection is active. Continuous operation above the specified maximum operating junction temperature may impair device reliability.

(4) ESD testing is performed according to the respective JESD22 JEDEC standard.

The human body model is a 100 pF capacitor discharged through a 1.5k Ω resistor into each pin. The machine model is a 200pF capacitor discharged directly into each pin.

■ RECOMMENDED OPERATING CONDITIONS

PARAMETER	MIN.	NOM.	MAX.	UNITS
Supply voltage at V_{IN}	2		6	V
Operating junction temperature range, T_j	0		125	$^{\circ}\text{C}$
Operating free air temperature range, T_A	0		85	$^{\circ}\text{C}$

■ POWER DISSIPATION RATING TABLE

PACKAGE ⁽⁵⁾	$R_{\theta JA}$	$T_A \leq 25^{\circ}\text{C}$ POWER RATING	$T_A = +70^{\circ}\text{C}$ POWER RATING	$T_A = +85^{\circ}\text{C}$ POWER RATING
SOT23	229.8 $^{\circ}\text{C}/\text{W}$	435 mW	239 mW	174 mW
SOT89	152.2 $^{\circ}\text{C}/\text{W}$	657 mW	361 mW	262 mW

(5) JESD24-3, 24-4, 24-6 Thermal Impedance Measurements

■ ELECTRICAL CHARACTERISTICS

LR6200 Series ($V_{IN}=V_{OUT}+1V$, $C_{IN}=C_{OUT}=1\mu F$, $T_A=25^\circ C$, unless otherwise specified)

PARAMETER	SYMBOL	CONDITIONS	MIN.	TYP. ⁽⁶⁾	MAX.	UNITS
Output Voltage	$V_{OUT(E)}$ ⁽⁷⁾	$I_{OUT}=1mA$	$V_{OUT}^{(8)}$ *0.98	$V_{OUT}^{(8)}$	$V_{OUT}^{(8)}$ *1.02	V
Supply Current	I_{SS}	$I_{OUT}=0$		50	100	μA
Standby Current	I_{STBY}	$CE = V_{SS}$			0.1	μA
Output Current	I_{OUT}	—	300			mA
Dropout Voltage	$V_{DO}^{(9)}$	$I_{OUT} = 150mA$ $V_{OUT} \geq 2.8V$		150		mV
Load Regulation	ΔV_{OUT}	$V_{IN} = V_{OUT} + 1V$, $1mA \leq I_{OUT} \leq 100mA$		10		mV
Line Regulation	$\frac{\Delta V_{OUT}}{V_{OUT} \times \Delta V_{IN}}$	$I_{OUT} = 10mA$ $V_{OUT} + 1V \leq V_{IN} \leq 6V$		0.01	0.2	%/V
Output Voltage Temperature Characteristics	$\frac{\Delta V_{OUT}}{\Delta T \times V_{OUT}}$	$I_{OUT} = 10mA$ $-40 \leq T \leq +85$		100		ppm
Short Current	I_{Short}	$V_{OUT} = V_{SS}$		100		mA
Input Voltage	V_{IN}	—	2.0		6.0	V
Power Supply Rejection Rate	217Hz	PSRR	$I_{OUT}=50mA$		80	dB
	1kHz				75	
	10kHz				70	
CE "High" Voltage	$V_{CE} "H"$		1.5		V_{IN}	V
CE "Low" Voltage	$V_{CE} "L"$				0.3	V
C_{OUT} Auto-Discharge Resistance	$R_{DISCHRG}$	$V_{IN}=5V$, $V_{OUT}=3.0V$, $V_{CE}=V_{SS}$		80		Ω

(6) Typical numbers are at 25°C and represent the most likely norm.

(7) $V_{OUT(E)}$: Effective Output Voltage (i.e. The output voltage when $V_{IN} = (V_{OUT} + 1.0V)$ and maintain a certain I_{OUT} Value).

(8) V_{OUT} : Specified Output Voltage.

(9) V_{DO} : The Difference Of Output Voltage And Input Voltage When Input Voltage Is Decreased Gradually Till Output Voltage Equals To 98% Of V_{OUT} (E).

■ DROPOUT VOLTAGE CHART

Setting Output Voltage	Dropout Voltage(mV)@ $I_{OUT}=150mA$	
$V_{OUT}(V)$	Typ.	Max.
1.2	380	600
1.5	270	600
1.8	230	600
2.5	180	400
2.8	160	220
3.0	155	220
3.3	150	220

■ TYPICAL PERFORMANCE CHARACTERISTICS

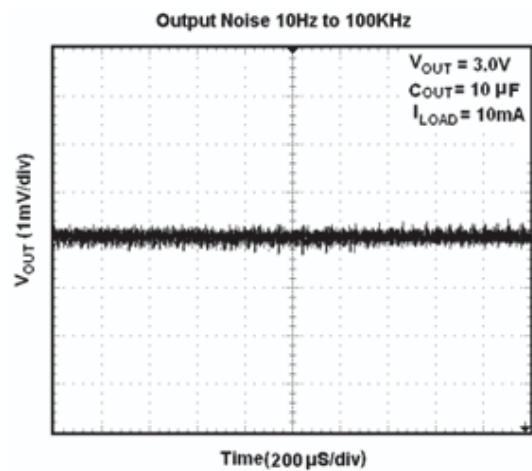
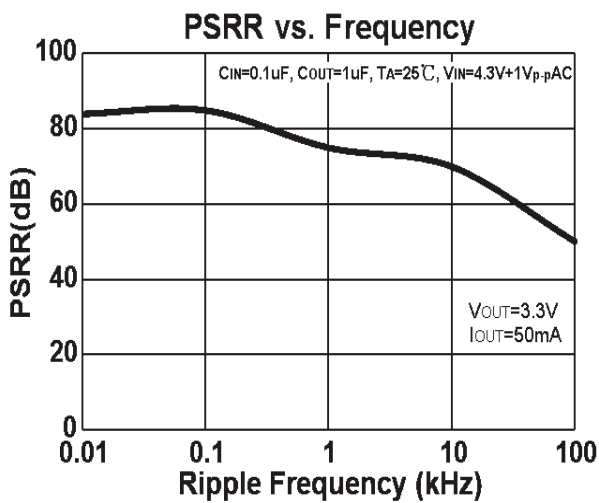
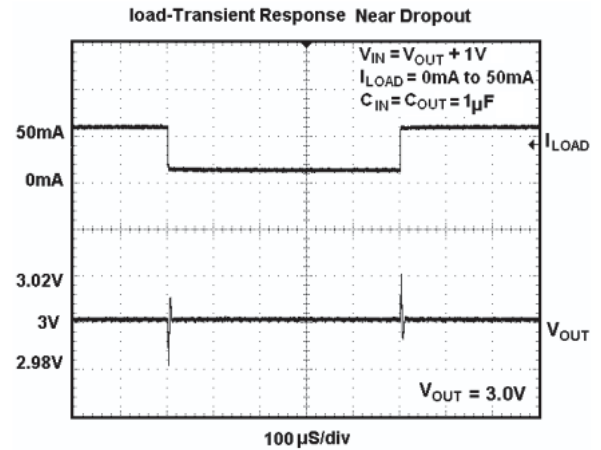
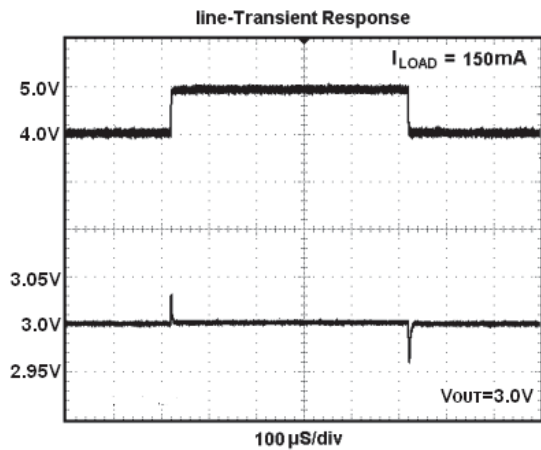
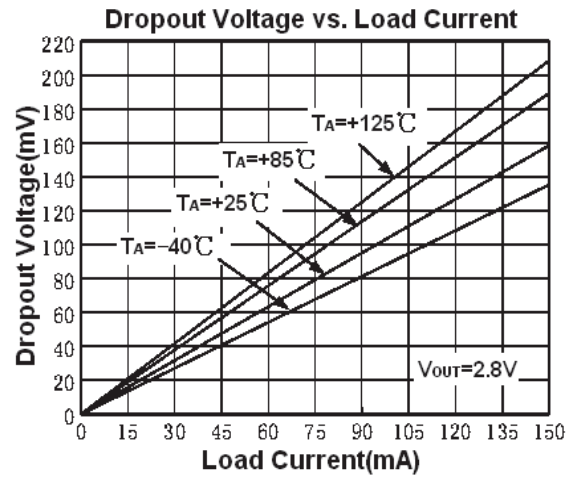
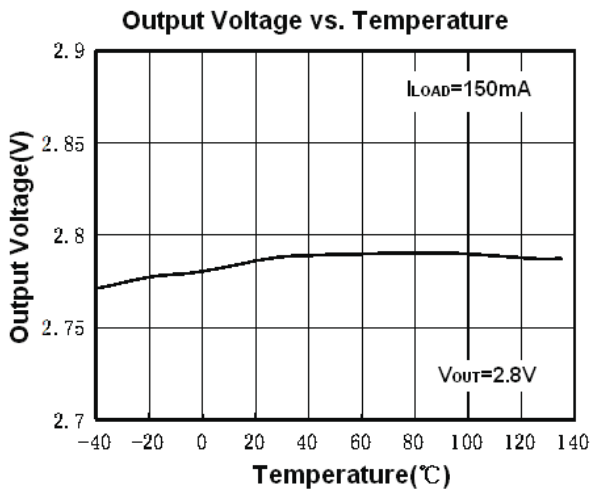

■ TYPICAL PERFORMANCE CHARACTERISTICS

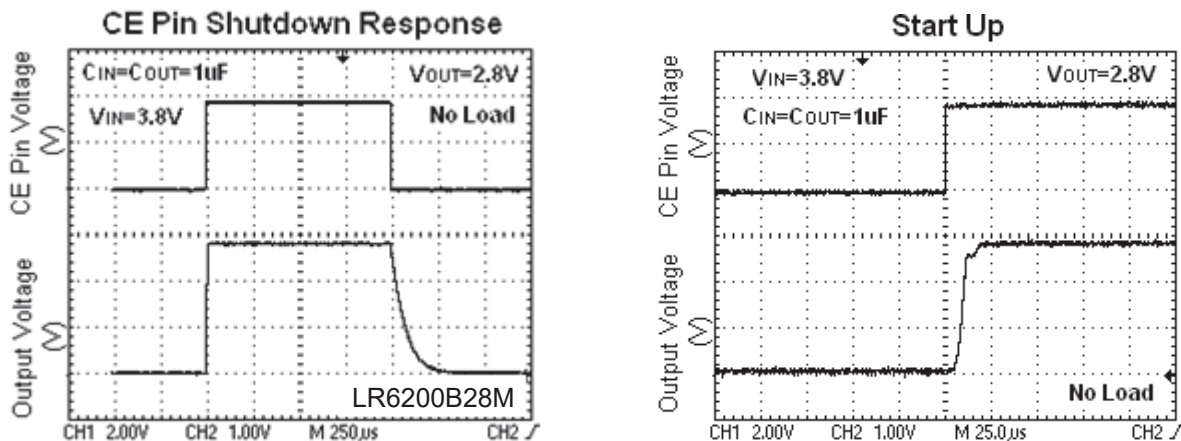

C_{OUT} Auto-Discharge Function

LR6200B series can discharge the electric charge in the output capacitor (C_{OUT}), when a low signal to the CE pin, which enables a whole IC circuit turn off, is inputted via the N-channel transistor located between the V_{OUT} pin and the V_{SS} pin (cf. BLOCK DIAGRAM). The C_{OUT} auto-discharge resistance value is set at 80Ω (V_{OUT}=3.0V @ V_{IN}=5.0V at typical). The discharge time of the output capacitor (C_{OUT}) is set by the C_{OUT} auto-discharge resistance (R) and the output capacitor (C_{OUT}). By setting time constant of a C_{OUT} auto-discharge resistance value [R_{DISCHRG}] and an output capacitor value (C_{OUT}) as τ (τ=C_{OUT} × R_{DISCHRG}), the output voltage after discharge via the N-channel transistor is calculated by the following formulas.

$$V = V_{OUT(E)} \times e^{-t/\tau}, \text{ or } t = \tau \ln (V / V_{OUT(E)})$$

(V : Output voltage after discharge, V_{OUT(E)} : Output voltage, t: Discharge time,

τ: C_{OUT} auto-discharge resistance R_{DISCHRG}×Output capacitor (C_{OUT}) value C)

■ PACKAGING INFORMATION

● SOT-23-3 PACKAGE OUTLINE DIMENSIONS

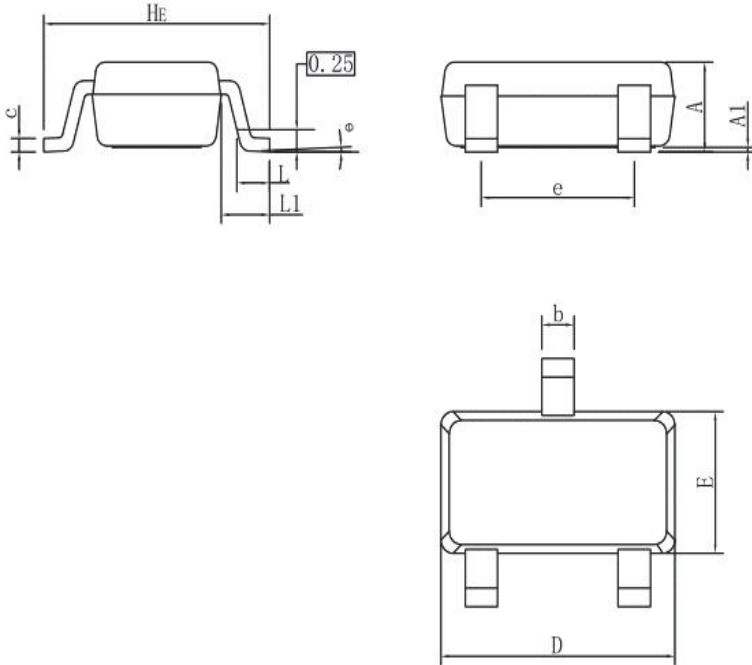

DIM	MIN	NOR	MAX
A	0.90	1.00	1.10
A1	0.01	0.06	0.10
b	0.30	0.40	0.50
c	0.10	0.17	0.20
D	2.80	2.90	3.00
E	1.50	1.60	1.70
e	1.80	1.90	2.00
L	0.20	0.40	0.60
L1	0.60REF		
HE	2.60	2.80	3.00
θ	0°	-	10°
All Dimensions in mm			

GENERAL NOTES

- 1.Top package surface finish Ra0.4±0.2um
- 2.Bottom package surface finish Ra0.7±0.2um
- 3.Side package surface finish Ra0.4±0.2um

SOLDERING FOOTPRINT

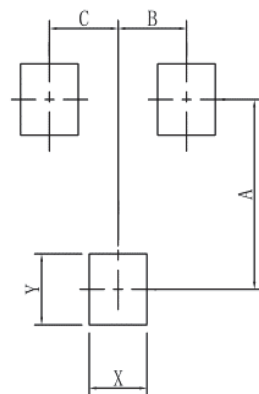

DIM	(mm)
X	0.80
Y	0.90
A	2.40
B	0.95
C	0.95

• SOT-23-5 PACKAGE OUTLINE DIMENSIONS

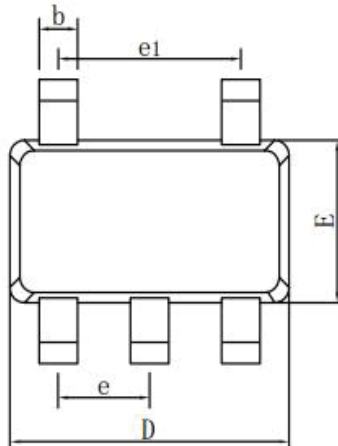
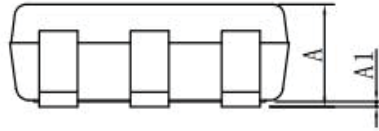
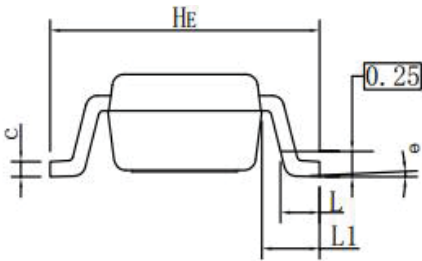

DIM	MIN	NOR	MAX
A	0.90	1.00	1.10
A1	0.01	0.06	0.10
b	0.30	0.40	0.50
c	0.10	0.17	0.20
D	2.80	2.90	3.00
E	1.50	1.60	1.70
e	0.85	0.95	1.05
ei	1.80	1.90	2.00
L	0.20	0.40	0.60
L1	0.60REF		
He	2.60	2.80	3.00
θ	0°	-	10°

SOLDERING FOOTPRINT

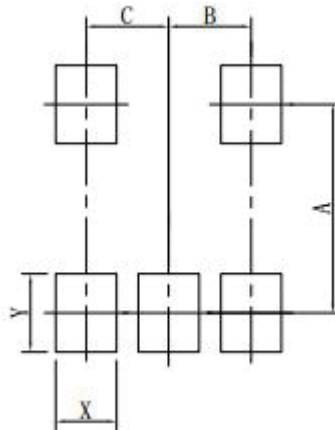

DIM	(mm)
X	0.70
Y	0.90
A	2.40
B	0.95
C	0.95

● DFN1×1-4 PACKAGE OUTLINE DIMENSIONS

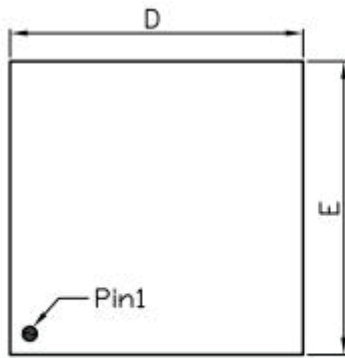

TOP VIEW

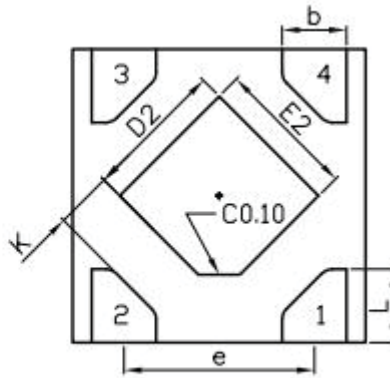

BOTTOM VIEW

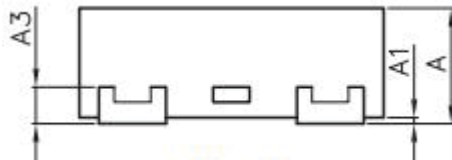

SIDE VIEW

DFN1010			
DIM	MIN	NOR	MAX
A	0.34	0.37	0.40
A1	0.01	0.02	0.05
b	0.17	0.22	0.25
L	0.20	0.25	0.30
D	0.95	1.00	1.05
E	0.95	1.00	1.05
D2	0.43	0.48	0.53
E2	0.43	0.48	0.53
e	0.65		
A3	0.127REF.		
K	0.15	-	-
All Dimensions in mm			

SOLDERING FOOTPRINT

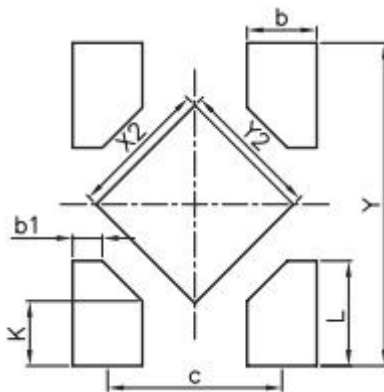

DFN1010	
DIM	(mm)
X2	0.52
Y2	0.52
L	0.39
Y	1.20
K	0.24
b	0.26
c	0.65
b1	0.11

● SOT-89-3 PACKAGE OUTLINE DIMENSIONS

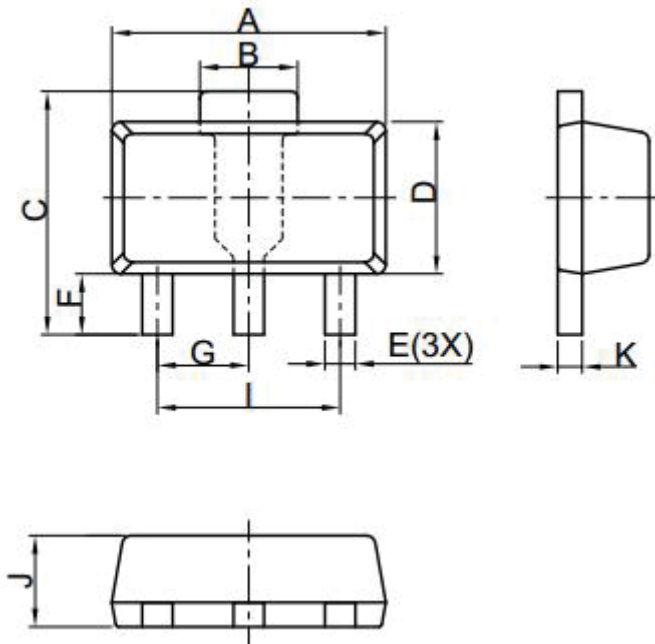

DIM	MIN	NOR	MAX
A	4.40	4.50	4.60
B	1.40	1.60	1.80
C	3.90	4.00	4.25
D		2.50	2.60
E		0.50	0.58
F	0.90	1.00	1.20
G	1.50 BSC		
I	3.00 BSC		
J	1.40	1.50	1.60
K	0.34	0.40	0.50
All Dimensions in mm			

GENERAL NOTES

1. Top package surface finish Ra0.4±0.2um
2. Bottom package surface finish Ra0.7±0.2um
3. Side package surface finish Ra0.4±0.2um
4. Protrusion or Gate Burrs shall not exceed 0.10mm per side.

SOLDERING FOOTPRINT

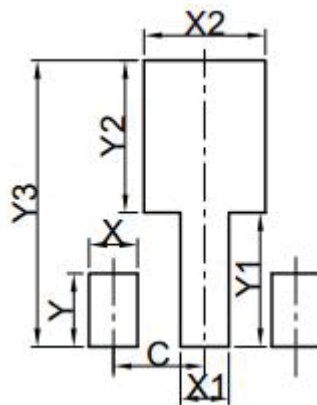

DIM	(mm)
X	0.80
Y	1.20
X1	0.80
Y1	2.20
X2	2.00
Y2	2.50
C	1.50
Y3	4.70

■ ORDER INFORMATION APPENDIX

Device ⁽¹⁰⁾	Output Voltage ⁽¹¹⁾	Package	Marking ⁽¹²⁾⁽¹³⁾	Shipping
LR6200AxxM	1.0V~5.0V	SOT-23-3	2AX	3K/Reel
LR6200AxxMA	1.0V~5.0V	SOT-23-3	2AX	3K/Reel
LR6200AxxMC	1.0V~5.0V	SOT-23-3	2AX	3K/Reel
LR6200AxxMY	1.0V~5.0V	SOT-23-3	2AX	3K/Reel
LR6200BxxM	1.0V~5.0V(Exclude2.5V)	SOT-23-5	2AX	3K/Reel
LR6200B25M	2.5V	SOT-23-5	2YH	3K/Reel
LR6200BxxML	1.0V~5.0V	SOT-23-5	2LX	3K/Reel
LR6200AxxMF	1.0V~5.0V	SOT-23-5	2FX	3K/Reel
LR6200AxxP	1.0V~5.0V	SOT-89-3	2DX	1K/Reel
LR6200AxxPT	1.0V~5.0V	SOT-89-3	2TX	1K/Reel
LR6200BxxF	1.0V~5.0V	DFN1X1-4	GX	10/Reel

(10): "xx" represents output voltage, eg "18" express that the output voltage is 1.8V

(11): Output voltage varies from 1.0Vto 5.0V, 0.1V an interval

(12): The last letter "X" changes along with the output voltage, as figure below

(13): There are additional marking, which relates to the date code

Voltage	1.0	1.2	1.5	1.8	2.5	2.7	2.8	3.0	3.3	3.6	4.0	4.2	5.0
Symble	D	E	F	G	H	I	J	K	L	M	N	T	P

■ TAPE AND REEL INFORMATION

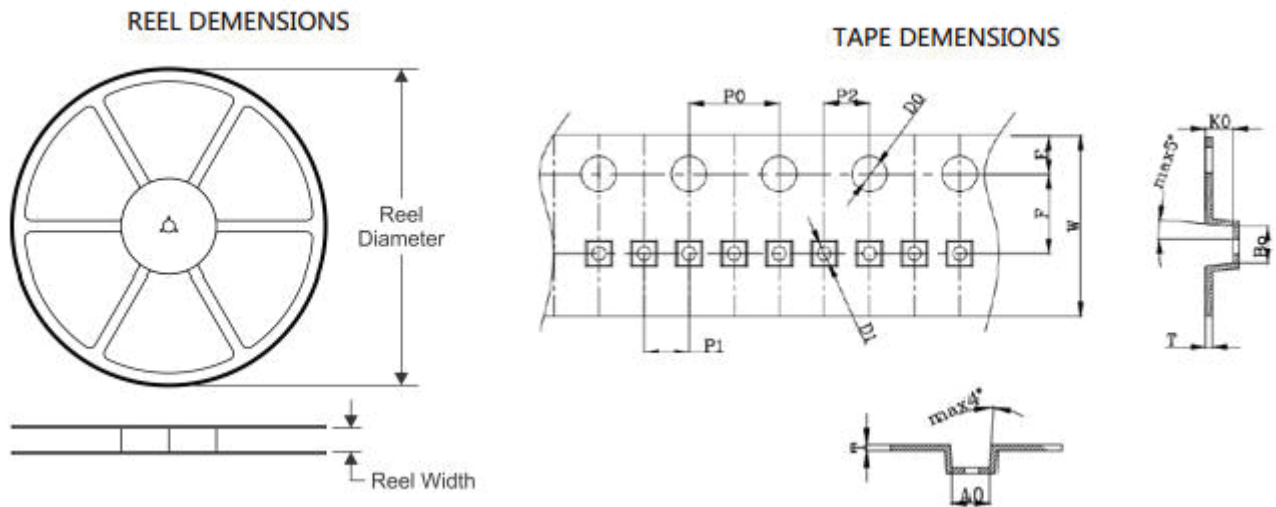

PIN ORIENTATION

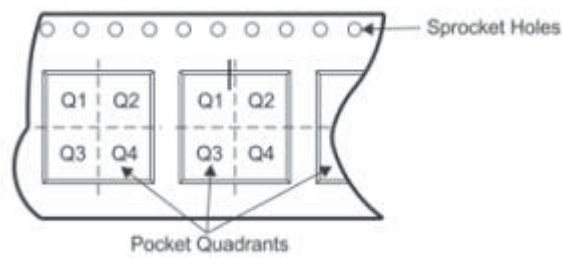

ROLLING ORIENTATION

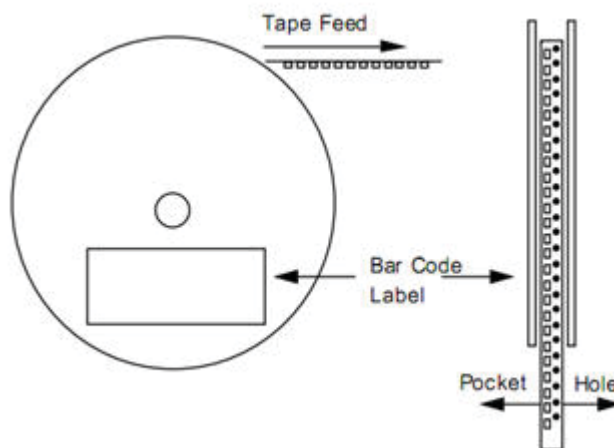

Device	Package	Reel Diameter (mm)	Reel width (mm)	P0 (mm)	P1 (mm)	A0 (mm)	B0 (mm)	K0 (mm)	W (mm)
LR6200AxxM	SOT-23-3	178±1	9.6±1.2	4.00±0.1	4.00±0.1	3.1±0.1	3.28±0.1	1.32±0.1	8.0±0.1
LR6200AxxMA	SOT-23-3	178±1	9.6±1.2	4.00±0.1	4.00±0.1	3.1±0.1	3.28±0.1	1.32±0.1	8.0±0.1
LR6200AxxMC	SOT-23-3	178±1	9.6±1.2	4.00±0.1	4.00±0.1	3.1±0.1	3.28±0.1	1.32±0.1	8.0±0.1
LR6200AxxMY	SOT-23-3	178±1	9.6±1.2	4.00±0.1	4.00±0.1	3.1±0.1	3.28±0.1	1.32±0.1	8.0±0.1
LR6200BxxM	SOT-23-5	178±1	9.6±1.2	4.00±0.1	4.00±0.1	3.25±0.05	3.15±0.05	1.5±0.05	8.0±0.1
LR6200BxxML	SOT-23-5	178±1	9.6±1.2	4.00±0.1	4.00±0.1	3.25±0.05	3.15±0.05	1.5±0.05	8.0±0.1
LR6200AxxMF	SOT-23-5	178±1	9.6±1.2	4.00±0.1	4.00±0.1	3.25±0.05	3.15±0.05	1.5±0.05	8.0±0.1
LR6200AxxP	SOT-89-3	178±1	13.0 ⁺¹ _{0.5}	4.00±0.1	8.00±0.1	4.75±0.1	4.2±0.1	1.75±0.1	12.0 ^{+0.3} _{-0.1}
LR6200AxxPT	SOT-89-3	178±1	13.0 ⁺¹ _{0.5}	4.00±0.1	8.00±0.1	4.75±0.1	4.2±0.1	1.75±0.1	12.0 ^{+0.3} _{-0.1}
LR6200BxxF	DFN1X1-4	178±1	9.6±1.2	4.00±0.1	2.00±0.05	1.16±0.05	1.16±0.05	0.5±0.05	8.0±0.1

单击下面可查看定价，库存，交付和生命周期等信息

[>>LRC\(乐山无线电\)](#)