

LTVS16H15T5G

1-Line Uni-directional TVS Diode

The TVS16H is an uni-directional TVS diode, utilizing leading monolithic silicon technology to provide fast response time and low ESD clamping voltage, making this device an ideal solution for protecting voltage sensitive data and power line. The TVS16H complies with the IEC 61000-4-2 (ESD) standard with $\pm 30\text{kV}$ air and $\pm 30\text{kV}$ contact discharge. It is assembled into an ultra-small 1.6x1.0x0.5mm lead-free DFN package. The small size and high ESD surge protection make TVS16H an ideal choice to protect cell phone, digital cameras, audio players and many other portable applications.

Features

- Ultra small package: 1.6x1.0x0.5mm
- Protects one data or power line
- Low clamping voltage
- 2-pin leadless package
- Complies with following standards:
 - IEC 61000-4-2 (ESD) immunity test
Air discharge: $\pm 30\text{kV}$
Contact discharge: $\pm 30\text{kV}$
 - IEC61000-4-4 (EFT) 52A (5/50ns)
 - IEC61000-4-5 (Lightning) 52A (8/20 μs)
- RoHS Compliant

Applications

- Mobile Phones
- Battery Protection
- Power Line Protection
- Vbat pin for Mobile Devices
- Hand Held Portable Applications

Mechanical Characteristics

- Package: DFN1610-2
- Case Material: "Green" Molding Compound.
- Moisture Sensitivity: Level 1 per J-STD-020

LTVS16H15T5G



MARKING DIAGRAM

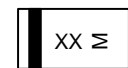

cathode

XX = Specific Device Code
M = Month Code

Ordering information

Device	Shipping
LTVS16H15T5G	8000/Tape&Reel

LTVS16H15T5G

Absolute Maximum Ratings ($T_A=25^{\circ}\text{C}$ unless otherwise specified)

Parameter	Symbol	Value	Unit
Peak Pulse Power (8/20 μs)	Ppk	1900	W
Peak Pulse Current (8/20 μs)	Ipp	52	A
ESD per IEC 61000-4-2 (Air)	VESD	± 30	kV
ESD per IEC 61000-4-2 (Contact)		± 30	
Operating Temperature Range	TJ	-55 to +125	$^{\circ}\text{C}$
Storage Temperature Range	Tstg	-55 to +150	$^{\circ}\text{C}$

Electrical Characteristics ($T_A=25^{\circ}\text{C}$ unless otherwise specified)

Parameter	Symbol	Min	Typ	Max	Unit	Test Condition
Reverse Working Voltage	VRWM			15	V	
Breakdown Voltage	VBR	16.7	18	19.4	V	IT = 1mA
Reverse Leakage Current	IR			0.5	μA	VR = 15V
Forward Voltage	VF		1.0	1.2	V	IF = 10mA
Clamping Voltage	VC			16	V	I _{PP} = 10A (8 x 20 μs pulse)
Clamping Voltage	VC			36	V	I _{PP} = 52A (8 x 20 μs pulse)
Junction Capacitance	CJ		350		pF	VR = 0V, f = 1MHz

LTVS16H15T5G

Typical Performance Characteristics ($T_A=25^{\circ}\text{C}$ unless otherwise Specified)

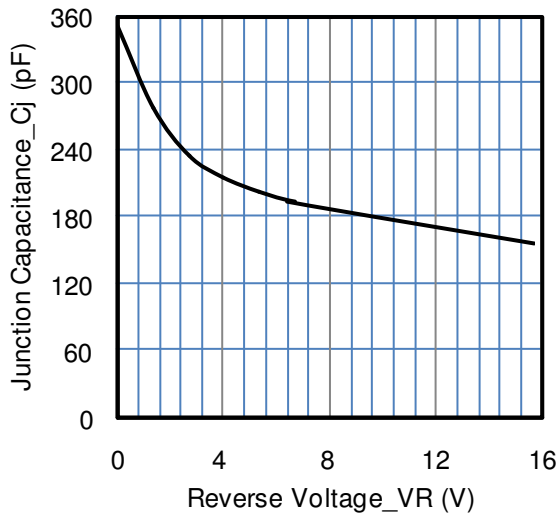

Fig1. Junction Capacitance vs. Reverse Voltage

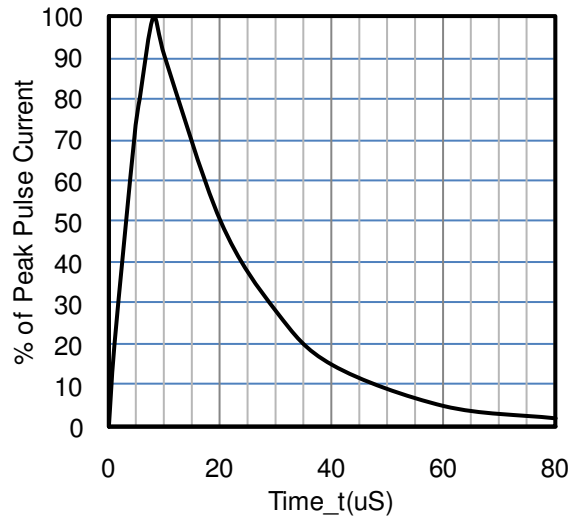

Fig 2. 8 X 20uS Pulse Waveform

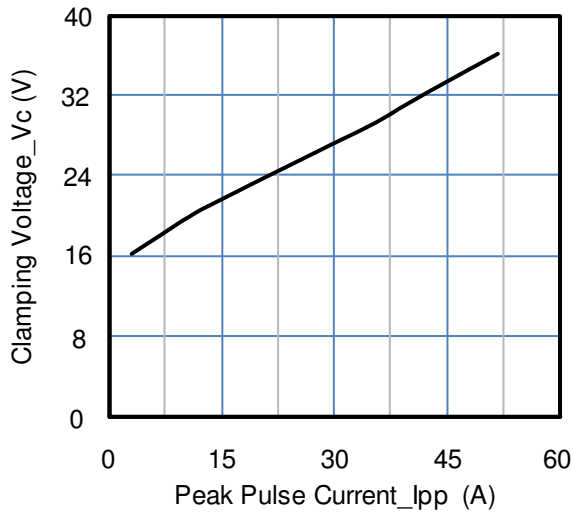

Fig3. Clamping Voltage vs. Peak Pulse Current

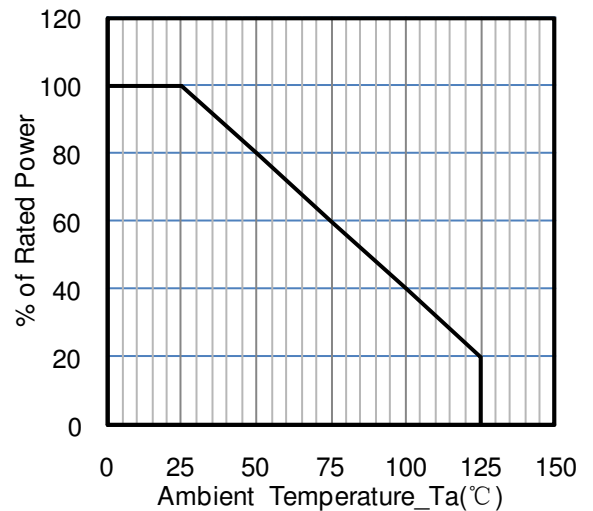
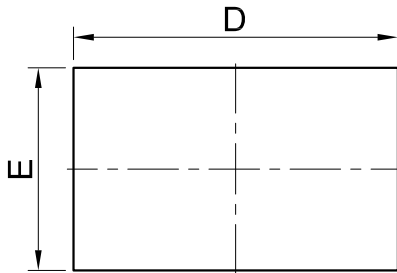

Fig4. Power Derating Curve

LTVS16H15T5G

OUTLINE AND DIMENSIONS



TOP VIEW

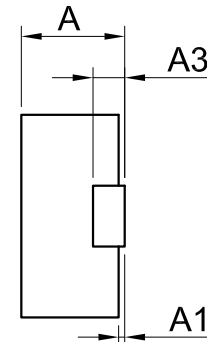

SIDE VIEW

DFN1610			
DIM	MIN	NOR	MAX
A	0.46	0.51	0.56
A1	0.01	0.03	0.05
b	0.75	0.80	0.85
b1	0.25	0.30	0.35
D	1.55	1.60	1.65
E	0.95	1.00	1.05
e	1.10BSC		
L	0.35	0.40	0.45
A3	0.127REF.		
All Dimensions in mm			

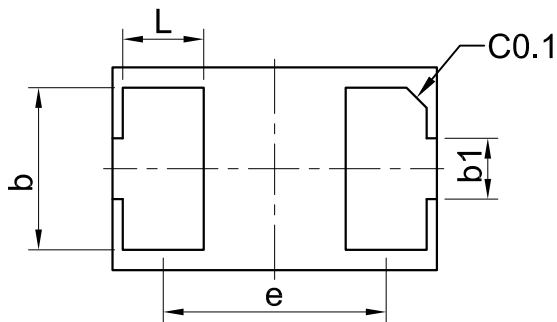

BOTTOM VIEW

SOLDERING FOOTPRINT

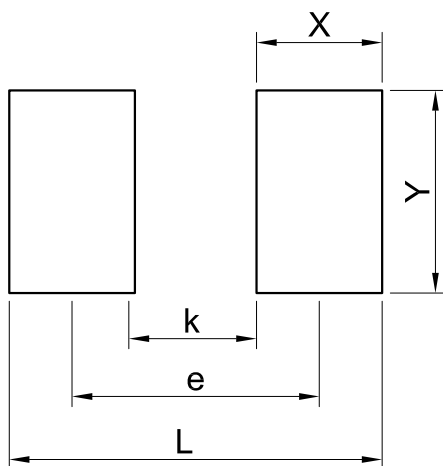

DFN1610	
DIM	(mm)
X	0.62
Y	1.00
L	1.84
e	1.22
K	0.60

单击下面可查看定价，库存，交付和生命周期等信息

[>>LRC\(乐山无线电\)](#)