

LRB421LT1G

S-LRB421LT1G

Schottky barrier diode

1. FEATURES

- Low current rectification
- Small mold type. (SOT-23)
- Low IR
- High reliability.
- We declare that the material of product compliance with RoHS requirements and Halogen Free.
- S- prefix for automotive and other applications requiring unique site and control change requirements; AEC-Q101 qualified and PPAP capable.

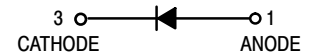
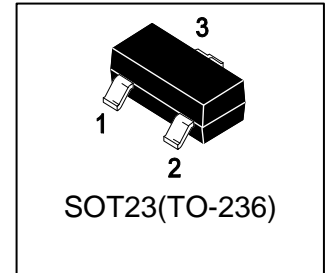

2. DEVICE MARKING AND RESISTOR VALUES

Device	Marking	Shipping
LRB421LT1G	D3C	3000/Tape&Reel
LRB421LT3G	D3C	10000/Tape&Reel

3. MAXIMUM RATINGS(Ta = 25°C)

Parameter	Symbol	Limits	Unit
Reverse voltage (repetitive peak)	VRM	40	V
Reverse voltage (DC)	VR	40	V
Average rectified forward current(Note 1)	IO	100	mA
Forward current surge peak (60Hz · 1cyc)(Note 1)	IFSM	1	A
Junction temperature	Tj	125	°C
Storage temperature	Tstg	-40~+125	°C

1.Rating of per diode

4. ELECTRICAL CHARACTERISTICS (Ta= 25°C)

CHARACTERISTICS	Symbol	Min	Typ	Max	Unit
Forward voltage (IF =100mA)	VF	-	-	0.55	V
(IF =10mA)		-	-	0.34	
Reverse current (VR=10V)	IR	-	-	30	μA
Capacitance between terminal (VR =10V , f=1MHz)	Ct	-	4	-	pF

5.ELECTRICAL CHARACTERISTICS CURVES

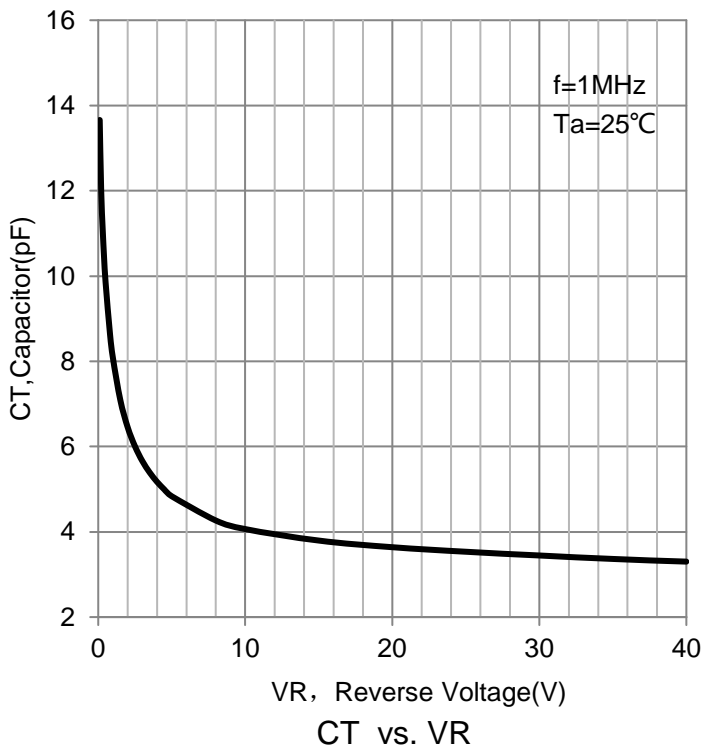
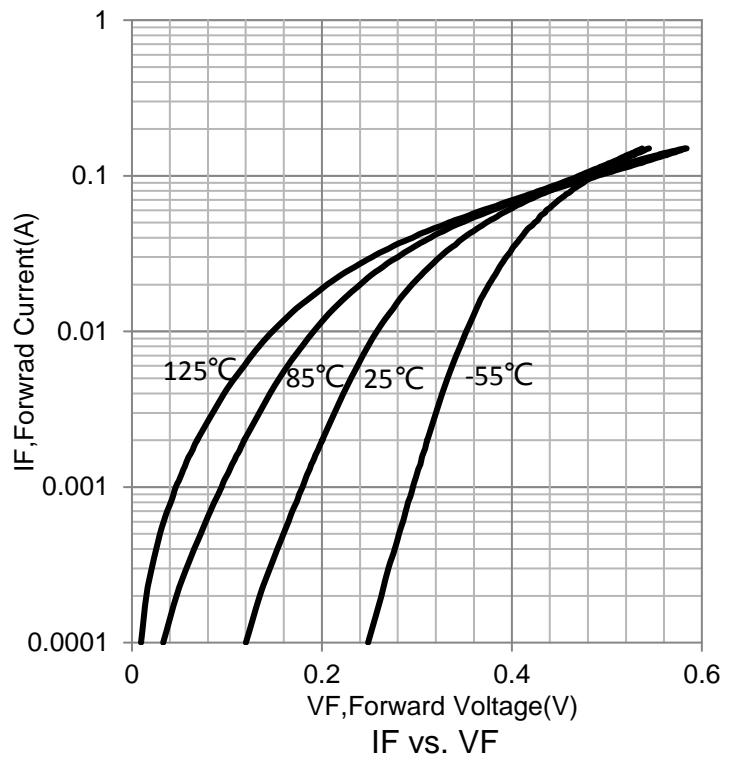
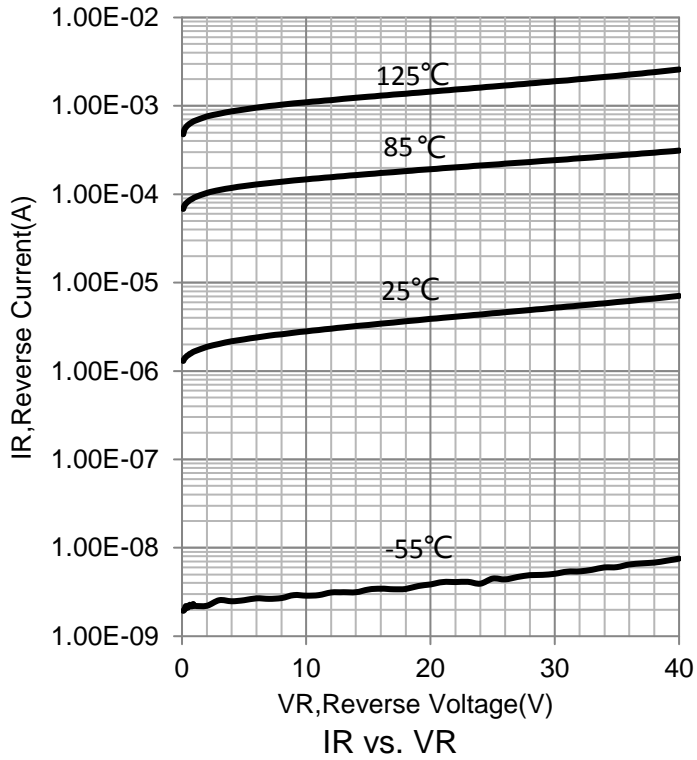

6. OUTLINE AND DIMENSIONS

Notes:

1. DIMENSIONING AND TOLERANCING PER ANSI Y14.5M, 1982.
2. CONTROLLING DIMENSION: MILLIMETERS.
3. MAXIMUM LEAD THICKNESS INCLUDES LEAD FINISH. MINIMUM LEAD THICKNESS IS THE MINIMUM THICKNESS OF BASE MATERIAL.
4. DIMENSIONS D AND E DO NOT INCLUDE MOLD FLASH, PROTRUSIONS OR GATE BURRS.

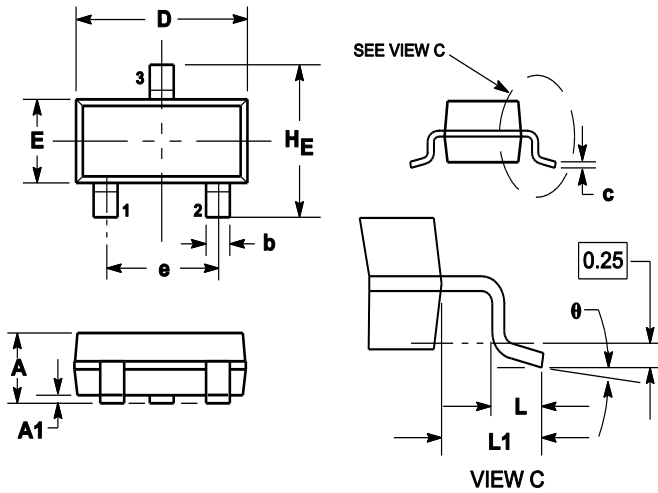

DIM	MILLIMETERS			INCHES		
	MIN	NOM	MAX	MIN	NOM	MAX
A	0.89	1	1.11	0.035	0.04	0.044
A1	0.01	0.06	0.1	0.001	0.002	0.004
b	0.37	0.44	0.5	0.015	0.018	0.02
c	0.09	0.13	0.18	0.003	0.005	0.007
D	2.80	2.9	3.04	0.11	0.114	0.12
E	1.20	1.3	1.4	0.047	0.051	0.055
e	1.78	1.9	2.04	0.07	0.075	0.081
L	0.10	0.2	0.3	0.004	0.008	0.012
L1	0.35	0.54	0.69	0.014	0.021	0.029
HE	2.10	2.4	2.64	0.083	0.094	0.104
theta	0°	---	10°	0°	---	10°

7. SOLDERING FOOTPRINT

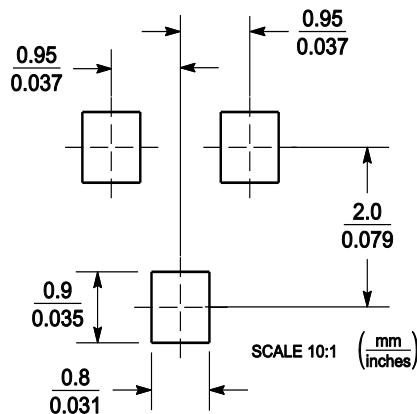

单击下面可查看定价，库存，交付和生命周期等信息

[>>LRC\(乐山无线电\)](#)