

# LP3407LT1G

## 30V P-Channel Enhancement-Mode MOSFET

### 1. FEATURES

- VDS = -30V
- ID=-4.1A @ VGS = -10V
- RDS(ON) < 70mΩ(VGS = -10V)
- RDS(ON) < 100mΩ(VGS = -4.5V)
- We declare that the material of product compliance with RoHS requirements and Halogen Free.

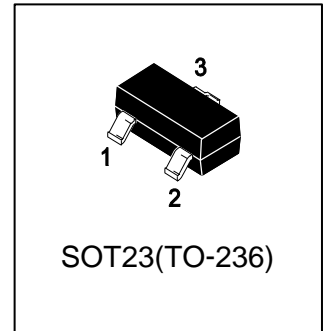

### 2. DEVICE MARKING AND ORDERING INFORMATION

Device	Marking	Shipping
LP3407LT1G	A07	3000/Tape&Reel
LP3407LT3G	A07	10000/Tape&Reel

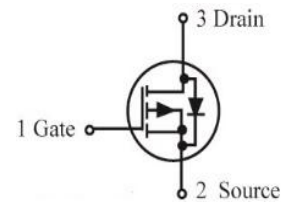

### 3. MAXIMUM RATINGS(Ta = 25°C)

Parameter	Symbol	Limits	Unit
Drain-Source Voltage	VDSS	-30	V
Gate-to-Source Voltage	VGS	±20	V
Continuous Drain Current	ID	Ta=25°C	-4.1
		Ta=70°C	-3.5
Pulsed Drain Current (Note 3)	IDM	-25	A
Power Dissipation (Note 2)	PD	Ta=25°C	1.4
		Ta=70°C	0.9
Junction and Storage Temperature Range	Tj,Tstg	-55~+150	°C

### 4. THERMAL CHARACTERISTICS

Parameter	Symbol	Typ.	Max	Unit
Thermal Resistance, Junction-to-Ambient (Note 1&4)	RθJA	t ≤ 10s	70	90
		Steady State	100	125
Maximum Junction-to-Lead	RθJL	63	80	°C/W

- 1.The value of RθJA is measured with the device mounted on 1in 2 FR-4 board with 2oz. Copper, in a still air environment with TA =25°C. The value in any given application depends on the user's specific board design. The current rating is based on the t ≤ 10s thermal resistance rating.
- 2.Repetitive rating, pulse width limited by junction temperature.
- 3.The RθJA is the sum of the thermal impedance from junction to lead RθJL and lead to ambient.

**5. ELECTRICAL CHARACTERISTICS (Ta= 25°C)**

Characteristic	Symbol	Min.	Typ.	Max.	Unit	
<b>STATIC PARAMETERS</b>						
Drain-Source Breakdown Voltage (VGS = 0, ID = -250μA)	VBRDSS	-30	-	-	V	
Zero Gate Voltage Drain Current (VGS = 0, VDS = -24 V) (VGS = 0, VDS = -24 V, TJ = 55°C)	IDSS	-	-	-1 -5	μA	
Gate Leakage Current (VDS = 0V, VGS = ±20V )	IGSS	-	-	±100	nA	
Gate Threshold Voltage (VDS = VGS, ID = -250μA)	VGS(th)	-1	-2	-3	V	
On state drain current (VGS = -10V, VDS = -5V)	ID(ON)	-25			A	
Static Drain-Source On-State Resistance (VGS = -10V, ID = -4.1A) (VGS = -10V, ID = -4.1A, TJ = 125°C) (VGS = -4.5V, ID = -3A)	RDS(on)	-	-	70 95 100	mΩ	
Forward Transconductance (VDS = -5V, ID = -4A)	gfs	-	10	-	S	
Forward Voltage (VGS = 0 V, IS = -1A)	VSD	-	-0.7	-1	V	
Maximum Body-Diode Continuous Current	IS	-	-	-2	A	
<b>DYNAMIC PARAMETERS</b>						
Input Capacitance (VGS = 0 V, f = 1.0MHz, VDS = -15 V)	Ciss	-	520	625	pF	
Output Capacitance (VGS = 0 V, f = 1.0MHz, VDS = -15 V)	Coss	-	100	130		
Reverse Transfer Capacitance (VGS = 0 V, f = 1.0MHz, VDS = -15 V)	Crss	-	65	90		
Gate resistance (VGS = 0V, VDS = 0V, f = 1MHz)	Rg	3.5	7.5	11.5	Ω	
<b>SWITCHING PARAMETERS</b>						
Total Gate Charge	(VGS = -10V, VDS = -15V, ID = -4A)	Qg(10V)	7.4	9.2	11	nc
Total Gate Charge		Qg(4.5V)	3.7	4.6	6	
Gate-Source Charge		Qgs	1.3	1.6	1.9	
Gate-Drain Charge		Qgd	1.3	2.2	3.1	
Turn-On Delay Time	(VDS = -15V, RL = 3.6 Ω, VGS = -10V, RG = 3Ω)	td(on)	-	7.5	-	ns
Rise Time		tr	-	5.5	-	
Turn-Off Delay Time		td(off)	-	19	-	
Fall Time		tf	-	7	-	
Body Diode Reverse Recovery Time (IF = -4A, di/dt = 100A/μs)		trr	8.8	11	13	
Body Diode Reverse Recovery Charge (IF = -4A, di/dt = 100A/μs)		Qrr	4	5.3	6.4	nc

6.ELECTRICAL CHARACTERISTICS CURVES

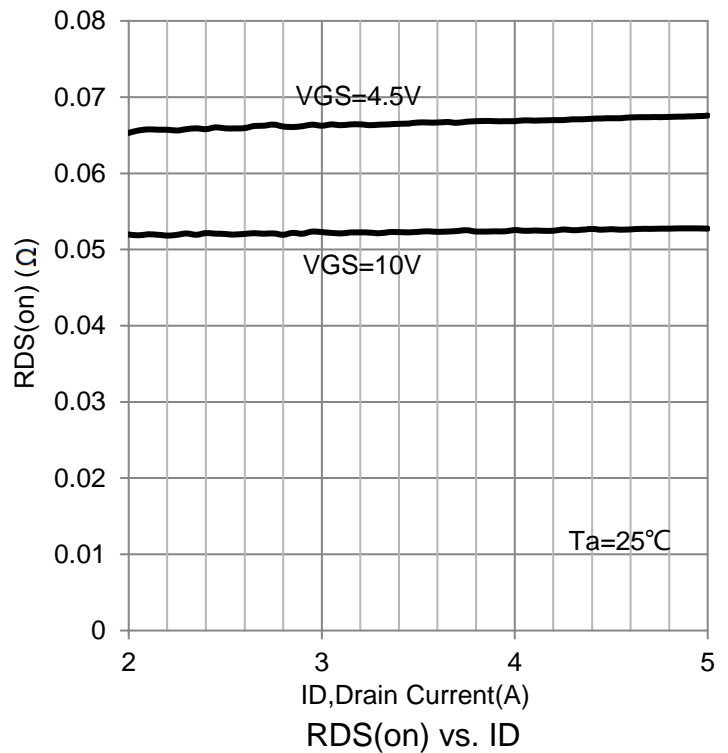
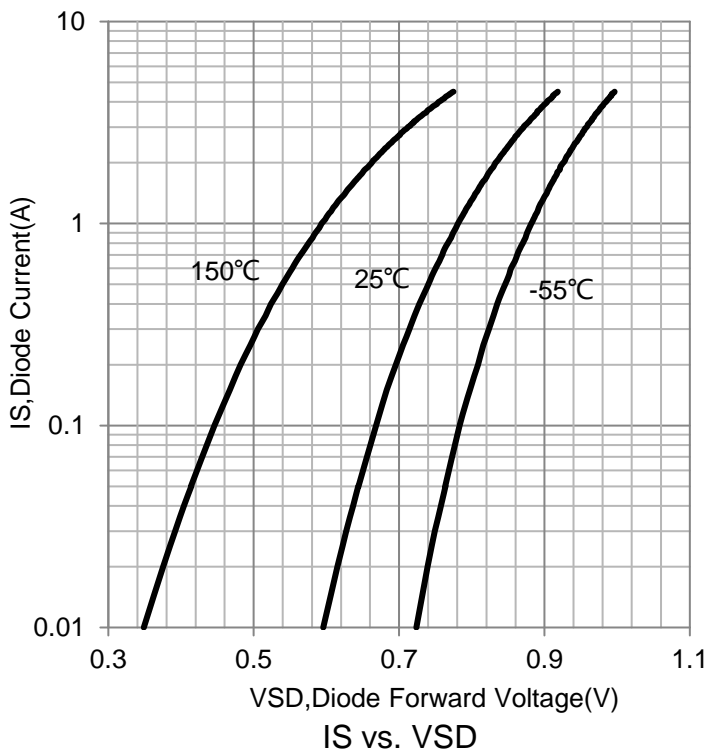
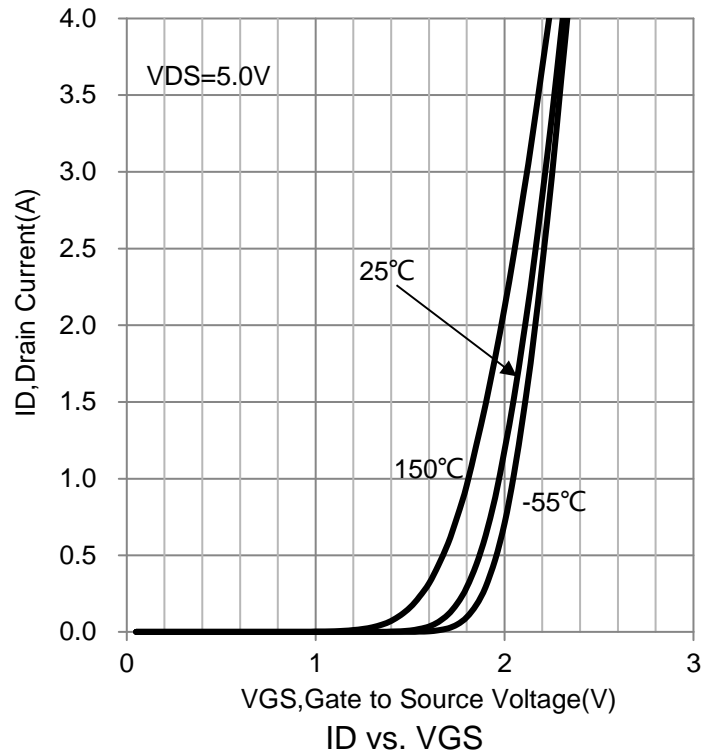
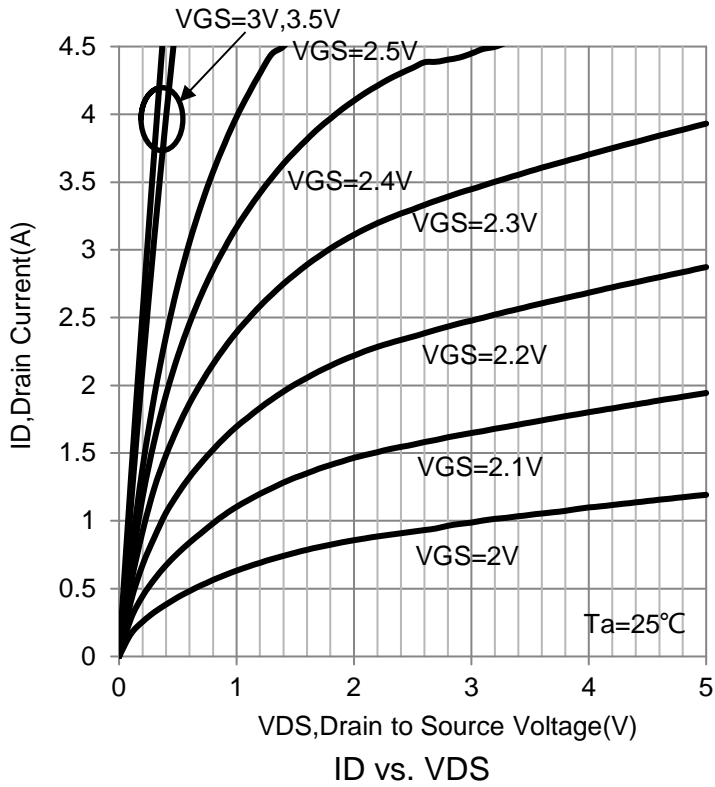

6.ELECTRICAL CHARACTERISTICS CURVES(Con.)

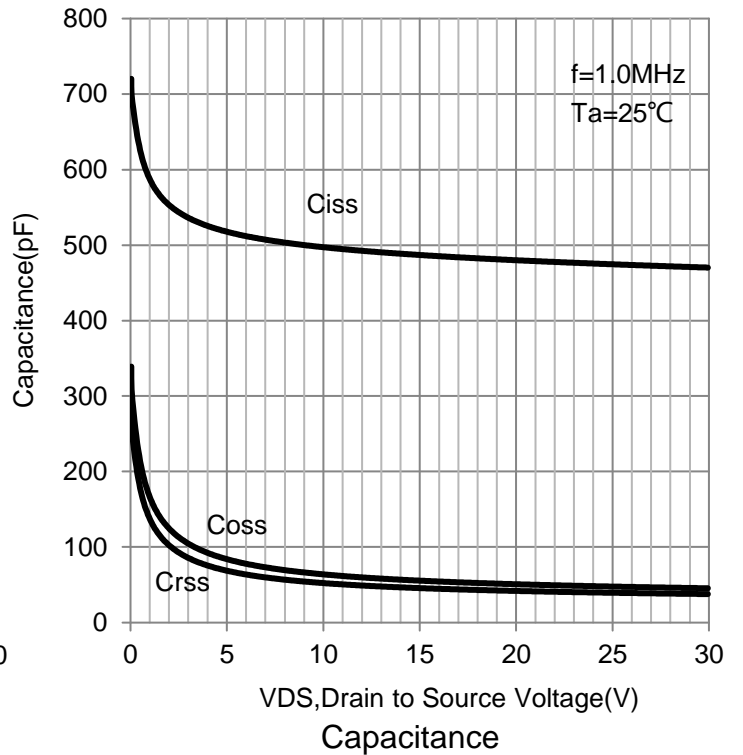
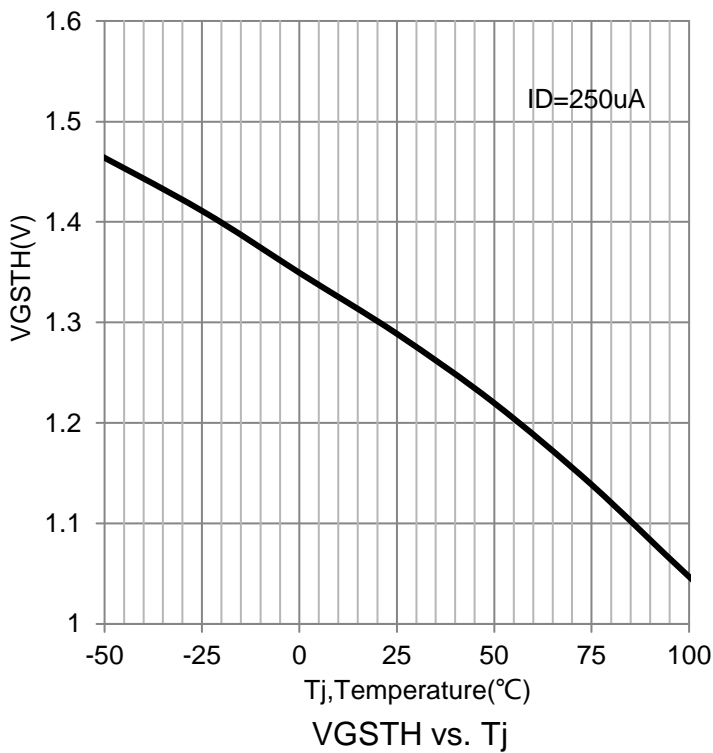
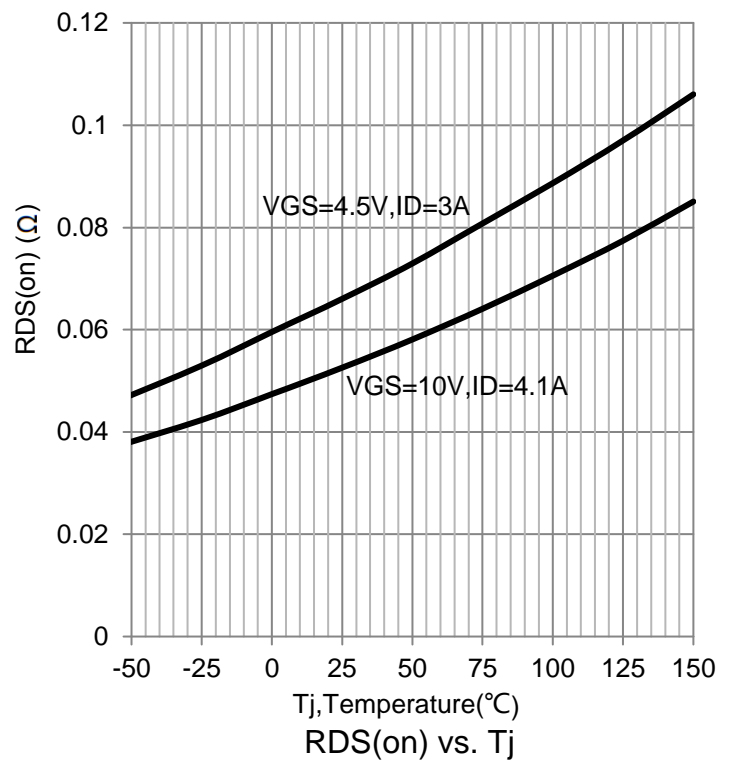
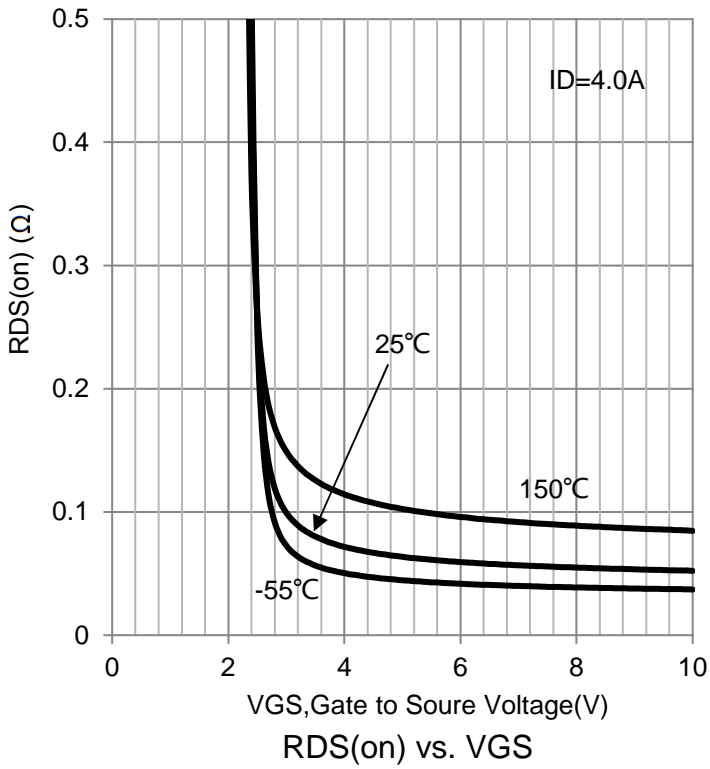

**7. OUTLINE AND DIMENSIONS**

Notes:

1. DIMENSIONING AND TOLERANCING PER ANSI Y14.5M, 1982.
2. CONTROLLING DIMENSION: MILLIMETERS.
3. MAXIMUM LEAD THICKNESS INCLUDES LEAD FINISH. MINIMUM LEAD THICKNESS IS THE MINIMUM THICKNESS OF BASE MATERIAL.
4. DIMENSIONS D AND E DO NOT INCLUDE MOLD FLASH, PROTRUSIONS OR GATE BURRS.

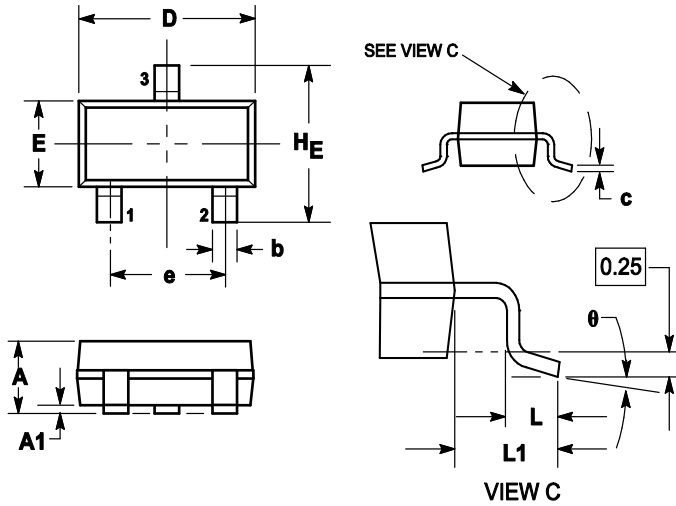

DIM	MILLIMETERS			INCHES		
	MIN	NOM	MAX	MIN	NOM	MAX
A	0.89	1	1.11	0.035	0.04	0.044
A1	0.01	0.06	0.1	0.001	0.002	0.004
b	0.37	0.44	0.5	0.015	0.018	0.02
c	0.09	0.13	0.18	0.003	0.005	0.007
D	2.80	2.9	3.04	0.11	0.114	0.12
E	1.20	1.3	1.4	0.047	0.051	0.055
e	1.78	1.9	2.04	0.07	0.075	0.081
L	0.10	0.2	0.3	0.004	0.008	0.012
L1	0.35	0.54	0.69	0.014	0.021	0.029
HE	2.10	2.4	2.64	0.083	0.094	0.104
θ	0°	---	10°	0°	---	10°

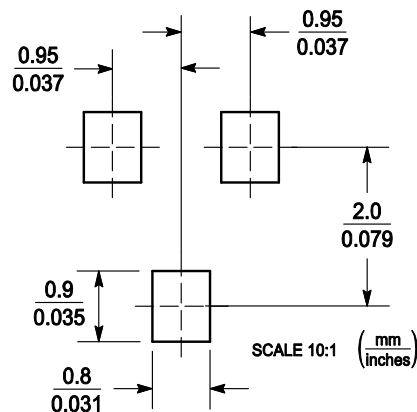
**8. SOLDERING FOOTPRINT**

单击下面可查看定价，库存，交付和生命周期等信息

[>>LRC\(乐山无线电\)](#)

[>>点击查看相关商品](#)