

LDN3370DT2AG

30V N-Channel (D-S) MOSFET

1. FEATURES

- VDS= 30V
- RDS(ON), VGS@10V, IDS@5.1A = 38mΩ
- RDS(ON), VGS@4.5V, IDS@4.5A = 48mΩ
- We declare that the material of product compliance with RoHS requirements and Halogen Free.
- ESD protected

2. APPLICATIONS

- Power Routing
- Li Ion Battery Packs
- Level Shifting and Driver Circuits

3. DEVICE MARKING AND ORDERING INFORMATION

Device	Marking	Shipping
LDN3370DT2AG	37D	4000/Tape&Reel

4. MAXIMUM RATINGS(Ta = 25°C)

Parameter	Symbol	Limits	Unit
Drain–Source Voltage	VDS	30	V
Gate–to–Source Voltage	VGS	±20	V
Continuous Drain Current(Note 1)	ID	TA=25°C	5.1
		TA=70°C	4
Pulsed Drain Current(Note 2)	IDM	20	A
Continuous Source Current(Note 1)	IS	1.7	A
Power Dissipation(Note 1)	PD	TA=25°C	1.3
		TA=70°C	0.8
Operating Junction and Storage Temperature Range	TJ,TSTG	-55~+150	°C

5. THERMAL CHARACTERISTICS

Parameter	Symbol	Limits	Unit
Maximum Junction-to-Ambient(Note 1)	RθJA	t ≤ 10 sec	100
		Steady State	166

- 1.Surface Mounted on 1" x 1" FR4 Board.
- 2.Pulse width limited by maximum junction temperature

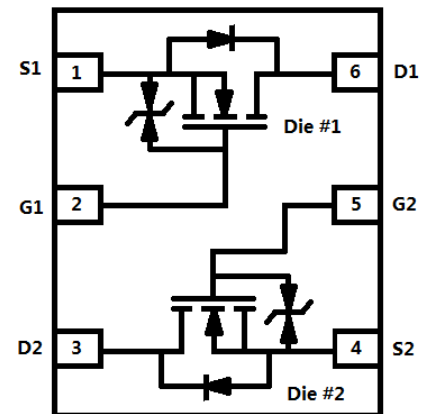
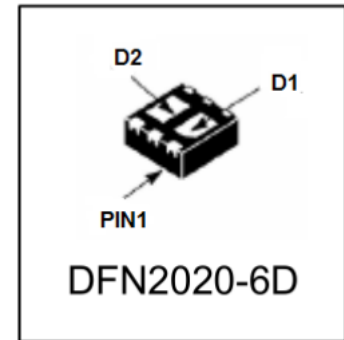

6. ELECTRICAL CHARACTERISTICS (Ta= 25°C)

Static

Characteristic	Symbol	Min.	Typ.	Max.	Unit
Drain-Source Breakdown Voltage (VGS = 0, ID = 250μA)	V(BR)DSS	30	-	-	V
Zero Gate Voltage Drain Current (VDS = 24 V, VGS = 0 V) (VDS = 24 V, VGS = 0 V, TJ = 55°C)	IDSS	-	-	1 10	μA
Gate-Source Threshold Voltage (VDS = VGS, ID = 250 μA)	VGS(th)	0.7	-	-	V
Gate-Body Leakage Current (VDS = 0 V, VGS = ±16 V)	IGSS	-	-	±10	μA
On-State Drain Current(Note 3) (VDS = 5 V, VGS = 10 V)	ID(on)	7.5	-	-	A
Drain-Source On-Resistance(Note 3) (VGS = 10 V, ID = 5 A) (VGS = 4.5 V, ID = 4 A)	RDS(on)	-	25 40	38 52	mΩ
Forward Transconductance(Note 3) (VDS = 15 V, ID = 5 A)	gfs	-	14	-	S
Diode Forward Voltage(Note 3) (IS = 0.85 A, VGS = 0 V)	VSD	-	0.75	-	V

DYNAMIC

Total Gate Charge	(VDS = 15 V, VGS = 4.5 V, ID = 2 A)	Qg	-	5	-	nC
Gate-Source Charge		Qgs	-	0.8	-	
Gate-Drain Charge		Qgd	-	2.3	-	
Turn-On Delay Time	(VDS = 15 V, RL = 7.5 Ω, ID = 2 A, VGEN = 10 V, RGEN = 6 Ω)	td(on)	-	3	-	ns
Rise Time		tr	-	9	-	
Turn-Off Delay Time		td(off)	-	22	-	
Fall Time		tf	-	8	-	
Input Capacitance	(VDS = 15 V, VGS = 0 V, f = 1 MHz)	Ciss	-	419	-	pF
Output Capacitance		Coss	-	58	-	
Reverse Transfer Capacitance		Crss	-	53	-	

3.Pulse Test: Pulse Width ≤300 μs, Duty Cycle ≤2.0%.

7. ELECTRICAL CHARACTERISTICS CURVES

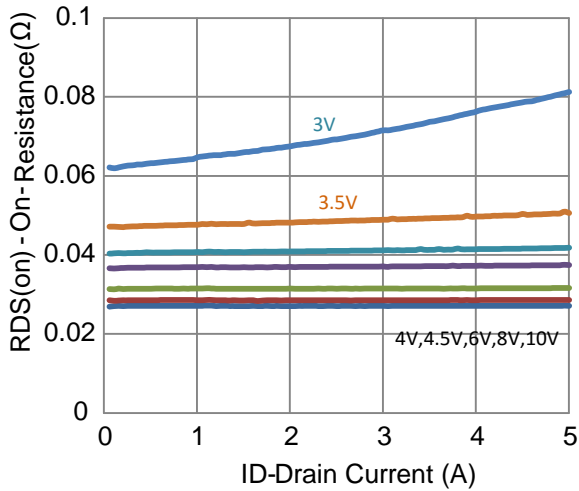

On-Resistance vs. Drain Current

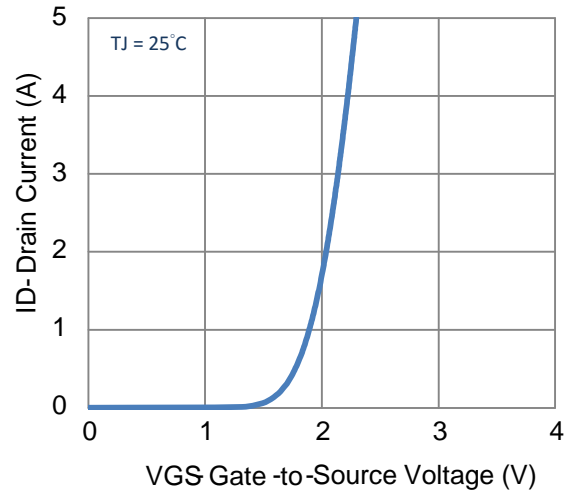

Transfer Characteristics

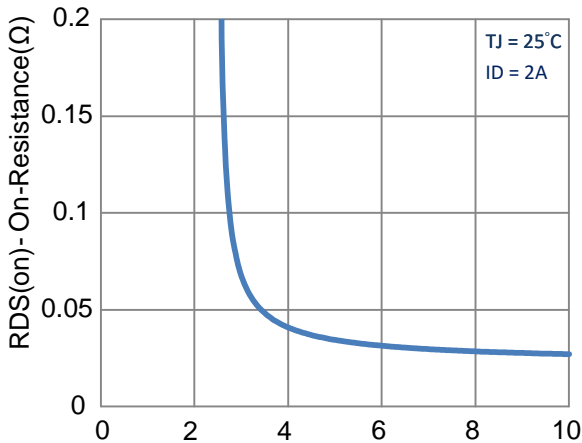

On-Resistance vs. Gate-to-Source Voltage

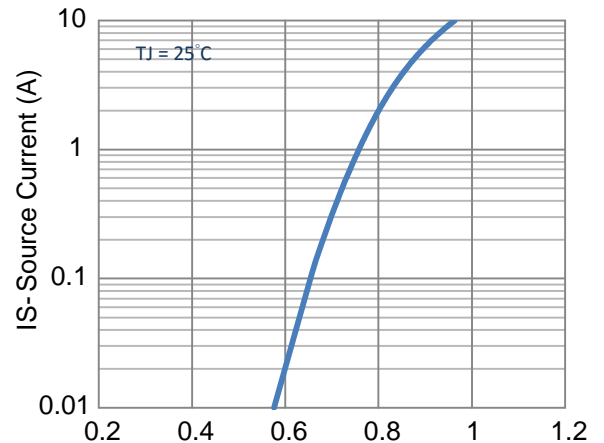

Drain-to-Source Forward Voltage

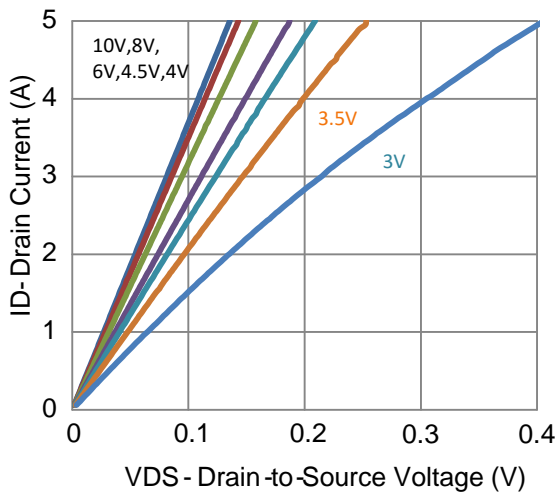

Output Characteristics

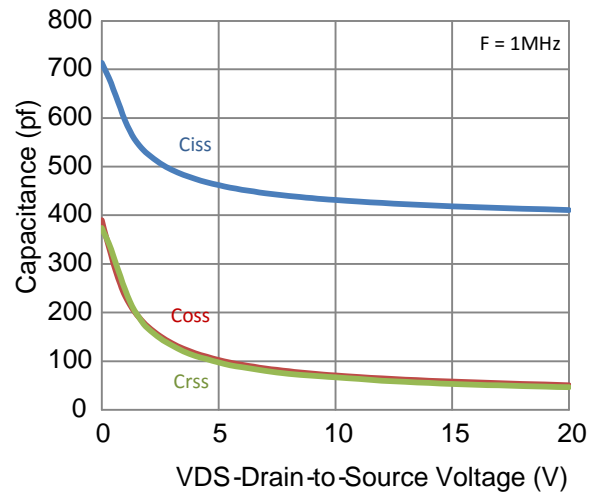

Capacitance

7.ELECTRICAL CHARACTERISTICS CURVES (Con.)

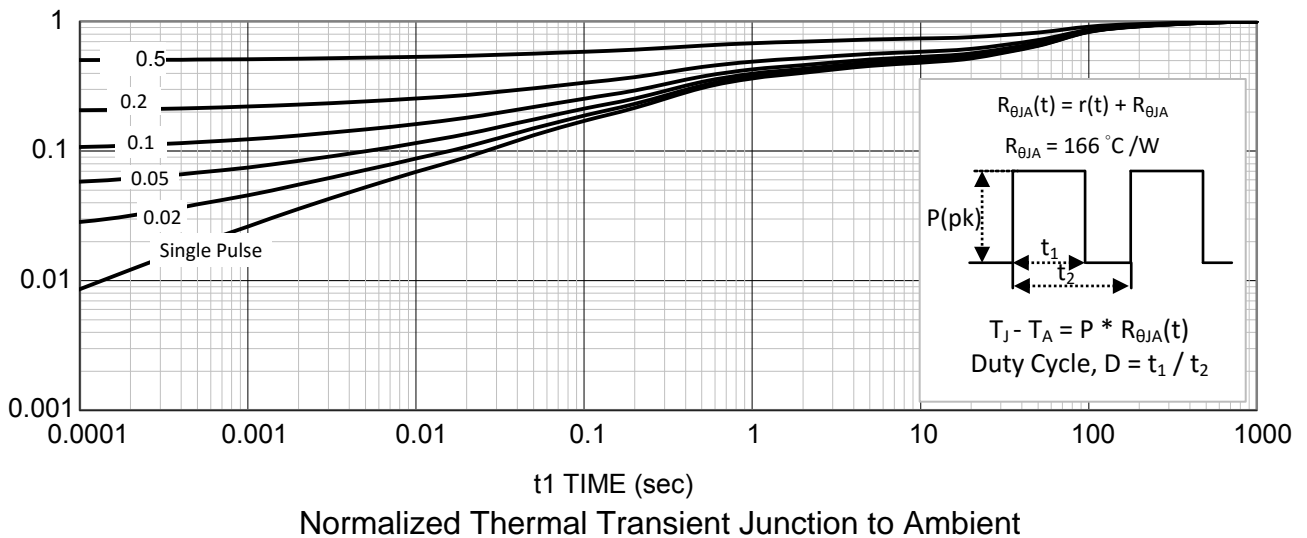
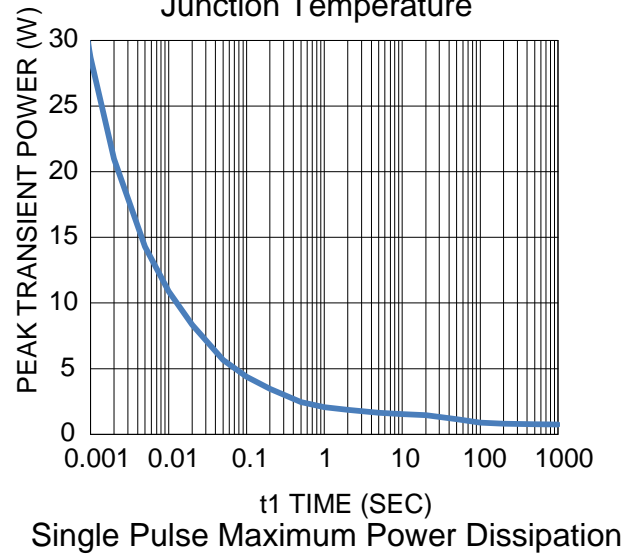
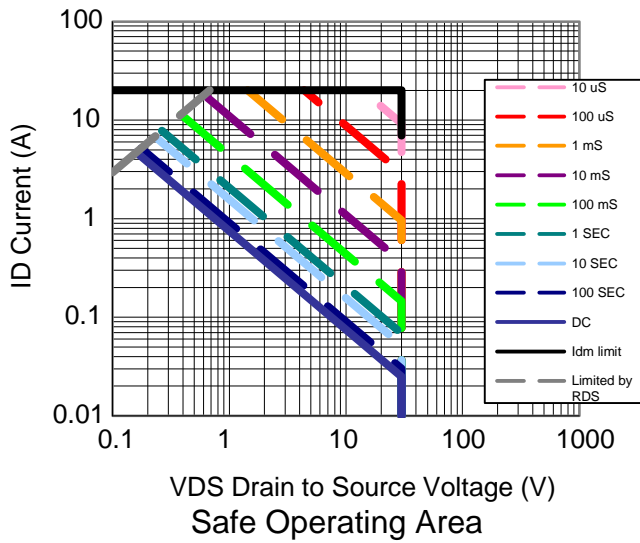
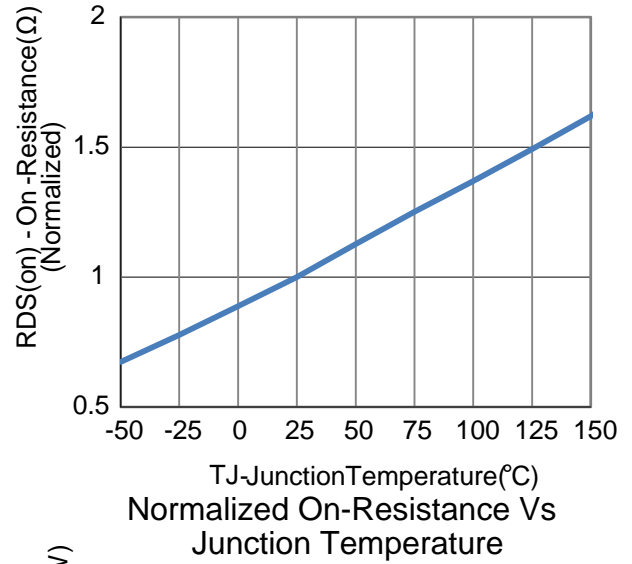
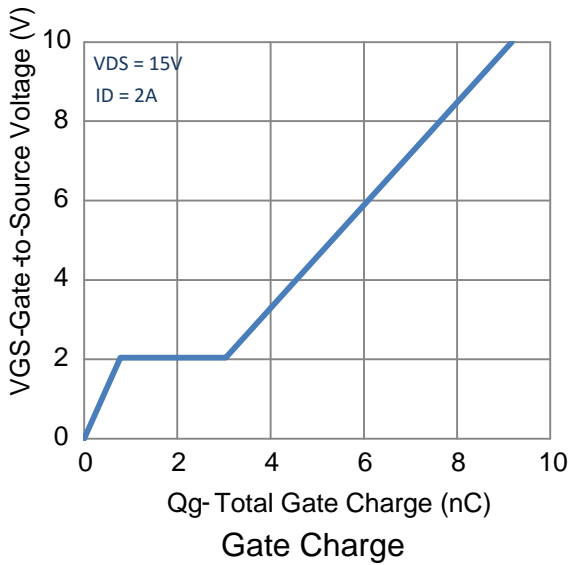

8. OUTLINE AND DIMENSIONS

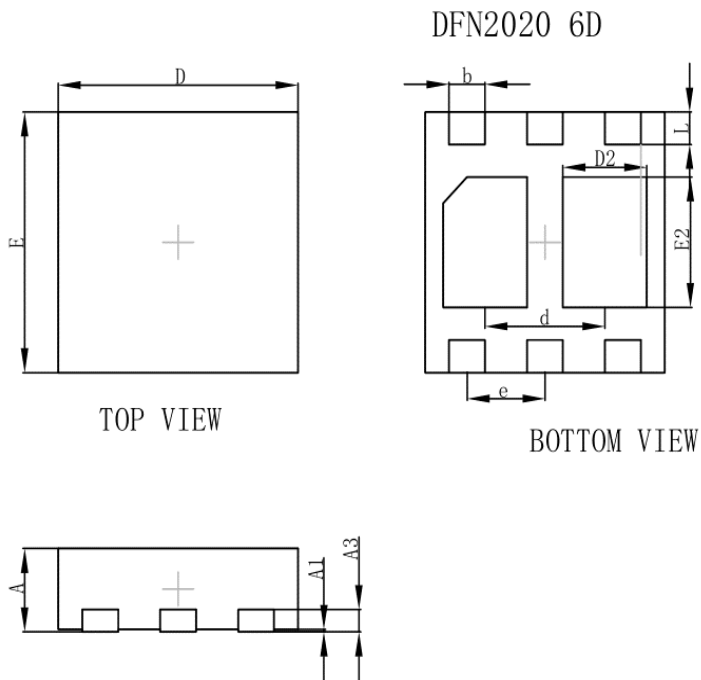

DFN2020-6D			
Dim	Min	Typ	Max
D	1.95	2.00	2.05
E	1.95	2.00	2.05
e	-	0.65	-
L	0.20	0.25	0.30
b	0.25	0.30	0.35
d	-	1.00	-
A	0.60	0.65	0.70
A1	0.00	0.02	0.05
A3	-	0.152	-
E2	0.95	1.00	1.05
D2	0.65	0.70	0.75
All Dimensions in mm			

9. SOLDERING FOOTPRINT

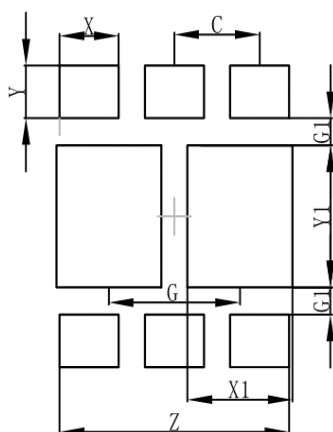

Dimensions	(mm)
X	0.45
Y	0.37
X1	0.80
Y1	1.00
C	0.65
G	1.00
G1	0.19
Z	1.75

单击下面可查看定价，库存，交付和生命周期等信息

[>>LRC\(乐山无线电\)](#)