

LPB2305LT1G

30V P-Channel Enhancement-Mode MOSFET

1. FEATURES

- $V_{DS} = -30V$
- $R_{DS(ON)}, V_{GS}@-10V, I_{DS}@-4.2A = 70m\Omega$
- $R_{DS(ON)}, V_{GS}@-4.5V, I_{DS}@-4.0A = 85m\Omega$
- $R_{DS(ON)}, V_{GS}@-2.5V, I_{DS}@-1.0A = 130m\Omega$
- We declare that the material of product compliance with RoHS requirements and Halogen Free.

2. APPLICATIONS

- Advanced trench process technology
- High density cell design for ultra low on-resistance.

3. DEVICE MARKING AND ORDERING INFORMATION

Device	Marking	Shipping
LPB2305LT1G	P05	3000/Tape&Reel
LPB2305LT3G	P05	10000/Tape&Reel

4. MAXIMUM RATINGS($T_a = 25^\circ C$)

Parameter	Symbol	Limits	Unit
Drain–Source Voltage	V_{DSS}	-30	V
Gate–to–Source Voltage – Continuous	V_{GS}	± 14	V
Drain Current			A
– Continuous $T_A = 25^\circ C$	ID	-4.2	
– Pulsed (Note 1)	IDM	-30	

5. THERMAL CHARACTERISTICS

Parameter	Symbol	Limits	Unit
Power Dissipation	PD	1.4	W
Thermal Resistance, Junction–to–Ambient(Note 2)	$R_{\theta JA}$	140	$^\circ C/W$
Junction and Storage temperature	T_J, T_{stg}	$-55 \sim +150$	$^\circ C$

1.Repetitive Rating: Pulse width limited by the maximum junction temperature.

2.1-in² 2oz Cu PCB board.

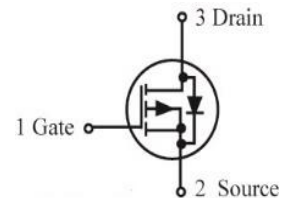
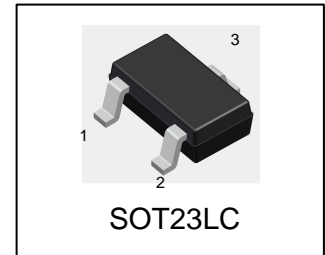

6. ELECTRICAL CHARACTERISTICS (Ta= 25°C)

OFF CHARACTERISTICS

Characteristic	Symbol	Min.	Typ.	Max.	Unit
Drain–Source Breakdown Voltage (VGS = 0, ID = -250μA)	VBRDSS	-30	-	-	V
Zero Gate Voltage Drain Current (VGS = 0, VDS = -24 V)	IDSS	-	-	-1	μA
Gate–Body Leakage Current, Forward (VGS = 14 V)	IGSSF	-	-	100	nA
Gate–Body Leakage Current, Reverse (VGS = -14 V)	IGSSR	-	-	-100	nA

ON CHARACTERISTICS (Note 3)

Forward Transconductance (VDS = -5V, ID = -5A)	gfs	7.0	11	-	S
Gate Threshold Voltage (VDS = VGS, ID = -250μA)	VGS(th)	-0.7	-	-1.3	V
Static Drain–Source On–State Resistance (VGS = -10 V, ID = -4.2 A)	RDS(on)	-	53	70	mΩ
(VGS = -4.5 V, ID = -4 A)		-	64	85	
(VGS = -2.5 V, ID = -1 A)		-	86	130	

DYNAMIC CHARACTERISTICS

Input Capacitance (VGS = 0 V, f = 1.0MHz, VDS = -15 V)	Ciss	-	826.18	-	pF
Output Capacitance (VGS = 0 V, f = 1.0MHz, VDS = -15 V)	Coss	-	90.74	-	pF
Reverse Transfer Capacitance (VGS = 0 V, f = 1.0MHz, VDS = -15 V)	Crss	-	53.18	-	pF

SWITCHING CHARACTERISTICS

Turn-On Delay Time	(VDD = -15V, RL = 3.6Ω ID = -1A, VGEN = -10V RG = 6Ω)	td(on)	-	11.36	-	ns
Rise Time		tr	-	2.32	-	
Turn-Off Delay Time		td(off)	-	34.88	-	
Fall Time		tf	-	3.52	-	

SOURCE–DRAIN DIODE CHARACTERISTICS

Forward Voltage (VGS = 0 V, ISD = -1 A)	VSD	-	-	-1	V
--	-----	---	---	----	---

3.Pulse Test: Pulse Width ≤300 μs, Duty Cycle ≤2.0%.

7. ELECTRICAL CHARACTERISTICS CURVES

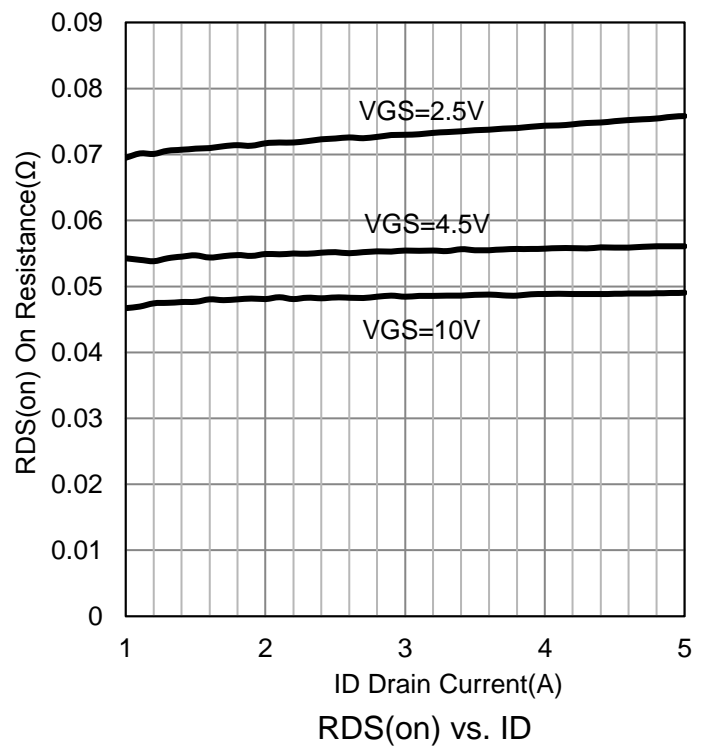
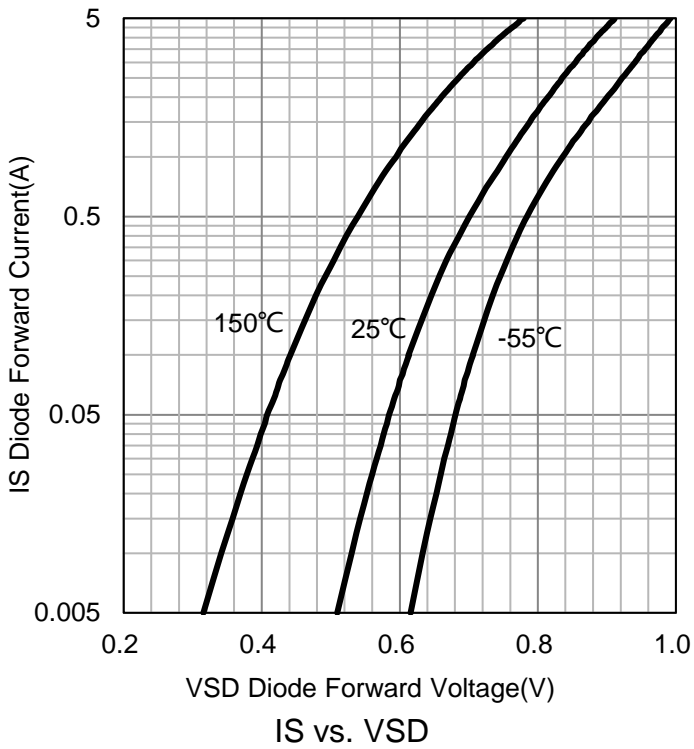
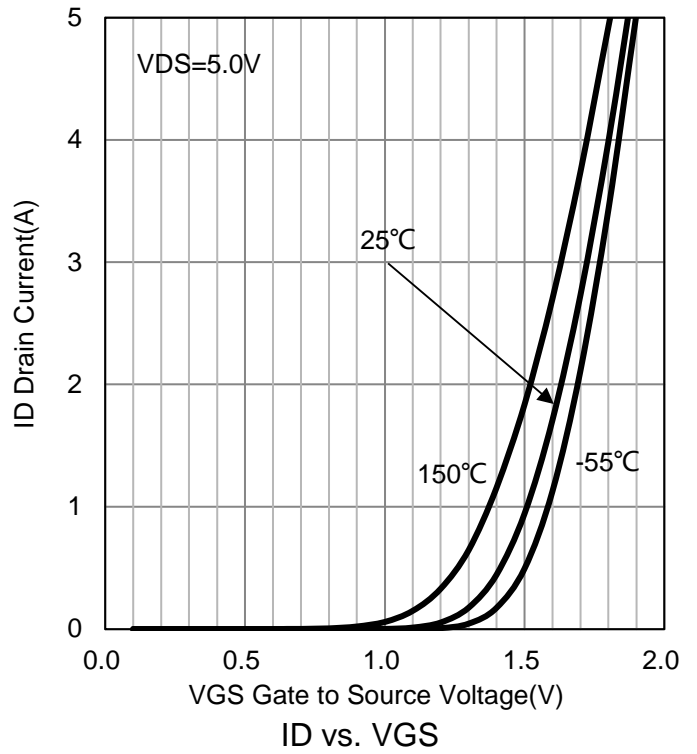
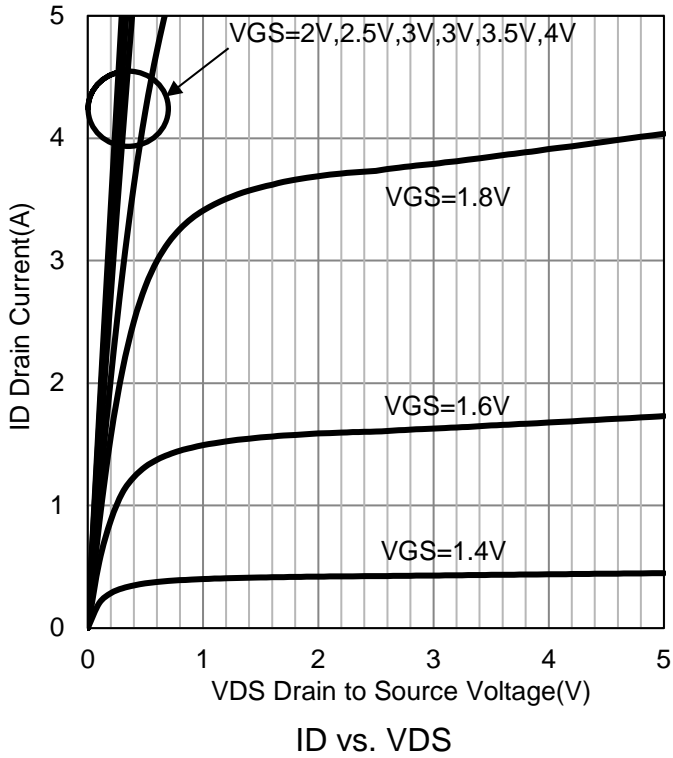

7. ELECTRICAL CHARACTERISTICS CURVES (Con.)

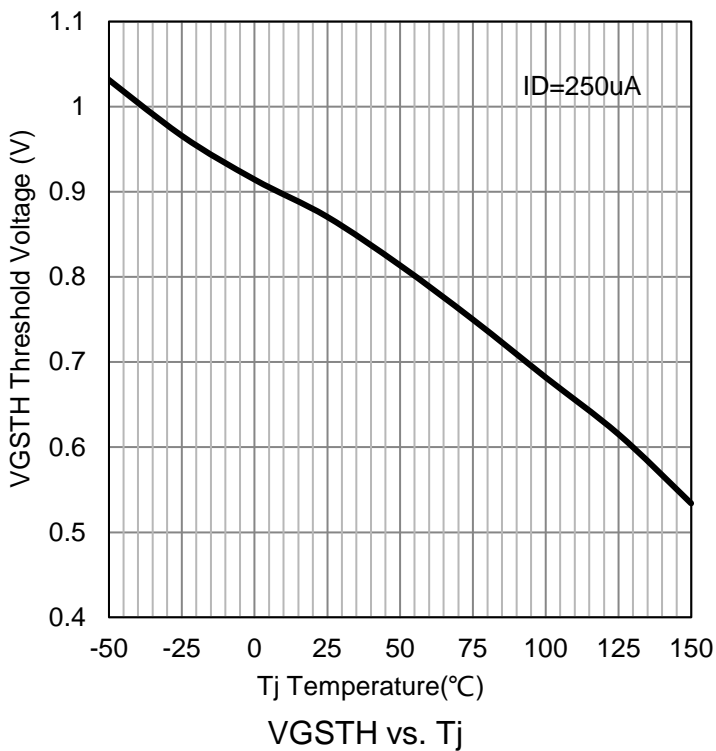
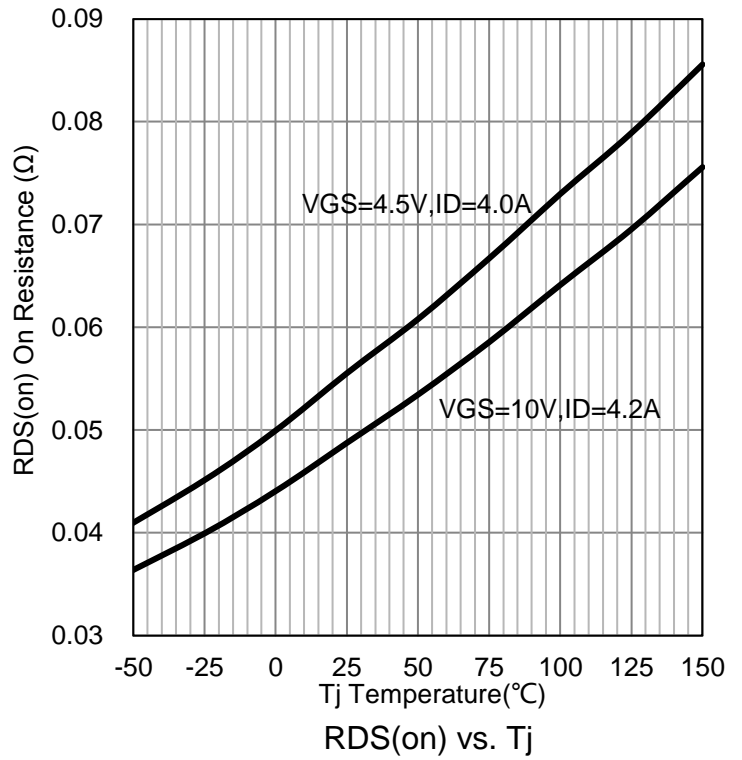
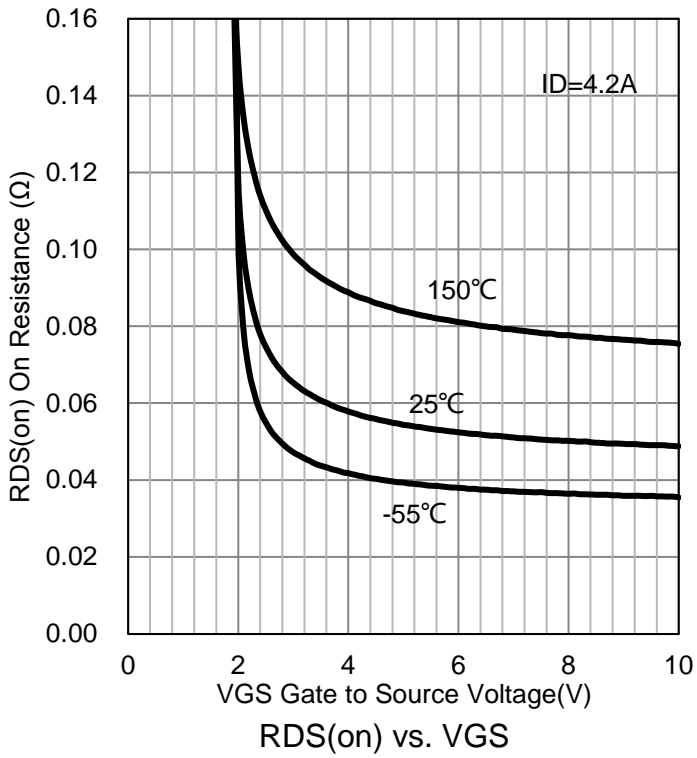

8. OUTLINE AND DIMENSIONS

SOT23LC

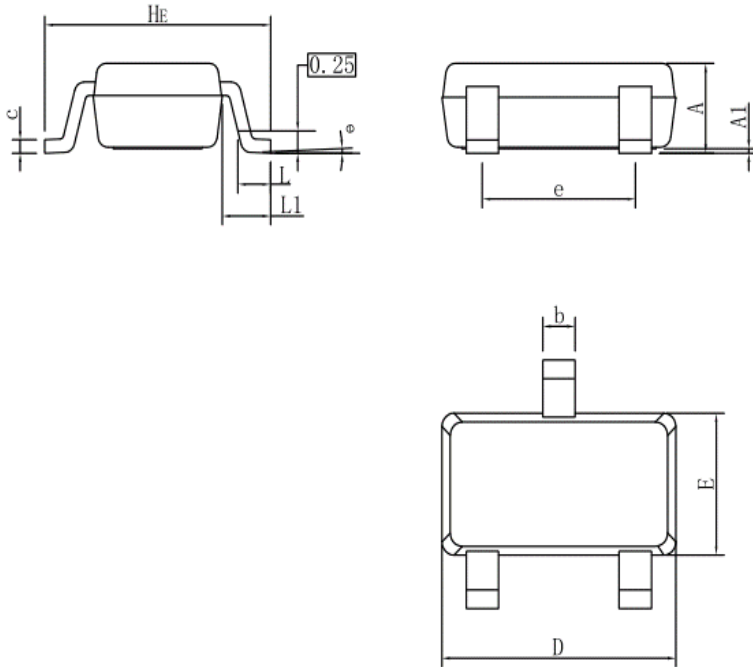

SOT23-LC			
DIM	MIN	NOR	MAX
A	0.90	1.00	1.10
A1	0.01	0.06	0.10
b	0.30	0.40	0.50
c	0.10	0.17	0.20
D	2.80	2.90	3.00
E	1.50	1.60	1.70
e	1.80	1.90	2.00
L	0.20	0.40	0.60
L1	0.60REF		
HE	2.60	2.80	3.00
θ	0°	-	10°
All Dimensions in mm			

GENERAL NOTES

1. Top package surface finish Ra0.4±0.2um
2. Bottom package surface finish Ra0.7±0.2um
3. Side package surface finish Ra0.4±0.2um

9. SOLDERING FOOTPRINT

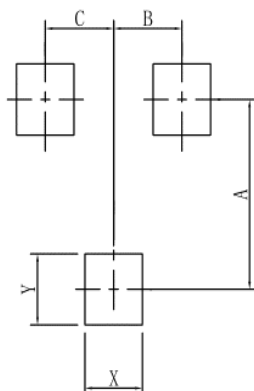

SOT23-LC	
DIM	(mm)
X	0.80
Y	0.90
A	2.40
B	0.95
C	0.95

单击下面可查看定价，库存，交付和生命周期等信息

[>>LRC\(乐山无线电\)](#)