

LBC846BDW1T1G

S-LBC846BDW1T1G

Dual General Purpose Transistors
NPN Duals

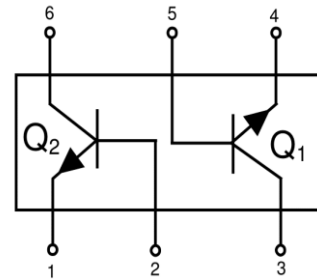
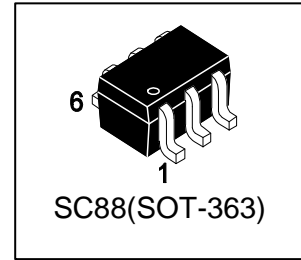

1. FEATURES

- We declare that the material of product compliance with RoHS requirements and Halogen Free.
- S- prefix for automotive and other applications requiring unique site and control change requirements; AEC-Q101 qualified and PPAP capable.

2. DEVICE MARKING AND RESISTOR VALUES

Device	Marking	Shipping
LBC846BDW1T1G	1B	3000/Tape&Reel
LBC846BDW1T3G	1B	10000/Tape&Reel

3. MAXIMUM RATINGS(Ta = 25°C)

Parameter	Symbol	Limits	Unit
Collector–Emitter Voltage	V _{CEO}	65	V
Collector–Base Voltage	V _{CBO}	80	V
Emitter–Base Voltage	V _{EBO}	6	V
Collector Current — Continuous	I _C	100	mA

4. THERMAL CHARACTERISTICS

Parameter	Symbol	Limits	Unit
Total Device Dissipation, Per Device	PD	380 250	mW mW
FR– 5 Board(Note 1) @ TA = 25°C Derate above 25°C		3	mW/°C
Thermal Resistance, Junction–to–Ambient	R _{θJA}	328	°C/W
Junction and Storage temperature	T _J , T _{stg}	–55~+150	°C

1. FR–5 = 1.0 x 0.75 x 0.062 in.

5. ELECTRICAL CHARACTERISTICS (Ta= 25°C)

OFF CHARACTERISTICS

Characteristic	Symbol	Min.	Typ.	Max.	Unit
Collector–Emitter Breakdown Voltage (IC = 10 mA)	VBR(CEO)	65	-	-	V
Collector–Emitter Breakdown Voltage (IC = 10 μA, VEB = 0)	VBR(CES)	80	-	-	V
Collector–Base Breakdown Voltage (IC = 10 μA)	VBR(CBO)	80	-	-	V
Emitter–Base Breakdown Voltage (IE = 1.0 μA)	VBR(EBO)	6	-	-	V
Collector-Base Cutoff Current (VCB = 30 V)	ICBO	-	-	15	nA
(VCB = 30 V, TA = 150°C)		-	-	5	μA

ON CHARACTERISTICS

DC Current Gain (IC = 2.0 mA, VCE = 5 V)	HFE	200	290	450	
Collector–Emitter Saturation Voltage (IC = 10 mA, IB = 0.5 mA)	VCE(sat)	-	-	0.25	V
(IC = 100 mA, IB = 5.0 mA)		-	-	0.6	
Base–Emitter Saturation Voltage (IC = 10 mA, IB = 0.5 mA)	VBE(sat)	-	0.7	-	V
(IC = 100 mA, IB = 5.0 mA)		-	0.9	-	
Base–Emitter Voltage (IC = 2.0 mA, VCE = 5.0 V)	VBE(on)	580	660	700	mV
(IC = 10 mA, VCE = 5.0 V)		-	-	770	
Current–Gain — Bandwidth Product (IC = 10 mA, VCE = 5.0 V, f = 100 MHz)	fT	100	-	-	MHz
Output Capacitance (VCB = 10 V, f = 1.0 MHz)	Cobo	-	-	4.5	pF
Noise Figure (IC= 0.2 mA, VCE=5.0 V, RS=2.0 kΩ, f = 1.0 kHz, BW = 200 Hz)	NF	-	-	10	dB

6. ELECTRICAL CHARACTERISTICS CURVES

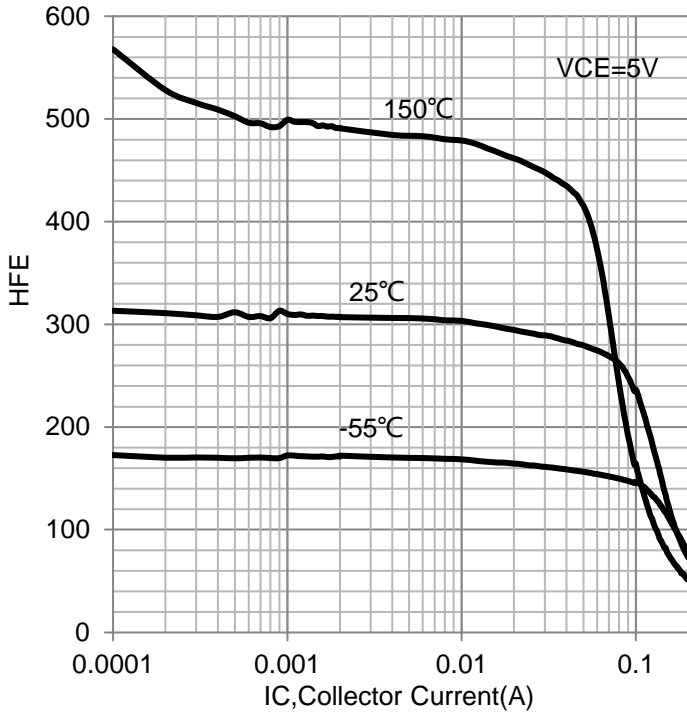

HFE vs. IC

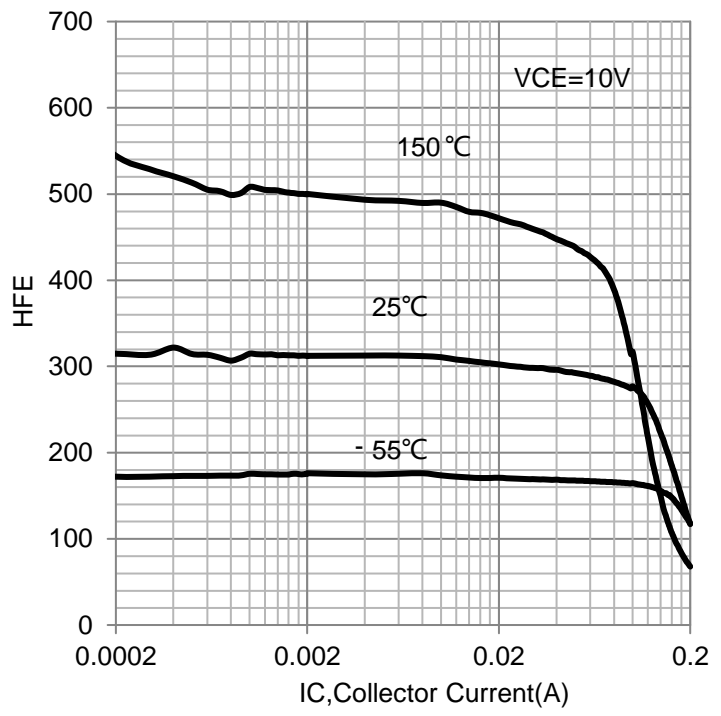

HFE vs. IC (VCE=10V)

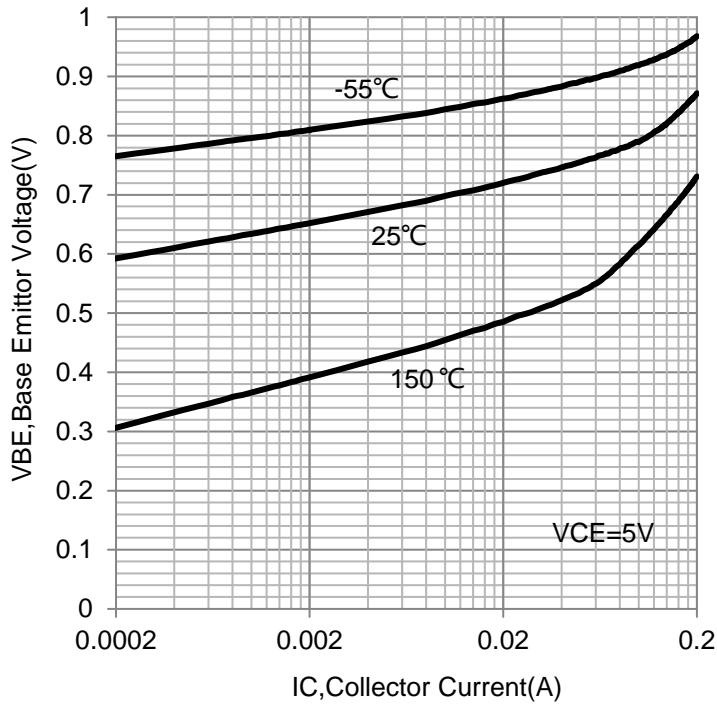

VBE(on) vs. IC

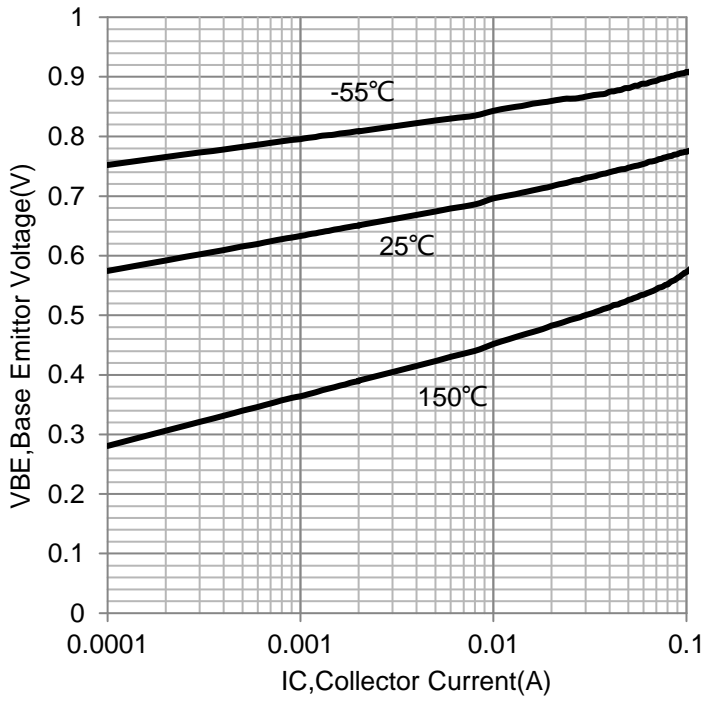

VBE(on) vs. IC

6. ELECTRICAL CHARACTERISTICS CURVES(Con.)

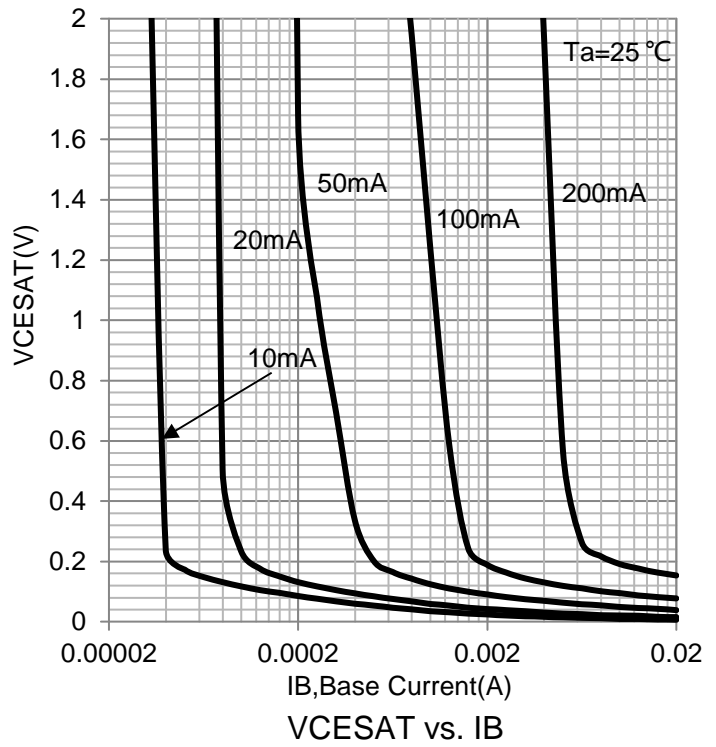
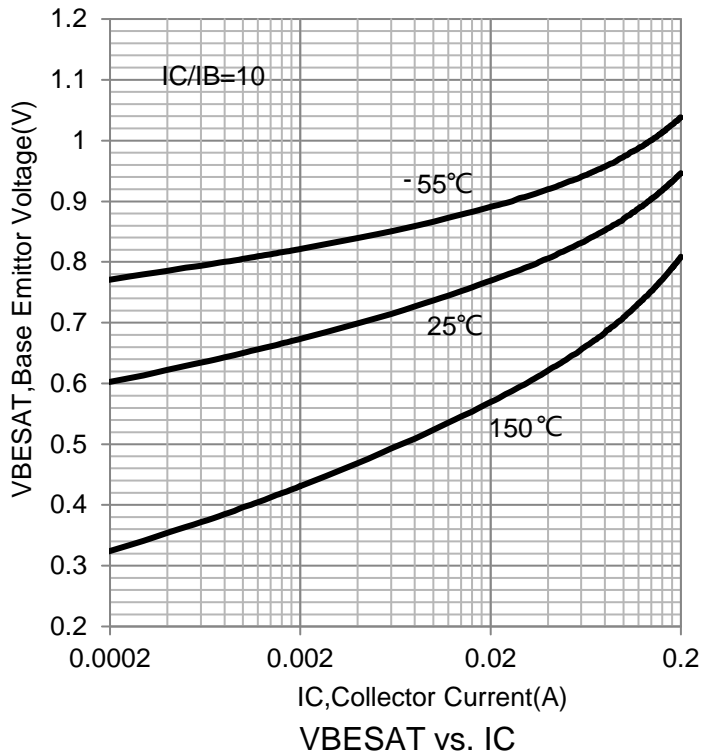

7. OUTLINE AND DIMENSIONS

Notes:

1. DIMENSIONING AND TOLERANCING PER ANSI Y14.5M, 1982.
2. CONTROLLING DIMENSION: MILLIMETERS.
3. MAXIMUM LEAD THICKNESS INCLUDES LEAD FINISH. MINIMUM LEAD THICKNESS IS THE MINIMUM THICKNESS OF BASE MATERIAL.
4. DIMENSIONS D AND E1 DO NOT INCLUDE MOLD FLASH, PROTRUSIONS OR GATE BURRS.

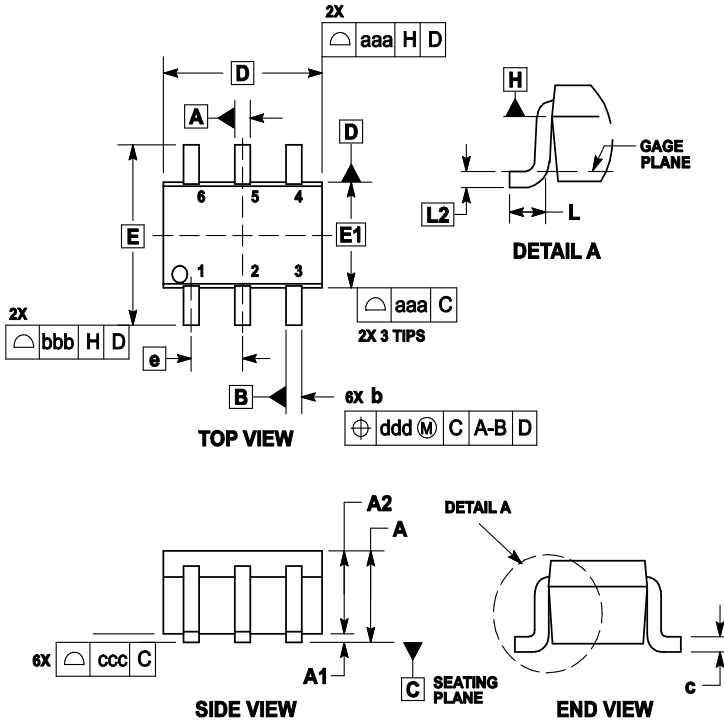

DIM	MILLIMETERS			INCHES		
	MIN	NOM	MAX	MIN	NOM	MAX
A	---	---	1.10	---	---	0.043
A1	0.00	---	0.10	0	---	0.004
A2	0.70	0.90	1.00	0.027	0.035	0.039
b	0.15	0.20	0.25	0.006	0.008	0.01
C	0.08	0.15	0.22	0.003	0.006	0.009
D	1.80	2.00	2.20	0.07	0.078	0.086
E	2.00	2.10	2.20	0.078	0.082	0.086
E1	1.15	1.25	1.35	0.045	0.049	0.053
e	0.65 BSC			0.026 BSC		
L	0.26	0.36	0.46	0.010	0.014	0.018
L2	0.15 BSC			0.006 BSC		
aaa	0.15			0.01		
bbb	0.30			0.01		
ccc	0.10			0.00		
ddd	0.10			0.00		

8. SOLDERING FOOTPRINT

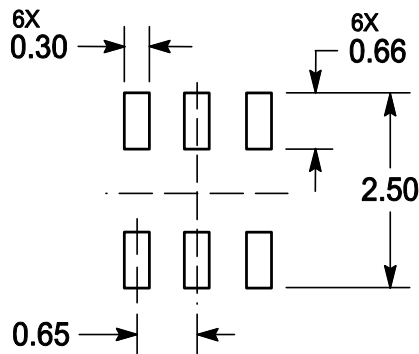

单击下面可查看定价，库存，交付和生命周期等信息

[>>LRC\(乐山无线电\)](#)