

LBC807-25LT1G

S-LBC807-25LT1G

General Purpose Transistors PNP Silicon

1. FEATURES

- We declare that the material of product compliance with RoHS requirements and Halogen Free.
- S- prefix for automotive and other applications requiring unique site and control change requirements; AEC-Q101 qualified and PPAP capable.
- Collector current capability $I_C = -500$ mA.
- Collector-emitter voltage $V_{CEO} (\text{max}) = -45$ V.
- General purpose switching and amplification.

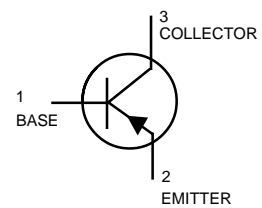
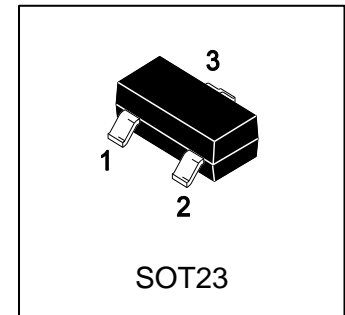

2. DEVICE MARKING AND ORDERING INFORMATION

Device	Marking	Shipping
LBC807-25LT1G	5B1	3000/Tape&Reel
LBC807-25LT3G	5B1	10000/Tape&Reel

3. MAXIMUM RATINGS($T_a = 25^\circ\text{C}$)

Parameter	Symbol	Limits	Unit
Collector-Emitter Voltage	V_{CEO}	-45	V
Collector-Base voltage	V_{CBO}	-50	V
Emitter-Base Voltage	V_{EBO}	-5	V
Collector current	I_C	-500	mA
Peak Collector Current	I_{CM}	-800	mA

4. THERMAL CHARACTERISTICS

Parameter	Symbol	Limits	Unit
Total Device Dissipation, FR-5 Board (Note 1) @ $T_A = 25^\circ\text{C}$ Derate above 25°C	PD	225 1.8	mW mW/ $^\circ\text{C}$
Thermal Resistance, Junction-to-Ambient	$R_{\theta JA}$	556	$^\circ\text{C}/\text{W}$
Total Device Dissipation, Alumina Substrate, (Note 2) @ $T_A = 25^\circ\text{C}$ Derate above 25°C	PD	300 2.4	mW mW/ $^\circ\text{C}$
Thermal Resistance, Junction-to-Ambient	$R_{\theta JA}$	417	$^\circ\text{C}/\text{W}$
Junction and Storage temperature	T_J, T_{stg}	-55~+150	$^\circ\text{C}$

1. FR-5 = 1.0×0.75×0.062 in.

2. Alumina = 0.4 x 0.3 x 0.024 in. 99.5% alumina.

5. ELECTRICAL CHARACTERISTICS (Ta= 25°C)

OFF CHARACTERISTICS

Characteristic	Symbol	Min.	Typ.	Max.	Unit
Collector-Emitter Breakdown Voltage (IC = -10mA)	V(BR)CEO	-45	-	-	V
Collector-Base Breakdown voltage (IC = -10μA)	V(BR)CBO	-50	-	-	V
Emitter-Base Breakdown Voltage (IE = -1μA)	V(BR)EBO	-5	-	-	V
Collector Cutoff Current (VCB = -20 V) (VCB = -20 V, TJ = 150°C)	ICBO	-	-	-100 -5	nA μA
Collector-Emitter Cutoff Current (VCE=-45V, IB=0)	ICEO	-	-	-100	nA
Emitter CutOff Current (VEB=-7V, IC=0)	IEBO	-	-	-100	nA

ON CHARACTERISTICS

DC Current Gain (IC = -100 mA, VCE = -1.0 V) (IC = -500 mA, VCE = -1.0 V)	HFE	160 40	- -	400 -	
Collector-Emitter Saturation Voltage (IC = -500 mA, IB = -50 mA)	VCE(sat)	-	-	-0.7	V
Base-Emitter On Voltage (IC = -500 mA, VCE = -1.0 V)	VBE(on)	-	-	-1.2	V

SMALL-SIGNAL CHARACTERISTICS

Current-Gain — Bandwidth Product (IC = -10 mA, VCE = -5.0 V, f = 100 MHz)	fT	100	-	-	MHz
Output Capacitance (VCB = -10 V, f = 1.0 MHz)	Cobo	-	10	-	pF
Input Capacitance (VEB=0.5V, IC = 0, f=1.0MHz)	Cibo	-	34.5	-	pF

6.ELECTRICAL CHARACTERISTICS CURVES

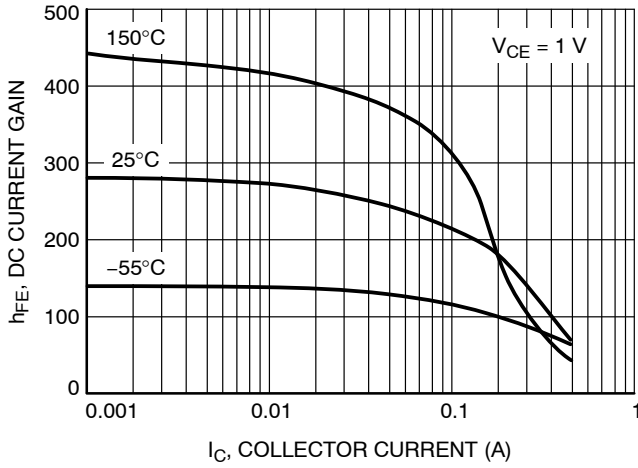

Figure 1. DC Current Gain vs. Collector Current

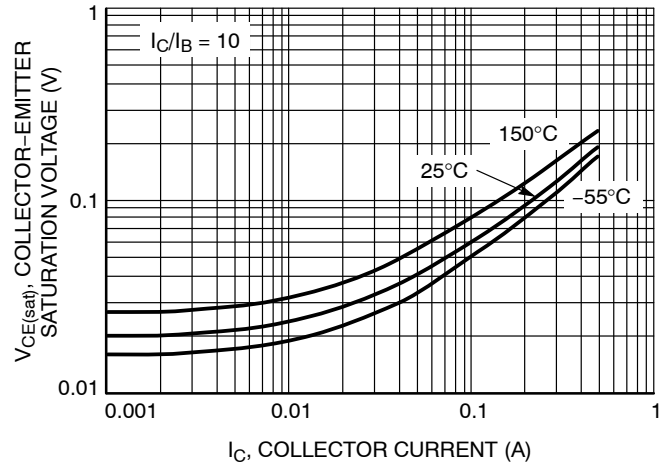

Figure 2. Collector Emitter Saturation Voltage vs. Collector Current

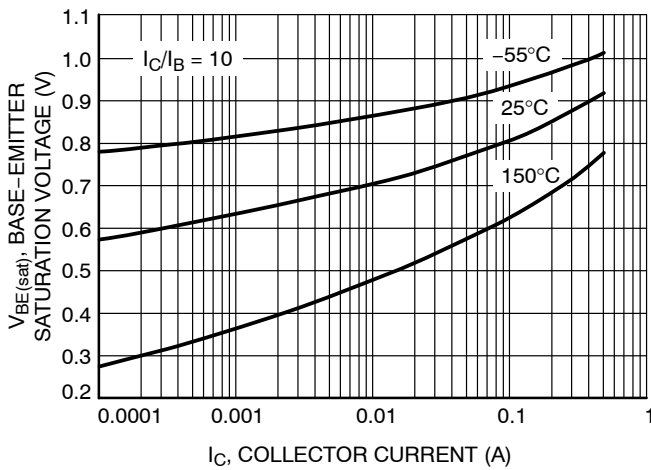

Figure 3. Base Emitter Saturation Voltage vs. Collector Current

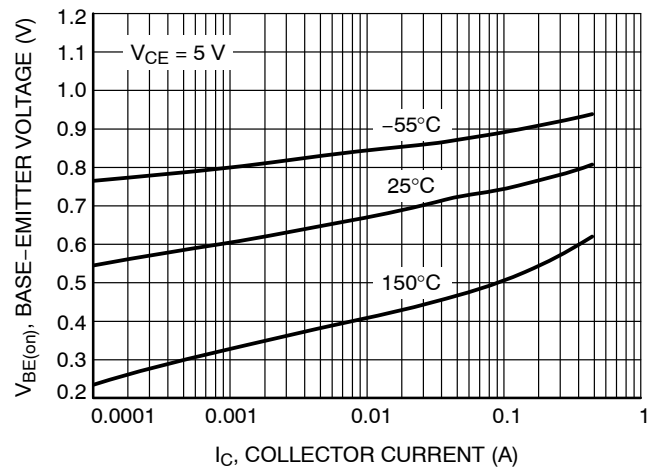

Figure 4. Base Emitter Voltage vs. Collector Current

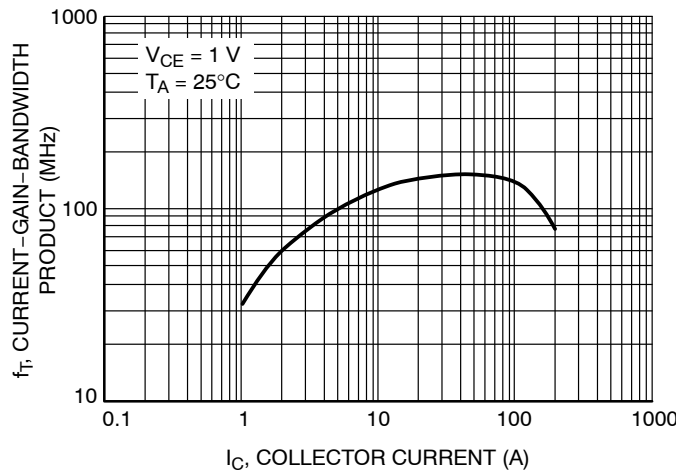

Figure 5. Current Gain Bandwidth Product vs. Collector Current

6.ELECTRICAL CHARACTERISTICS CURVES(Con.)

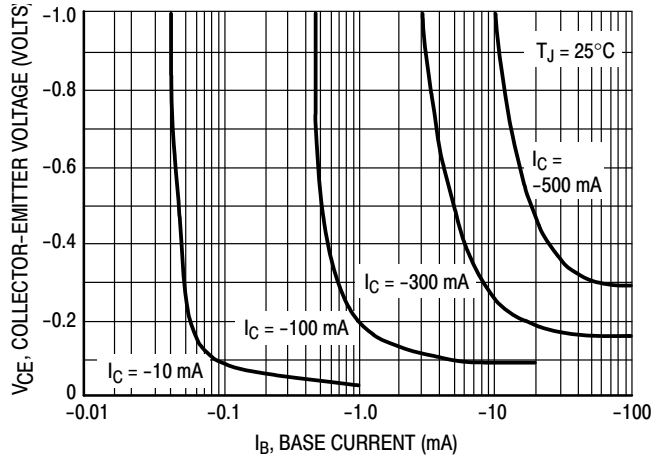

Figure 6. Saturation Region

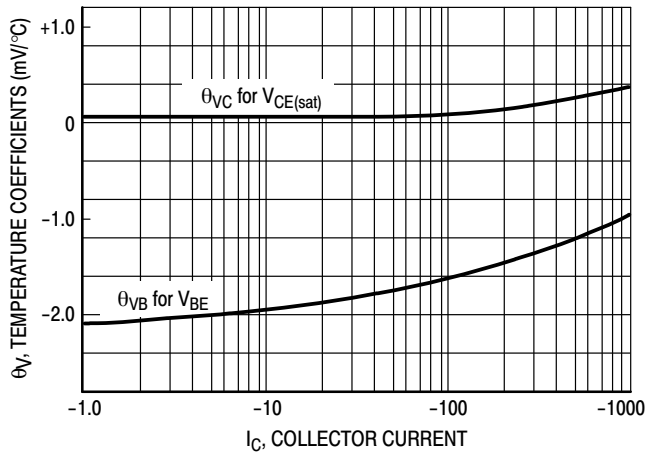

Figure 7. Temperature Coefficients

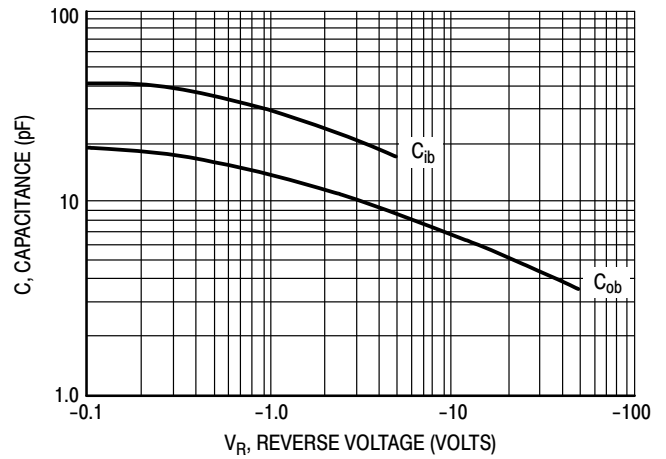
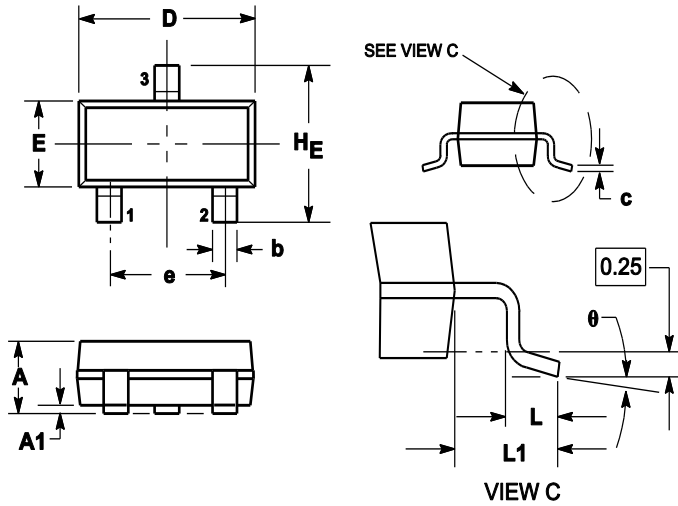

Figure 8. Capacitances

7. OUTLINE AND DIMENSIONS

Notes:

1. DIMENSIONING AND TOLERANCING PER ANSI Y14.5M, 1982.
2. CONTROLLING DIMENSION: MILLIMETERS.
3. MAXIMUM LEAD THICKNESS INCLUDES LEAD FINISH. MINIMUM LEAD THICKNESS IS THE MINIMUM THICKNESS OF BASE MATERIAL.
4. DIMENSIONS D AND E DO NOT INCLUDE MOLD FLASH, PROTRUSIONS OR GATE BURRS.



DIM	MILLIMETERS			INCHES		
	MIN	NOM	MAX	MIN	NOM	MAX
A	0.89	1	1.11	0.035	0.04	0.044
A1	0.01	0.06	0.1	0.001	0.002	0.004
b	0.37	0.44	0.5	0.015	0.018	0.02
c	0.09	0.13	0.18	0.003	0.005	0.007
D	2.80	2.9	3.04	0.11	0.114	0.12
E	1.20	1.3	1.4	0.047	0.051	0.055
e	1.78	1.9	2.04	0.07	0.075	0.081
L	0.10	0.2	0.3	0.004	0.008	0.012
L1	0.35	0.54	0.69	0.014	0.021	0.029
HE	2.10	2.4	2.64	0.083	0.094	0.104
θ	0°	---	10°	0°	---	10°

8. SOLDERING FOOTPRINT

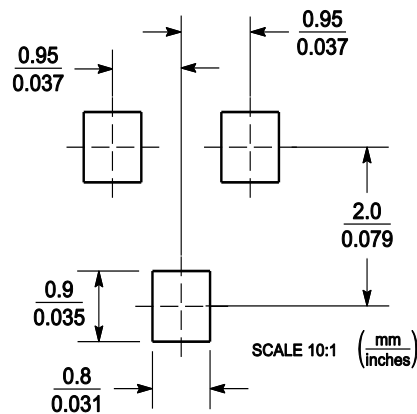

DISCLAIMER

- Curve guarantee in the specification. The curve of test items with electric parameter is used as quality guarantee. The curve of test items without electric parameter is used as reference only.
- Before you use our Products for new Project, you are requested to carefully read this document and fully understand its contents. LRC shall not be in any way responsible or liable for failure, malfunction or accident arising from the use of any LRC's Products against warning, caution or note contained in this document.
- All information contained in this document is current as of the issuing date and subject to change without any prior notice. Before purchasing or using LRC's Products, please confirm the latest information with a LRC sales representative.

单击下面可查看定价，库存，交付和生命周期等信息

[>>LRC\(乐山无线电\)](#)