

LBC817-25LT1G

S-LBC817-25LT1G

General Purpose Transistors NPN Silicon

1. FEATURES

- We declare that the material of product compliance with RoHS requirements and Halogen Free.
- S- prefix for automotive and other applications requiring unique site and control change requirements; AEC-Q101 qualified and PPAP capable.

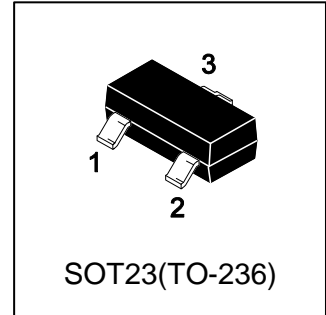

2. DEVICE MARKING AND ORDERING INFORMATION

Device	Marking	Shipping
LBC817-25LT1G	6B	3000/Tape&Reel
LBC817-25LT3G	6B	10000/Tape&Reel

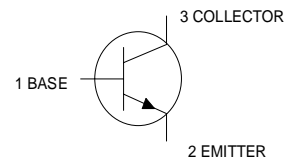

3. MAXIMUM RATINGS(Ta = 25°C)

Parameter	Symbol	Limits	Unit
Collector–Emitter Voltage	V _{CEO}	45	V
Collector–Base Voltage	V _{CBO}	50	V
Emitter–Base Voltage	V _{EBO}	5	V
Collector Current — Continuous	I _C	500	mA
Peak Collector Current	I _{CM}	800	mA

4. THERMAL CHARACTERISTICS

Parameter	Symbol	Limits	Unit
Total Device Dissipation, FR-5 Board (Note 1) @ TA = 25°C Derate above 25°C	PD	225 1.8	mW mW/°C
Thermal Resistance, Junction–to–Ambient	R _{θJA}	556	°C/W
Total Device Dissipation, Alumina Substrate (Note 2) @ TA = 25°C Derate above 25°C	PD	300 2.4	mW mW/°C
Thermal Resistance, Junction–to–Ambient	R _{θJA}	417	°C/W
Junction and Storage temperature	T _J , T _{stg}	-55~+150	°C

1. FR-5 = 1.0×0.75×0.062 in.

2. Alumina = 0.4 x 0.3 x 0.024 in. 99.5% alumina.

5. ELECTRICAL CHARACTERISTICS (Ta= 25°C)

Characteristic	Symbol	Min.	Typ.	Max.	Unit
Collector–Emitter Breakdown Voltage (IC = 10 mA)	VBR(CEO)	45	-	-	V
Collector–Base Breakdown Voltage (IC = 10 μA)	VBR(CBO)	50	-	-	V
Emitter–Base Breakdown Voltage (IE = 1.0 μA)	VBR(EBO)	5	-	-	V
Collector Cutoff Current (VCB = 20 V) (VCB = 20 V, TA=150°C)	ICBO	- -	- -	100 5	nA μA
DC Current Gain (IC = 100 mA, VCE = 1.0 V) (IC = 500 mA, VCE = 1.0 V)	HFE	160 40	- -	400 -	
Collector–Emitter Saturation Voltage (IC = 500 mA, IB = 50 mA)	VCE(sat)	-	-	0.7	V
Base–Emitter on Voltage (IC = 500 mA, VCE = 1.0 V)	VBE(on)	-	-	1.2	V
Current–Gain — Bandwidth Product (IC = 10mA, VCE= 5V, f = 100MHz)	fT	100	-	-	MHz
Output Capacitance (VCB = 10 V, IE = 0, f = 1.0 MHz)	Cob	-	10	-	pF

6.ELECTRICAL CHARACTERISTICS CURVE

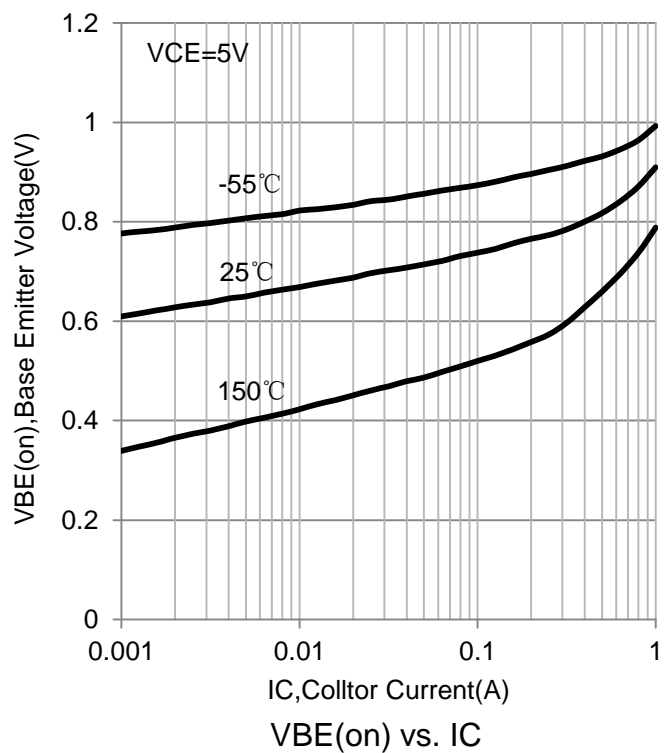
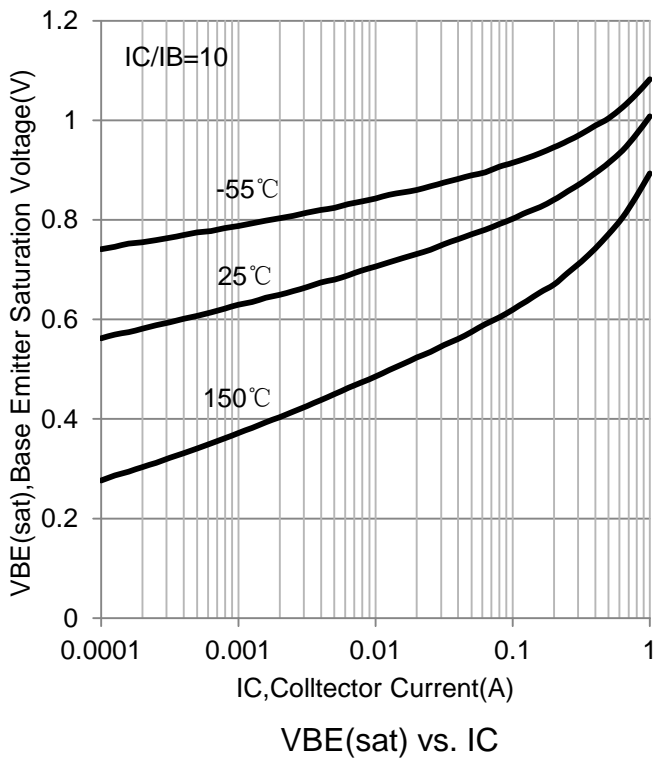
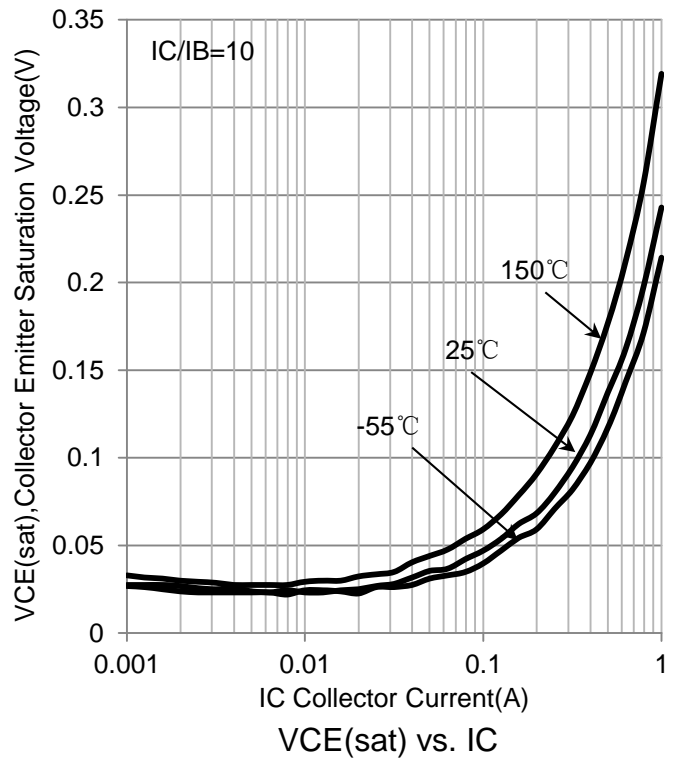
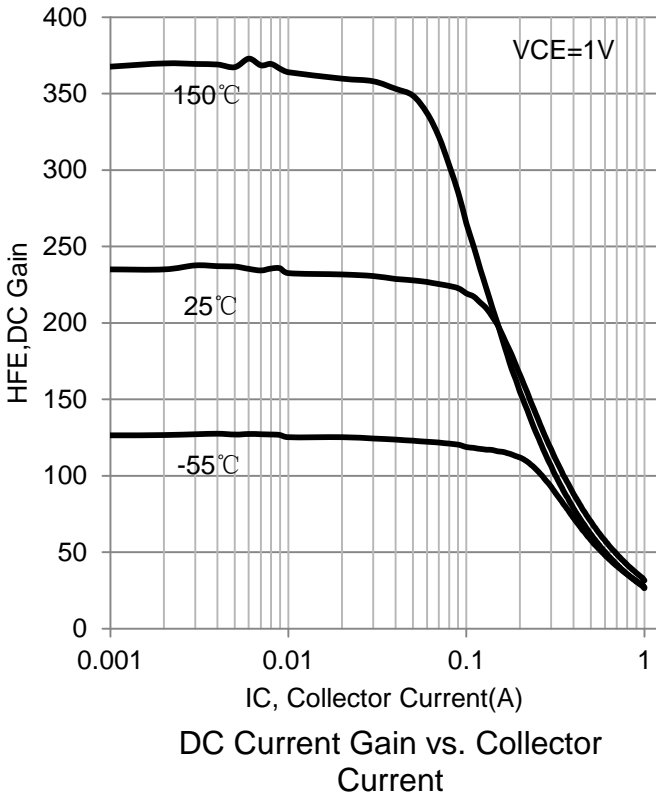

6.ELECTRICAL CHARACTERISTICS CURVES(Con.)

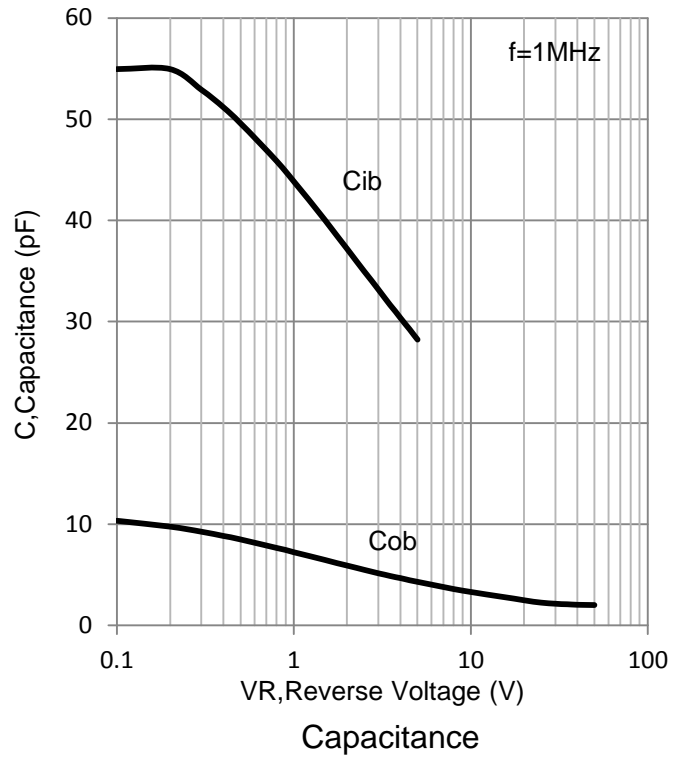
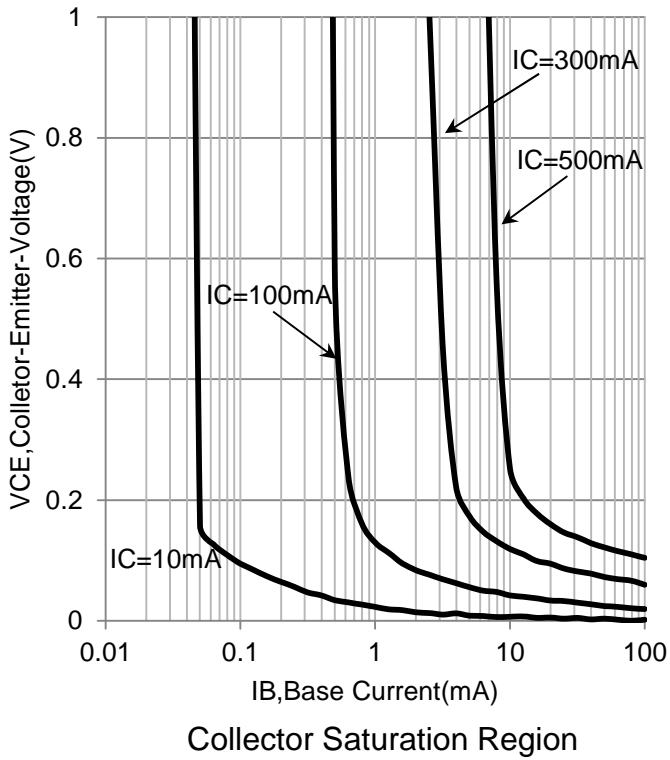

7. OUTLINE AND DIMENSIONS

Notes:

1. DIMENSIONING AND TOLERANCING PER ANSI Y14.5M, 1982.
2. CONTROLLING DIMENSION: MILLIMETERS.
3. MAXIMUM LEAD THICKNESS INCLUDES LEAD FINISH. MINIMUM LEAD THICKNESS IS THE MINIMUM THICKNESS OF BASE MATERIAL.
4. DIMENSIONS D AND E DO NOT INCLUDE MOLD FLASH, PROTRUSIONS OR GATE BURRS.

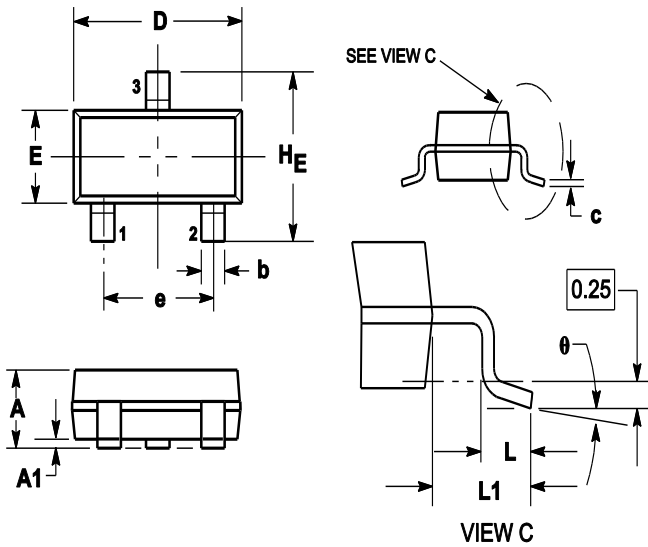

DIM	MILLIMETERS			INCHES		
	MIN	NOM	MAX	MIN	NOM	MAX
A	0.89	1	1.11	0.035	0.04	0.044
A1	0.01	0.06	0.1	0.001	0.002	0.004
b	0.37	0.44	0.5	0.015	0.018	0.02
c	0.09	0.13	0.18	0.003	0.005	0.007
D	2.80	2.9	3.04	0.11	0.114	0.12
E	1.20	1.3	1.4	0.047	0.051	0.055
e	1.78	1.9	2.04	0.07	0.075	0.081
L	0.10	0.2	0.3	0.004	0.008	0.012
L1	0.35	0.54	0.69	0.014	0.021	0.029
HE	2.10	2.4	2.64	0.083	0.094	0.104
θ	0°	---	10°	0°	---	10°

8. SOLDERING FOOTPRINT

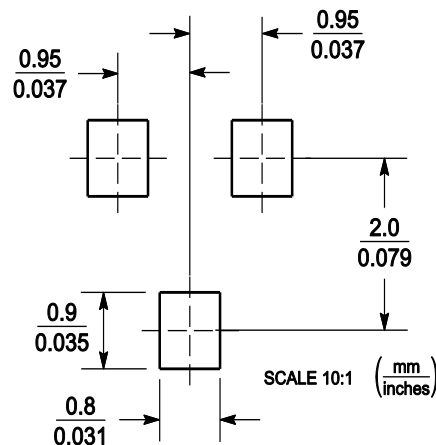

单击下面可查看定价，库存，交付和生命周期等信息

[>>LRC\(乐山无线电\)](#)