

S-SOD4001-SH thru S-SOD4005-SH

Surface Mount Glass Passivated Junction Rectifiers
Reverse Voltage 50 to 600V Forward Current 1.0A

FEATURES

- * Plastic package has Underwriters Laboratory Flammability Classification 94V-0
- * High temperature metallurgically bonded construction
- * Cavity-free glass passivated junction
- * Capable of meeting environmental standards of MIL-S-19500
- * 1.0 A operation at TC=100°C with no thermal runaway
- * Typical IR less than 1.0μA
- * High temperature soldering guaranteed: 260°C/10 seconds
- * S- Prefix for Automotive and Other Applications Requiring Unique Site and Control Change Requirements; AEC-Q101 Qualified and PPAP Capable.

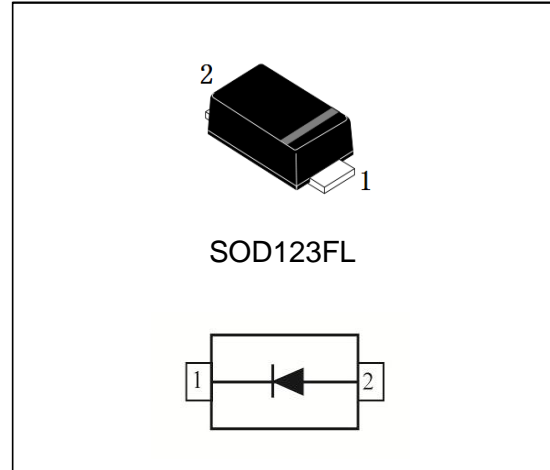

We declare that the material of product is
Halogen free (green epoxy compound)

Mechanical Data

Case: JEDEC SOD123-FL/MINI SMA, molded plastic over glass DIE

Terminals: Tin Plated, solderable per
MIL-STD-750, Method 2026

Polarity: Color band denotes cathode end

Mounting Position: Any

Weight: 0.0155 g

Handling precaution: None

Electrical Characteristic

1. Maximum & Thermal Characteristics Ratings at 25°C ambient temperature unless otherwise specified.

Parameter Symbol	symbol	S-SOD 4001-SH	S-SOD 4002-SH	S-SOD 4003-SH	S-SOD 4004-SH	S-SOD 4005-SH			Unit
Device marking code		A1	A2	A3	A4	A5			
Maximum repetitive peak reverse voltage	V_{RRM}	50	100	200	400	600			V
Maximum RMS voltage	V_{RMS}	35	70	140	280	420			V
Maximum DC blocking voltage	V_{DC}	50	100	200	400	600			V
Maximum average forward rectified current lead length at $T_C = 100^\circ\text{C}$ (Note 1)	$I_{F(AV)}$	1.0							A
Peak forward surge current 8.3ms single half sine-wave superimposed on rated load (JEDEC Method)	I_{FSM}	30							A
reverse surger current(20ms)	I_{RSM}	18							mA
Typical thermal resistance (Note 1)	$R_{\theta JA}$	170							°C/W
Operating junction temperature range	T_J	-55 to +150							°C
storage temperature range	T_{STG}	-55 to +150							°C

Electrical Characteristics Ratings at 25°C ambient temperature unless otherwise specified.

Parameter Symbol	symbol	S-SOD 4001-SH	S-SOD 4002-SH	S-SOD 4003-SH	S-SOD 4004-SH	S-SOD 4005-SH			Unit
Maximum instantaneous forward voltage at 1.0A	V_F	1.1							V
Maximum DC reverse current $T_J = 25^\circ\text{C}$ at rated DC blocking voltage $T_J = 125^\circ\text{C}$	I_R	5.0 50							μA
Typical junction capacitance at 4.0V, 1MHz	C_J	15.0							PF

NOTES:

1. 8.0mm² (.013mm thick) land areas

S-SOD4001-SH thru S-SOD4005-SH

2. Ratings and Characteristic Curves (TA = 25°C unless otherwise noted)

Fig. 1 - Forward Current Derating Curve

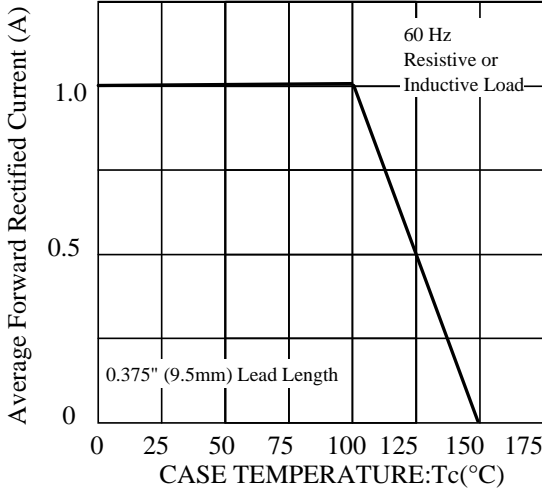

Fig. 2 - Maximum Non-repetitive Peak Forward Surge Current

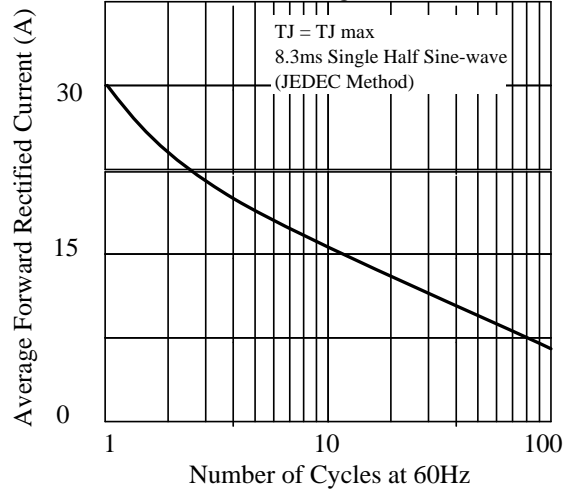

Fig 3. - Typical Instantaneous Forward Characteristics

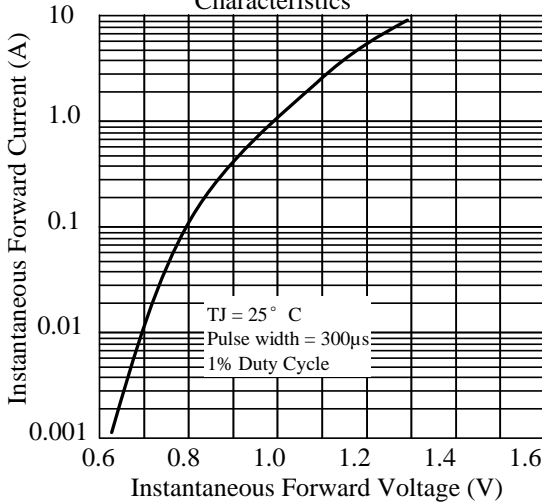

Fig 4. - Typical Reverse Characteristics

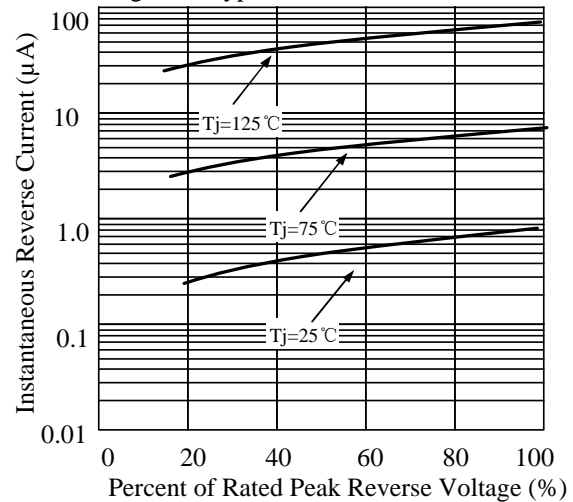

Fig 5. - typical transient thermal impedance

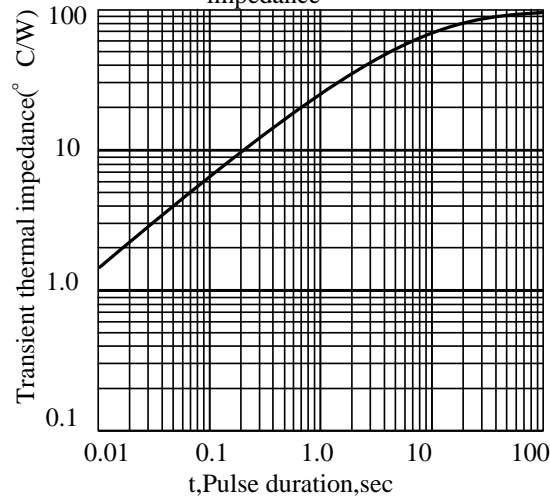
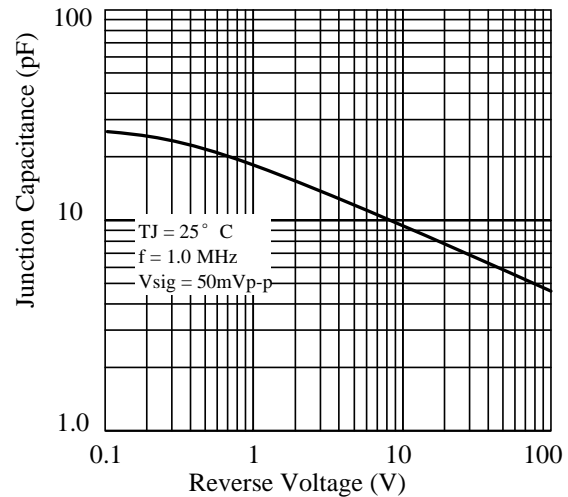
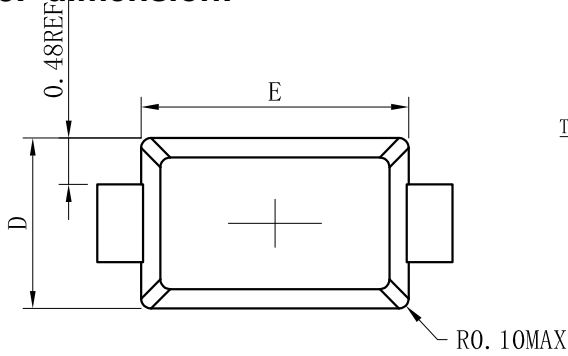

Fig 6. - Typical Junction Capacitance



S-SOD4001-SH thru S-SOD4005-SH

3. dimension:



TOP VIEW

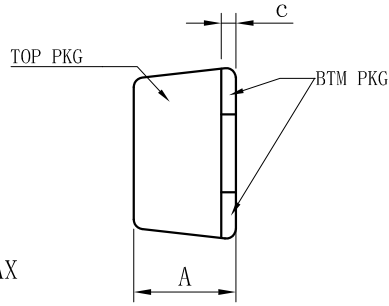

SIDE VIEW

SOD123FL			
DIM	MIN	NOR	MAX
A	0.90	1.05	1.15
b	0.75	0.80	0.95
L	0.50	0.80	1.10
E	2.60	2.75	2.90
D	1.60	1.75	1.90
HE	3.50	3.65	3.80
c	0.12	0.17	0.22
L1	0.25	0.45	0.65
All Dimensions in mm			

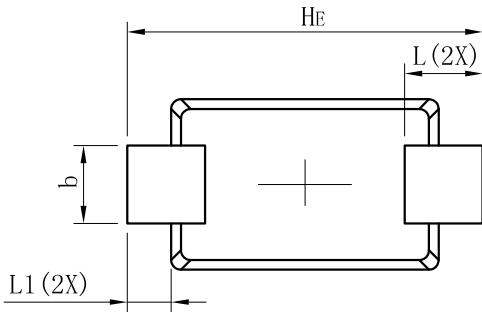

BOTTOM VIEW

GENERAL NOTES

1. Top package surface finish $Ra0.4 \pm 0.2 \mu m$
2. Bottom package surface finish $Ra0.7 \pm 0.2 \mu m$
3. Side package surface finish $Ra0.4 \pm 0.2 \mu m$

Suggested solder pad layout

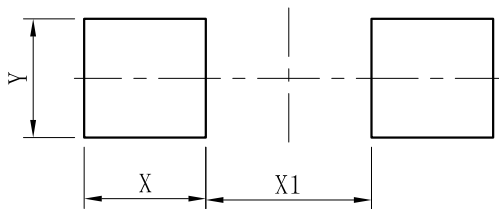

DIM	(mm)
X	1.20
Y	1.10
X1	2.00

S-SOD4001-SH thru S-SOD4005-SH

4. Suggested thermal profile for soldering process

1. Storage environment : Temperature=5~40°C Humidity=55±25%
2. Reflow soldering of surface-mount device

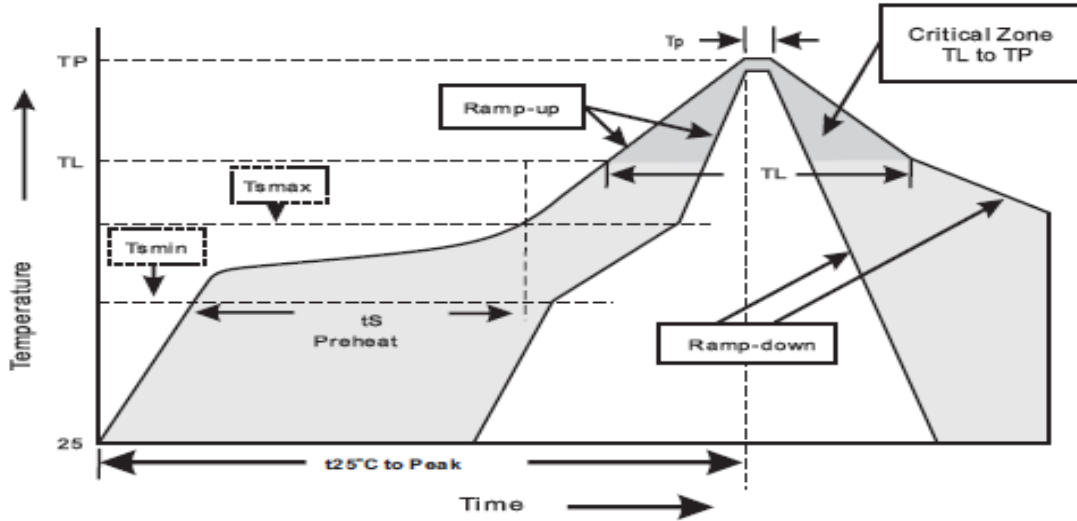

3. Reflow soldering

Profile Feature	Soldering Condition
Average ramp-up rate(T _L to T _P)	<3°C/sec
Preheat	
- Temperature Min(T _{smin})	150°C
- Temperature Max(T _{smax})	200°C
- Time(min to max)(t _s)	60~120sec
T _{smax} to T _L	
- Ramp-up Rate	<3sec
Time maintained above:	
- Temperature (T _L)	217°C
- Time(t _L)	60-260sec
Peak Temperature(T _P)	255 -0/+5°C
Time within 5°C of actual Peak Temperature(T _P)	10~30sec
Ramp-down Rate	<6°C/sec
Time 25°C to Peak Temperature	<6minutes

S-SOD4001-SH thru S-SOD4005-SH

5.High reliability test capabilities

TEST ITEMS	CONDITION	DURATION	SAMPLE SIZE	DECISION	
				ACC	REJ
Steady-State Operation Life (SSOL)	IF=100%rateIF VR=100%rateVR T _a =25℃	1000h	77PCS	0	1
Intermittent Operation Life (IOL)	ΔT _j >100℃ Ton=Toff=2min	1000h	77PCS	0	1
High Temperature Reverse Bias (HTRB)	VR=80%rateVR T _j =150℃	1000h	77PCS	0	1
High Humidity High Temperature Reverse Bias (H3TRB)	VR=80%rateVR(VRmax<100V) T _a =85℃ RH=85%	1000h	77PCS	0	1
High Temperature Storage Life (HTSL)	T _a =150℃	1000h	77PCS	0	1
Temperature Cycling (TC)	AIR TO AIR -55℃ / 15MIN 150℃ / 15MIN 25℃ / 20SEC For Transfer	1000 Cycles	77PCS	0	1
Autoclave (AC)	T _a =121℃ 100%RH P=15PSIG	96h	77PCS	0	1
Forward Surge (F.S)	T _a =55℃ IFSM=100%rateIFSM 10ms HALF-SINE	1time	15PCS	0	1
Resistance To Solder Heat (RSH)	260℃±5℃ Reflow Soldering	10 SECS	30PCS	0	1
Solderability (SD)	245℃±5℃	5 SECS	10PCS	0	1

DISCLAIMER

- Before you use our Products, you are requested to carefully read this document and fully understand its contents. LRC shall not be in any way responsible or liable for failure, malfunction or accident arising from the use of any LRC's Products against warning, caution or note contained in this document.
- All information contained in this document is current as of the issuing date and subject to change without any prior notice. Before purchasing or using LRC's Products, please confirm the latest information with a LRC sales representative.



8.1.2 Label position and QA stamp position.(Empty area) 标签张贴位置及QA印章位置。(印章盖在标签空白区)



8.1.3 Ensure direction In the same reel. The same steel coil plate direction, With antistatic bubble to package reel. Refer to the below picture.

同一箱内的卷盘方向一致,用防静电泡沫对卷盘进行包裹。

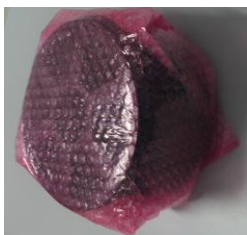

8.1.4 Put in the antistatic packing box after packaged reels. And QA stamp on the box label .

将包装好的卷盘放入防静电纸箱中,并在盒标签上盖章。

Do not copy without written permission from Advanced Power Semiconductor



8.1.5 Product use printing inner box. 产品使用LRC印字内箱。

印字内箱



8.1.6 Inner box size and packing quantity requirement. 内盒尺寸及包装数量要求。

Product Description	Height (H)	Width (W)	Length (L)	Max. Qty
SOD123-FL	185 mm	139 mm	190 mm	1-10Reels
SOD323-HE	185 mm	139 mm	190 mm	1-10Reels
SMA-FL	185 mm	139 mm	190 mm	1-7Reels

8.1.7 With transparent tape sealing. 透明胶带封箱。



8.1.8 Outer box size and packing quantity requirement, 外箱尺寸及包装数量要求。



Proprietary Information

Title: Power Packages Product Packing Specification

功率产品包装规范

Document Number: APS-QA-QS-009

Product Description	Height (H)	Width (W)	Length (L)	Max. Qty
Power Device	410mm	400mm	445mm	12



标签朝上
Logo方向需一致

Do not copy without written permission from Advanced Power Semiconductor

8.2 Standard Products Taping Specification

标准产品编带规范

8.2.1 Tape length of no component

空带长度说明

Taping leader length 引导部分: 440mm±40mm , Tape trailer 尾部: 200mm±40mm

Figure 4

Tape Ends For Finished Goods Reel

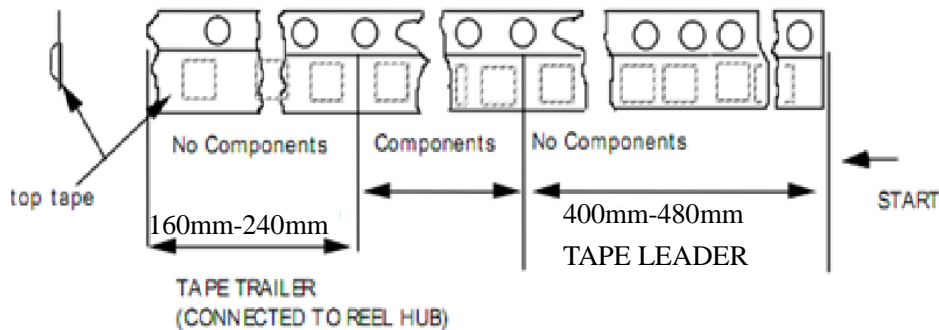

8.2.2 Component packaging orientation: The cathode lead is close to the carrier tape's index hole.

产品放置方向: 印阴极带引脚邻近载带索引孔



8.2.3 Tape enwind orientation

编带缠绕方向要求

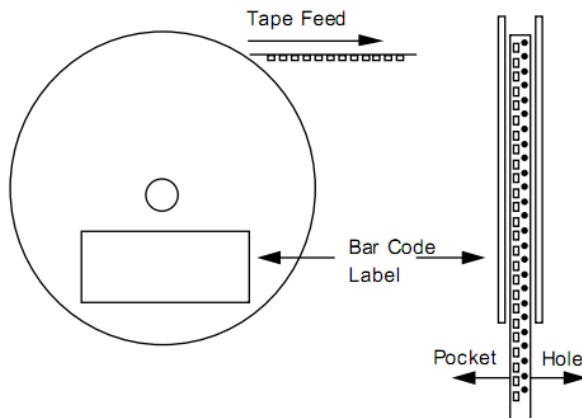

Do not copy without written permission from Advanced Power Semiconductor

单击下面可查看定价，库存，交付和生命周期等信息

[>>LRC\(乐山无线电\)](#)