

S2ABF thru S2MBF

Surface Mount Glass Passivated Junction Rectifiers
Reverse Voltage 50 to 1000V Forward Current 2.0A

FEATURES

- * Plastic package has Underwriters Laboratory Flammability Classification 94V-0
- * High temperature metallurgically bonded construction
- * Cavity-free glass passivated junction
- * Capable of meeting environmental standards of MIL-S-19500
- * 2.0 A operation at $T_c=75^\circ\text{C}$ with no thermal runaway
- * Typical IR less than $1.0\mu\text{A}$
- * High temperature soldering guaranteed: $260^\circ\text{C}/10$ seconds

Mechanical Data

Case: JEDEC SMB-FL, molded plastic over glass Die

Terminals: Plated leads, solderable per MIL-STD-750, Method 2026

Polarity: Color band denotes cathode end

Mounting Position Any

Weight: 0.066 gram

Handling precaution: None

Electrical Characteristic

1. Maximum & Thermal Characteristics Ratings at 25°C ambient temperature unless otherwise specified.

Parameter Symbol	symbol	S2ABF	S2BBF	S2DBF	S2GBF	S2JBF	S2KBF	S2MBF	Unit
Device marking code		S2A	S2B	S2D	S2G	S2J	S2K	S2M	
Maximum repetitive peak reverse voltage	V_{RRM}	50	100	200	400	600	800	1000	V
Maximum RMS voltage	V_{RMS}	35	70	140	280	420	560	700	V
Maximum DC blocking voltage	V_{DC}	50	100	200	400	600	800	1000	V
Maximum average forward rectified current 0.375" (9.5mm) lead length at $T_c = 75^\circ\text{C}$	$I_{F(AV)}$	2.0							A
Peak forward surge current 8.3ms single half sine-wave superimposed on rated load (JEDEC Method)	I_{FSM}	50							A
Typical thermal resistance (Note 1)	$R_{\theta JA}$ $R_{\theta JC}$	135 25							$^\circ\text{C/W}$
Operating junction and storage temperature range	T_J, T_{STG}	-50 to +150							$^\circ\text{C}$

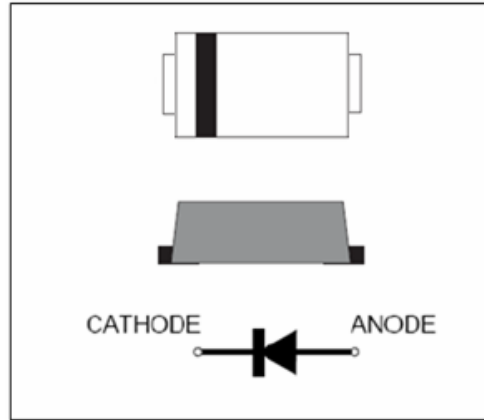

we declare that the material of product is halogen free (green epoxy compound).

Electrical Characteristics Ratings at 25°C ambient temperature unless otherwise specified.

Parameter Symbol	symbol	S2ABF	S2BBF	S2DBF	S2GBF	S2JBF	S2KBF	S2MBF	Unit
Maximum instantaneous forward voltage at 2.0A	V_F	1.1							V
Maximum DC reverse current $T_A = 25^\circ\text{C}$ at rated DC blocking voltage $T_J = 125^\circ\text{C}$	IR	5.0 100							μA
Typical junction capacitance at 4.0V, 1MHz	CJ	30.0							PF

NOTES:

1. 8.0mm^2 (.013mm thick) land areas

S2ABF thru S2MBF

2. Ratings and Characteristic Curves (TA = 25°C unless otherwise noted)

Fig. 1 - Forward Current Derating Curve

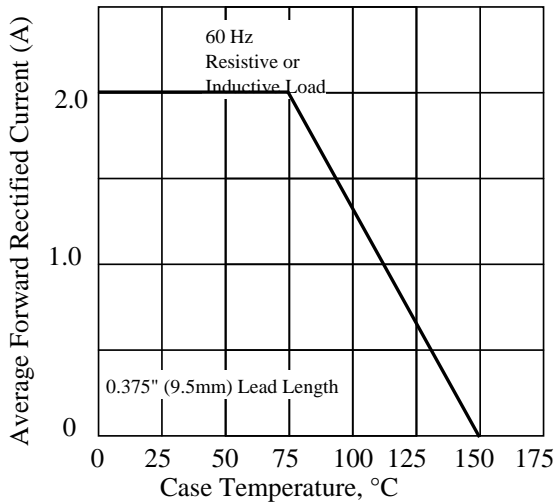

Fig. 2 - Maximum Non-repetitive Peak Forward Surge Current

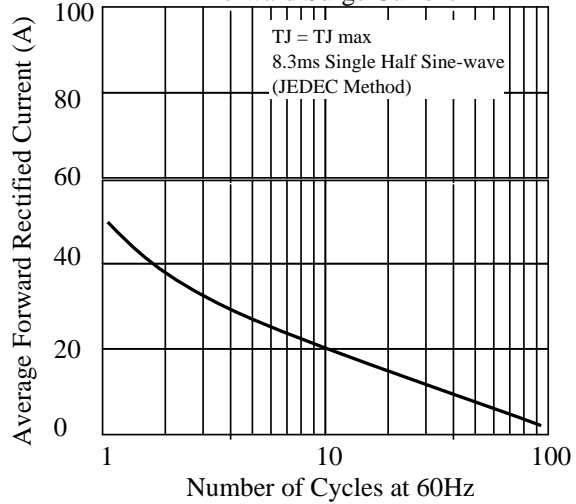

Fig. 3 - Typical Instantaneous Forward Characteristics

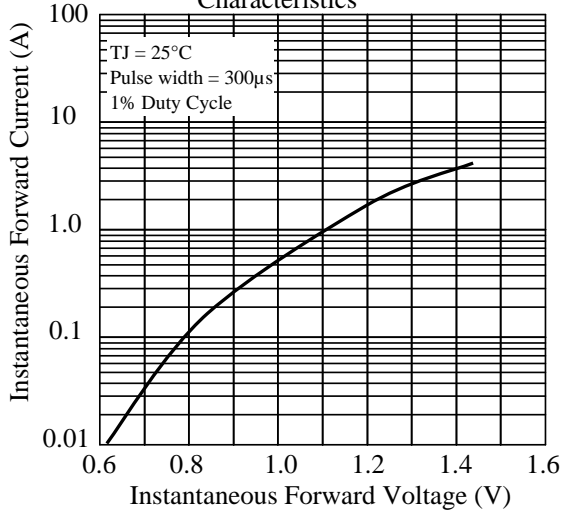

Fig. 4 - Typical Reverse Characteristics

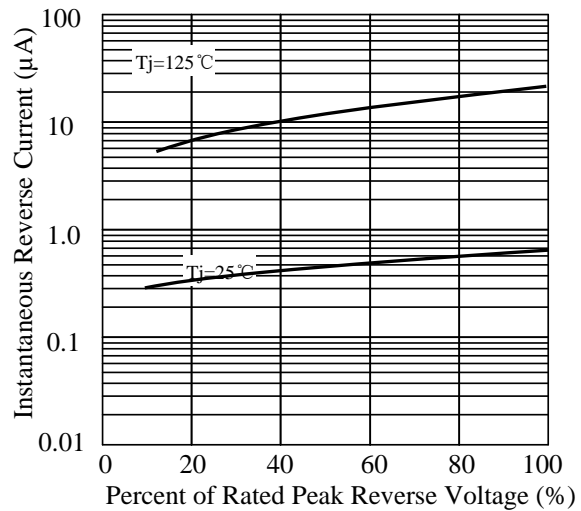

Fig. 5 - typical transient thermal impedance

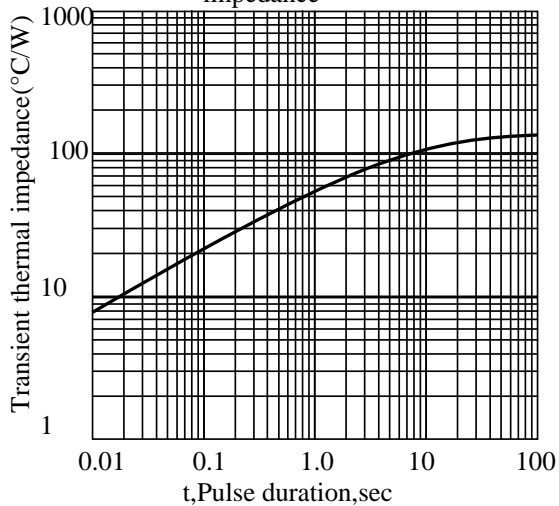
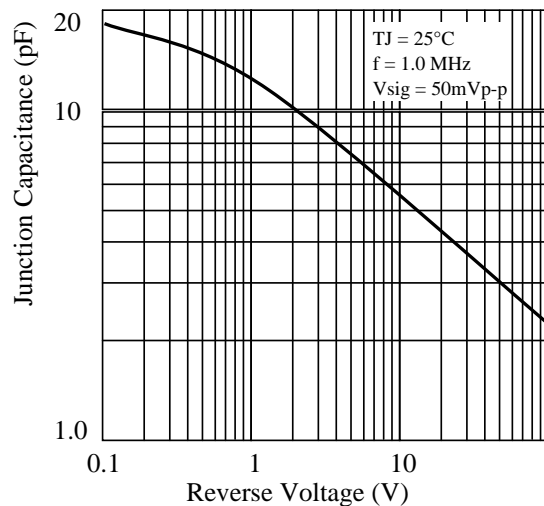

Fig. 6 - Typical Junction Capacitance



S2ABF thru S2MBF

3. dimension:

SMB-FL

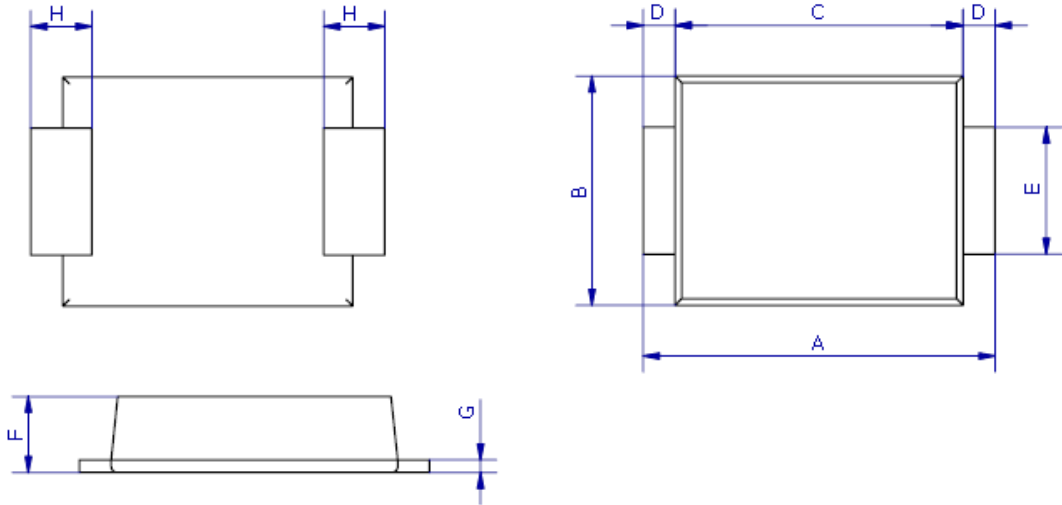

DIM	MILLIMETERS		INCHES	
	MIN	MAX	MIN	MAX
A	5.3	5.7	0.209	0.224
B	3.4	3.8	0.134	0.150
C	4.3	4.7	0.169	0.185
D	0.45Typ		0.018Typ	
E	1.9	2.1	0.0748	0.08268
F	1.05	1.40	0.04134	0.05512
G	0.2	0.3	0.00591	0.00984
H	0.95Typ		0.037Typ	

Mounting Pad Layout

--- SMB-FL

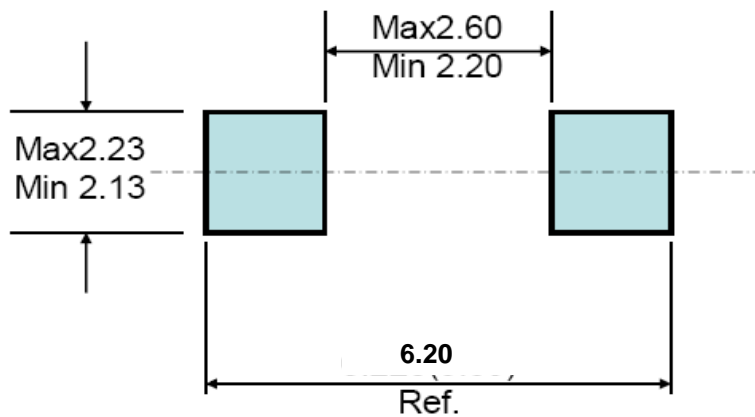

5.1 、 SMD Packing Reel Spec & Packing Quantity

5.1.1 Reel Packing
A. Reel Spec

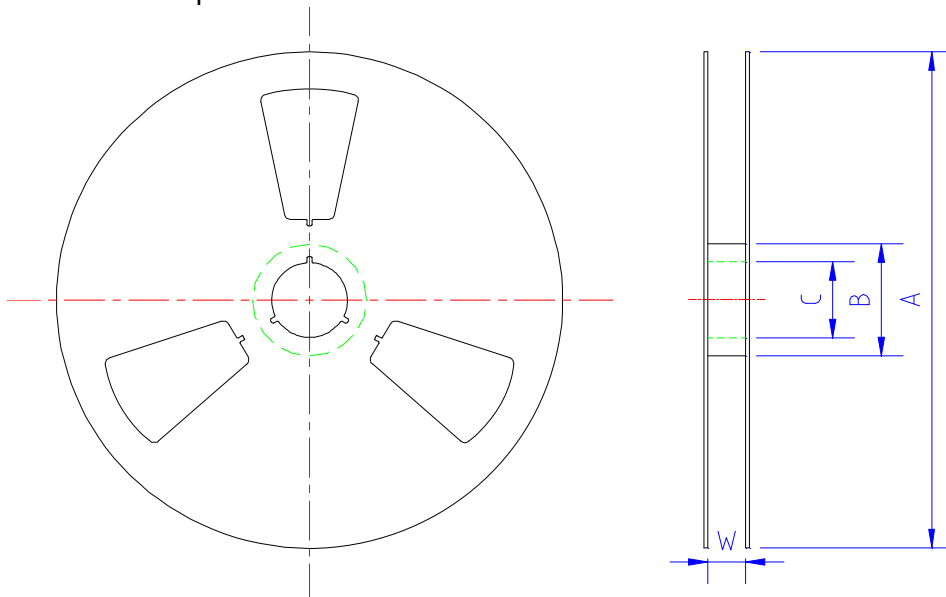

unit: mm

SPEC	A	B	C	W	Quantity/Reel
SMA 7" reel	177.0±2.0	54.0±0.5	13.0±0.5	13.2±0.2	2K
SMA13" reel	330.0±2.0	75.0±0.5	13.0±0.5	13.2±0.2	5K
SMA-FL13" reel	330.0±2.0	75.0±0.5	13.0±0.5	13.2±0.2	5K
TO277 13" reel	330.0±2.0	75.0±0.5	13.0±0.5	13.2±0.2	5K
SMB13" reel	330.0±2.0	75.0±0.5	13.0±0.5	13.5±0.5	3K
SMC13" reel	330.0±2.0	75.0±0.5	13.0±0.5	17.0±0.5	3K
SOD123FL 7" reel	177.0±2.0	50.0±0.5	13.0±0.5	9.4±1.5	3K
SOD323HE 7" reel	177.0±2.0	50.0±0.5	13.0±0.5	9.4±1.5	3K
SMB-FL 13" reel	330.0±2.0	75.0±0.5	13.0±0.5	13.2±0.2	5K

B. 13" reel packing box

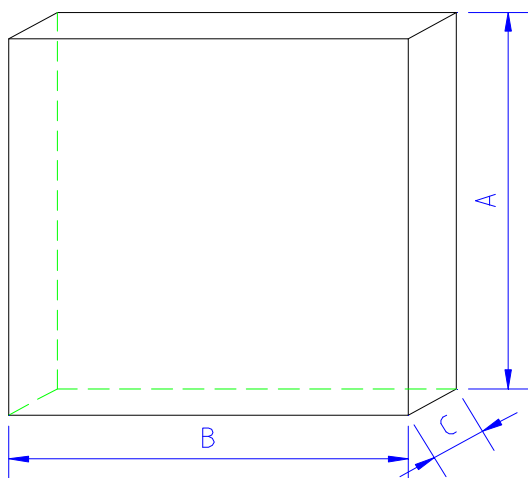

unit: mm

size	A	B	C
	335±5.0	335±2.0	40±1.0

as per above packing

Spec	Q' ty/Box
SMA13" reel	10K
SMB13" reel	6K
SMC13" reel	6K
TO277 13" reel	10K
SMB-FL 13" reel	10K

Title:
Power Diode SMD Package Packing Spec

DOC NO.: WI-258

DOC NO.: WI-258

Page: 3

C. 7" reel packing box

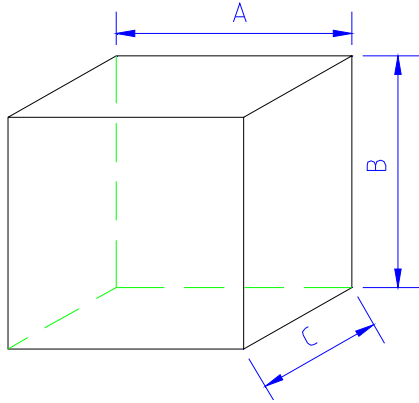

unit: mm

	A	B	C
SMA/SMA-FL	188±2.0	188±2.0	138±2.0
SOD123FL SOD323HE	186±2.0	139±2.0	185±2.0

as per above packing

	Q' ty/Box
SMA/SMA-FL	16K
SOD123FL	30K
SOD323HE	30K

D. reel packing carton

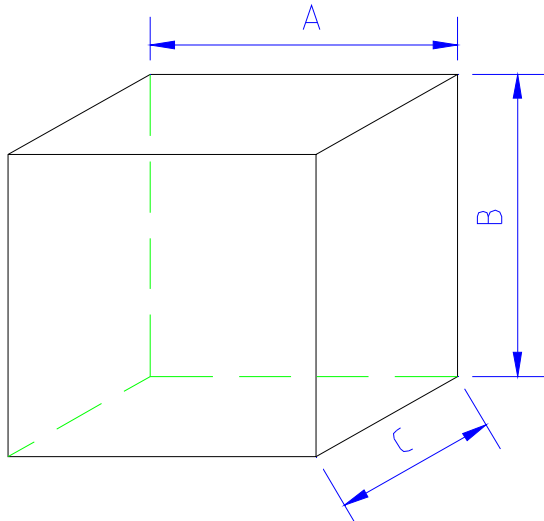

unit: mm

	A	B	C
size	350±2.0	340±2.0	350±2.0

as per above packing

Spec	Q' ty/Carton
SMA/SMA-FL 7" reel	80K
SMA13"reel	80K
SMB13"reel	48K
SMC13"reel	36K
SMA-FL13"reel	80K
TO277 13" reel	80K
SMB-FL 13" reel	80K

unit: mm

	A	B	C
SOD123FL SOD323HE	455±2.0	400±2.0	410±2.0

as per above packing

Spec	Q' ty/Carton
SOD123-FL 7" reel	360K
SOD323HE 7" reel	360K

5.1.2 Tape Spec

A. Cover Tape

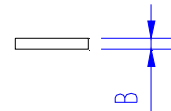

unit: mm

	A	B
SMA /SMA-FL SMB-FL /SMB /TO277	9.5±0.10	0.062±0.007
SMC	13.30±0.10	
SOD123FL SOD323HE	5.4±0.10	

B. Carrier Tape

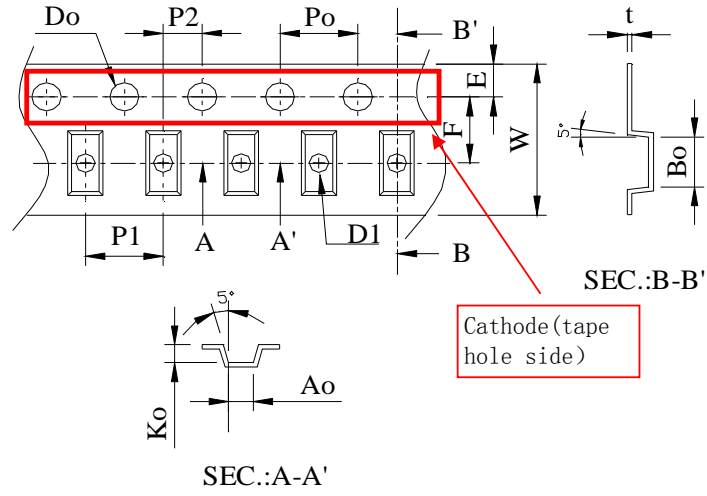

Item	SOD323HE	SOD123FL	SMA	SMA-FL	SMB	SMB-FL	TO277	SMC
W	8±0.3	8±0.3	12±0.3	12±0.3	12±0.3	12±0.3	12±0.3	16±0.3
P1	4±0.1	4±0.1	4±0.1	4±0.1	8±0.1	8±0.1	8±0.1	8±0.1
E	1.75±0.1	1.75±0.1	1.75±0.1	1.75±0.1	1.75±0.1	1.75±0.1	1.75±0.1	1.75±0.1
F	3.5±0.05	3.5±0.05	5.5±0.05	5.5±0.05	5.5±0.05	5.5±0.05	5.5±0.05	7.5±0.05
D0	1.55±0.05	1.55±0.05	1.55±0.05	1.55±0.05	1.55±0.05	1.55±0.05	1.55±0.05	1.55±0.05
D1	1.1±0.1	1.1±0.1	1.5±0.1	1.5±0.1	1.55±0.05	1.55±0.05	1.5±0.1	1.55±0.05
P0	4±0.1	4±0.1	4±0.1	4±0.1	4±0.1	4±0.1	4±0.1	4±0.1
P2	2±0.05	2±0.05	2±0.05	2±0.05	2±0.05	2±0.05	2±0.05	2±0.05
10P0	40±0.2	40±0.2	40±0.2	40±0.2	40±0.2	40±0.2	40±0.2	40±0.2
A0	1.45±0.1	1.95±0.1	2.79±0.1	2.83±0.1	3.8±0.1	3.8±0.1	4.3±0.1	6.05±0.1
B0	2.75±0.1	3.95±0.1	5.33±0.1	4.75±0.1	5.4±0.1	5.75±0.1	6.8±0.1	8.31±0.1
K0	0.80±0.1	1.30±0.1	2.36±0.1	1.42±0.1	2.45±0.1	1.4±0.1	1.35±0.1	2.54±0.1
T	0.25±0.05	0.25±0.05	0.25±0.05	0.25±0.05	0.25±0.05	0.25±0.05	0.25±0.05	0.25±0.05

5.2、SMD Power Diode General Packing Spec

A. 7" reel all labels will be at cathode side of reel ;

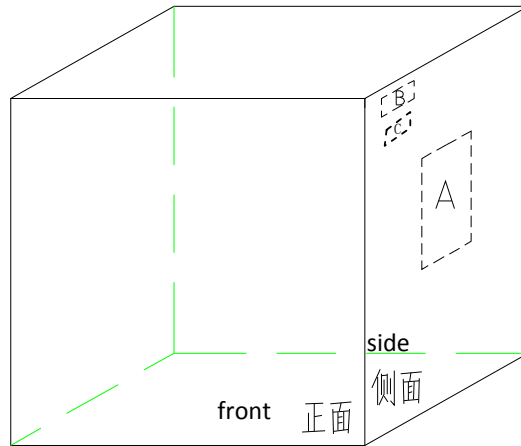
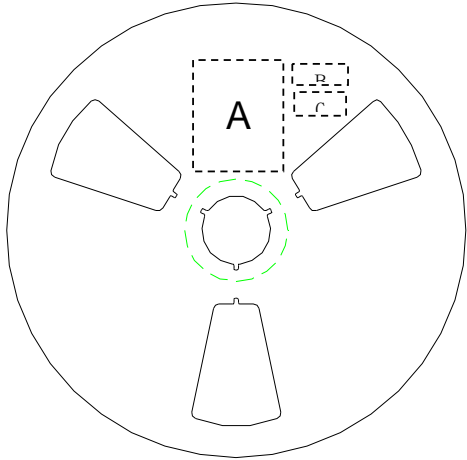

A:LRC label;

B:Environment Label C:Halide free label

B. 13" reel

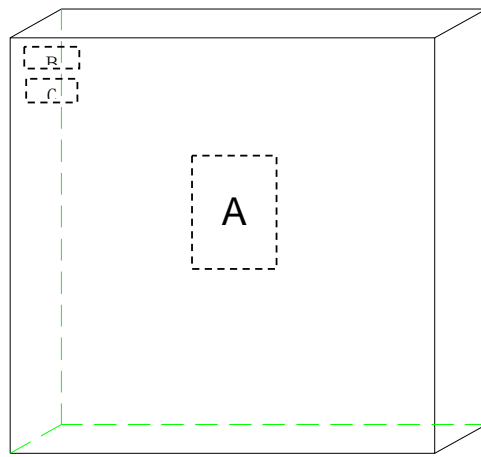
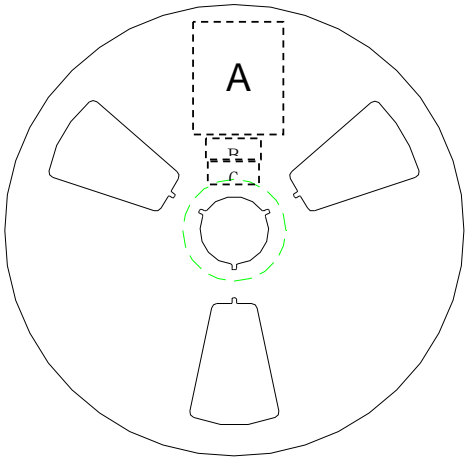

A:LRC label;

B:Environment Labe C:Halide free label

C. Tape lead: face anode side of the reel, upper side is the tape lead position. All labels are at cathode side of the reel.



标题:

Power Diode SMD Package Packing Spec

DOC NO.: WI-258

Version: 5 Modification: 0

Page: 6

C. Label Content :
LRC Label

P/N → (1P) LPN: SM140A
Lot No. → (1T) LOT: 140106049X
Date code → (9D) DTE: 1403
Quantity → (Q) QTY: 10000

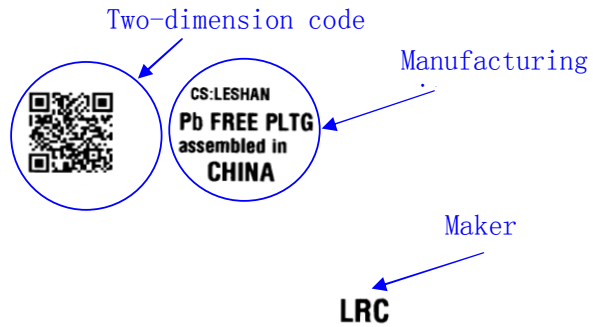

lot: 140106049X: 140106---2014/1/6; 049----lot number:49; X: product code

Environment Label



Halide-free Label



S2ABF thru S2MBF

4. Update Record

版次	更新记录	更新作者	更新日期
1	第一版	周杰	2014. 04. 30

单击下面可查看定价，库存，交付和生命周期等信息

[>>LRC\(乐山无线电\)](#)