

SST-90-W LEDs

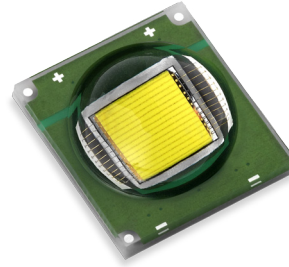

Table of Contents

Technology Overview2

Binning Structure3

Ordering Information5

Shipping and Labeling6

Electrical Characteristics...7

Product Characteristics...8

Mechanical Dimensions.. 11

Solder Profile 14

Tape and Reel Drawing ... 15

History of Changes 16

Features:

- Extremely high optical output White LED: up to 4,000lm at 18A
- 5700K Daylight and 6500K Cool White color points available.
- High thermal conductivity package - junction to case thermal resistance of only 0.5 °C/W
- Large, monolithic chip with uniform emitting area of 9 mm²
- Variable drive currents: less than 1 A through 18 A continuous waveform.
- Electrically isolated thermal path
- Environmentally friendly: RoHS compliant

Applications

- Machine vision
- High- output strobing applications
- Beacons, obstruction Lighting
- Industrial Applications
- Portable Lighting
- Medical Lighting
- Emergency Vehicle Lighting
- Displays and Signage
- High-output, directional transportation lighting
- Search Lights
- Work Lights

Technology Overview

Luminus LEDs™ benefit from a suite of innovations in the fields of chip technology, packaging and thermal management. These breakthroughs allow illumination engineers and designers to achieve solutions that are high brightness and high efficiency.

Luminus Technology

Luminus' technology enables large area LED chips with uniform brightness over the entire LED chip surface. The optical power and brightness produced by these large monolithic chips enable solutions which replace arc and halogen lamps where arrays of traditional high power LEDs cannot.

Packaging Technology

Thermal management is critical in high power LED applications. With a thermal resistance from junction to case of 0.5° C/W. Luminus SST-90-W LEDs have the lowest thermal resistance of any LED on the market. This allows the LED to be driven at higher current densities while maintaining a low junction temperature, thereby resulting in brighter solutions and longer lifetimes.

Reliability

Designed from the ground up, Luminus LEDs are one of the most reliable light sources in the world today. Luminus LEDs have passed a rigorous suite of environmental and mechanical stress tests, including mechanical shock, vibration, temperature cycling and humidity, and have been fully qualified for use in extreme high power and high current applications. With very low failure rates and median lifetimes that typically exceed 60,000 hours, Luminus LEDs are ready for even the most demanding applications.

Environmental Benefits

Luminus LEDs help reduce power consumption and the amount of hazardous waste entering the environment. All LED products manufactured by Luminus are RoHS compliant and free of hazardous materials, including lead and mercury.

Understanding Luminus LED Test Specifications

Every Luminus LED is fully tested to ensure that it meets the high quality standards expected from Luminus' products.

Testing Temperature

Luminus surface mount LEDs are typically tested with a 20mSec input pulse and a junction temperature of 25°C. Expected flux values in real world operation can be extrapolated based on the information contained within this product data sheet.

Large Operating Range

The tables on the following pages provide typical optical and electrical characteristics. Since the LEDs can be operated over a wide range of drive conditions (currents from less than 1.0 A to 18.0 A, and duty cycle from <1% to 100%), multiple drive conditions are listed.

SST-90-W LEDs are production tested at 3.15 A. The values shown at other 6.3 A and 9.0 A are for additional reference at other possible drive conditions.

SST-90-W White Binning Structure

SST-90-W white LEDs are tested for luminous flux and chromaticity at a drive current of 3.15 A (350 mA/mm²) and placed into one of the following luminous flux (FF) and chromaticity (WW) bins. Please note that single bins cannot be ordered. Refer to ordering information to see the highest minimum bin orderable.

Flux Bins

Flux Bin (FF)	Minimum Flux (lm) @ 3.15A	Maximum Flux (lm) @ 3.15A
N2	900	950
N3	950	1,000
P	1000	1060
P2	1060	1130
P3	1130	1200

*Note: Luminus maintains a +/- 6% tolerance on flux measurements.

Chromaticity Bins

Luminus' Standard Chromaticity Bins: 1931 CIE Curve

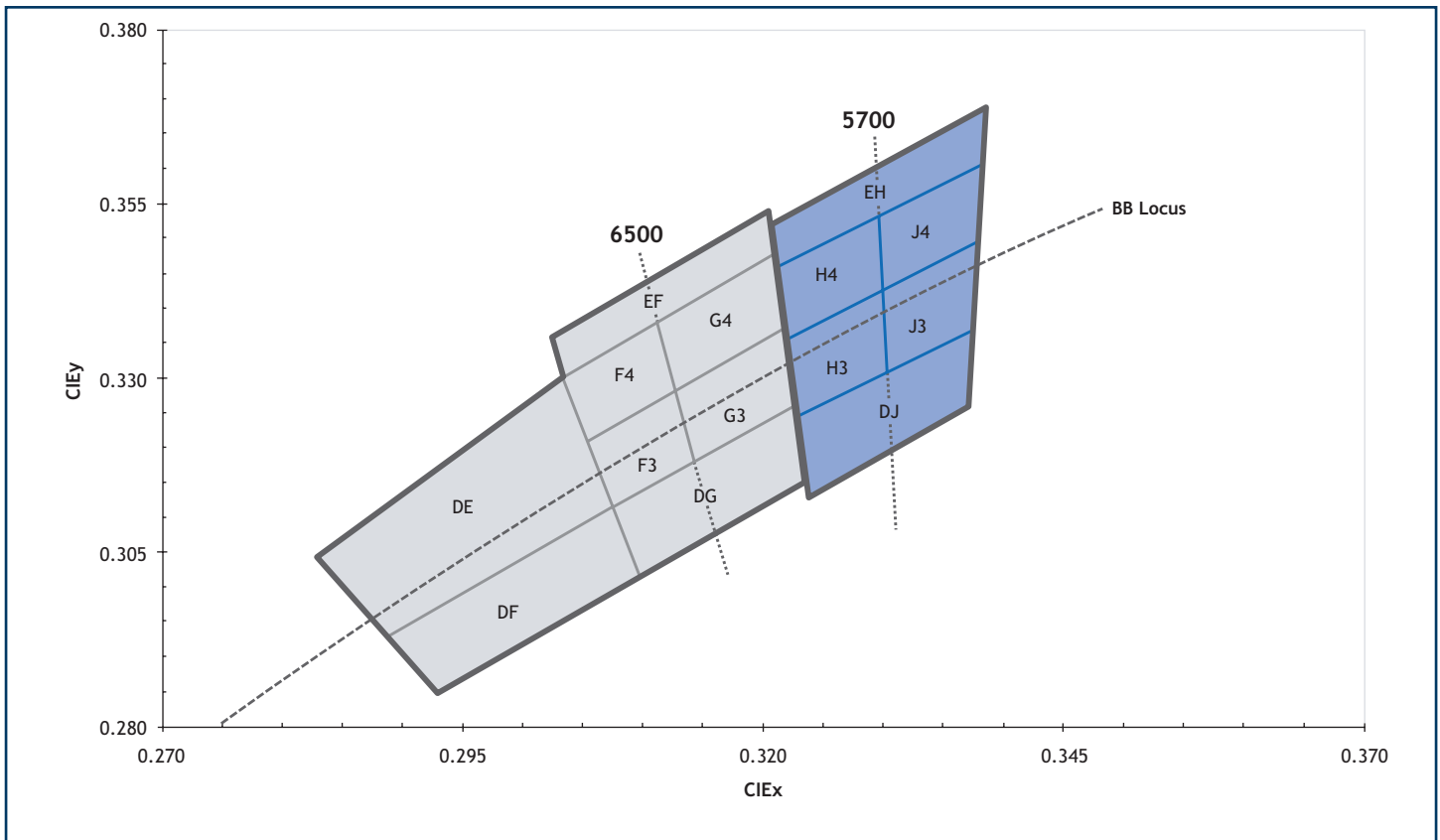

The following tables describe the four chromaticity points that bound each chromaticity bin. Chromaticity bins are grouped together based on the color temperature.

6500K Chromaticity Bins		
Bin Code (WW)	CIE _x	CIE _y
DG	0.307	0.311
	0.322	0.326
	0.323	0.316
	0.309	0.302
F3*	0.305	0.321
	0.313	0.329
	0.315	0.319
	0.307	0.311
F4*	0.303	0.330
	0.312	0.339
	0.313	0.329
	0.305	0.321
G3*	0.313	0.329
	0.321	0.337
	0.322	0.326
	0.315	0.319
G4*	0.312	0.339
	0.321	0.348
	0.321	0.337
	0.313	0.329
EF	0.302	0.335
	0.320	0.354
	0.321	0.348
	0.303	0.330
DE	0.283	0.304
	0.303	0.330
	0.307	0.311
	0.289	0.293
DF	0.289	0.293
	0.307	0.311
	0.309	0.302
	0.293	0.285

5700K Chromaticity Bins		
Bin Code (WW)	CIE _x	CIE _y
DJ	0.322	0.324
	0.337	0.337
	0.336	0.326
	0.323	0.314
H3*	0.321	0.335
	0.329	0.342
	0.329	0.331
	0.322	0.324
H4*	0.321	0.346
	0.329	0.354
	0.329	0.342
	0.321	0.335
J3*	0.329	0.342
	0.337	0.349
	0.337	0.337
	0.330	0.331
J4*	0.329	0.354
	0.338	0.362
	0.337	0.349
	0.329	0.342
EH	0.320	0.352
	0.338	0.368
	0.338	0.362
	0.321	0.346

*Sub-bins within ANSI defined quadrangles per ANSI C78.377-2008

Note : CIE Measurement uncertainty for white devices is in estimated to be +/- 0.01

Ordering Information

SS<X>
90
W<NN>S
<Z>11
<abnnn>

Product Family	LED Emission Area	Color	Package Configuration	Bin kit
SST: Surface mount device, Encapsulated SSR: Surface mount device mounted on an aluminum star board	90: 9.0 mm ²	W = White NN: 57=5700k 65=6500k S: Standard CRI	F11: 10.0 mm x 11.0 mm - Surface mount, shipped in 25 unit trays. T11:surface mount, shipped in tape and reel [see p15] R11: Surface mount device mounted on an aluminum star board (15/tray)	Flux and Chromaticity bin kit code - See available ordering codes below

SST-90-W and SSR-90-W Bin Kit Order Codes

The following table describes the bin kit ordering codes for the SST-90-W and SSR-90-W. Each kit specifies a minimum flux and allowed chromaticity bins. A maximum flux is not specified. Within each kit, Luminus may ship any part meeting or exceeding the minimum flux specification as well as chromaticity specification but no specific mix of bins is guaranteed.

Color	Luminous Flux		Chromaticity Bins	Kit Number
	Bin Kit Flux Code	Min. Flux		
White W65S 6500K, Standard CRI (typ. 70)	N2	900	F4, F3, G4, G3, EF, DG, DE, DF	N2100
			F4, F3, G4, G3, EF, DG	N2101
			F4, F3, G4, G3	N2102
	N3	950	F4, F3, G4, G3, EF, DG, DE, DF	N3100
			F4, F3, G4, G3, EF, DG	N3101
			F4, F3, G4, G3	N3102
White WDLS 6500K & 5700K Standard CRI (typ. 70)	N2	900	F4, F3, G4, G3, EF, DG, DE, DF H4, H3, J4, J3, EH, DJ	N2150
	N3	950	F4, F3, G4, G3, EF, DG, DE, DF H4, H3, J4, J3, EH, DJ	N3150
White W57S 5700K, Standard CRI (typ. 70)	N2	900	H4, H3, J4, J3, EH, DJ	N2200
			H4, H3, J4, J3	N2201
	N3	950	H4, H3, J4, J3, EH, DJ	N3200
			H4, H3, J4, J3	N3201

Product Shipping & Labeling Information

All SST-90-W products are packaged and labeled with their respective bin as outlined in the tables and charts from pages 3 to 4. When shipped, each package will only contain one flux and chromaticity bin. Note the exception: Tape and Reel packaging for SST-90-W65S, SST-90-W57S, and SST-90-WDLS may contain multiple chromaticity bins but only a single flux bin.

Product Label Information:

- Ordering part number (see page5) - Example: SST-90-W57S-F11-N2201
- Box / Tray / Reel ID (Luminus Internal Use)
- Quantity
- Bin = FF - WW (See pages 3 and 4 for definitions)

Electrical Characteristics¹

Optical and Electrical Characteristics (T_j = 25 °C)

Drive Condition ²		3.15 A	9.0 A	
Parameter	Symbol	Values at Test Currents	Typical Values at Indicated Current ³	Unit
Current Density	j	0.35	1.0	A/mm ²
Forward Voltage	V _{F, min}	2.5		V
	V _{F, typ}	3.25	3.87	V
	V _{F, max}	3.9		V

Common Characteristics

Parameter	Symbol	Values	Unit
Viewing Angle (Typical)	2 θ _{1/2}	110	°C
Emitting Area		9.0	mm ²
Emitting Area Dimensions		3 x 3	mm×mm
Forward Voltage Temperature Coefficient		-2.45	mV/°C

Absolute Maximum Ratings

Parameter	Symbol	Values	Unit
Minimum Drive Current ⁴		0.2	A
Maximum Current ³ (CW)		18	A
Absolute Maximum Surge Current 25 ms, D ≤ 0.1, T _c ≤ 40 C		27	A
Maximum Reverse Current		Not Designed for Reverse Operation	
Maximum Junction Temperature ⁶	T _{j-max}	150	°C
Storage Temperature Range		-40/+100	°C

Note 1: SST-90-W devices can be driven at currents ranging from <1A to 18A and at duty cycles ranging from <1% to 100%. Drive current and duty cycle should be adjusted as necessary to maintain the junction temperature desired to meet application lifetime requirements.

Note 2: Unless otherwise noted, values listed are typical.

Note 3: Sustained operation at absolute maximum currents will result in a reduction of device lifetime. In pulsed operation, rise time from 10-90% of forward current should be larger than 0.5 microseconds. Lifetime dependent on LED junction temperature. Thermal calculations based on input power and thermal management system should be performed to ensure T_j is maintained below T_{j-max} rating or life will be reduced. Refer to APN-001522 for further information.

Note 4: Special design considerations must be observed for operation under 1A. Please contact Luminus for further information.

Note 5: Caution must be taken not to stare at the light emitted from these LEDs. Under special circumstances, the high intensity could damage the eye.

Note 6: Sustained operation at Absolute Maximum Operating Junction Temperature (T_{jmax}) will result in significantly reduced device life time. Please refer to AN1522 for more information

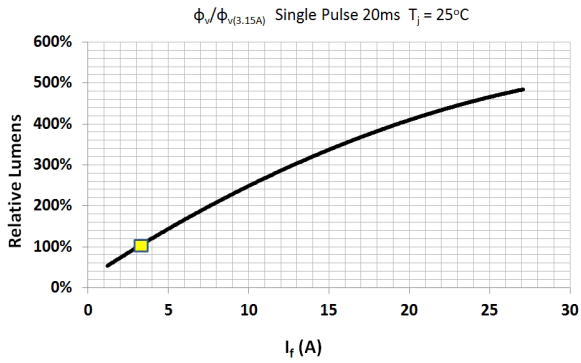
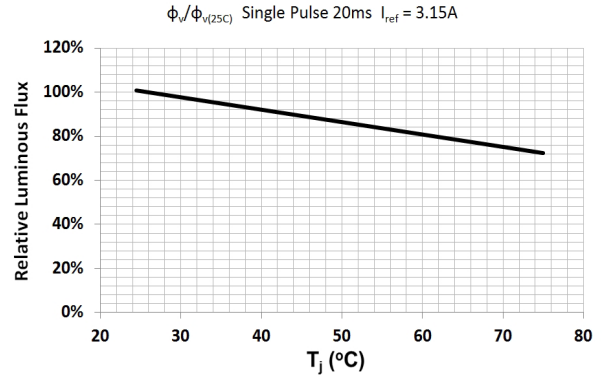
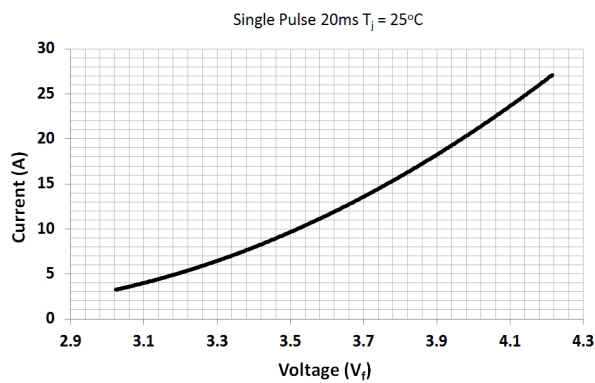
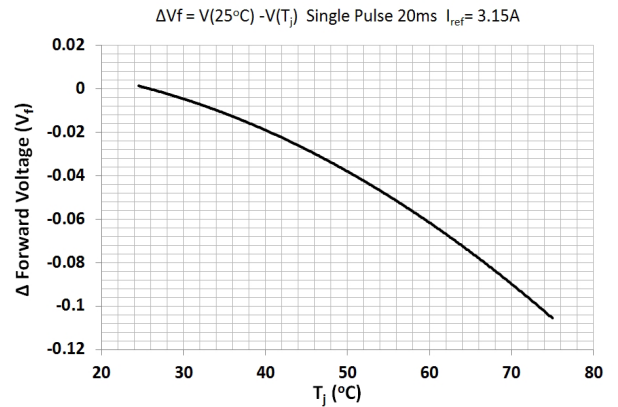
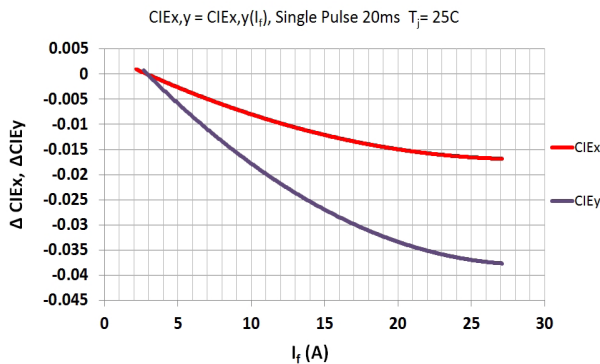
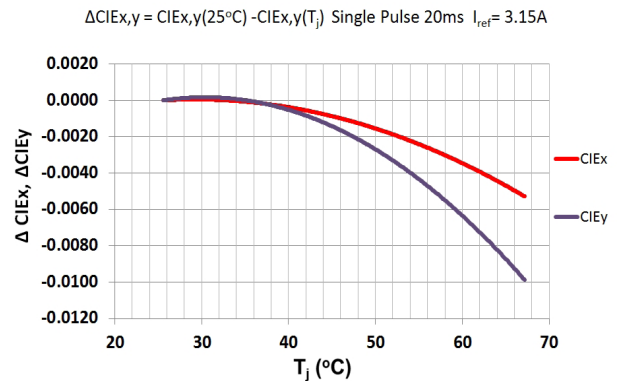
Relative Output Flux vs. Forward Current¹

Relative Output Flux vs. T_j

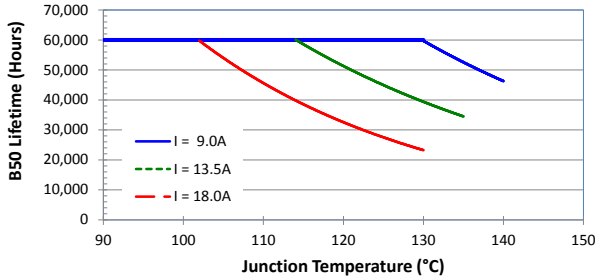
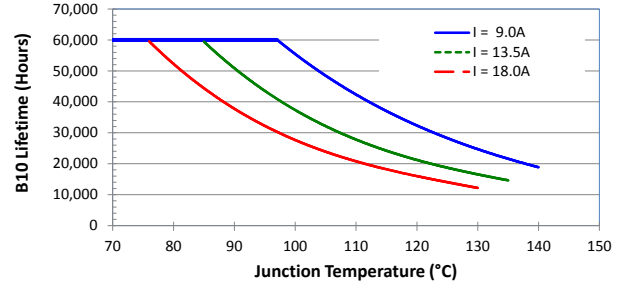
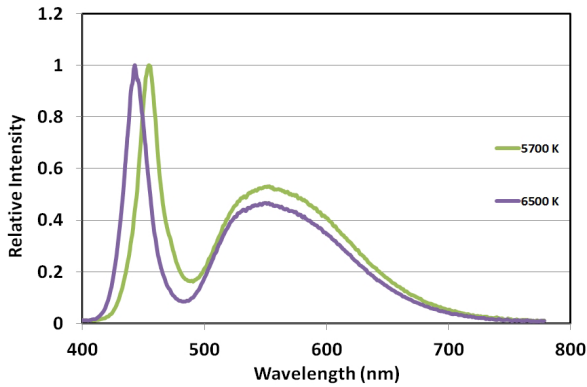
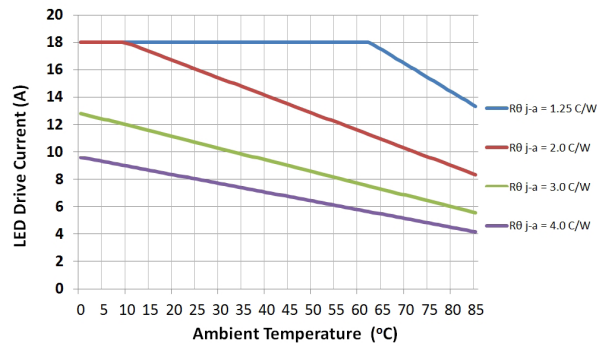
Forward Current vs. Forward Voltage

Forward Voltage Shift vs. T_j

Chromaticity Coordinates Shift vs. I_f

Chromaticity Coordinates Shift vs. T_j

Note 1: Yellow squares indicate devices production test point.

B50 projected Median Lifetime¹

B10 Projected median Lifetime¹

Typical Relative Spectral Power²

Current Derating Curve

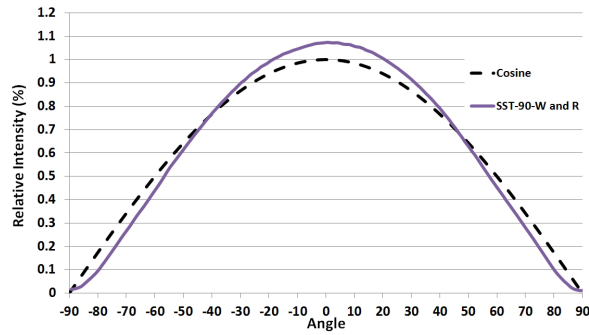
Note 1: B10 and B50 median lifetimes refers to 90% and 50% brightness maintenance respectively refer to AN-1522 Application note for more information

Note 2: Typical spectrum at current density of 0.35 A/mm² in continuous operation.

Typical Angular Radiation Pattern



Thermal Resistance

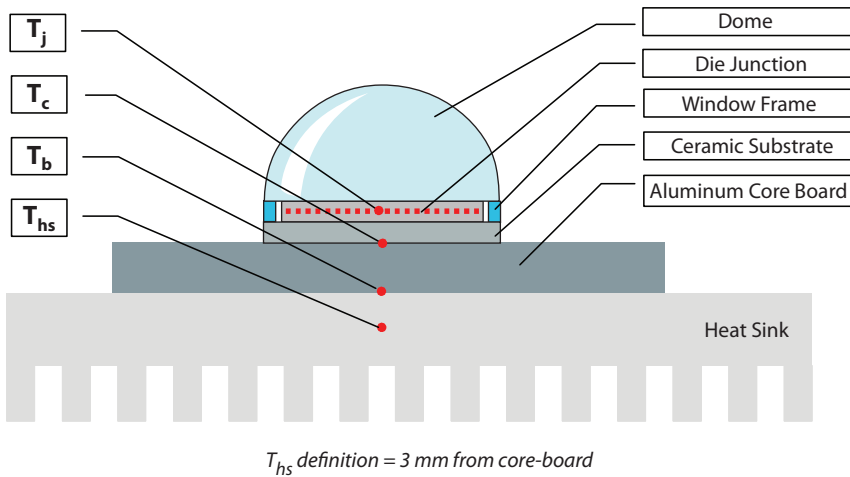

Typical Thermal Resistance

R_{j-c}^1	0.50 °C/W
R_{j-b}^1	1.20 °C/W
R_{j-hs}^2	1.40 °C/W

Note 1: Thermal resistance values are based on FEA model results correlated to measured $R_{\theta j-hs}$ data.

Note 2: Thermal resistance is measured using a SAC305 solder, a Bergquist Al-clad MCPCB, and eGraf 1205 thermal interface material.

Note: Luminus currently ships both an overmolded and a glass lens-based version of the SST-90-W package that are functionally compatible

Mechanical Dimensions – SST-90-W Over-Molded

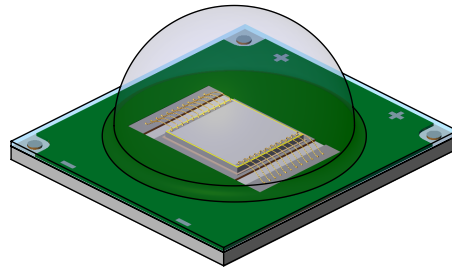

DIMENSIONS IN MILLIMETERS

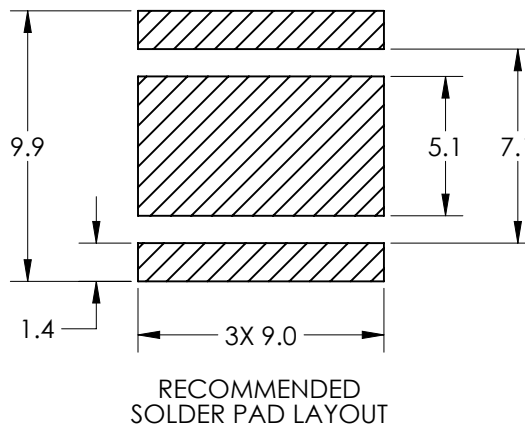
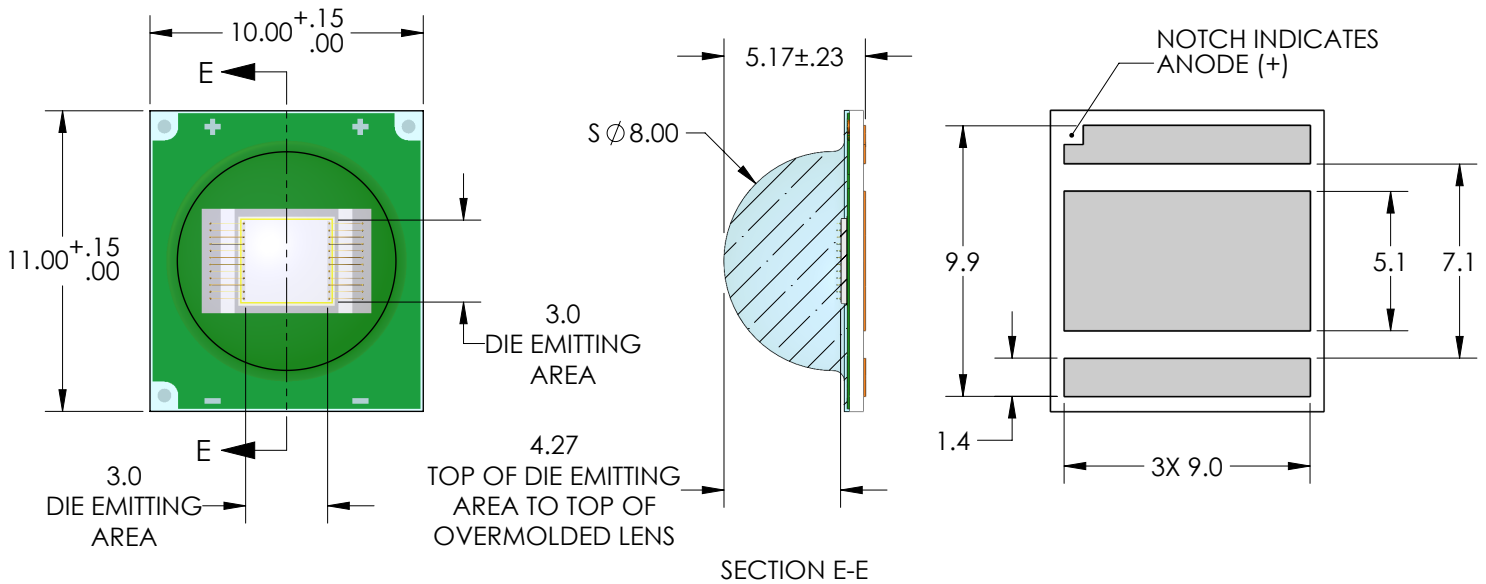

For detailed drawing please refer to DWG-002519 document

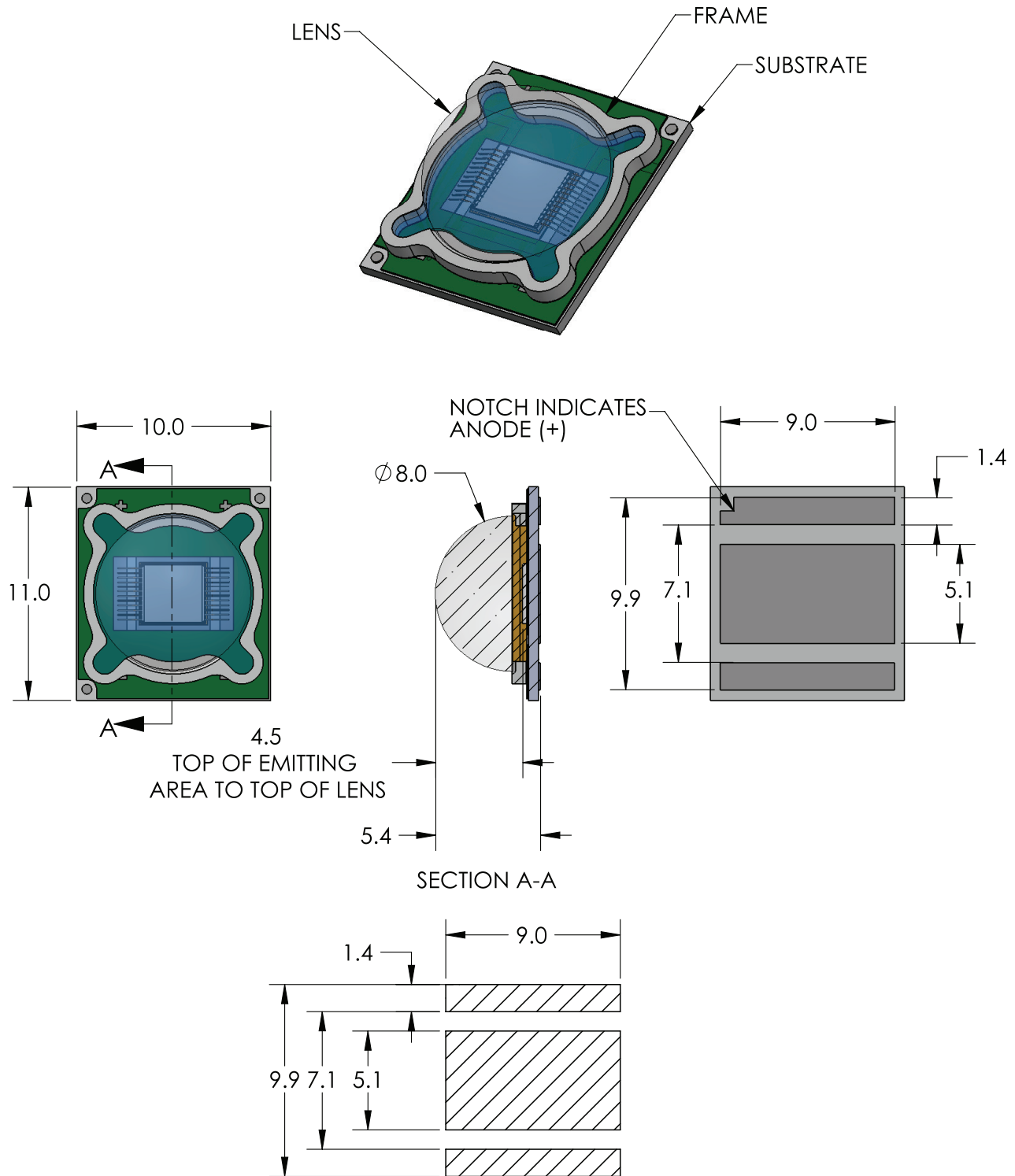
Mechanical Dimensions – SST-90-W with metal frame and glass lens (Original Design)

For detailed drawing please refer to DWG-001359 document

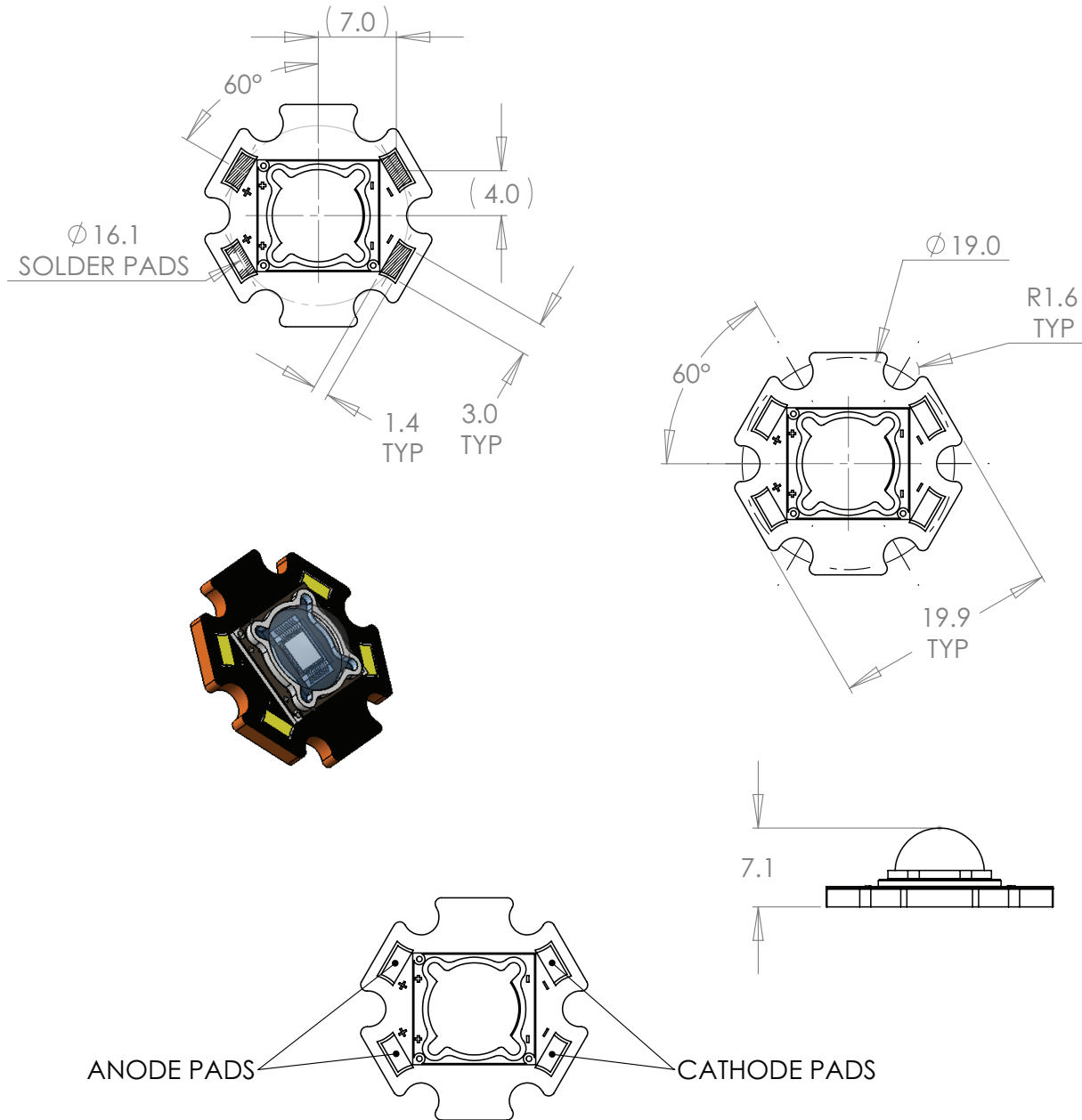
Mechanical Dimensions – SST-90-W Star Board

Note 1: Recommended mounting screw: M3 or #4

Note 2: All dimensions in millimeters

Note 3: All anode pads on board are interconnected. All cathode pads on board are interconnected

Solder Profile

SAC 305 Reflow Profile Window For Low Density Boards

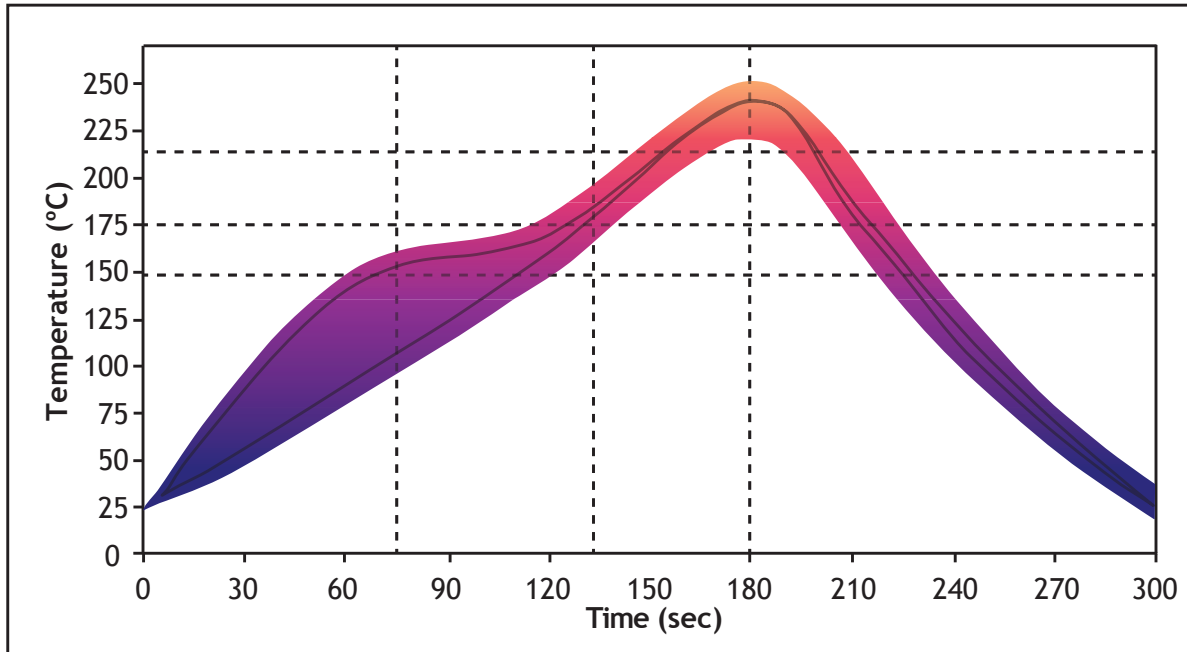

Lead free solder guideline for low density boards

Solder Profile Stage	Lead-Free Solder	Lead-based Solder
Profile length, Ambient to Peak	2.75 - 3.5 minutes	2.75 - 3.5 minutes
Time Maintained Above: Temperature	217 °C	183 °C
Time Maintained Above: Time	30 - 60 seconds	30 - 60 seconds
Cooldown Rate	≤4° C/sec	≤4° C/sec
Cooldown Duration	45 ± 15 sec	45 ± 15 sec

Note 1: Temperatures are taken and monitored at the component copper layer.

Note 2: Optimum profile may differ due to oven type, circuit board or assembly layout.

Note 3: Recommended lead free, no-clean solder: AIM NC254-SAC305.

Note 4: Refer to APN-001473 soldering and handling application note for additional solder profiles and details.

Note 5: MSL- Level 2A (Glass Lens); MSL Level 1 (Over Molded Design)

Tape and Reel Drawing

DIMENSIONS ARE IN mm. (INCH)

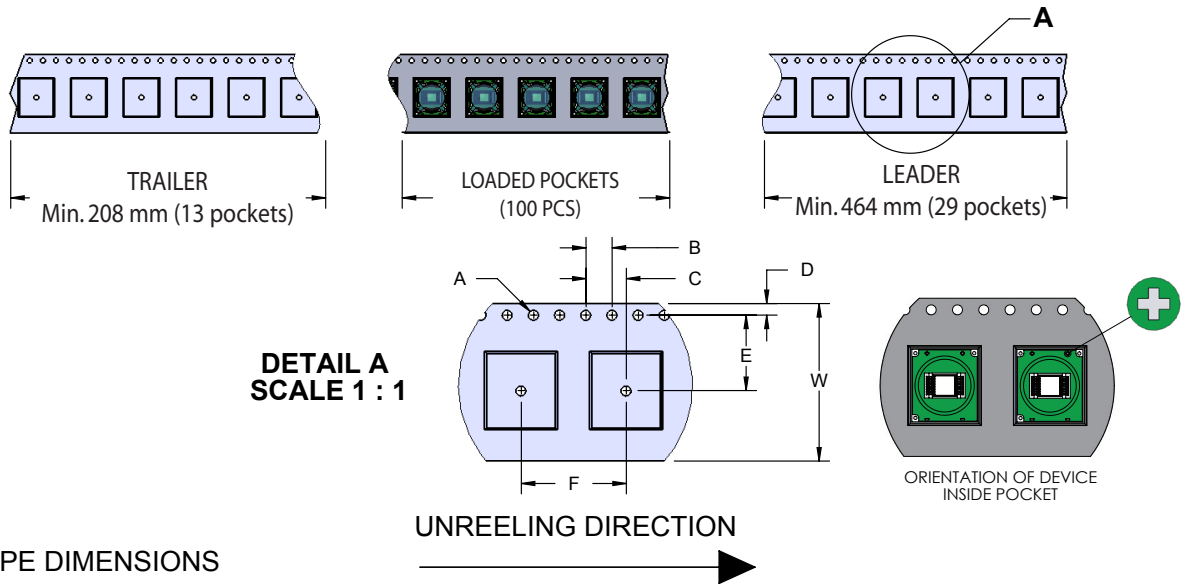

TAPE DIMENSIONS

W	A	B	C	D	E	F
24.0 (.945)	∅ 1.5 (.059)	4.0 (.157)	6.0 (.236)	1.7 (.067)	11.5 (.453)	16.0 (.630)

UNREELING DIRECTION

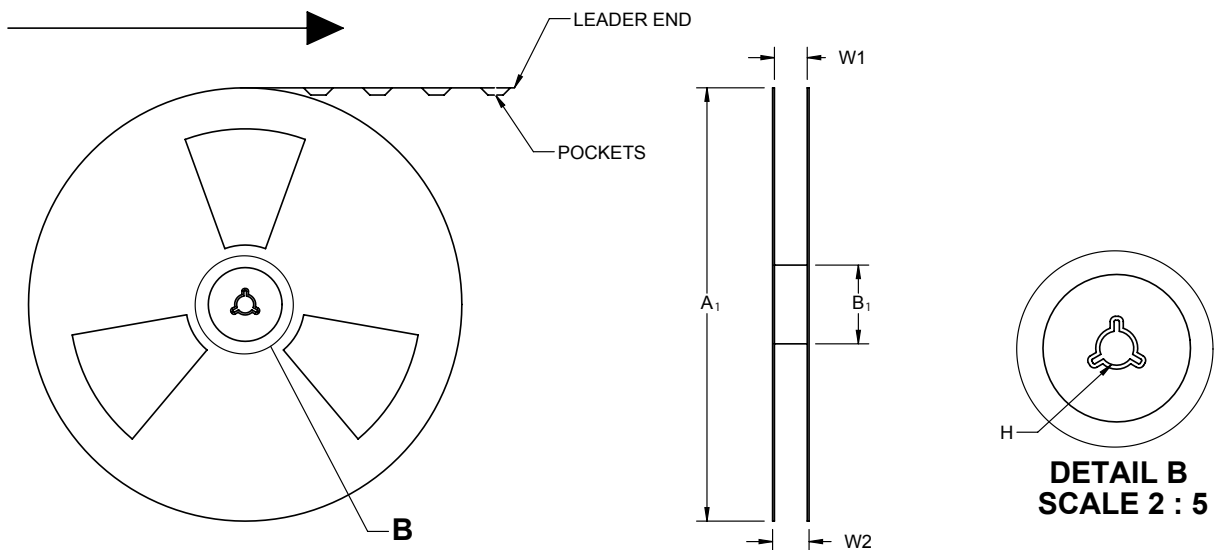

REEL DIMENSIONS

A ₁	W ₁	W ₂	B ₁	H
∅ 178 (7)	25 (.984)	27 (1.063)	59 (2.323)	∅ 13.0 (.512)

History of Changes

Rev	Date	Description of Change
14	09/30/2015	<ul style="list-style-type: none"> • Removed SST-90-G and SST-90-B information (discontinued) • Removed SST-90-R information – it will be documented in a new dedicated datasheet (PDS-002760) • Merged binning and labelling document with datasheet • Updated datasheet information to reflect enhancements from the over-molded design: • Reduced thermal resistance • Increase maximum current • Updated all parametric curves to reflect latest performance and added additional curves not documented in earlier revisions • Updated spectra and angular distribution to reflect latest characterization data • Added note on Tape and Reel drawing reflecting new reel size of 100 units for overmold design • Added history of change section • Editorial fixes
15	11/16/2015	<ul style="list-style-type: none"> • Updated tape and reel information to reflect new 7" reel size (100 units) • Editorial fixes page 7 – notes and absolute maximum surge current

The products, their specifications and other information appearing in this document are subject to change by Luminus Devices without notice. Luminus Devices assumes no liability for errors that may appear in this document, and no liability otherwise arising from the application or use of the product or information contained herein. None of the information provided herein should be considered to be a representation of the fitness or suitability of the product for any particular application or as any other form of warranty. Luminus Devices' product warranties are limited to only such warranties as accompany a purchase contract or purchase order for such products. Nothing herein is to be construed as constituting an additional warranty. No information contained in this publication may be considered as a waiver by Luminus Devices of any intellectual property rights that Luminus Devices may have in such information.

This product is protected by U.S. Patents 6,831,302; 7,074,631; 7,083,993; 7,084,434; 7,098,589; 7,105,861; 7,138,666; 7,166,870; 7,166,871; 7,170,100; 7,196,354; 7,211,831; 7,262,550; 7,274,043; 7,301,271; 7,341,880; 7,344,903; 7,345,416; 7,348,603; 7,388,233; 7,391,059 Patents Pending in the U.S. and other countries.

单击下面可查看定价，库存，交付和生命周期等信息

[>>Luminus Devices\(朗明纳斯\)](#)