

Latch, Hall-Effect Magnetic Position Sensor

1 Product Description

The MT816X family is produced by BCD technology with both high performance and high reliability. The Hall IC internally includes an on-chip Hall voltage generator, a voltage regulator for operation with supply voltage of 2.8V to 24V, a small-signal amplifier, Hall sensors with dynamic offset cancellation, a schmitt trigger and an open-drain output with over-current protection. It features temperature compensation technique to make the magnetic switching points stable over a wide temperature range. Other key features such as reverse supply voltage protection, output over-current protection and ESD level exceeding $\pm 5.5\text{KV}$ (HBM) make the IC extremely robust and fault tolerant, which is important in demanding application environment such as automotive. Its extremely low operating supply voltage 2.8V also makes it possible to add external resistance in series with the supply pin for even greater protection against high voltage transients from the power supply.

When the magnetic flux density (B) is greater than the operating point (BOP), the output turns on (Low). The output is held steady till the magnetic flux density (B) is less than the releasing point (BRP), at which point it turns off (High).

2 Features

- BCD Technology
- Latch Switch
- 2.8~24V Operating Vcc Range
- -40°C~150°C Operating Temperature
- Package Option:
Flat TO-92 / SOT-23 / SOT-23 (Thin Outline) / WLCSP
- Magnetic Sensitivity Option:
MT8161 (BOP=20Gs, BRP=-20Gs)
MT8162 (BOP=60Gs, BRP=-60Gs)
- Open-Drain Output
- -27V Reversed Power Supply Protection
- Output Limiting Current Protection
- RoHS Compliant: (EU)2015/863

3 Product Overview of MT816X

Part No.	Description
MT816XA	Flat TO-92, bulk packaging (1000pcs/bag)
MT816XAT	SOT-23, tape & reel (3000pcs/bag)
MT816XET	SOT-23 (thin outline), tape & reel (3000pcs/bag)
MT816XCSP	WLCSP, tape & reel (3000pcs/bag)

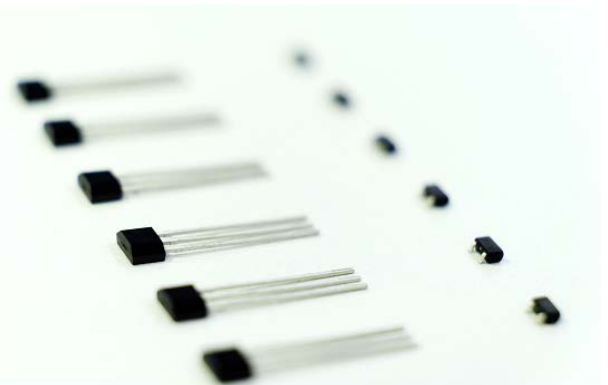

4 Applications

- Home appliances
- Industrial
- Speed Detection
- Brushless DC Motor Communication

5. Pin Configuration and Functions

	Vcc	Out	GND
SOT-23	1	2	3
SOT-23 Thin Outline	1	2	3
Flat TO-92	1	3	2
WLCSP	A1	B2	B1
Description	Power	Output Open-Drain	Ground

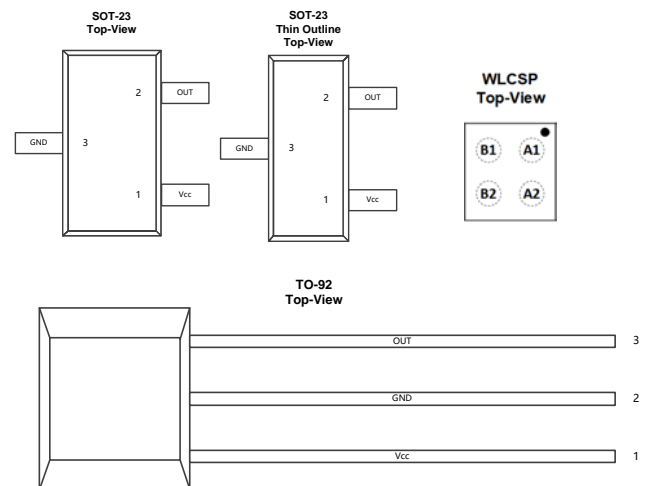

Figure.1 Pin Configuration & Functions

Table of Contents

1	Product Description.....	1
2	Feature.....	1
3	Product Overview of MT816X	1
4	Applications.....	1
5	Pin Configuration and Functions.....	1
6	Definition of Switching Function.....	3
7	Function Description.....	3
8	Feature Description.....	3
9	Functional Block Diagram.....	4
10	Electrical and Magnetic Characteristics.....	4
	10.1 Absolute Maximum Ratings.....	4
	10.2 Electrical Specifications.....	5
	10.3 Magnetic Characteristics.....	5
	10.4 ESD Ratings.....	5
	10.5 Characteristic Performance.....	6
	10.6 Typical Output Waveform.....	7
11	Typical Application Circuit.....	7
12	Package Material Information.....	8
	12.1 SOT-23 Package Information.....	8
	12.2 SOT-23 Thin Outline Package Information.....	9
	12.3 Flat TO-92 Package Information.....	10
	12.4 WLCSP Package Information.....	11
13	Copy Rights and Disclaimer.....	12

Reversion History

1	Originally Version	
2	1.1 Version	Update BOP & BRP Update Copy Rights and Disclaimer
3	1.2 Version	Update the marking spec of SOT-23 & SOT-23 (Thin Outline)
4	1.3 Version	Update MT8161CSP
5	1.4 Version	Update the Logo of MagnTek
6	1.5 Version	Update MT8162 series

6 Definition of Switching Function

Figure.2 & Figure.3 shows the device functionality and hysteresis

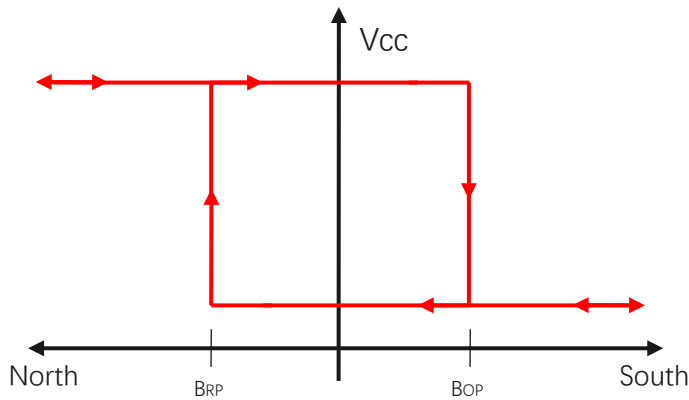

Figure.2 Switching Function of Flat TO-92 & SOT-23 (Thin Outline)

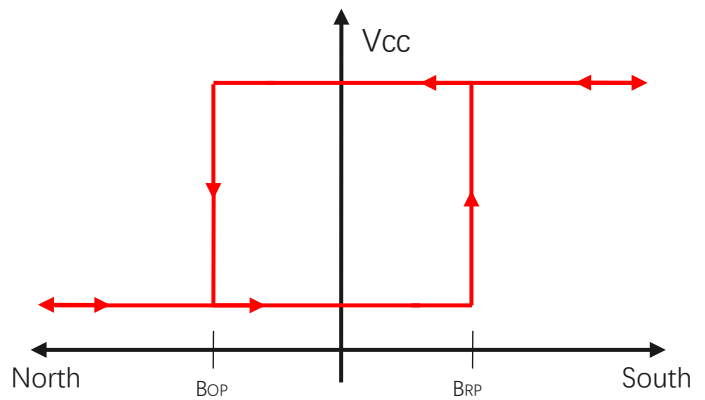

Figure.3 Switching Function of SOT-23 & WLCSP

7 Function Description

B_{OP}: Operating Point, Magnetic flux density applied on the branded side of the package which turns the output driver ON ($V_{OUT}=Low$)

B_{RP}: Releasing Point, Magnetic flux density applied on the branded side of the package which turns the output driver OFF ($V_{OUT}=High$)

B_{HYST}: Hysteresis Window, $|B_{OP} - B_{RP}|$

Devices that have a lower magnetic threshold ($V_{OUT}=High$) detect magnets at a farther distance. Higher thresholds ($V_{OUT}=Low$) generally require a closer distance or larger magnet.

8 Feature Description

The MT816X device is sensitive to the magnetic field component that is perpendicular to the top of the package

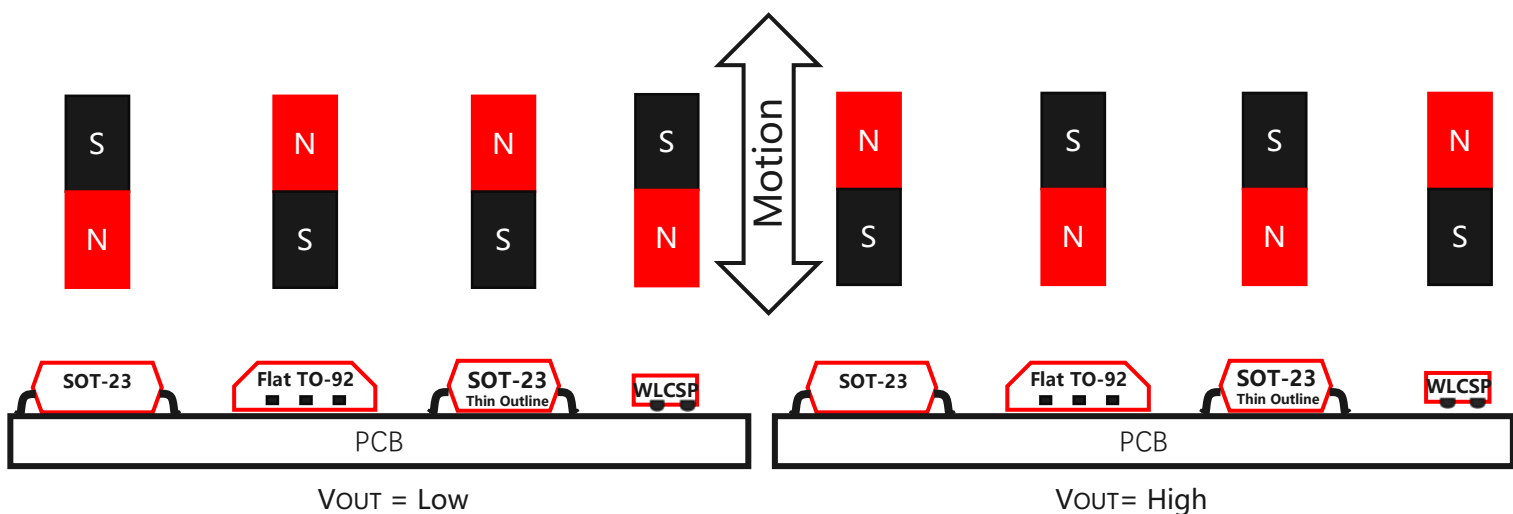

Figure.4 Flux Direction Polarity

9 Functional Block Diagram

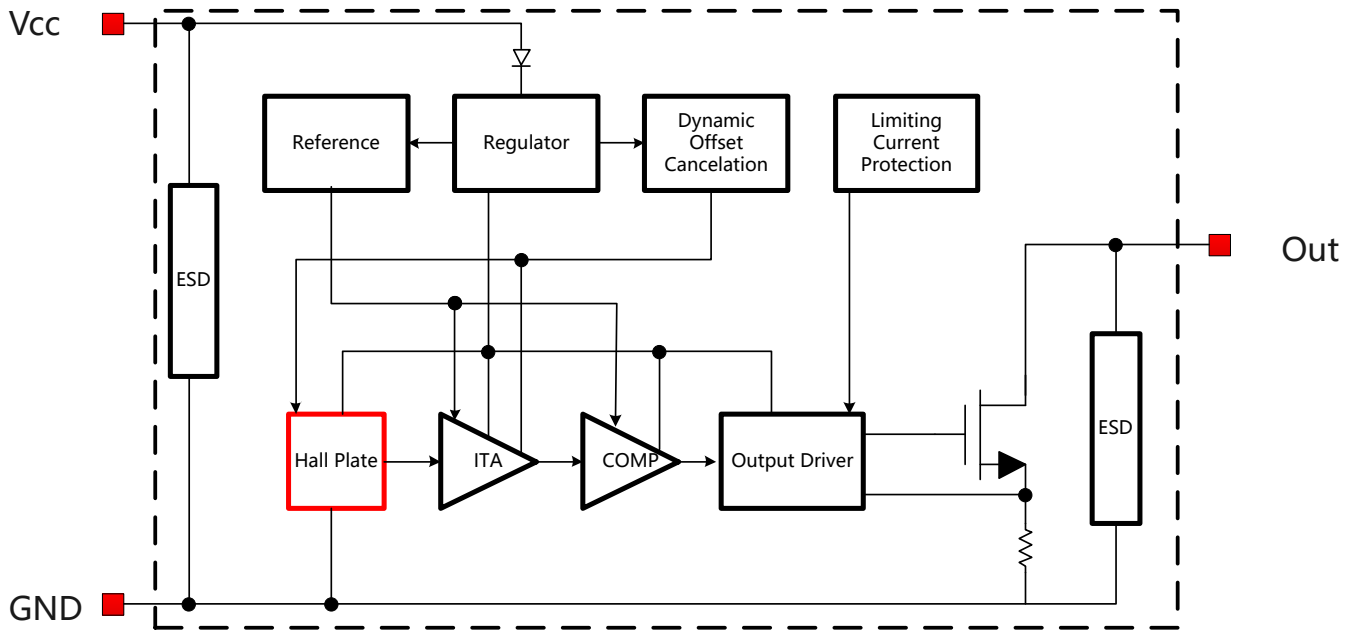

Figure.5 Functional Block Diagram

10 Electrical and Magnetic Characteristics

10.1 Absolute Maximum Ratings

Absolute maximum ratings are limited values to be applied individually, and beyond which the serviceability of the circuit may be impaired. Functional operability is not necessarily implied. Exposure to absolute maximum rating conditions for an extended period of time may affect device reliability.

Symbol	Parameters	Min	Max	Units
VCC	Supply Voltage	-	27	V
VRCC	Reverse Battery Voltage	-27	-	V
VOUT	Output Voltage	-	27	V
IOUT	Continuous Output Current	-	50	mA
TA	Operating Ambient Temperature	-40	150	°C
TS	Storage Temperature	-50	150	°C
TJ	Junction Temperature	-	165	°C
B	Magnetic Flux Density	No Limit		Gs

10.2 Electrical Specifications

At $T_A = -40 \sim 150 \text{ }^\circ\text{C}$, $V_{CC} = 2.8\text{V} \sim 24\text{V}$ (unless otherwise specified)

Symbol	Parameters	Test Condition	Min	Typ	Max	Unit
V_{CC}	Supply Voltage	Operating	2.8	-	24	V
I_{CC}	Supply Current	$B < B_{OP}$	-	3.50	6	mA
I_{OCP}	Short Circuit Protection Current	$B > B_{OP}$, $V_{OUT} = V_{CC}$	-	50	-	mA
V_{DSON}	Output Saturation Voltage	$I_{OUT} = 20\text{mA}$, $B > B_{OP}$	-	-	0.4	V
I_{OFF}	Output Leakage Current	$V_{OUT} = 24\text{V}$	-	-	10	μA
T_R	Output Rise Time	$R_L = 1\text{K}\Omega$, $C_L = 20\text{pF}$	-	-	1.0	μs
T_F	Output Fall Time	$R_L = 1\text{K}\Omega$, $C_L = 20\text{pF}$	-	-	1.0	μs
T_{PO}	Power on Time	$dV_{CC}/dt > 5\text{V}/\mu\text{s}$ $B > B_{OP(MAX)}$	-	-	10	μs
F_C	Chopping Frequency		-	800	-	KHz
F_S	Sampling Frequency		-	400	-	KHz
R_{TH}	Thermal Resistance of SOT-23		-	301	-	$^\circ\text{C}/\text{W}$
	Thermal Resistance of SOT-23 (Thin Outline)		-	301	-	$^\circ\text{C}/\text{W}$
	Thermal Resistance of TO-92		-	230	-	$^\circ\text{C}/\text{W}$

10.3 Magnetic Characteristics

At $V_{CC} = 2.8\text{V} \sim 24\text{V}$ (unless otherwise specified)

Part No.	Symbol	Min	Typ	Max	Unit
MT8161 Series	B_{OP} , $T_A = 25^\circ\text{C}$	10	20	30	Gs
	B_{RP} , $T_A = 25^\circ\text{C}$	-30	-20	-10	Gs
	B_{HYST} , $T_A = 25^\circ\text{C}$	20	40	60	Gs
MT8162 Series	B_{OP} , $T_A = 25^\circ\text{C}$	40	60	80	Gs
	B_{RP} , $T_A = 25^\circ\text{C}$	-80	-60	-40	Gs
	B_{HYST} , $T_A = 25^\circ\text{C}$	80	120	160	Gs

10.4 ESD Ratings

Symbol	Reference	Values	Unit	
V_{ESD}	Human-body model (HBM)	AEC-Q100-002	± 5500	V
	Charged-device model (CDM)	AEC-Q100-011	± 1000	V

10.5 Characteristic Performance

At Vcc=5V

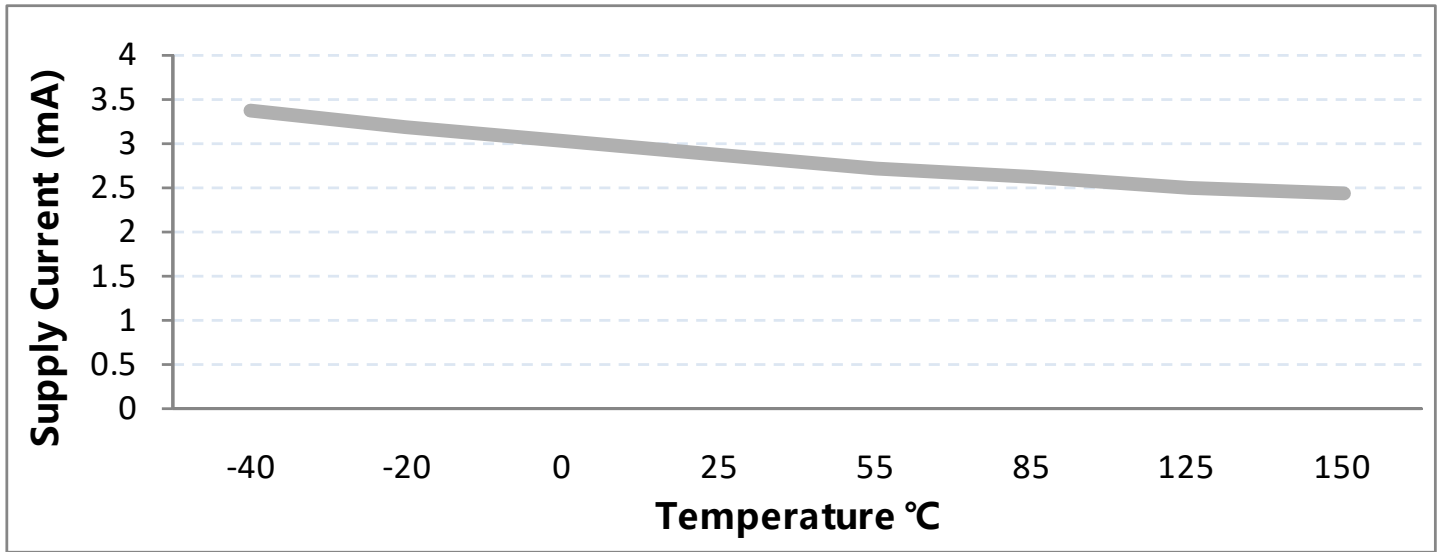
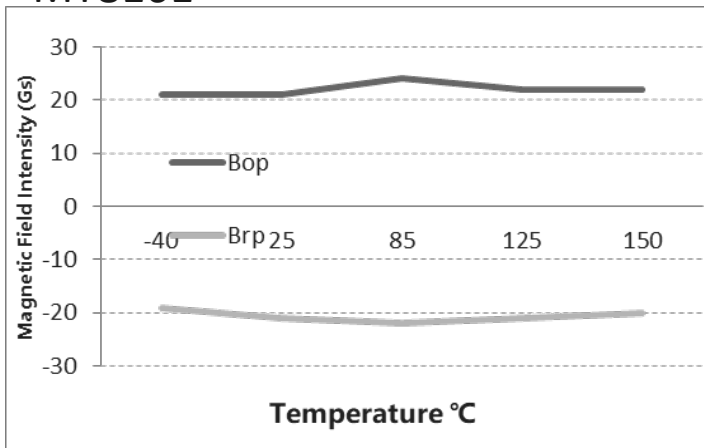

Figure.6 Supply Current vs. Temperature

MT8161



MT8162

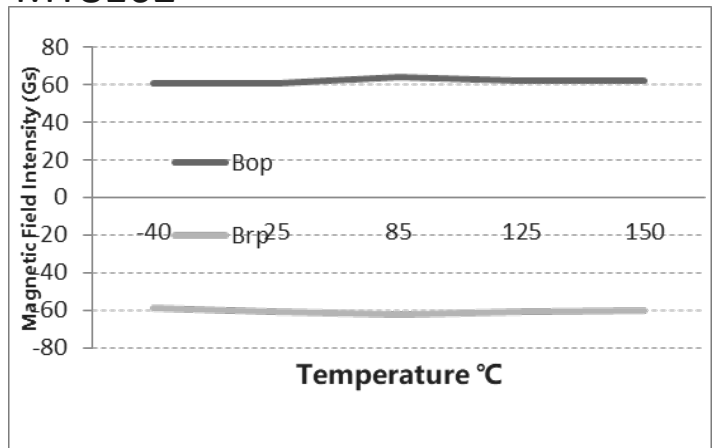
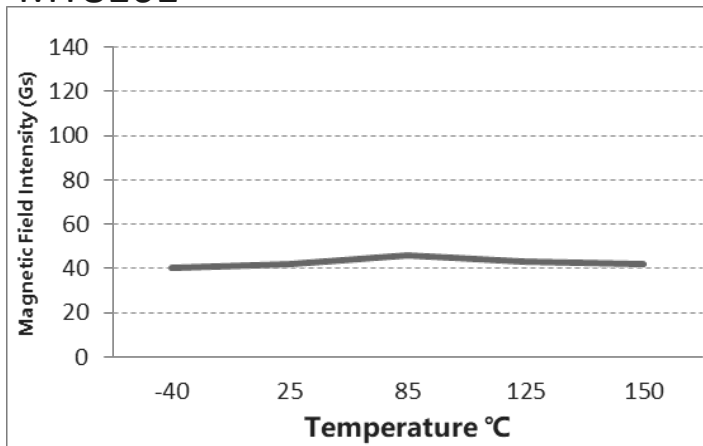

Figure.7 Magnetic Characteristics vs. Temperature (BOP & BRP)

MT8161



MT8162

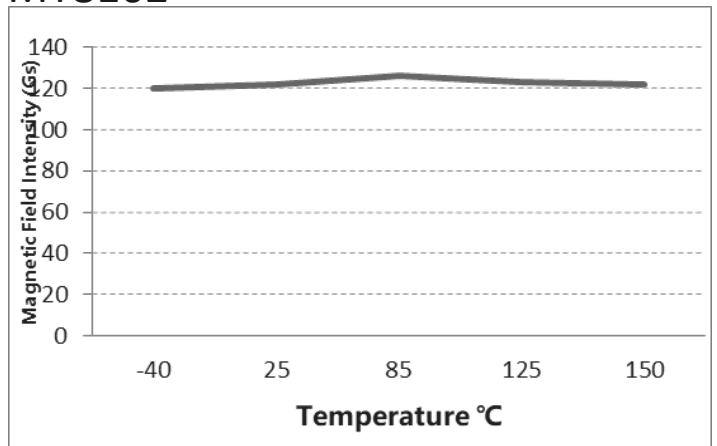

Figure.8 Magnetic Characteristics vs. Temperature (BHYST)

10.6 Typical Output Waveform

MT8161A as example

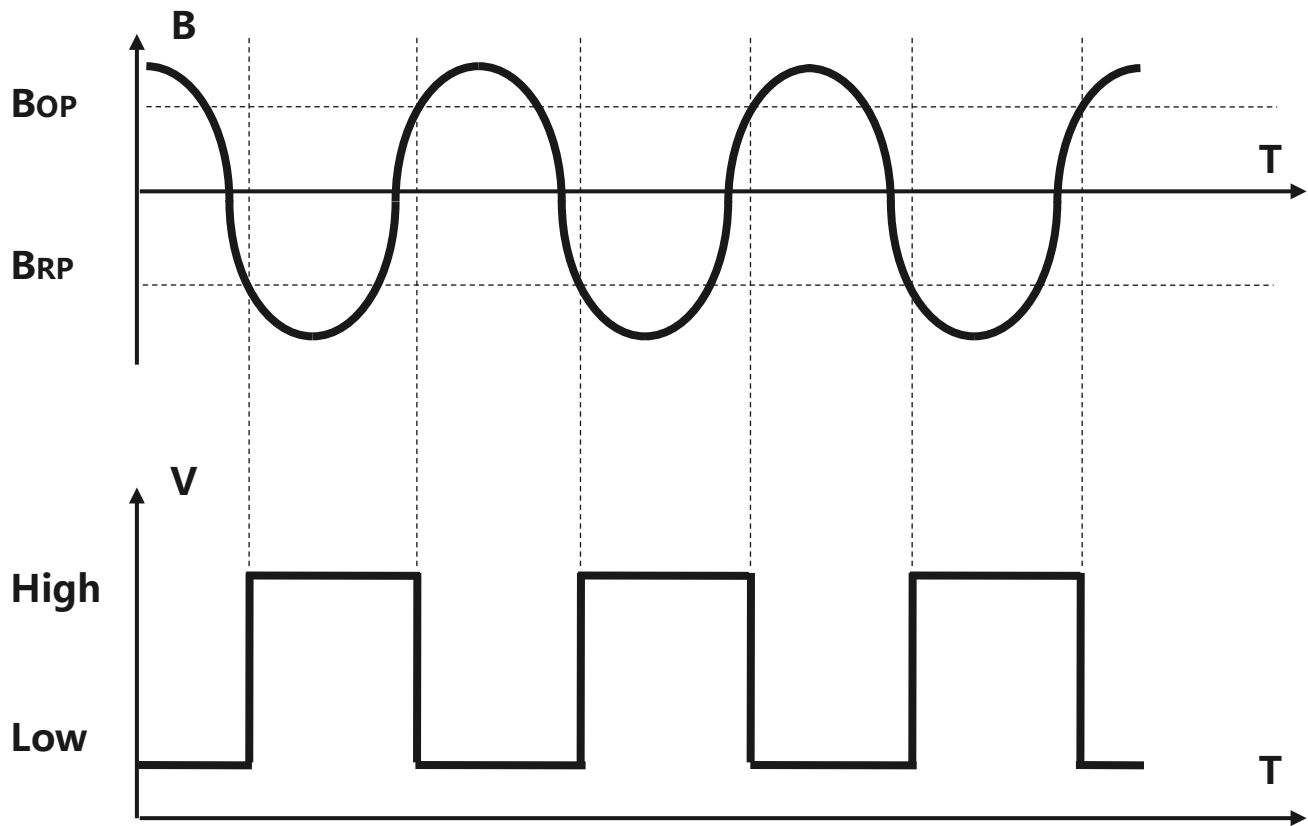

Figure.9 Digital Output vs. Magnetic Flux Density

11 Typical Application Circuit

MT8161AT as example

Note: Recommended value for R_L is 1KOhms to 10KOhms

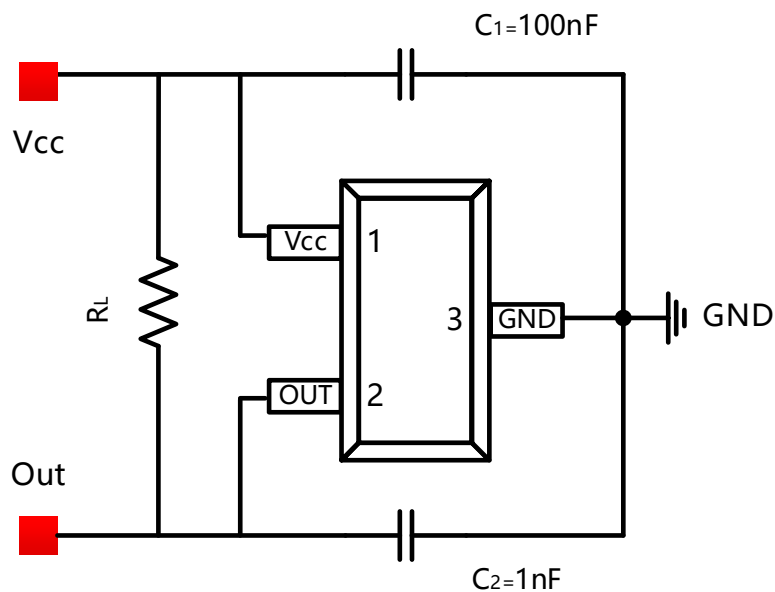

Figure.10 Typical Application Circuit

12 Package Material Information (For Reference Only – Not for Tooling Use)

12.1 SOT-23 Package Information

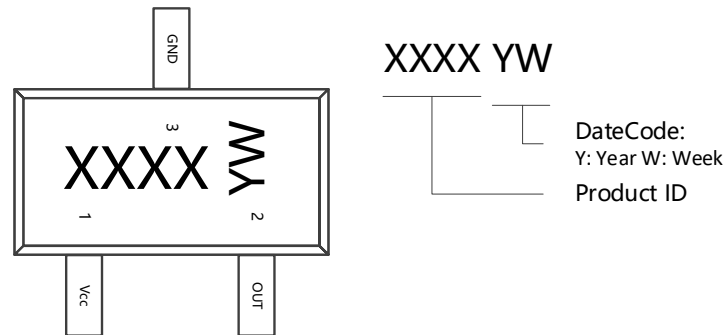

Figure.11 SOT-23 Chip Marking Spec

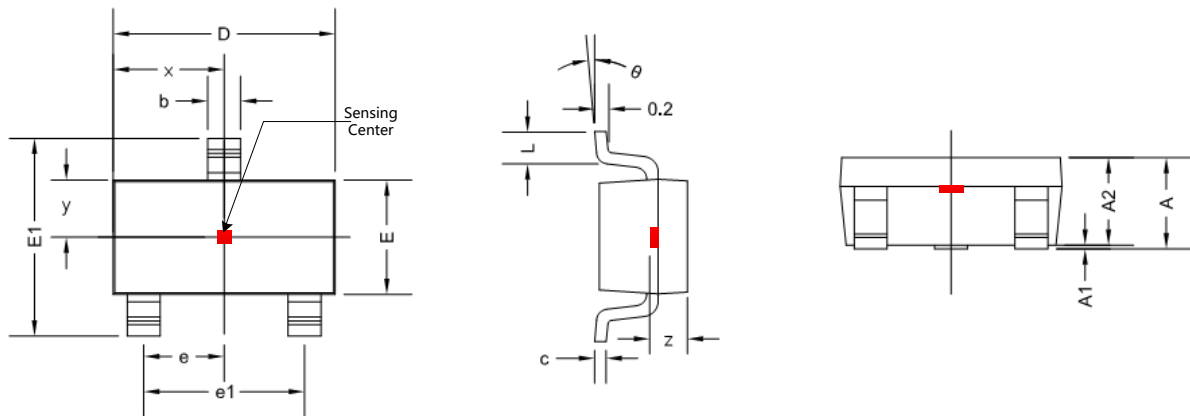

Figure.12 SOT-23 Package Drawing

Symbol	Dimensions in Millimeters		Dimensions in Inches	
	Min	Max	Min	Max
A	1.050	1.300	0.041	0.051
A1	0.000	0.150	0.000	0.006
A2	1.000	1.200	0.039	0.047
b	0.300	0.500	0.012	0.020
c	0.080	0.220	0.003	0.009
D	2.800	3.020	0.110	0.119
E	1.500	1.700	0.059	0.067
E1	2.600	3.000	0.102	0.118
e	0.950 TYP		0.037 TYP	
e1	1.800	2.000	0.071	0.079
L	0.300	0.600	0.012	0.024
θ	0 °	8 °	0 °	8 °
x	1.460 TYP		0.057 TYP	
y	0.800 TYP		0.032 TYP	
z	0.600 TYP		0.024 TYP	

12.2 SOT-23 (Thin Outline) Package Information

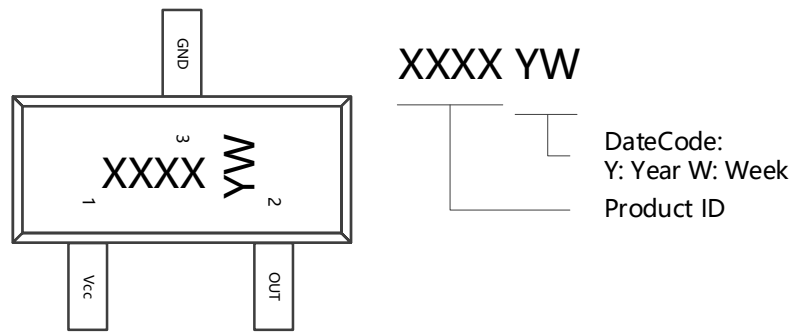

Figure.13 SOT-23 (Thin Outline) Chip Marking Spec

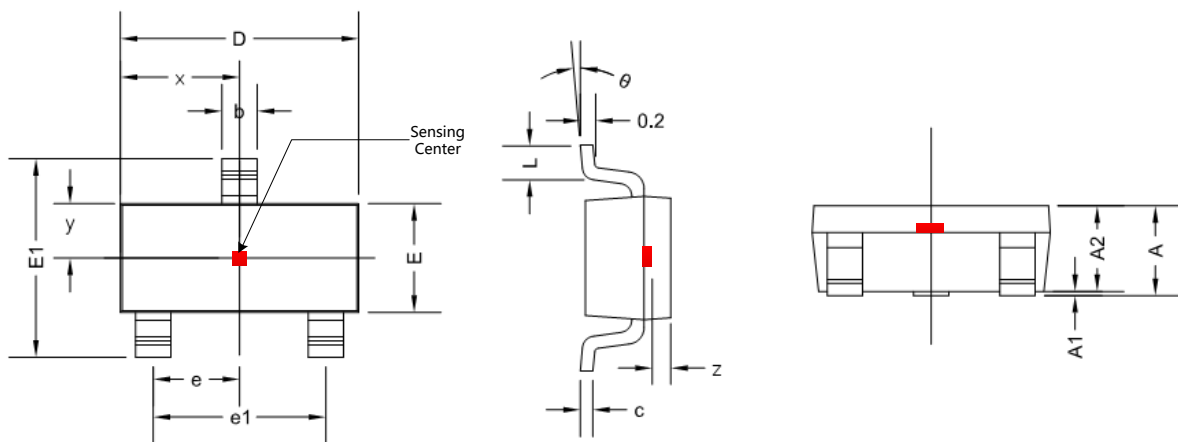

Figure.14 SOT-23 (Thin Outline) Package Drawing

Symbol	Dimensions in Millimeters		Dimensions in Inches	
	Min	Max	Min	Max
A	0.900	1.150	0.035	0.045
A1	0.000	0.100	0.000	0.004
A2	0.900	1.100	0.035	0.043
b	0.300	0.500	0.012	0.020
c	0.132	0.202	0.005	0.008
D	2.800	3.000	0.110	0.118
E	1.200	1.400	0.047	0.055
E1	2.250	2.550	0.089	0.100
e	0.950 TYP		0.037 TYP	
e1	1.800	2.000	0.071	0.079
L	0.550 REF		0.022 REF	
L1	0.300	0.500	0.012	0.020
θ	0 °	8 °	0 °	8 °
x	1.460 TYP		0.057 TYP	
y	0.650 TYP		0.026 TYP	
z	0.500 TYP		0.020 TYP	

12.3 Flat TO-92 Package Information

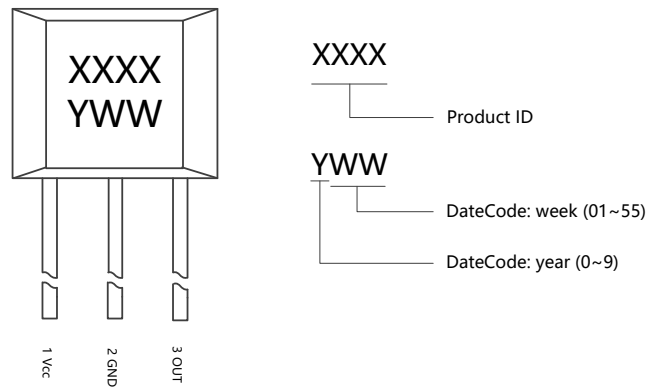

Figure.15 Flat TO-92 Chip Marking Spec

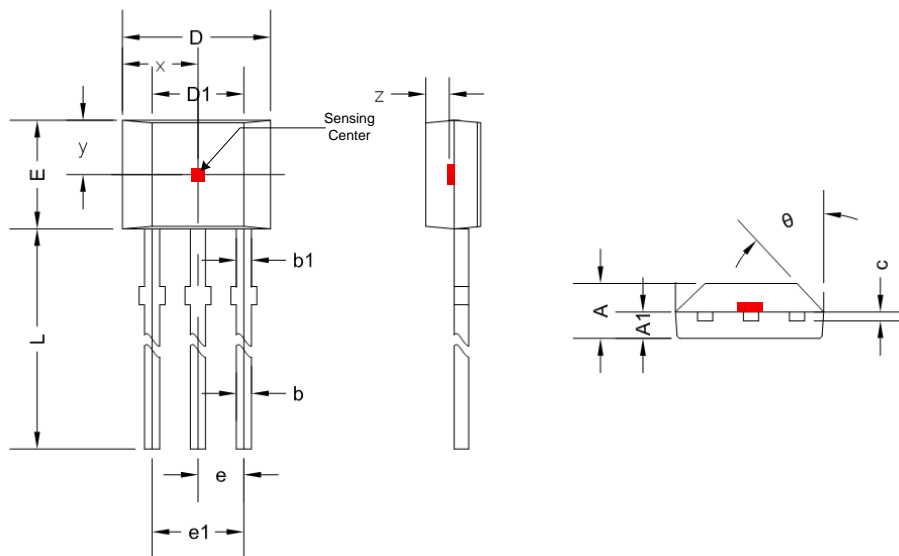

Figure.16 Flat TO-92 Package Drawing

Symbol	Dimensions in Millimeters		Dimensions in Inches	
	Min	Max	Min	Max
A	1.420	1.620	0.056	0.064
A1	0.660	0.910	0.026	0.036
b	0.330	0.560	0.013	0.022
b1	0.400	0.510	0.016	0.020
c	0.330	0.510	0.013	0.020
D	3.900	4.200	0.154	0.165
D1	2.280	2.680	0.090	0.106
E	2.900	3.280	0.114	0.128
e	1.270 TYP		0.050 TYP	
e1	2.440	2.640	0.096	0.104
L	13.500	16.200	0.531	0.638
θ	45 ° TYP		45 ° TYP	
x	2.025 TYP		0.080 TYP	
y	1.545 TYP		0.061 TYP	
z	0.500 TYP		0.020 TYP	

12.4 WLCSP Package Information

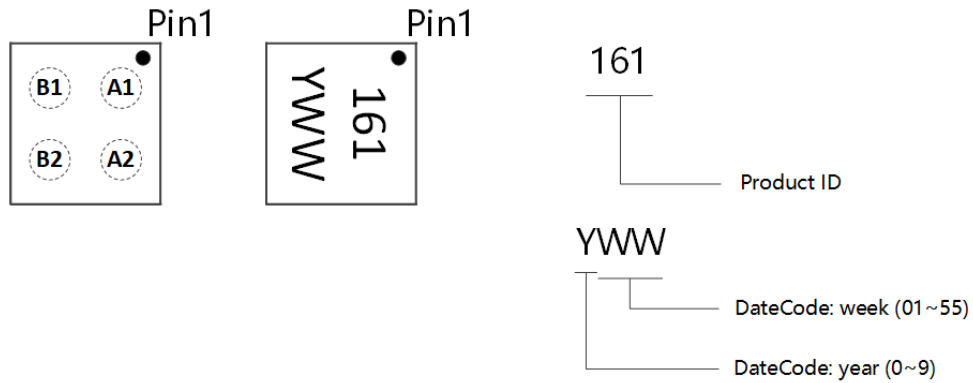

Figure.17 WLCSP Chip Marking Spec (Top View)

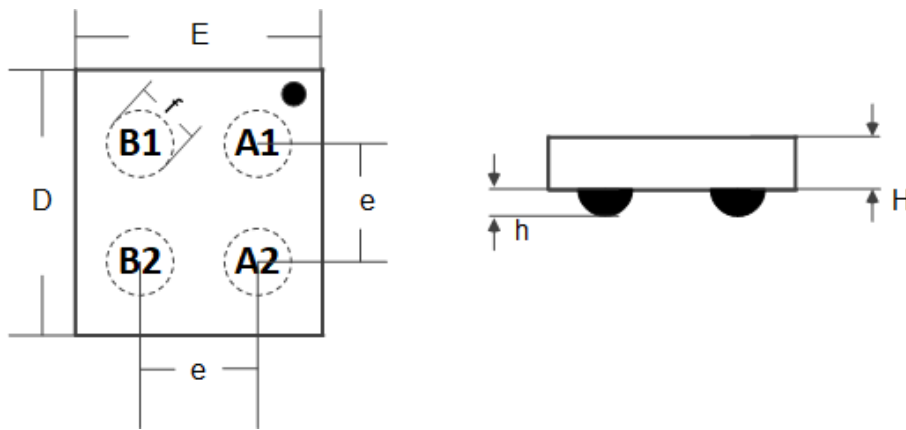

Figure18 WLCSP Package Drawing

Symbol	Dimensions in Millimeters		Dimensions in Inches	
	Min	Max	Min	Max
E	0.745	0.795	0.030	0.032
D	0.775	0.825	0.031	0.033
e	0.400 TYP		0.016 TYP	
f	0.200 TYP		0.008 TYP	
H	0.312	0.368	0.012	0.015
h	0.060 TYP		0.002 TYP	

13 Copy Rights and Disclaimer

1. This document may not be reproduced or duplicated, in any form, in whole or in part without prior written consent of MagnTek . Copyrights © 2019, MagnTek Incorporated.
2. MagnTek reserves the right to make changes to the information published in this document at anytime without notice.
3. MagnTek' s products are limited for use in normal commercial applications. MagnTek' s products are not to be used in any device or system, including but not limited to medical life support equipment and system.

For the latest version of this document, please visit our website: www.magntek.com.cn

单击下面可查看定价，库存，交付和生命周期等信息

[>>Magntek\(麦歌恩\)](#)