

Omni-polar, High Voltage & Low Power Consumption Hall-Effect Switch IC

1 Product Description

The MT855X family is produced by BCD technology with both high performance and high reliability. The Hall IC internally includes an on-chip Hall voltage generator, a voltage regulator for operation with supply voltage of 3.0V to 30V, temperature compensation circuitry, small-signal amplifier, Hall IC with dynamic offset cancellation system, Schmitt trigger and open drain output. It also includes an clamp diode at output and reversed power supply protection enhances the robustness of Hall IC.

The product responds to either North pole or South pole magnetic fields. The output will be turned on (Low) when the magnetic flux density (B) is larger than the operating point (BOP), and be turned off (High) when the magnetic flux density (B) is lower than the releasing point (BRP).

The MT855X family provides a variety of packages to customers: SOT-23/SOT-23 (Thin Outline) for surface mount and flat TO-92 for through-hole mount. All packages are RoHS compliant.

2 Feature

- BCD Technology
- Omni-polar Switch
- 3.0~30V Operating Vcc Range
- -40°C~125°C Operating Temperature
- Package Option:
Flat TO-92
SOT-23
SOT-23 (Thin Outline)
- Magnetic Sensitivity Option:
MT8551 (BOP=±32Gs, BRP=±27Gs)
- Open Drain Output
- -24V Reversed Power Supply Protection
- Output Limiting Current Protection
- RoHS Compliant: 2011/65/EU

3 Product Overview of MT855X

Part No.	Description
MT855XA	Flat TO-92, bulk packaging (1000pcs/bag)
MT855XAT	SOT-23, tape & reel (3000pcs/bag)
MT855XET	SOT-23 (Thin Outline), tape & reel (3000pcs/bag)

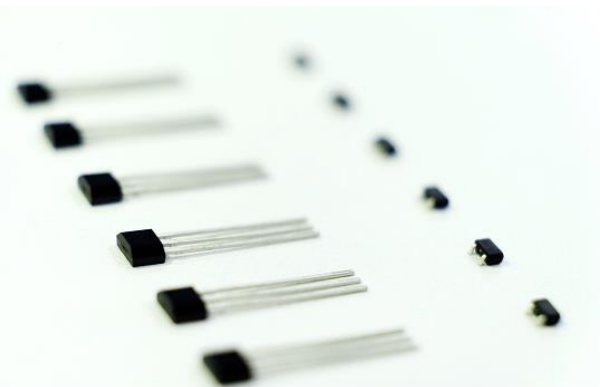

4 Applications

- Home appliances, Industrial
- Position Detection
- Magnetic Encoder
- Proximity Switch

5. Pin Configuration and Functions

	Vcc	Out	GND
SOT-23	1	2	3
SOT-23 (Thin Outline)	1	2	3
Flat TO-92	1	3	2
Description	Power	Open Drain	Ground

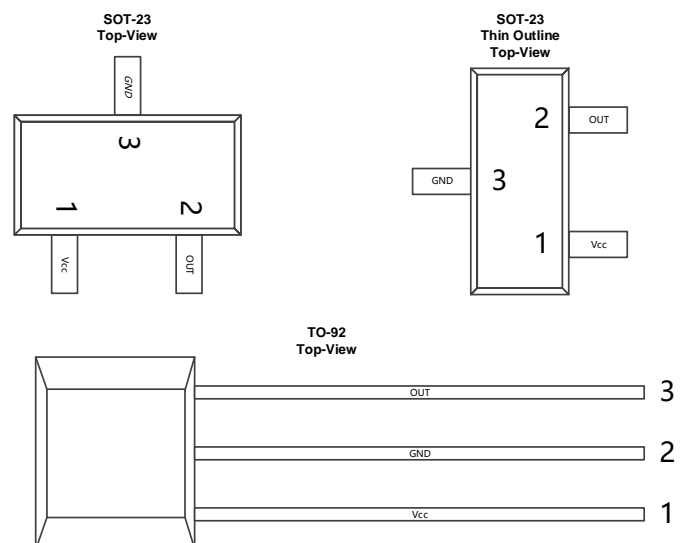

Figure.1 Pin Configuration & Functions

Table of Contents

1	Product Description.....	1
2	Feature.....	1
3	Product Overview of MT855X	1
4	Applications.....	1
5	Pin Configuration and Functions.....	1
6	Definition of Switching Function.....	3
7	Function Description.....	3
8	Feature Description.....	3
9	Functional Block Diagram.....	4
10	Electrical and Magnetic Characteristics.....	4
	10.1 Absolute Maximum Ratings.....	4
	10.2 Electrical Specifications.....	5
	10.3 Magnetic Characteristics.....	5
	10.4 ESD Ratings.....	5
	10.5 Characteristic Performance.....	6
	10.6 Typical Output Waveform.....	7
11	Typical Application Circuit.....	7
12	Package Material Information.....	8
	12.1 SOT-23 Package Information.....	8
	12.2 SOT-23 (Thin Outline) Package Information.....	9
	12.3 Flat TO-92 Package Information.....	10

Reversion History

- 1 Originally Version

6 Definition of Switching Function

Figure.2 shows the device functionality and hysteresis

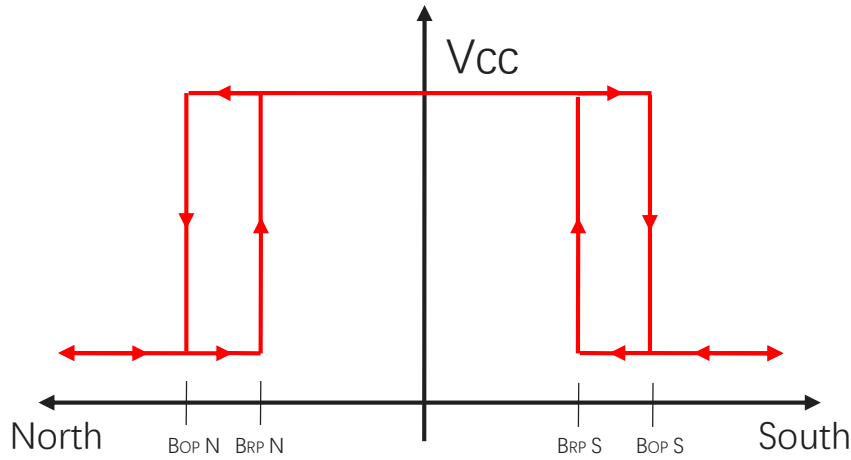

Figure.2 Omni-polar Switching Function

7 Function Description

B_{OP}: Operating Point, Magnetic flux density applied on the branded side of the package which turns the output driver ON ($V_{OUT}=Low$)

B_{RP}: Releasing Point, Magnetic flux density applied on the branded side of the package which turns the output driver OFF ($V_{OUT}=High$)

B_{HYST}: Hysteresis Window, $|B_{OP} - B_{RP}|$

Devices that have a lower magnetic threshold ($V_{OUT}=High$) detect magnets at a farther distance. Higher thresholds ($V_{OUT}=Low$) generally require a closer distance or larger magnet.

8 Feature Description

The MT855X device is sensitive to the magnetic field component that is perpendicular to the top of the package

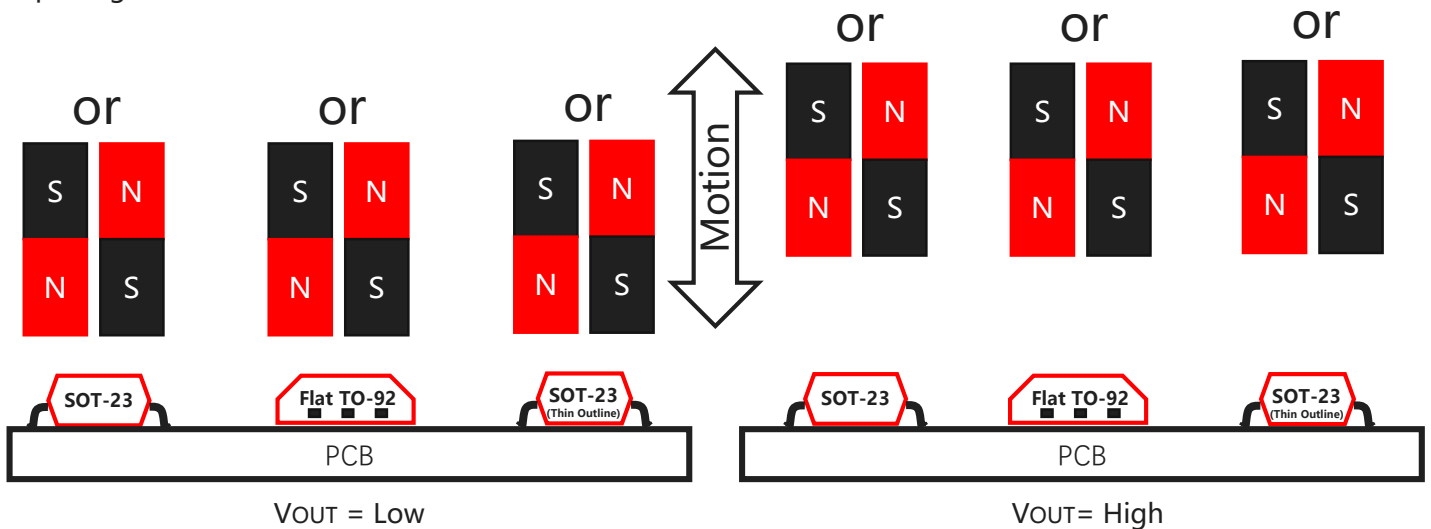

Figure.3 Flux Direction Polarity

9 Functional Block Diagram

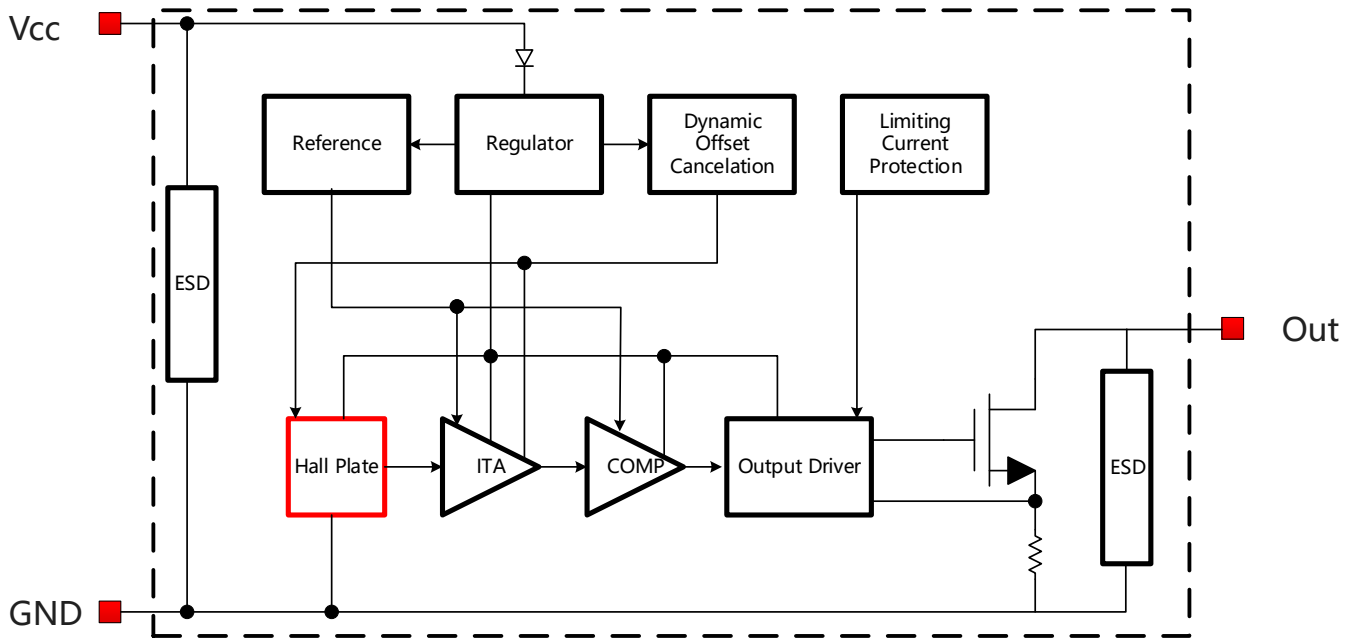

Figure.4 Functional Block Diagram

10 Electrical and Magnetic Characteristics

10.1 Absolute Maximum Ratings

Absolute maximum ratings are limited values to be applied individually, and beyond which the serviceability of the circuit may be impaired. Functional operability is not necessarily implied. Exposure to absolute maximum rating conditions for an extended period of time may affect device reliability.

Symbol	Parameters	Min	Max	Units
VCC	Supply Voltage	-	34	V
VRCC	Reverse Battery Voltage	-24	-	V
VOUT	Output Voltage	-	34	V
IOUT	Continuous Output Current	-	55	mA
TA	Operating Ambient Temperature	-40	125	°C
TS	Storage Temperature	-50	150	°C
TJ	Junction Temperature	-	165	°C
B	Magnetic Flux Density	No Limit		Gs

10.2 Electrical Specifications

At $T_A = -40 \sim 125$ °C, $V_{CC} = 3.0V \sim 30V$ (unless otherwise specified)

Symbol	Parameters	Test Condition	Min	Typ	Max	Unit
V_{CC}	Supply Voltage	Operating	3.0	-	30	V
I_{CC}	Supply Current	$ B < B_{RP} $	-	1	1.5	mA
I_{OCP}	Short Circuit Protection Current	$ B > B_{OP} $, $V_{OUT} = V_{CC}$	-	50	-	mA
V_{DSON}	Output Saturation Voltage	$I_{OUT} = 20mA$, $ B > B_{OP} $	-	-	0.4	V
I_{OFF}	Output Leakage Current	$V_{OUT} = 24V$, $ B < B_{RP} $	-	-	10	uA
T_R	Output Rise Time	$C_L = 20pF$	-	-	1.0	us
T_F	Output Fall Time	$C_L = 20pF$	-	-	1.0	us
T_{PO}	Power on Time	$dV_{CC}/dt > 5V/uS$ $ B > B_{OP} $ (MAX)	-	-	15	us
F_C	Chopping Frequency		-	400	-	KHz
F_S	Sampling Frequency		-	25	-	KHz
R_{TH}	Thermal Resistance of SOT-23		-	301	-	°C/W
	Thermal Resistance of SOT-23 (Thin Outline)		-	301	-	°C/W
	Thermal Resistance of TO-92		-	230	-	°C/W

10.3 Magnetic Characteristics

At $V_{CC} = 3.0V \sim 30V$ (unless otherwise specified)

Part No.	Symbol	Min	Typ	Max	Unit
MT8551 Series	B_{OP} , $T_A = 25^\circ C$	-	± 32	-	Gs
	B_{RP} , $T_A = 25^\circ C$	-	± 27	-	Gs
	B_{HYST} , $T_A = 25^\circ C$	-	5	-	Gs

10.4 ESD Ratings

Symbol	Reference	Values	Unit
V_{ESD}	Human-body model (HBM)	AEC-Q100-002	Class II Grade
	Charged-device model (CDM)	AEC-Q100-011	± 1000 V

10.5 Characteristic Performance

At $V_{CC}=5V$

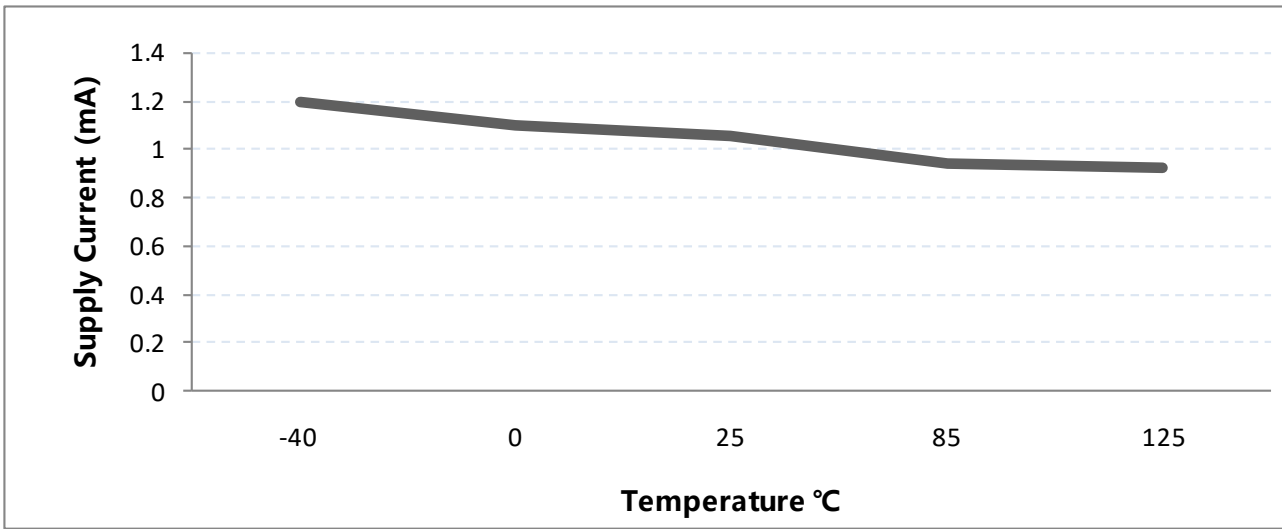

Figure.5 Supply Current vs. Temperature

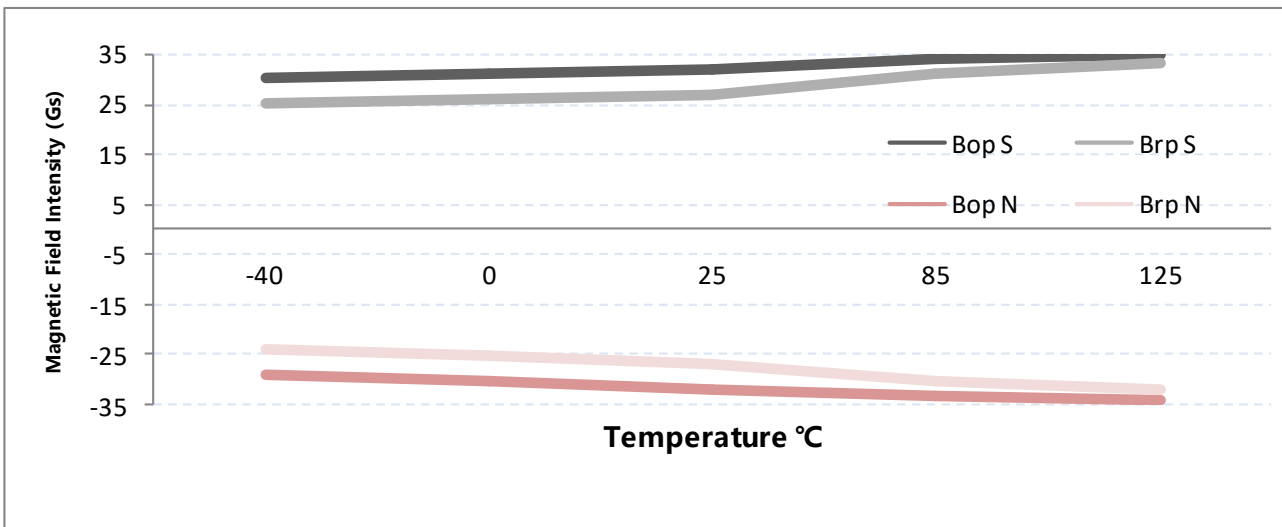

Figure.6 Magnetic Characteristics vs. Temperature (BOP & BRP)

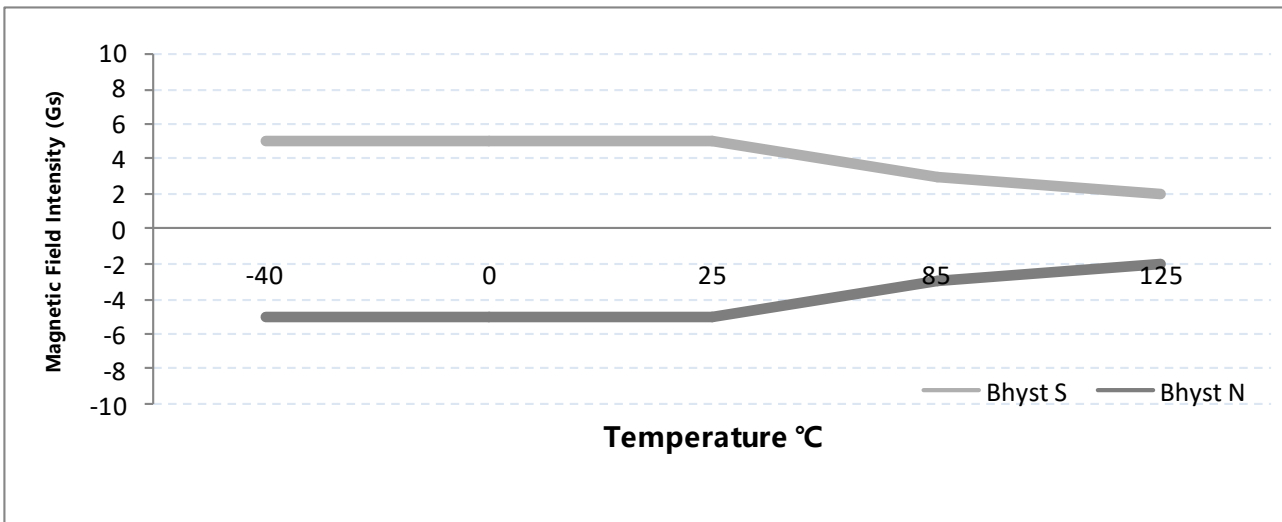

Figure.7 Magnetic Characteristics vs. Temperature (BHYST)

10.6 Typical Output Waveform

MT8551A as example

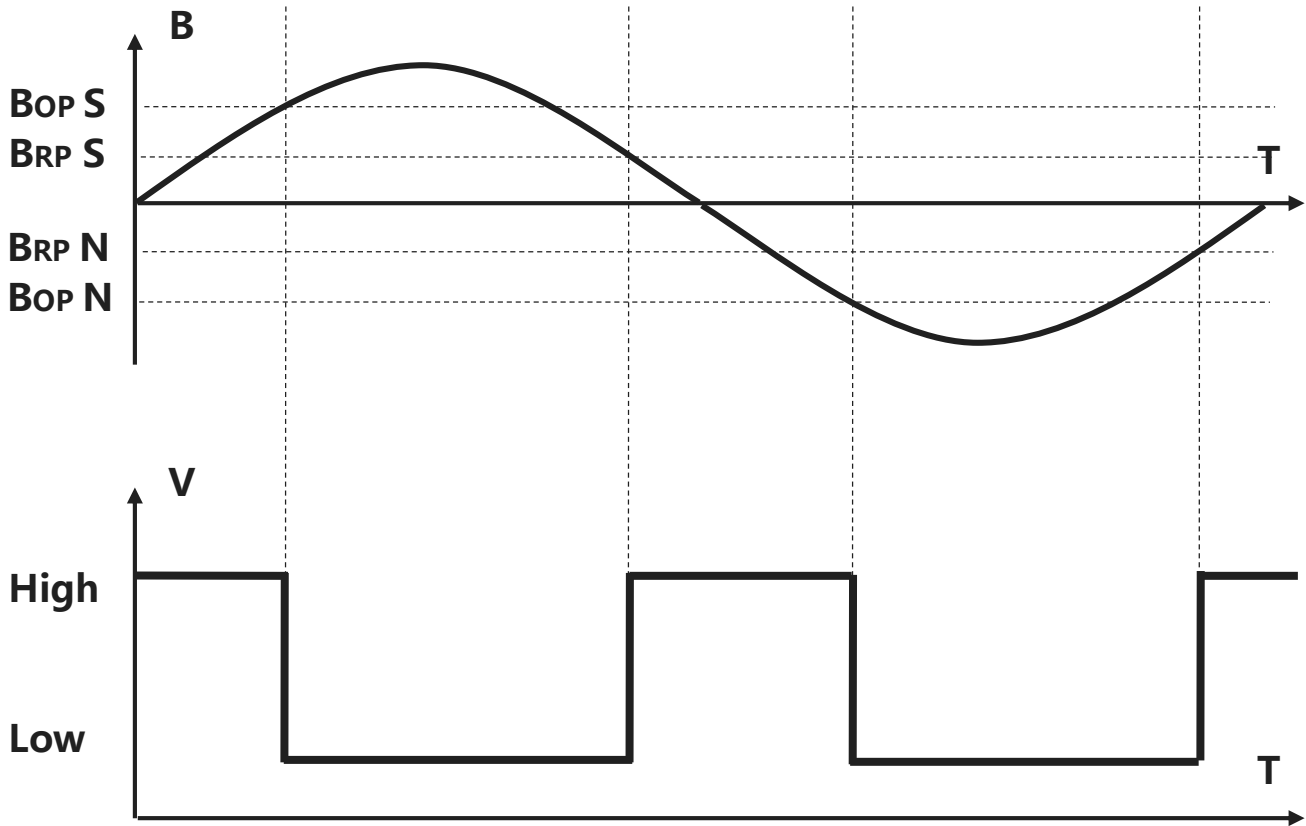

Figure.8 Digital Output vs. Magnetic Flux Density

11 Typical Application Circuit

MT8551AT as example

Note: Recommended value for R_L is 10KOhms

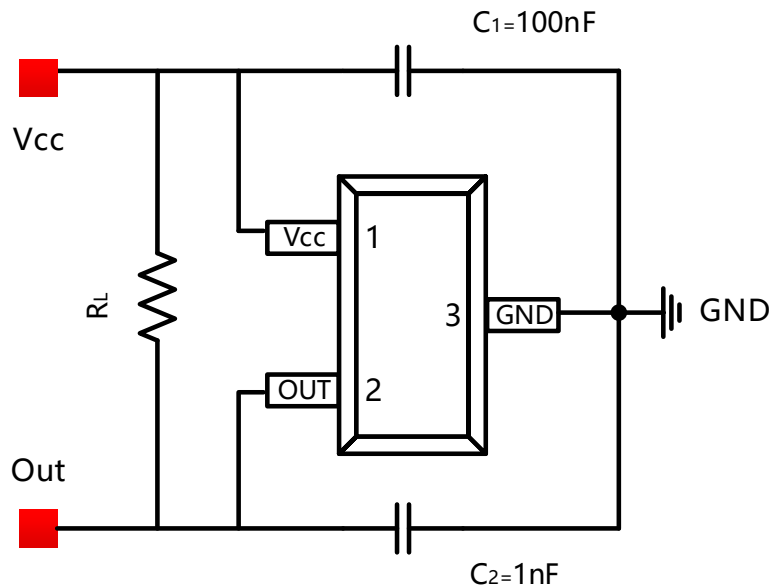

Figure.9 Typical Application Circuit

12 Package Material Information (For Reference Only – Not for Tooling Use)

12.1 SOT-23 Package Information

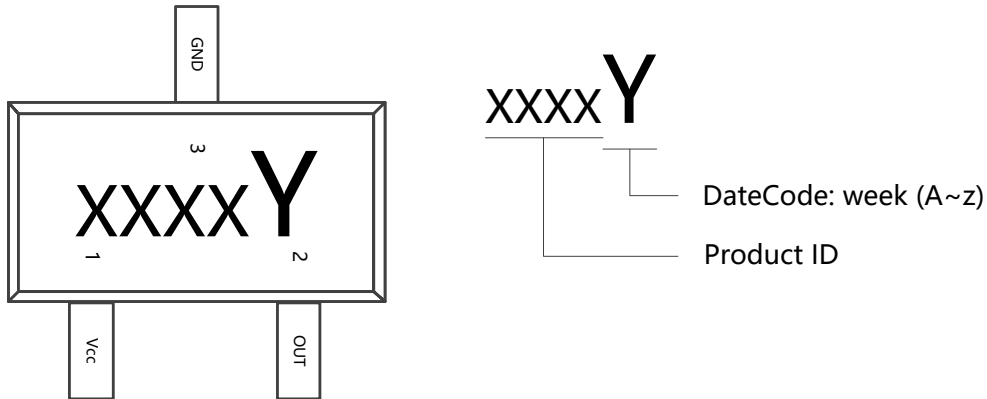

Figure.10 SOT-23 Chip Marking Spec

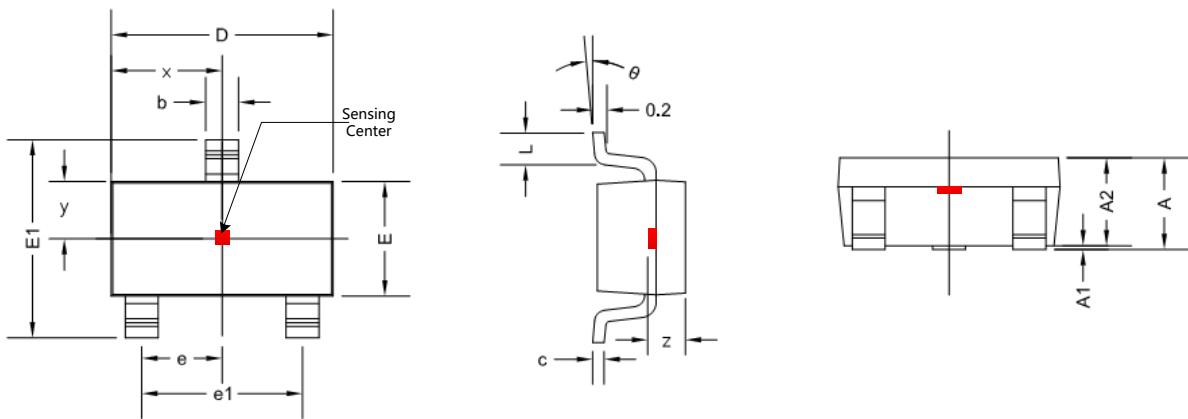

Figure.11 SOT-23 Package Drawing

Symbol	Dimensions in Millimeters		Dimensions in Inches	
	Min	Max	Min	Max
A	1.050	1.250	0.041	0.049
A1	0.000	0.100	0.000	0.004
A2	1.050	1.150	0.041	0.045
b	0.300	0.500	0.012	0.020
c	0.100	0.200	0.004	0.008
D	2.820	3.020	0.111	0.119
E	1.500	1.700	0.059	0.067
E1	2.650	2.950	0.104	0.116
e	0.950 TYP		0.037 TYP	
e1	1.800	2.000	0.071	0.079
L	0.300	0.600	0.012	0.024
θ	0 °	8 °	0 °	8 °
x	1.460 TYP		0.057 TYP	
y	0.800 TYP		0.032 TYP	
z	0.600 TYP		0.024 TYP	

12.2 SOT-23 (Thin Outline) Package Information

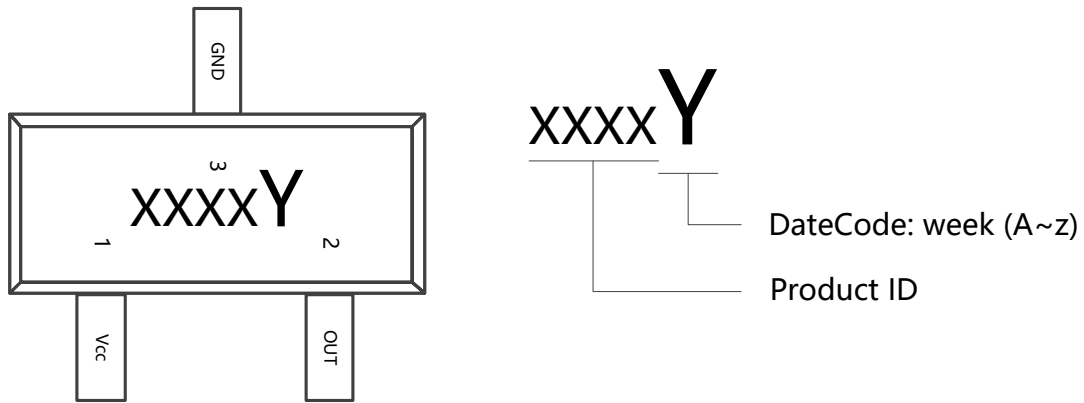

Figure.12 SOT-23 (Thin Outline) Chip Marking Spec

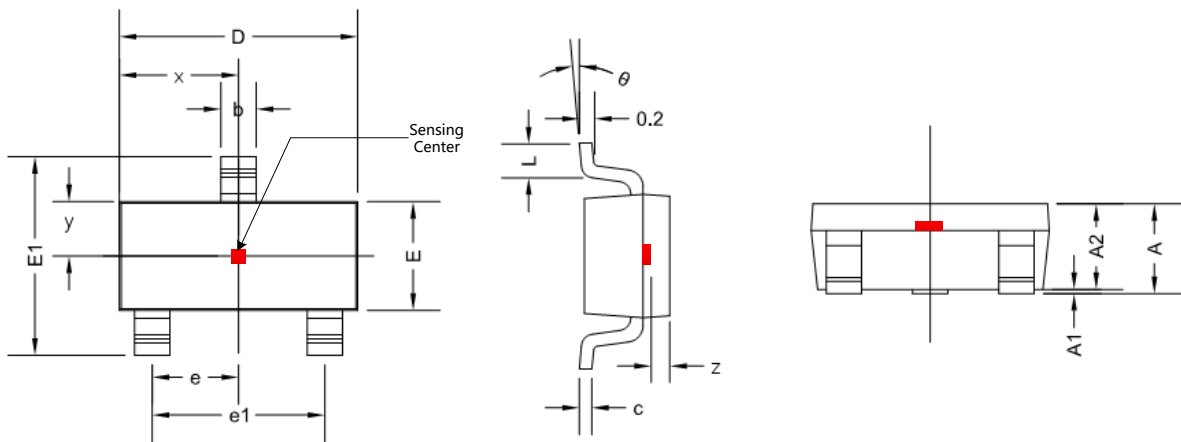

Figure.13 SOT-23 (Thin Outline) Package Drawing

Symbol	Dimensions in Millimeters		Dimensions in Inches	
	Min	Max	Min	Max
A	0.900	1.150	0.035	0.045
A1	0.000	0.100	0.000	0.004
A2	0.900	1.050	0.035	0.041
b	0.300	0.500	0.012	0.020
c	0.080	0.150	0.003	0.006
D	2.800	3.000	0.110	0.118
E	1.200	1.400	0.047	0.055
E1	2.250	2.550	0.089	0.100
e	0.950 TYP		0.037 TYP	
e1	1.800	2.000	0.071	0.079
L	0.550 REF		0.022 REF	
L1	0.300	0.500	0.012	0.020
θ	0 °	8 °	0 °	8 °
x	1.460 TYP		0.057 TYP	
y	0.650 TYP		0.026 TYP	
z	0.500 TYP		0.020 TYP	

12.3 Flat TO-92 Package Information

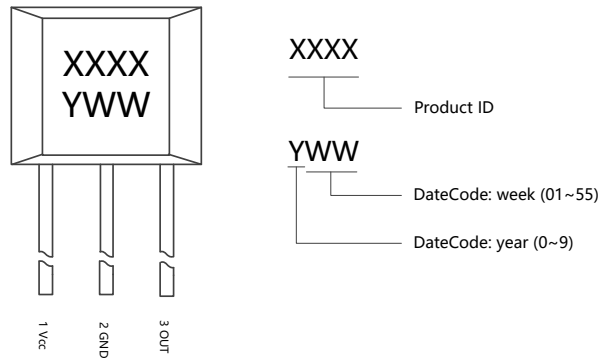

Figure.14 Flat TO-92 Chip Marking Spec

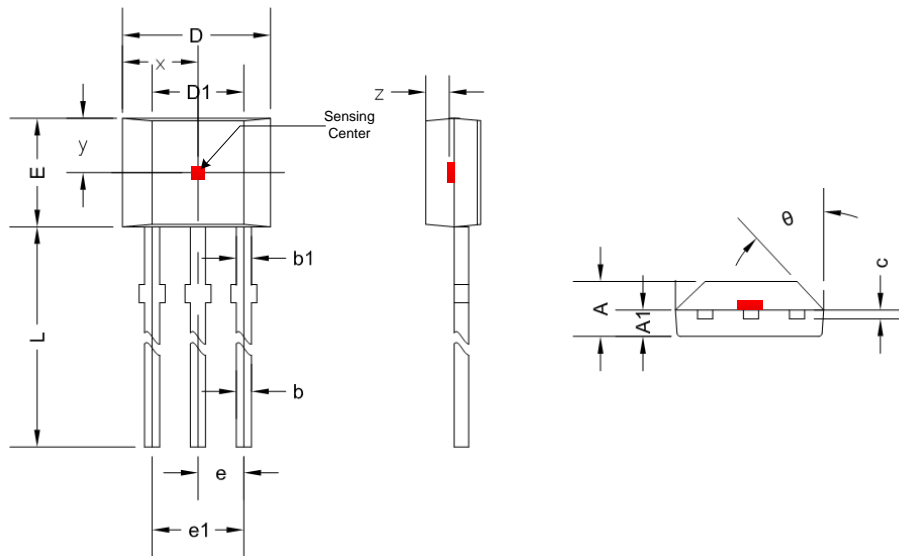

Figure.15 Flat TO-92 Package Drawing

Symbol	Dimensions in Millimeters		Dimensions in Inches	
	Min	Max	Min	Max
A	1.420	1.620	0.056	0.064
A1	0.660	0.860	0.026	0.034
b	0.350	0.480	0.013	0.019
b1	0.400	0.510	0.016	0.020
c	0.330	0.510	0.013	0.020
D	3.900	4.100	0.154	0.161
D1	2.280	2.680	0.090	0.106
E	3.050	3.250	0.120	0.128
e	1.270 TYP		0.050 TYP	
e1	2.440	2.640	0.096	0.104
L	14.350	14.750	0.565	0.581
θ	45 ° TYP		45 ° TYP	
x	2.025 TYP		0.080 TYP	
y	1.545 TYP		0.061 TYP	
z	0.500 TYP		0.020 TYP	

单击下面可查看定价，库存，交付和生命周期等信息

[>>Magntek\(麦歌恩\)](#)