

Features and Benefits

- **CMOS Technology**
- **Magnetic Type: Omni-polar**
- **Operating Voltage Range:**
Supply Voltage 2.2~5.5V
- **Specified Operating Temperature Range:**
From -40°C~85°C
- **High Magnetic Sensitivity**
 $B_{OP}=18\text{Gauss}$, $B_{RP}=10\text{Gauss}$ (South)
 $B_{OP}=-18\text{Gauss}$, $B_{RP}=-10\text{Gauss}$ (North)
- **Lower Power Consumption**
Average Supply Current <4uA (typical)
- **Lead Free Package**
Flat TO-92, SOT-23
- **High ESD Rating**
- **Internal 100K Pull-up Resistor**
- **RoHS Compliant**
2011/65/EU

Applications

- Smart meter
- Hand held Devices

Family Members

Part number	Description
MT1322A	Flat TO-92 package, bulk packaging (1000pcs/bag)
MT1322A-S	Flat TO-92 package, short leg, bulk packaging (1000pcs/bag)
MT1322A-T	Flat TO-92 package, radial lead, bulk packaging (1000pcs/bag)
MT1322A-TS	Flat TO-92 package, radial lead, short leg, bulk packaging (1000pcs/bag)
MT1322AT	SOT-23 package, tape and reel packaging (3000pcs/bag)

General Description

The MT1322 family, produced with CMOS technology. The Hall IC internally includes an on-chip Hall voltage generator, a voltage regulator for operation with supply voltages of 2.2 to 5.5V, sleep/awake logic for low power consumption, temperature compensation circuitry, small-signal amplifier, Hall sensor with dynamic offset cancellation system, Schmitt trigger and an output driver with a 100K pull-up resistor.

They are designed to respond to either a North pole or a South pole. While the magnetic flux density (B) is larger than operate point (B_{OP}), the output will be turned on (Low), While the magnetic flux density (B) is lower than release point (B_{RP}), then turn off (High).

The MT1322 family provides a variety of packages to customers: SOT-23 for surface mount and flat TO-92 for through-hole mount. All packages are RoHS compliant.

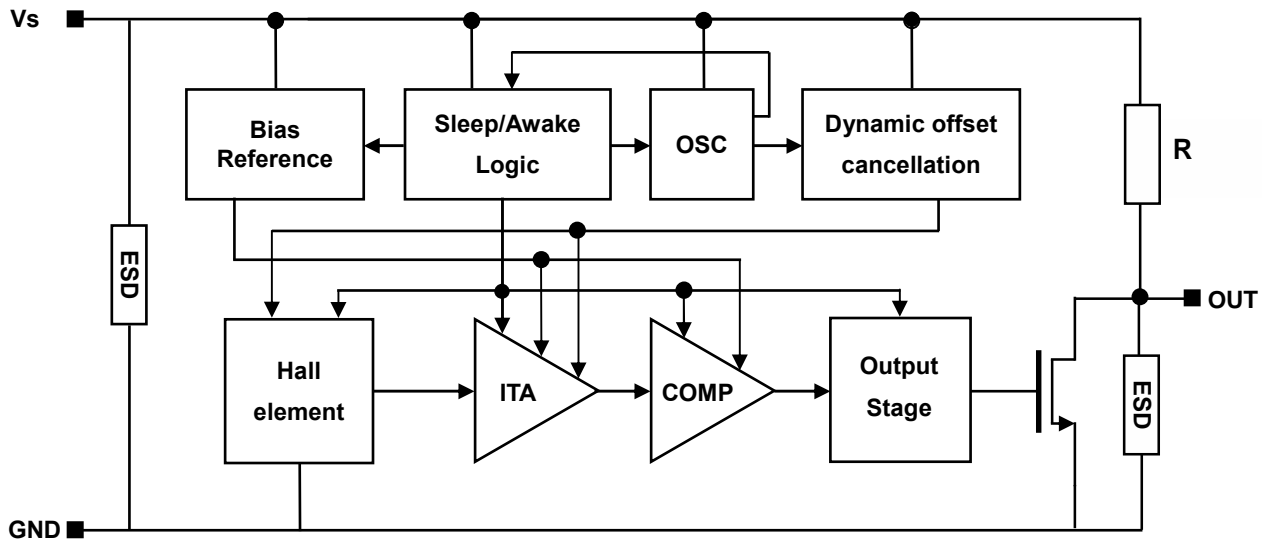

Functional Block Diagram

Function Description

Definition of Magnetic Parameters

B_{OP} : Operating Point, Magnetic flux density applied on the branded side of the package which turns the output driver ON ($V_{OUT}=Low$)

B_{RP} : Release Point, Magnetic flux density applied on the branded side of the package which turns the output driver OFF ($V_{OUT}=High$)

B_{HYST} : Hysteresis Window, $|B_{OP}-B_{RP}|$

Definition of Switching Function

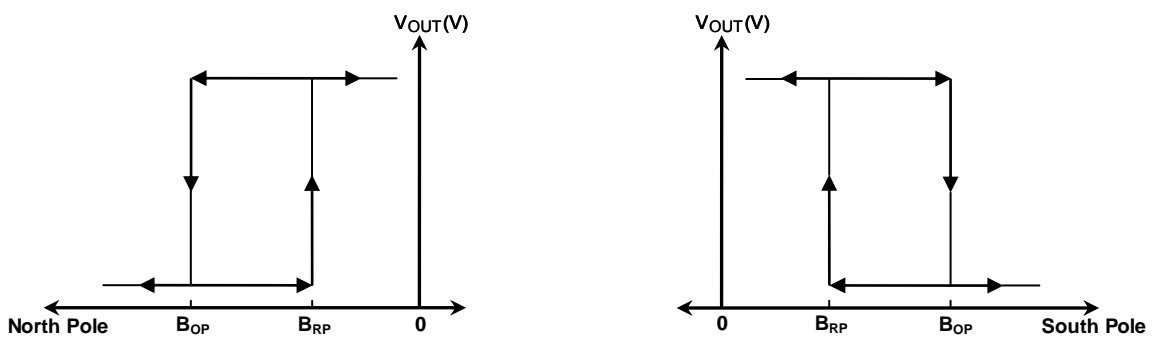

Switching Behavior

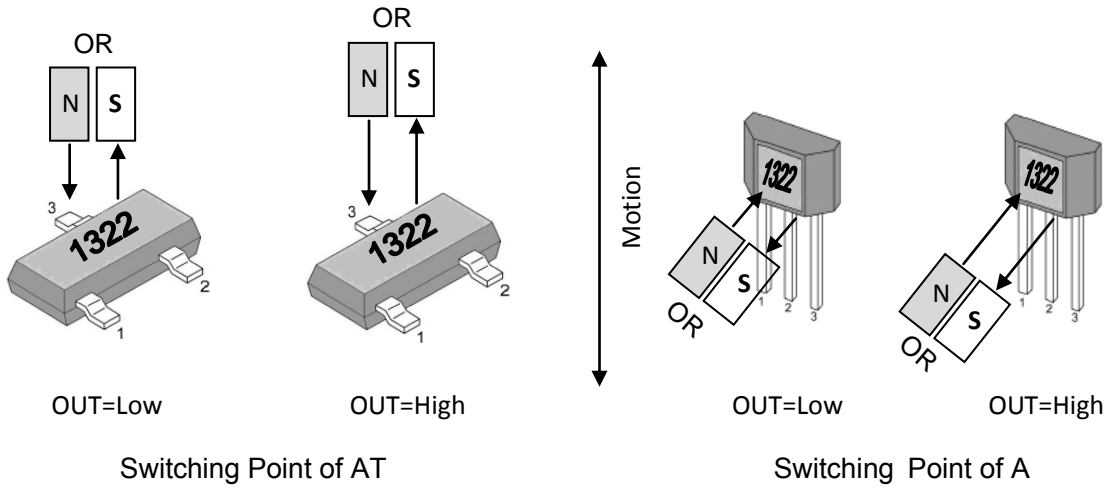

Note: Direction of magnetic flux

Pin Description

MT1322AT

Name	Number	Description
Vs	1	Power
GND	3	Ground
OUT	2	Include pull-up resistor

MT1322A (MT1322A-S MT1322A-T MT1322A-TS)

Name	Number	Description
Vs	1	Power
GND	2	Ground
OUT	3	Include pull-up resistor

Electrical and Magnetic Characteristics

Absolute Maximum Ratings

Absolute maximum ratings are limiting values to be applied individually, and beyond which the serviceability of the circuit may be impaired. Functional operability is not necessarily implied. Exposure to absolute maximum rating conditions for an extended period of time may affect device reliability.

Absolute maximum ratings: all voltages listed are referenced to GND.

Symbol	Parameters	Min	Max	Units
V _S	Supply Voltage	-	5.5	V
V _{RCC}	Reverse Battery Voltage	-	-0.5	V
V _{OUT}	Output Voltage	-	5.5	V
I _{OUT}	Continuous output current	-	10	mA
T _A	Operating Ambient Temperature	-40	85	°C
T _S	Storage temperature	-50	150	°C
T _J	Junction temperature	-	150	°C
B	Magnetic flux	No Limit		Gauss

MT1322 Series Specifications

At T_A = -40°C to 85°C, V_S = 2.2V to 5.5V (unless otherwise specified)

Symbol	Parameter	Test Condition	Min	Typ	Max	Units
V _S	Supply Voltage	Operating	2.2	-	5.5	V
I _{S(AVG)}	Supply Current	B < B _{RP} , V _S = 3.6V	-	4	6	µA
I _{S(EN)}		Chip awake, B < B _{RP} , V _S = 3.6V	-	2	3	mA
I _{S(DIS)}		Chip asleep, B < B _{RP} , V _S = 3.6V	-	2	3	µA
V _{SON}	Output Saturation Voltage	B > B _{OP}	-	-	0.4	V
I _{OFF}	Output Leakage Current	B < B _{RP} , V _{OUT} = 5V	-	-	0.1	µA
T _{AW}	Awake Time	V _S = 3.6V	30	50	70	µs
T _{SL}	Sleep Time	V _S = 3.6V	30	35	40	ms
D.C.	Duty Cycle		-	0.17	-	%
B _{OP}	Magnetic Operating Point	At T _A = 25°C	+/-13	+/-18	+/-23	Gauss
B _{RP}	Magnetic Release Point	At T _A = 25°C	+/-5	+/-10	+/-15	Gauss
B _{HYST}	Hysteresis Window	At T _A = 25°C, B _{OP} - B _{RP}	-	8	-	Gauss

Typical Application Circuit

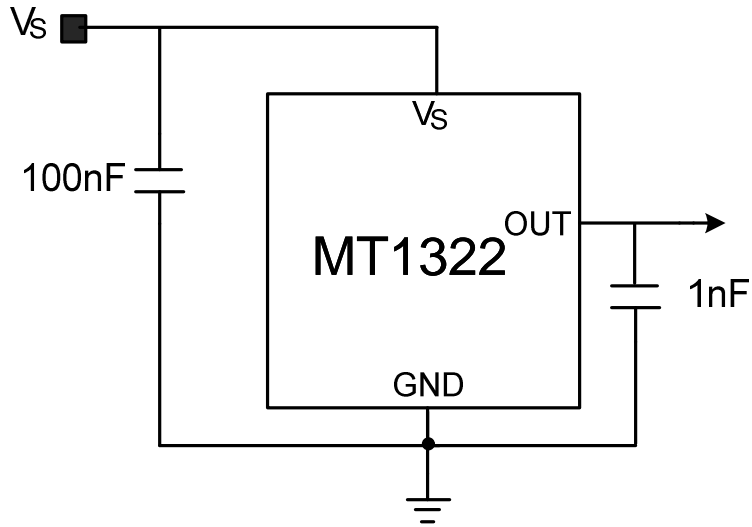

Typical Output Waveform (The TO-92 package as an example)

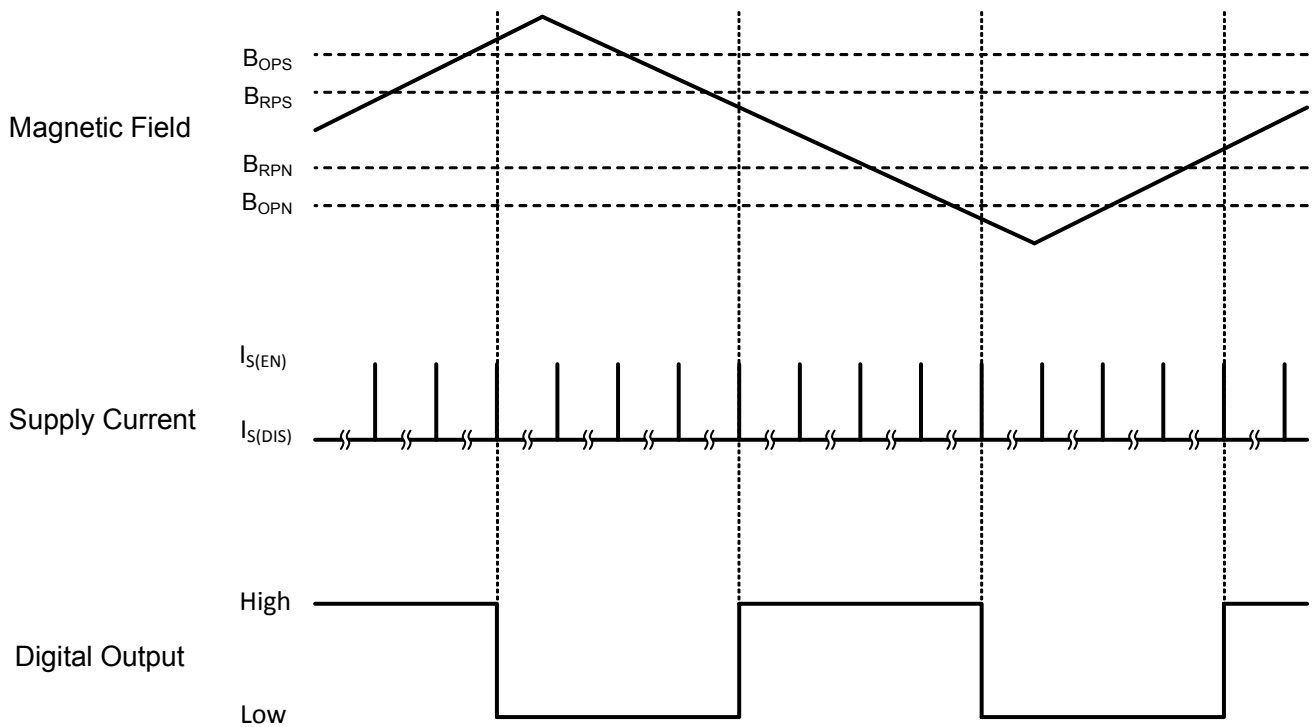

PACKAGE DESIGNATOR (MT1322A MT1322A-S) Flat TO-92

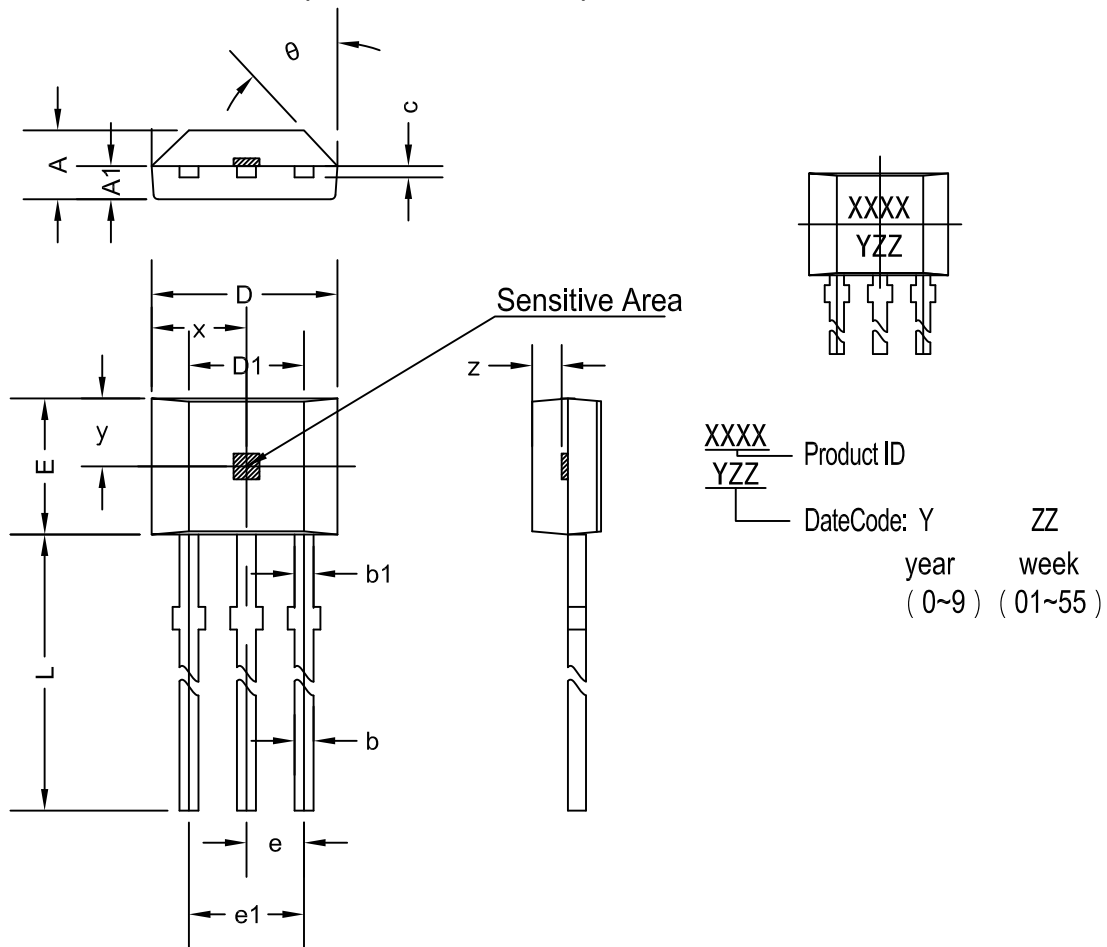

Symbol	Dimensions in Millimeters		Dimensions in Inches	
	Min	Max	Min	Max
A	1.420	1.670	0.056	0.066
A1	0.660	0.860	0.026	0.034
b	0.350	0.560	0.014	0.022
b1	0.400	0.550	0.016	0.022
c	0.360	0.510	0.014	0.020
D	3.900	4.200	0.154	0.165
D1	2.970	3.270	0.117	0.129
E	2.900	3.280	0.114	0.129
e	1.270 TYP.		0.050 TYP.	
e1	2.440	2.640	0.096	0.104
L(A)	13.500	15.500	0.531	0.610
L(A-S)	3.000	4.000	0.118	0.157
x	2.025 TYP.		0.080 TYP.	
y	1.545 TYP.		0.061 TYP.	
z	0.500 TYP.		0.020 TYP.	
θ	45° TYP.		45° TYP.	

PACKAGE DESIGNATOR

(MT1322A-T MT1322A-TS) Flat TO-92 Radial Lead

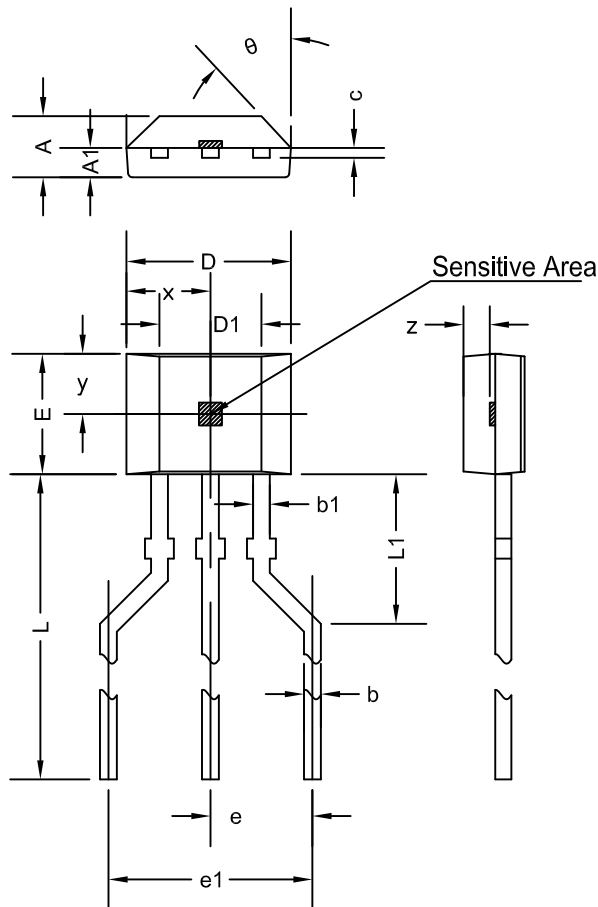

XXXX Product ID
 YZZ DateCode: Y ZZ
 year week
 (0~9) (01~55)

Symbol	Dimensions in Millimeters		Dimensions in Inches	
	Min	Max	Min	Max
A	1.420	1.670	0.056	0.066
A1	0.660	0.860	0.026	0.034
b	0.350	0.560	0.014	0.022
b1	0.400	0.550	0.016	0.022
C	0.360	0.510	0.014	0.020
D	3.900	4.200	0.154	0.165
D1	2.970	3.270	0.117	0.129
E	2.900	3.280	0.114	0.129
e	2.540 TYP.		0.100 TYP.	
e1	5.080 TYP.		0.200 TYP.	
L(A-T)	14.300 REF.		0.563 REF.	
L(A-TS)	5.200	5.700	0.205	0.224
L1	2.150 REF.		0.085 REF.	
x	2.025 TYP.		0.080 TYP.	
y	1.545 TYP.		0.061 TYP.	
z	0.500 TYP.		0.020 TYP.	
θ	45° TYP.		45° TYP.	

PACKAGE DESIGNATOR (MT1322AT) SOT-23

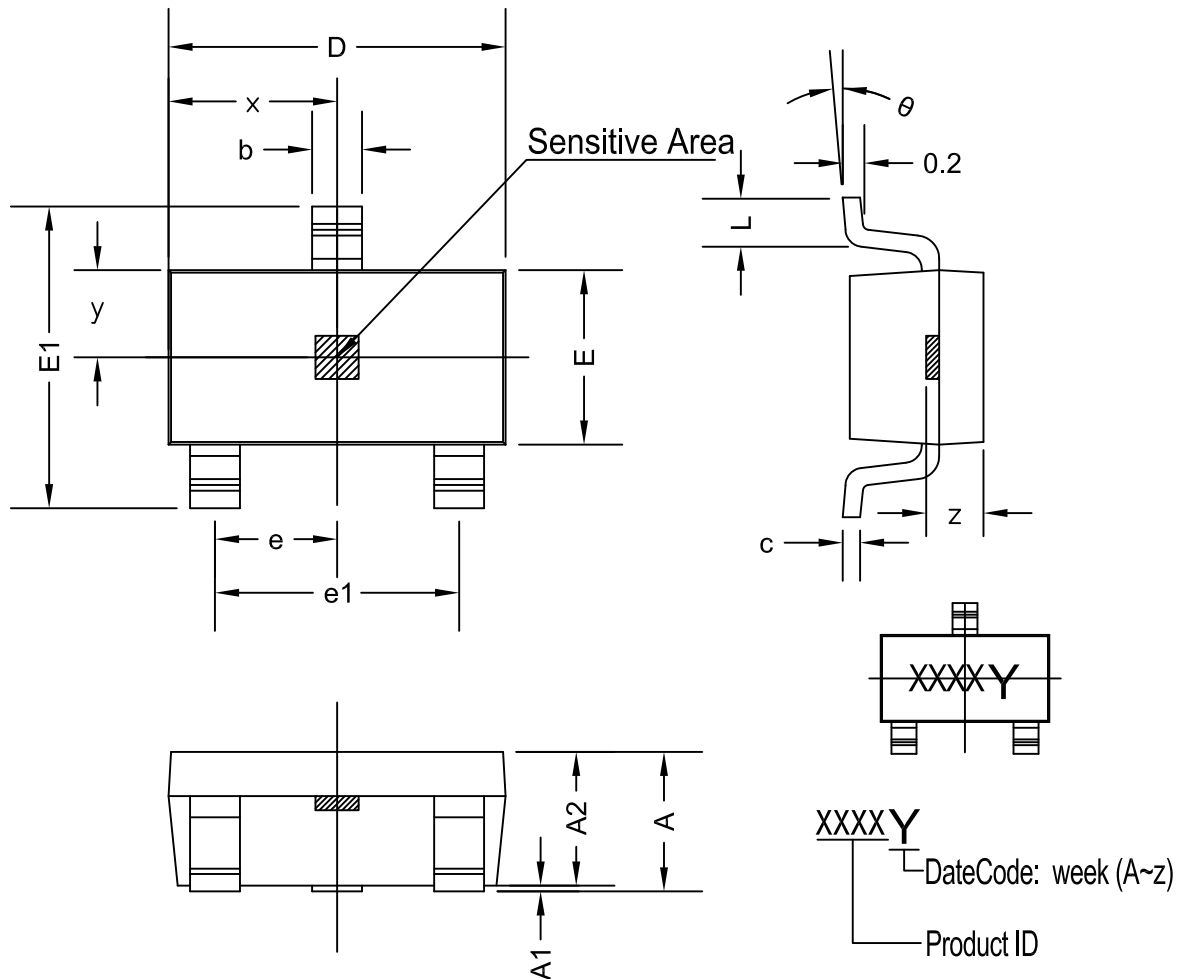

Symbol	Dimensions in Millimeters		Dimensions in Inches	
	Min	Max	Min	Max
A	1.050	1.250	0.041	0.049
A1	0.000	0.100	0.000	0.004
A2	1.050	1.150	0.041	0.045
b	0.300	0.500	0.012	0.020
c	0.100	0.200	0.004	0.008
D	2.820	3.020	0.111	0.119
E	1.500	1.700	0.059	0.067
E1	2.650	2.950	0.104	0.116
e	0.950 TYP.		0.037 TYP.	
e1	1.800	2.000	0.071	0.079
L	0.300	0.600	0.012	0.024
x	1.460 TYP.		0.057 TYP.	
y	0.800 TYP.		0.032 TYP.	
z	0.600 TYP.		0.024 TYP.	
θ	0°	8°	0°	8°

单击下面可查看定价，库存，交付和生命周期等信息

[>>Magntek\(麦歌恩\)](#)