

Features and Benefits

- **CMOS Technology**
- **Magnetic Type: Latch**
- **Wide Operating Voltage Range:**
Supply Voltage 3.0~18V
- **Specified Operating Temperature Range:**
From -40°C~125°C
- **High Magnetic Sensitivity**
 $B_{OP}=20\text{Gauss}$, $B_{RP}=-20\text{Gauss}$ (typical)
- **Lower Power Consumption**
Supply Current <3mA
- **Lead Free Package**
Flat TO-92, SOT-23, SOT-89B
- **High ESD Rating**
- **Open Drain Output**
- **Reversed Power Supply Protection**
- **RoHS Compliant**
2011/65/EU

Applications

- Home appliances, Industrial
- Electric Fan, Electric tools
- Brushless DC Motor Communication
- Magnetic Encoder
- Solid-State Switch
- Water Flow Sensor

Family Members

Part number	Description
MT1401A	Flat TO-92 package, bulk packaging (1000pcs/bag)
MT1401A-T	Flat TO-92 package, radial lead, bulk packaging (1000pcs/bag)
MT1401AT	SOT-23 package, tape and reel packaging (3000pcs/bag)
MT1401BT	SOT-89B package, tape and reel packaging (1000pcs/bag)
MT1401ET	SOT-23(thin outline) package, tape and reel packaging (3000pcs/bag)

General Description

The MT1401 family, produced with CMOS technology. The Hall IC internally includes an on-chip Hall voltage generator, a voltage regulator for operation with supply voltages of 3.0 to 18V, temperature compensation circuitry, small-signal amplifier, Hall sensor with dynamic offset cancellation system, Schmitt trigger and an open-drain output.

They are designed to respond to alternating North and South poles. While the magnetic flux density(B) is larger than operate point (B_{OP}), the output will be turned on (Low), the output is held until the magnetic flux density(B) is lower than release point (B_{RP}), then turn off (High).

The MT1401 family provides a variety of packages to customers: SOT-23/SOT-89B for surface mount and flat TO-92 for through-hole mount. All packages are RoHS compliant.

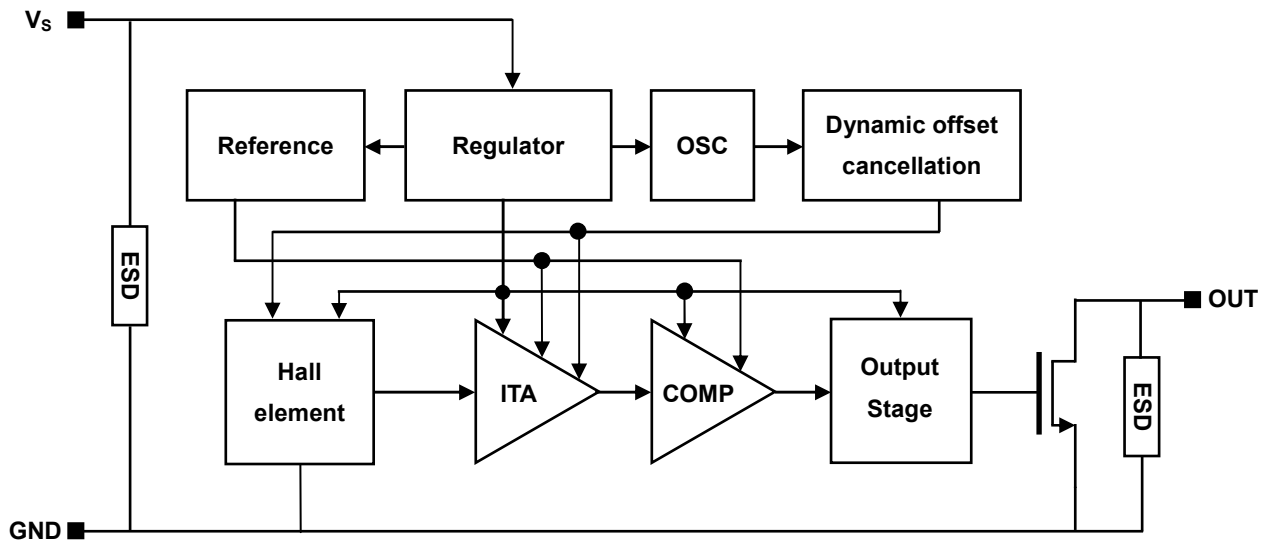

Functional Block Diagram

Function Description

Definition of Magnetic Parameters

B_{OP} : Operating Point, Magnetic flux density applied on the branded side of the package which turns the output driver ON ($V_{OUT}=Low$)

B_{RP} : Release Point, Magnetic flux density applied on the branded side of the package which turns the output driver OFF ($V_{OUT}=High$)

B_{HYST} : Hysteresis Window, $|B_{OP}-B_{RP}|$

Definition of Switching Function

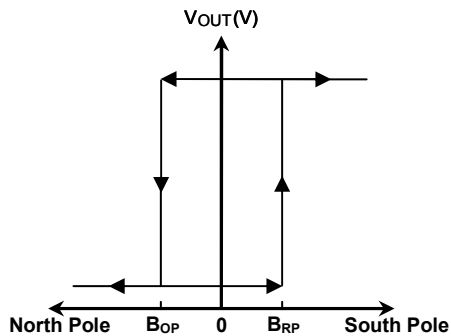

Switching Behavior of AT

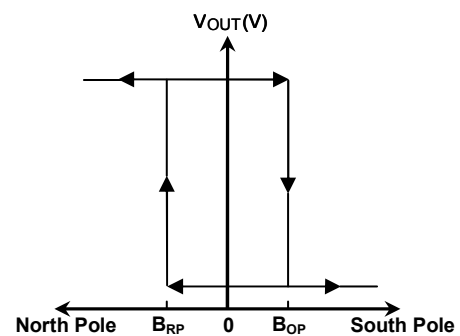

Switching Behavior of A, BT and ET

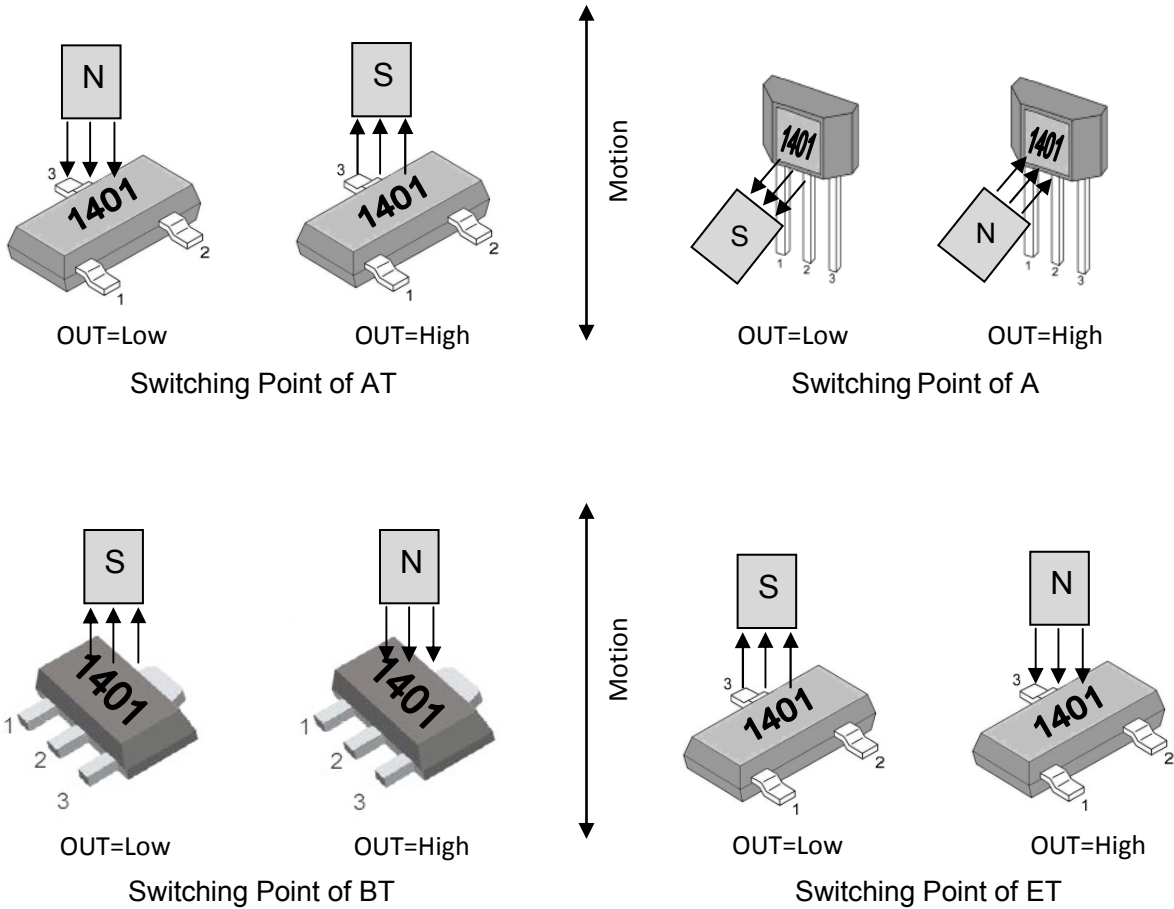

Note: Direction of magnetic flux

Pin Description

MT1401AT

Name	Number	Description
Vs	1	Power
GND	3	Ground
OUT	2	Open-Drain output

MT1401A (MT1401A-T)

Name	Number	Description
Vs	1	Power
GND	2	Ground
OUT	3	Open-Drain output

MT1401BT

Name	Number	Description
Vs	1	Power
GND	2	Ground
OUT	3	Open-Drain output

MT1401ET

Name	Number	Description
Vs	1	Power
GND	3	Ground
OUT	2	Open-Drain output

Electrical and Magnetic Characteristics

Absolute Maximum Ratings

Absolute maximum ratings are limiting values to be applied individually, and beyond which the serviceability of the circuit may be impaired. Functional operability is not necessarily implied. Exposure to absolute maximum rating conditions for an extended period of time may affect device reliability.

Absolute maximum ratings: all voltages listed are referenced to GND.

Symbol	Parameters	Min	Max	Units
V _S	Supply Voltage	-	30	V
V _{RCC}	Reverse Battery Voltage	-	-30	V
V _{OUT}	Output Voltage	-	30	V
I _{OUT}	Continuous output current	-	50	mA
T _A	Operating Ambient Temperature	-40	125	°C
T _S	Storage temperature	-50	150	°C
T _J	Junction temperature	-	165	°C
B	Magnetic flux	No Limit		Gauss

MT1401 Series Specifications

At T_A = -40°C to 125°C, V_S = 3.0V to 18V (unless otherwise specified)

Symbol	Parameter	Test Condition	Min	Typ	Max	Units
V _S	Supply Voltage	Operating	3.0	-	18	V
I _S	Supply Current	B < B _{RP}	0.5	-	2	mA
V _{DSON}	Output Saturation Voltage	I _{OUT} = 10mA, B > B _{OP}	-	-	0.4	V
I _{OFF}	Output Leakage Current	B < B _{RP} , V _{OUT} = 18V	-	-	10	µA
T _R	Output Rise Time	R _L = 1KOhm, C _L = 20pF	-	-	4.0	µs
T _F	Output Fall Time	R _L = 1KOhm, C _L = 20pF	-	-	1.0	µs
T _{PO}	Power-On Time	V _S > 3.0 V, B < B _{RP} (min) - 10 G, B > B _{OP} (max) + 10 G	-	-	100	µs
F _{SW}	Maximum Switching Frequency		10	-	-	KHz
R _{TH}	SOT-23 Package Thermal Resistance		-	301	-	°C/W
	TO-92 Package Thermal Resistance		-	230	-	°C/W
	SOT-89B Package Thermal Resistance		-	230	-	°C/W
B _{OP}	Magnetic Operating Point	At T _A = 25°C	5	20	40	Gauss
B _{RP}	Magnetic Release Point	At T _A = 25°C	-40	-20	-5	Gauss
B _{HYST}	Hysteresis Window	At T _A = 25°C, B _{OP} - B _{RP}	10	40	80	Gauss

Typical Application Circuit Note: R_L recommend 1KOhm to 10KOhm

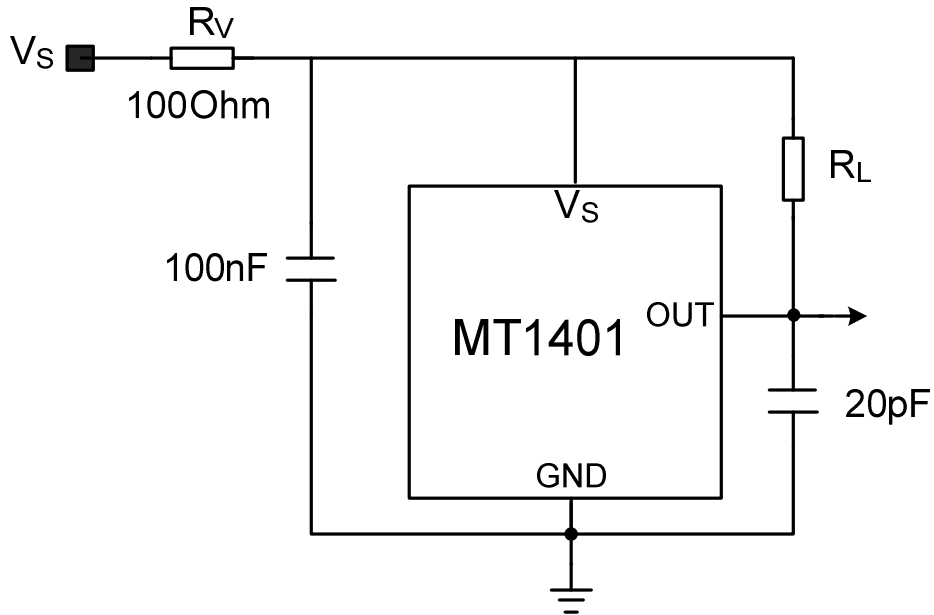

Typical Output Waveform (The TO-92 package as an example)

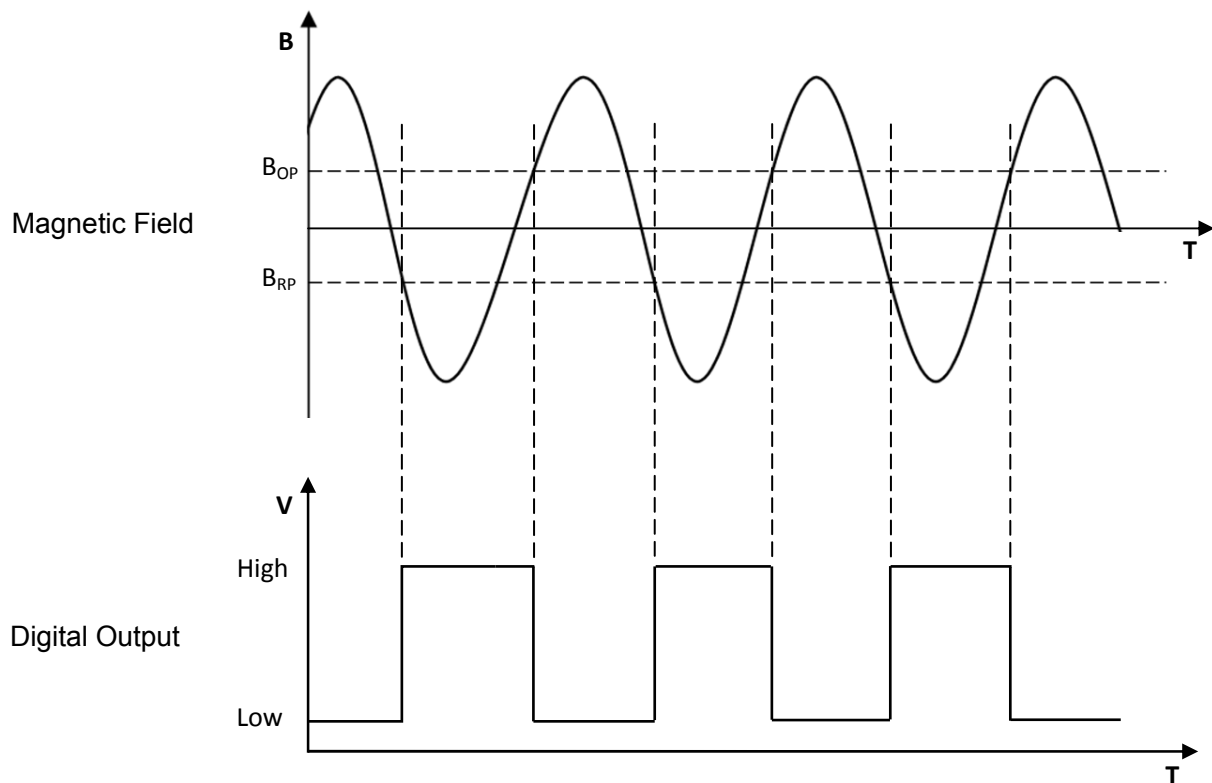

PACKAGE DESIGNATOR (MT1401AT) SOT-23

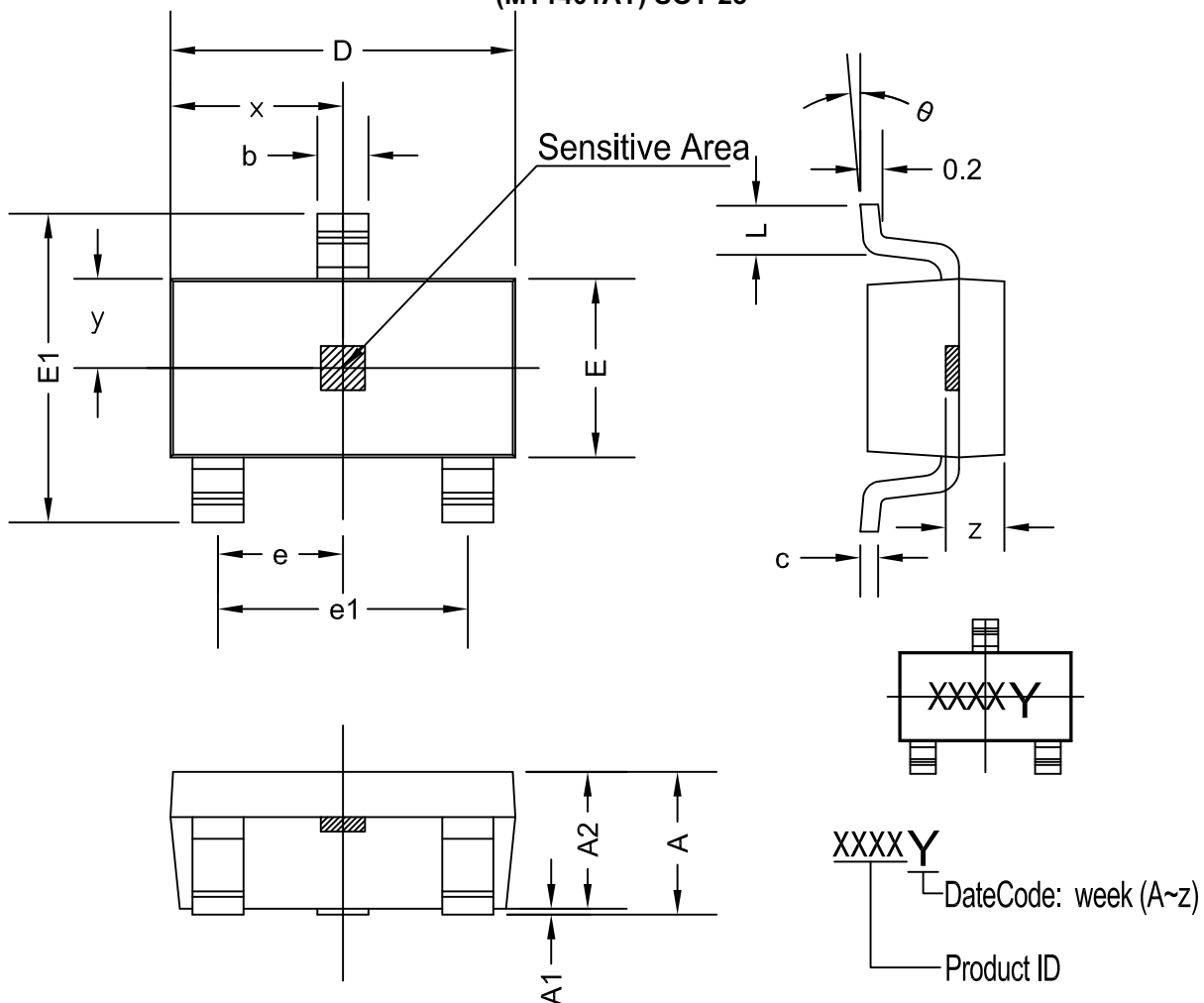

Symbol	Dimensions in Millimeters		Dimensions in Inches	
	Min	Max	Min	Max
A	1.050	1.250	0.041	0.049
A1	0.000	0.100	0.000	0.004
A2	1.050	1.150	0.041	0.045
b	0.300	0.500	0.012	0.020
c	0.100	0.200	0.004	0.008
D	2.820	3.020	0.111	0.119
E	1.500	1.700	0.059	0.067
E1	2.650	2.950	0.104	0.116
e	0.950 TYP		0.037 TYP	
e1	1.800	2.000	0.071	0.079
L	0.300	0.600	0.012	0.024
x	1.460 TYP		0.057 TYP	
y	0.800 TYP		0.032 TYP	
z	0.600 TYP		0.024 TYP	
θ	0°	8°	0°	8°

PACKAGE DESIGNATOR (MT1401BT) SOT-89B

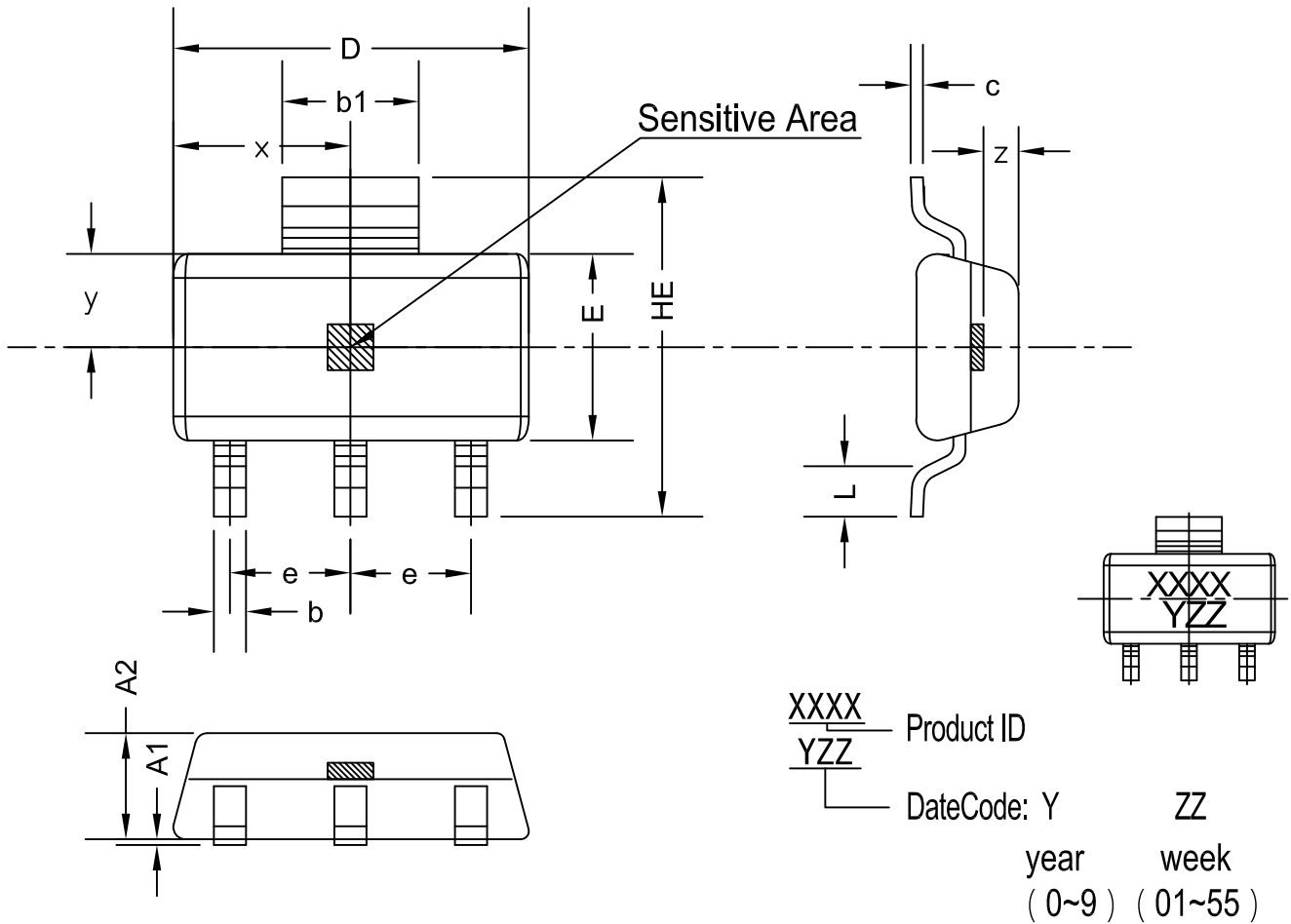

Symbol	Dimensions in Millimeters		Dimensions in Inches	
	Min	Max	Min	Max
A1	0.000	0.100	0.000	0.004
A2	1.220	1.420	0.048	0.056
b	0.300	0.500	0.012	0.020
b1	1.600	1.800	0.063	0.070
D	4.400	4.600	0.173	0.181
c	1.152 REF		0.045 REF	
E	2.400	2.600	0.094	0.102
HE	4.000	4.400	0.157	0.173
e	1.500 TYP		0.060 TYP	
L	0.350	0.550	0.014	0.022
x	2.250TYP		0.089TYP	
y	1.250TYP		0.049TYP	
z	0.300TYP		0.012TYP	

PACKAGE DESIGNATOR (MT1401ET) SOT-23 (thin outline)

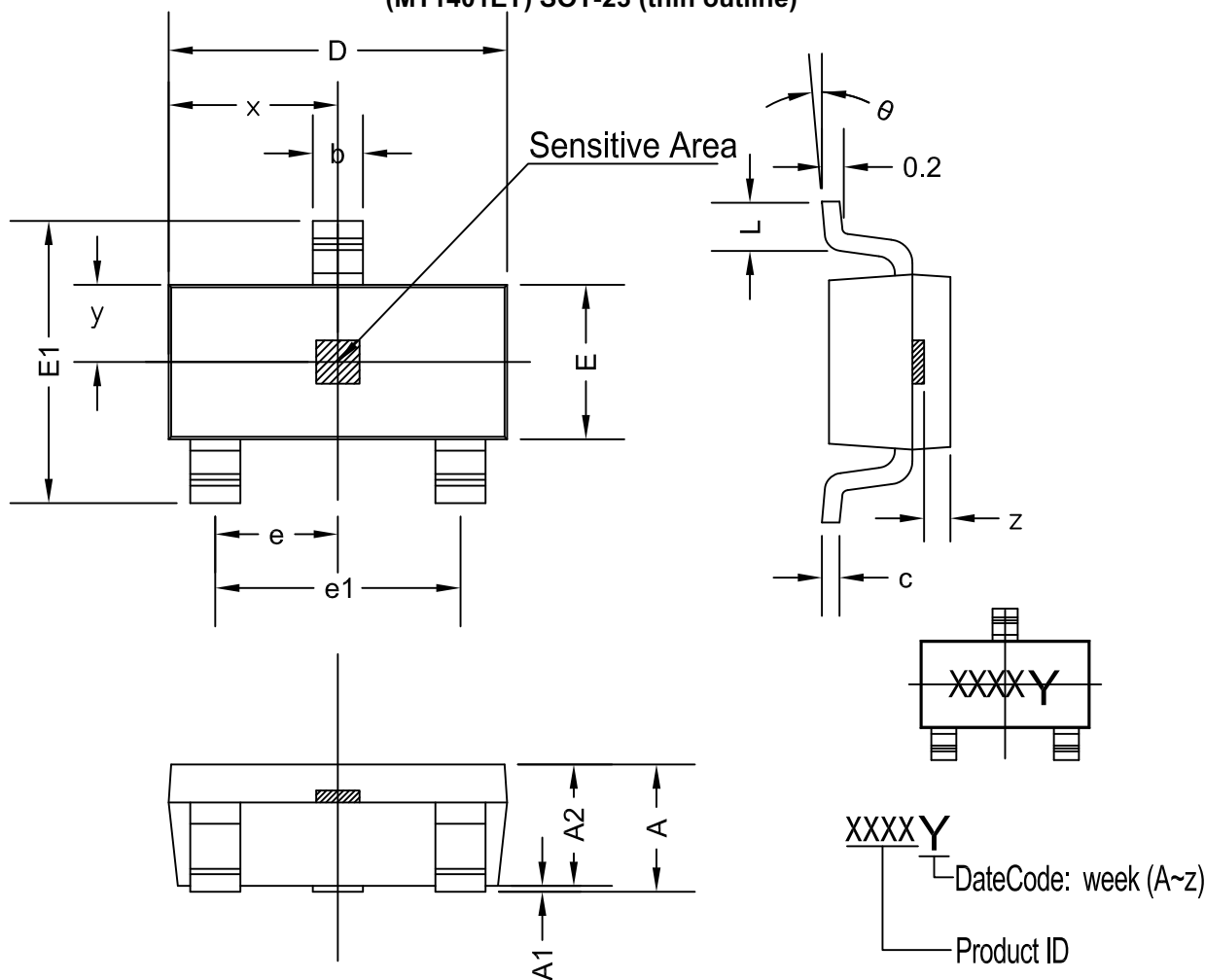

Symbol	Dimensions in Millimeters		Dimensions in Inches	
	Min	Max	Min	Max
A	0.900	1.150	0.035	0.045
A1	0.000	0.100	0.000	0.004
A2	0.900	1.050	0.035	0.041
b	0.300	0.500	0.012	0.020
c	0.080	0.150	0.003	0.006
D	2.800	3.000	0.110	0.118
E	1.200	1.400	0.047	0.055
E1	2.250	2.550	0.089	0.100
e	0.950 TYP		0.037 TYP	
e1	1.800	2.000	0.071	0.079
L	0.550 REF		0.022 REF	
x	1.460 TYP		0.057 TYP	
y	0.650 TYP		0.026 TYP	
z	0.500 TYP		0.020 TYP	
θ	0°	8°	0°	8°

单击下面可查看定价，库存，交付和生命周期等信息

[>>Magntek\(麦歌恩\)](#)