

	<b>E480232</b>
---	----------------

### Features

- For Bidirectional Devices Add "C" To The Suffix of The Part Number: i.e.SMBJ1.0KE6.8CA for 5% Tolerance
- Low Leakage
- Excellent Clamping Capability
- Very Fast Response Time
- Excellent Clamping Capability
- Halogen Free. "Green" Device (Note 1)
- Moisture Sensitivity Level 1
- Epoxy Meets UL 94 V-0 Flammability Rating
- Lead Free Finish/RoHS Compliant (Note 2) ("P" Suffix Designates RoHS Compliant. See Ordering Information)

### Mechanical Data

- Polarity: Color Band Denotes Positive End( Cathode) Except Bi-directional Types
- Terminals: Solderable Per MIL-STD-750, Method 2026

### Maximum Ratings

- Operating Junction Temperature Range: -55°C to +150°C
- Storage Temperature Range: -55°C to +150°C

### Electrical Characteristics @ 25°C Unless Otherwise Specified

Peak Pulse Power Surge Current on 10/1000µs Waveform	$I_{PP}$	See the Table	Note 3
Peak Pulse Power Dissipation	$P_{PP}$	1000W	Note 3
Power Dissipation on infinite heat sink	$P_D$	5.0W	$T_L = 75^\circ\text{C}$
Peak forward surge current, 8.3 ms single half sine-wave unidirectional only	$I_{FSM}$	100A	Note 4
Maximum instantaneous forward voltage at 50A for unidirectional only	$V_F$	3.5V/5V	Note 5

#### Notes:

1. Halogen free "Green" products are defined as those which contain <900ppm bromine, <900ppm chlorine (<1500ppm total Br + Cl) and <1000ppm antimony compounds.
2. High Temperature Solder Exemption Applied, see EU Directive Annex 7a.
3. Non-repetitive current pulse, per Fig.3 and derated above  $T_A=25^\circ\text{C}$  per Fig.4.
4. Measured on 8.3 ms single half sine-wave or equivalent square wave, duty cycle= 4 pulses per minute maximum.
5.  $V_F < 3.5\text{V}$  for devices of  $V_{BR} < 50\text{V}$ .

#### Pin Configuration:

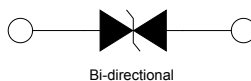
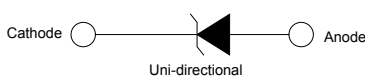

## 1000 Watt TVS 6.8 to 91 Volts

### SMB (DO-214AA) (LEAD FRAME)

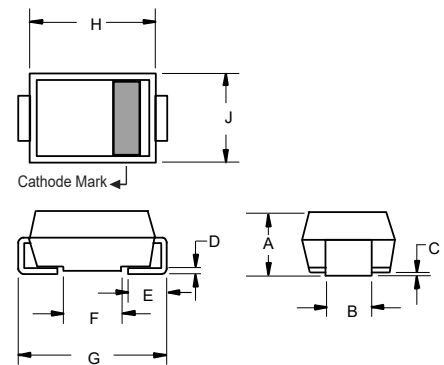

DIM	INCHES		MM		NOTE
	MIN	MAX	MIN	MAX	
A	0.079	0.103	2.00	2.62	
B	0.075	0.087	1.91	2.21	
C	0.002	0.008	0.05	0.20	
D	0.006	0.012	0.15	0.31	
E	0.030	0.060	0.76	1.52	
F	0.065	0.091	1.65	2.32	
G	0.200	0.220	5.08	5.59	
H	0.160	0.191	4.06	4.85	
J	0.130	0.155	3.30	3.94	

#### Suggested Solder Pad Layout

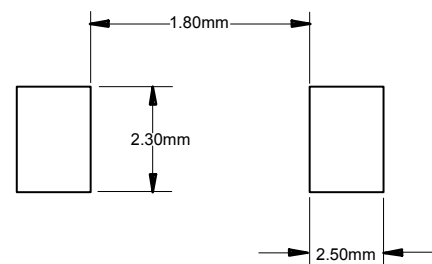

Electrical Characteristics @ 25°C Unless Otherwise Specified

MCC PART NUMBER		Breakdown Voltage $V_{BR}$ @ $I_T$			Maximum Reverse Leakage $I_R$ @ $V_{RWM}$ ( $\mu$ A)	Working Peak Reverse Voltage $V_{RWM}$ (V)	Maximum Reverse Surge Current $I_{PP}$ (A)	Maximum Clamping Voltage $V_C$ @ $I_{PP}$ (V)	Device Marking Code	
									Min(V)	Max(V)
SMBJ1.0KE6.8A	SMBJ1.0KE6.8CA	6.46	7.14	10	900	5.8	95.2	10.5	A10A	N10A
SMBJ1.0KE7.5A	SMBJ1.0KE7.5CA	7.13	7.88	10	400	6.4	88.5	11.3	A10B	N10B
SMBJ1.0KE8.2A	SMBJ1.0KE8.2CA	7.79	8.61	10	180	7.0	82.6	12.1	A10C	N10C
SMBJ1.0KE9.1A	SMBJ1.0KE9.1CA	8.65	9.56	1	45	7.8	74.6	13.4	A10D	N10D
SMBJ1.0KE10A	SMBJ1.0KE10CA	9.50	10.50	1	8	8.6	69.0	14.5	A10E	N10E
SMBJ1.0KE11A	SMBJ1.0KE11CA	10.45	11.55	1	4	9.4	64.1	15.6	A10F	N10F
SMBJ1.0KE12A	SMBJ1.0KE12CA	11.40	12.60	1	1	10.2	59.9	16.7	A10G	N10G
SMBJ1.0KE13A	SMBJ1.0KE13CA	12.35	13.65	1	1	11.1	54.9	18.2	A10H	N10H
SMBJ1.0KE15A	SMBJ1.0KE15CA	14.25	15.75	1	1	12.8	47.2	21.2	A10I	N10I
SMBJ1.0KE16A	SMBJ1.0KE16CA	15.20	16.80	1	1	13.6	44.4	22.5	A10J	N10J
SMBJ1.0KE18A	SMBJ1.0KE18CA	17.10	18.90	1	1	15.3	39.7	25.2	A10K	N10K
SMBJ1.0KE20A	SMBJ1.0KE20CA	19.00	21.00	1	1	17.1	36.1	27.7	A10L	N10L
SMBJ1.0KE22A	SMBJ1.0KE22CA	20.90	23.10	1	1	18.8	32.7	30.6	A10M	N10M
SMBJ1.0KE24A	SMBJ1.0KE24CA	22.80	25.20	1	1	20.5	30.1	33.2	A10N	N10N
SMBJ1.0KE27A	SMBJ1.0KE27CA	25.65	28.35	1	1	23.1	26.7	37.5	A10O	N10O
SMBJ1.0KE30A	SMBJ1.0KE30CA	28.50	31.50	1	1	25.6	24.2	41.4	A10P	N10P
SMBJ1.0KE33A	SMBJ1.0KE33CA	31.35	34.65	1	1	28.2	21.9	45.7	A10Q	N10Q
SMBJ1.0KE36A	SMBJ1.0KE36CA	34.20	37.80	1	1	30.8	20.0	49.9	A10R	N10R
SMBJ1.0KE39A	SMBJ1.0KE39CA	37.05	40.95	1	1	33.3	18.6	53.9	A10S	N10S
SMBJ1.0KE43A	SMBJ1.0KE43CA	40.85	45.15	1	1	36.8	16.9	59.3	A10T	N10T
SMBJ1.0KE47A	SMBJ1.0KE47CA	44.65	49.35	1	1	40.2	15.4	64.8	A10U	N10U
SMBJ1.0KE51A	SMBJ1.0KE51CA	48.45	53.55	1	1	43.6	14.3	70.1	A10V	N10V
SMBJ1.0KE56A	SMBJ1.0KE56CA	53.20	58.80	1	1	47.8	13.0	77.0	A10W	N10W
SMBJ1.0KE62A	SMBJ1.0KE62CA	58.90	65.10	1	1	53.0	11.8	85.0	A10X	N10X
SMBJ1.0KE68A	SMBJ1.0KE68CA	64.60	71.40	1	1	58.1	10.9	92.0	A10Y	N10Y
SMBJ1.0KE75A	SMBJ1.0KE75CA	71.25	78.75	1	1	64.1	9.7	103.0	A10Z	N10Z
SMBJ1.0KE82A	SMBJ1.0KE82CA	77.90	86.10	1	1	70.1	8.8	113.0	B10A	O10A
SMBJ1.0KE91A	SMBJ1.0KE91CA	86.45	95.55	1	1	77.8	8.0	125.0	B10B	O10B

1. Add suffix 'CA' after part number to specify Bi-directional devices
2. For Bi-Directional devices having  $V_R$  of 10 volts and under, the  $I_R$  limit is double

Curve Characteristics

Fig. 1 - Peak Pulse Power Rating Curve

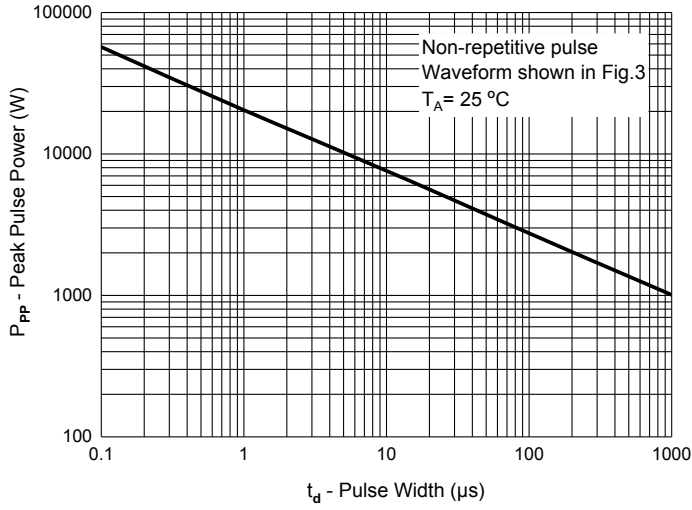

Fig. 2 - Typical Junction Capacitance

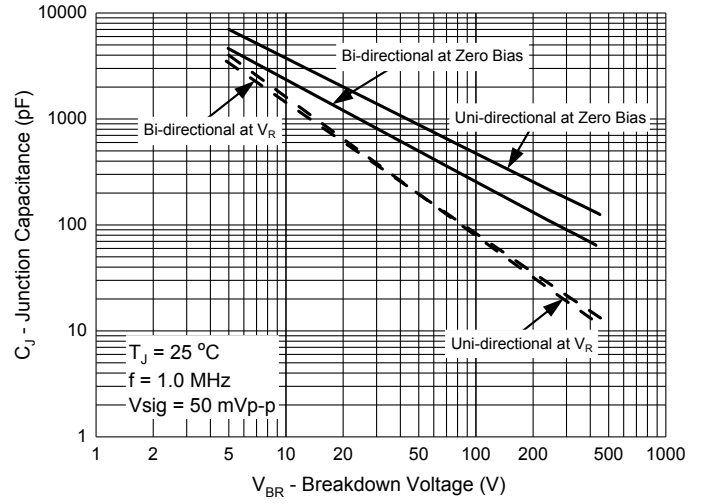

Fig. 3 - Pulse Waveform

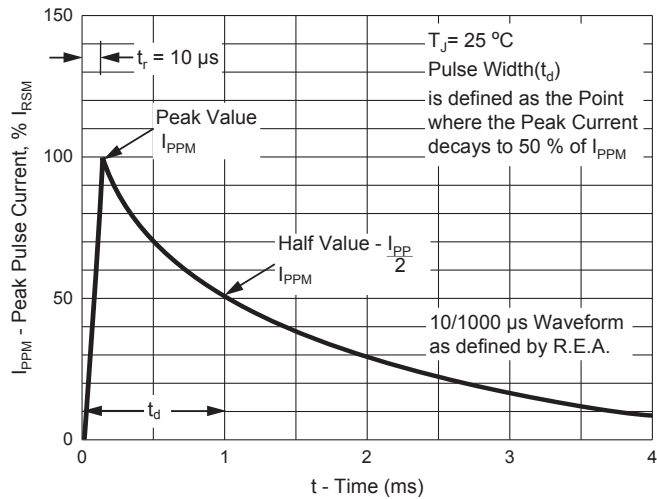
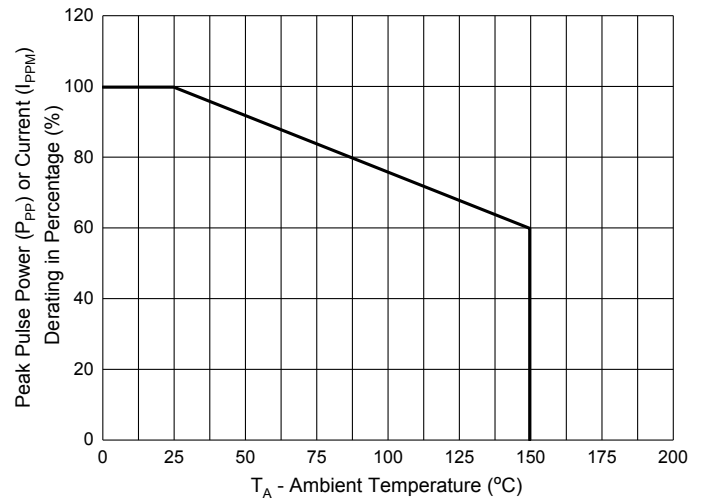

Fig. 4 - Pulse Derating Curve



## Ordering Information

Device	Packing
Part Number-TP	Tape&Reel:3Kpcs/Reel

### \*\*\*IMPORTANT NOTICE\*\*\*

**Micro Commercial Components Corp.** reserves the right to make changes without further notice to any product herein to make corrections, modifications, enhancements, improvements, or other changes. **Micro Commercial Components Corp.** does not assume any liability arising out of the application or use of any product described herein; neither does it convey any license under its patent rights, nor the rights of others. The user of products in such applications shall assume all risks of such use and will agree to hold **Micro Commercial Components Corp.** and all the companies whose products are represented on our website, harmless against all damages. **Micro Commercial Components Corp.** products are sold subject to the general terms and conditions of commercial sale, as published at <https://www.mccsemi.com/Home/TermsAndConditions>.

### \*\*\*LIFE SUPPORT\*\*\*

MCC's products are not authorized for use as critical components in life support devices or systems without the express written approval of Micro Commercial Components Corporation.

### \*\*\*CUSTOMER AWARENESS\*\*\*

Counterfeiting of semiconductor parts is a growing problem in the industry. Micro Commercial Components (MCC) is taking strong measures to protect ourselves and our customers from the proliferation of counterfeit parts. MCC strongly encourages customers to purchase MCC parts either directly from MCC or from Authorized MCC Distributors who are listed by country on our web page cited below. Products customers buy either from MCC directly or from Authorized MCC Distributors are genuine parts, have full traceability, meet MCC's quality standards for handling and storage. **MCC will not provide any warranty coverage or other assistance for parts bought from Unauthorized Sources.** MCC is committed to combat this global problem and encourage our customers to do their part in stopping this practice by buying direct or from authorized distributors.

单击下面可查看定价，库存，交付和生命周期等信息

[>>MCC\(美微科\)](#)