

Features

- Low $V_{CE(sat)}$ With SPT Technology
- $V_{CE(sat)}$ With Positive Temperature Coefficient
- Including Fast & Soft Recovery Anti-parallel FWD
- High Short Circuit Capability(10us)
- Low Inductance Module Structure
- Epoxy Meets UL 94 V-0 Flammability Rating
- Lead Free Finish/RoHS Compliant ("P" Suffix Designates RoHS Compliant. See Ordering Information)

Applications

- Inverter for Motor Drive
- AC and DC Servo Driver Amplifier
- UPS(Uninterruptible Power Supplies)
- Soft Switching Welding Machine

Maximum Ratings

- Maximum Junction Temperature : 175°C
- Operating Junction Temperature Range : -40°C to +150°C
- Storage Temperature Range: -40°C to +125°C
- IGBT Thermal Resistance: 0.18 K/W Junction to Case
- Diode Thermal Resistance: 0.31 K/W Junction to Case
- Type Conductive Grease Applied Thermal Resistance: 0.035K/W Junction to Case-To-Sink

Parameter	Symbol	Rating	Unit	
Collector-Emitter Voltage@ $V_{GE}=0V, I_C=1mA, T_{vj}=25^{\circ}C$	V_{CES}	1200	V	
Continuous Collector Current @ $T_C=100^{\circ}C$	I_C	150	A	
Peak Collector Current @ $T_p=1ms$	I_{CRM}	300	A	
Gate-Emitter Voltage@ $T_{vj}=25^{\circ}C$	V_{GE}	± 20	V	
Isolation Voltage @ $f=50Hz, t=1min$	V_{iso}	2500(Min)	V	
Weight of Module	G	315	g	
Module Electrodes Torque:M6	M_t	3~5	N*m	
Module-to-Sink Torque :M6	M_s	3~5	N*m	
Total Power Dissipation (IGBT-Inverter)	$T_C=25^{\circ}C$	P_{tot}	833	W
	$T_{vjmax}=175^{\circ}C$			

IGBT Modules
1200V 150A

C2

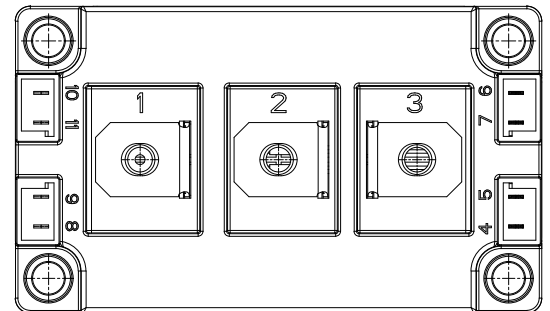
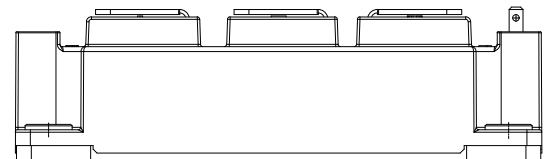

Circuit Diagram

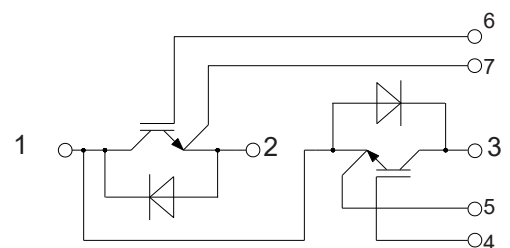

Electrical Characteristics of IGBT @ 25°C (Unless Otherwise Specified)

Parameter	Symbol	Test Conditions	Min	Typ	Max	Unit	
Gate-Emitter Threshold Voltage	$V_{GE(th)}$	$V_{CE}=V_{GE}, I_C=4mA, T_{vj}=25^{\circ}C$	5	6.2	7.0	V	
Collector-Emitter Cut-off Current	I_{CES}	$V_{CE}=1200V, V_{GE}=0V, T_{vj}=25^{\circ}C$			1.0	mA	
Collector-Emitter Saturation Voltage	$V_{CE(sat)}$	$V_{GE}=15V, I_C=150A, T_{vj}=25^{\circ}C$		1.85		V	
		$V_{GE}=15V, I_C=150A, T_{vj}=125^{\circ}C$		2.05			
Gate Charge	Q_G			1.56		uC	
Input Capacitance	C_{ies}	$V_{CE}=25V, V_{GE}=0V, f=1MHz,$ $T_{vj}=25^{\circ}C$		11		nF	
Reverse Transfer Capacitance	C_{res}			0.5			
Gate Emitter Leakage Current	I_{GES}	$V_{CE}=0V, V_{GE}=20V, T_{vj}=25^{\circ}C$			400	nA	
Turn-On Delay Time	$t_{d(on)}$	$V_{CE}=600V,$ $I_C=150A,$ $V_{GE}=\pm 15V,$ $R_G=4.7\Omega,$ $T_{vj}=25^{\circ}C$		347		ns	
Rise Time	t_r			75			
Turn-Off Delay Time	$t_{d(off)}$			375			
Fall Time	T_f			181			
Energy Dissipation During Turn-on Time	E_{on}			8.9			mJ
Energy Dissipation During Turn-off Time	E_{off}		9.3				
Turn-On Delay Time	$t_{d(on)}$	$V_{CE}=600V,$ $I_C=150A,$ $V_{GE}=\pm 15V,$ $R_G=4.7\Omega,$ $T_{vj}=125^{\circ}C$		352		ns	
Rise Time	t_r			81			
Turn-Off Delay Time	$t_{d(off)}$			301			
Fall Time	T_f			327			
Energy Dissipation During Turn-on Time	E_{on}			11.9			mJ
Energy Dissipation During Turn-off Time	E_{off}			16.0			
SC data	I_{sc}	$T_P \leq 10\mu s, V_{GE}=15V,$ $T_{vj}=150^{\circ}C, V_{CC}=900, V_{CEM} \leq 1200V$		890		A	

Electrical Characteristics of DIODE @ 25°C (Unless Otherwise Specified)

Parameter	Symbol	Test Conditions	Min	Typ	Max	Unit
Diode DC Forward Current	I_F	$T_C=100^\circ\text{C}$		150		A
Diode Peak Forward Current	I_{FRM}	$t_p=1\text{ms}$		300		A
Forward Voltage	V_F	$I_F=150\text{A}, T_{vj}=25^\circ\text{C}$		1.80	2.00	V
		$I_F=150\text{A}, T_{vj}=125^\circ\text{C}$		1.85		
Recovered Charge	Q_{rr}	$V_R=600\text{V}, I_F=150\text{A},$ $-di_F/dt=2250\text{A}/\mu\text{s},$ $T_{vj}=25^\circ\text{C}$		14.0		μC
Peak Reverse Recovery Current	I_{rr}			143		A
Reverse Recovery Energy	E_{rec}			9.5		mJ
Recovered Charge	Q_{rr}	$V_R=600\text{V}, I_F=150\text{A},$ $-di_F/dt=2250\text{A}/\mu\text{s},$ $T_{vj}=125^\circ\text{C}$		18.5		μC
Peak Reverse Recovery Current	I_{rr}			179		A
Reverse Recovery Energy	E_{rec}			17.5		mJ

Curve Characteristics

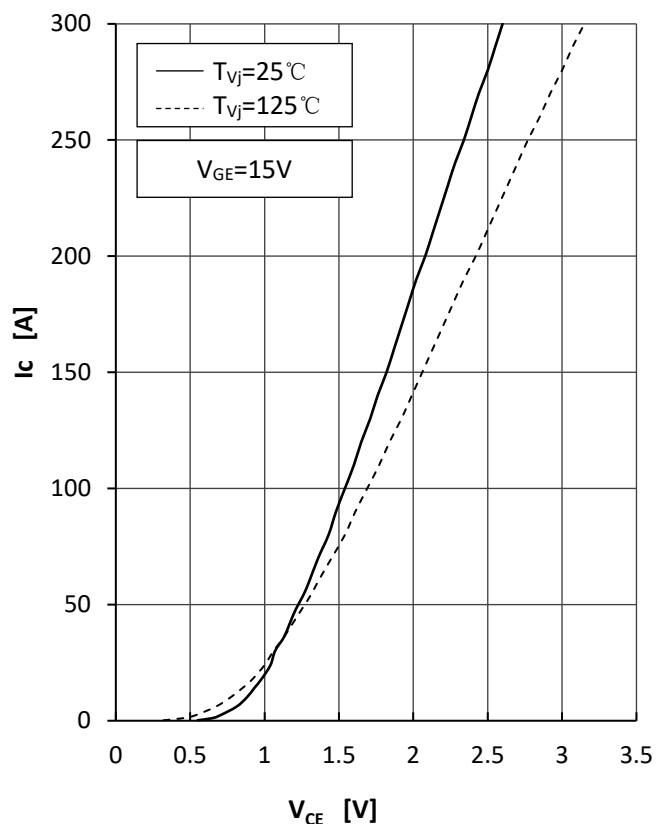

Fig1.IGBT Output Characteristics

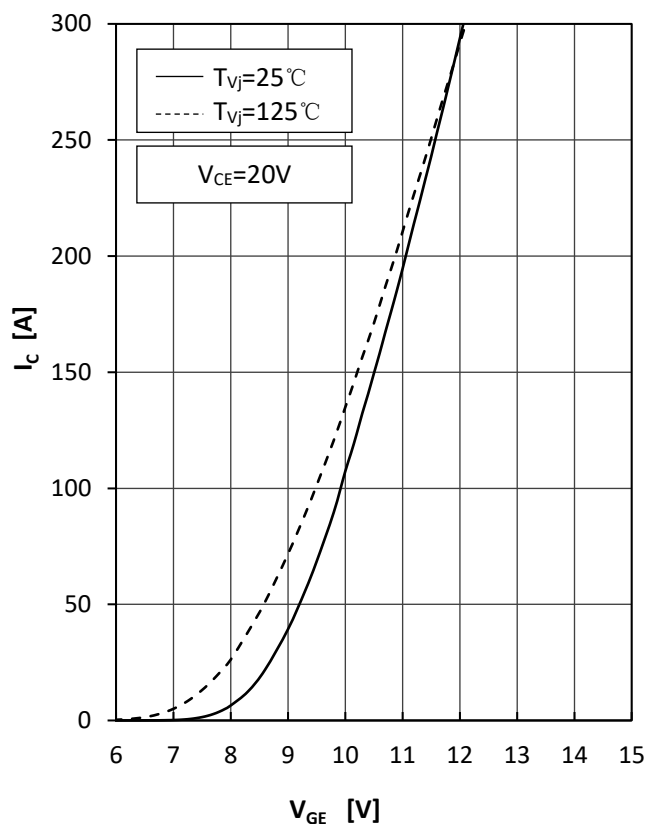

Fig2.IGBT Transfer Characteristics

Curve Characteristics

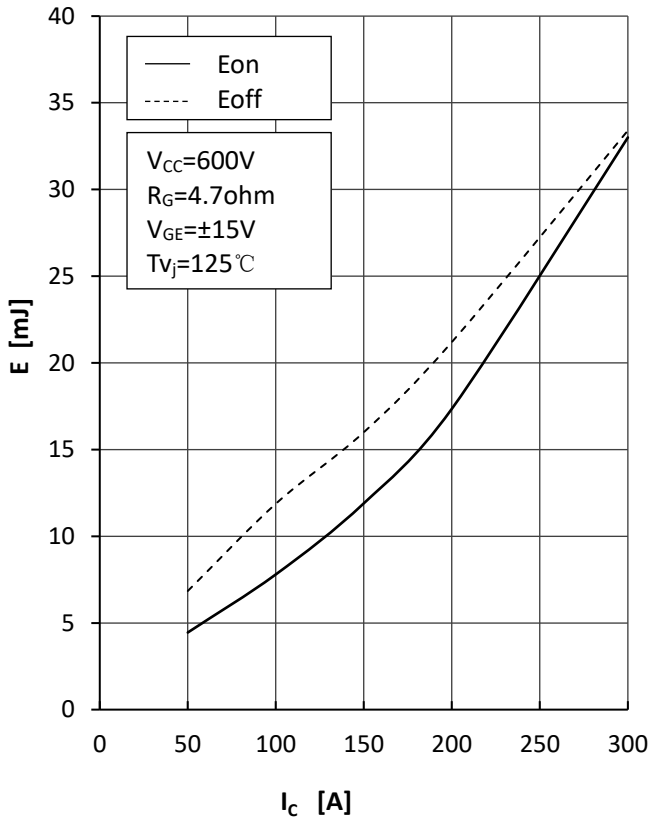

Fig3.IGBT Switching Loss vs.Ic

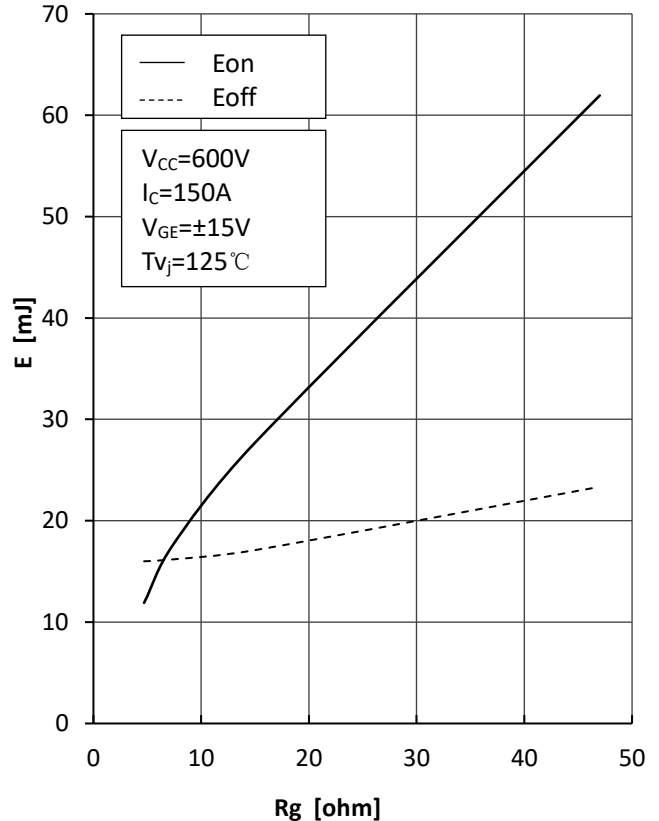

Fig4.IGBT Switching Loss vs.Rg

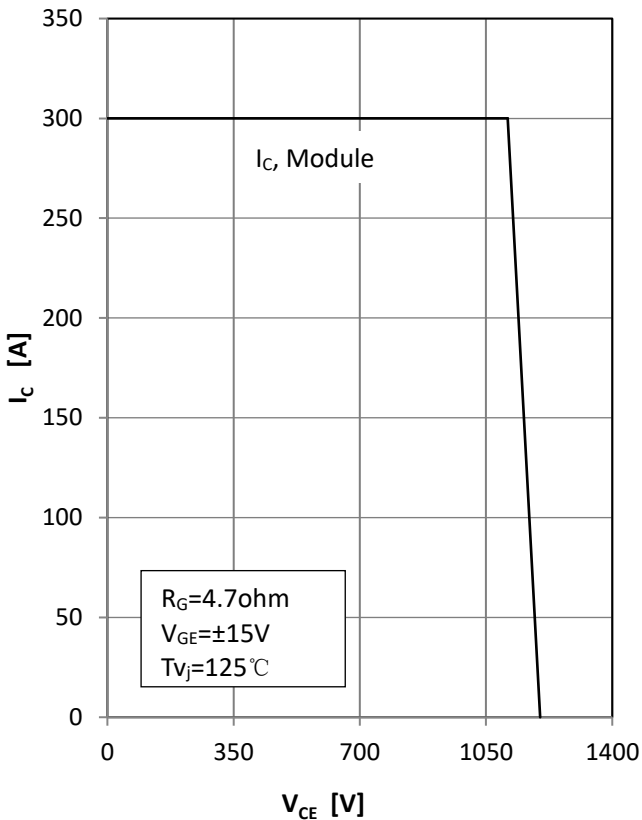

Fig5. RBSOA

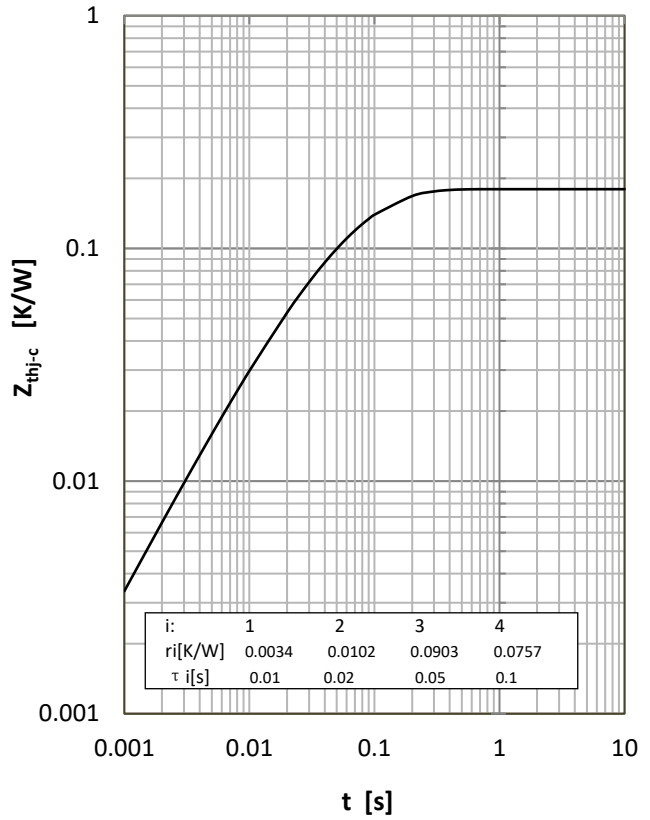
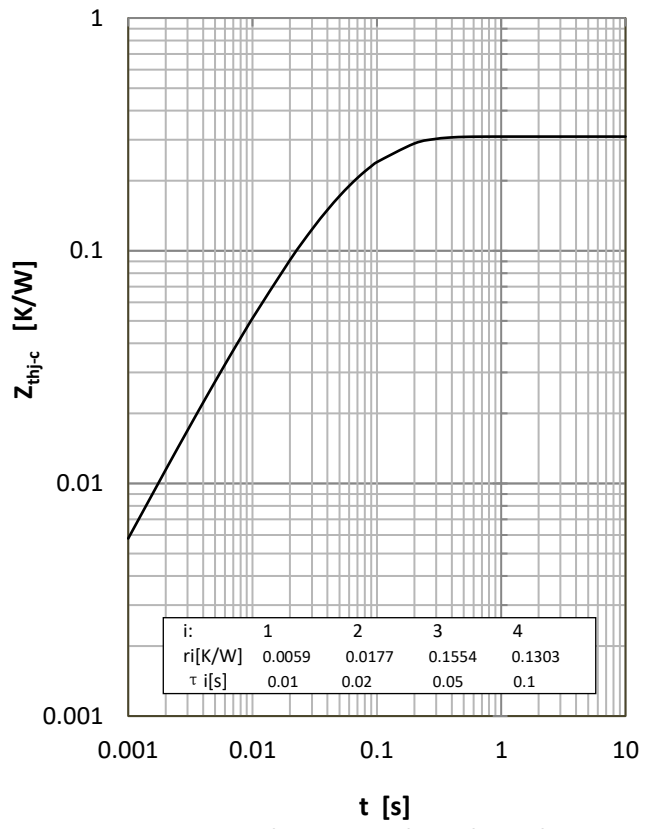
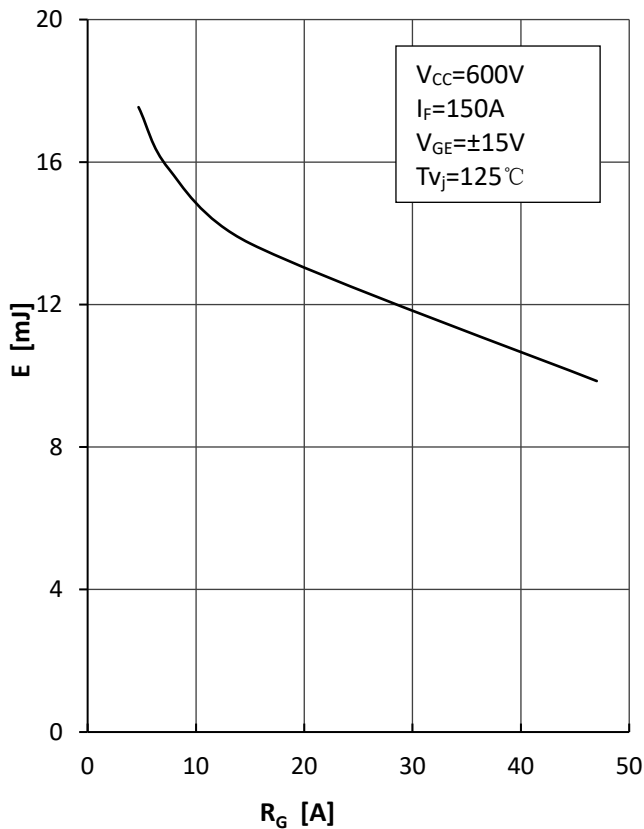
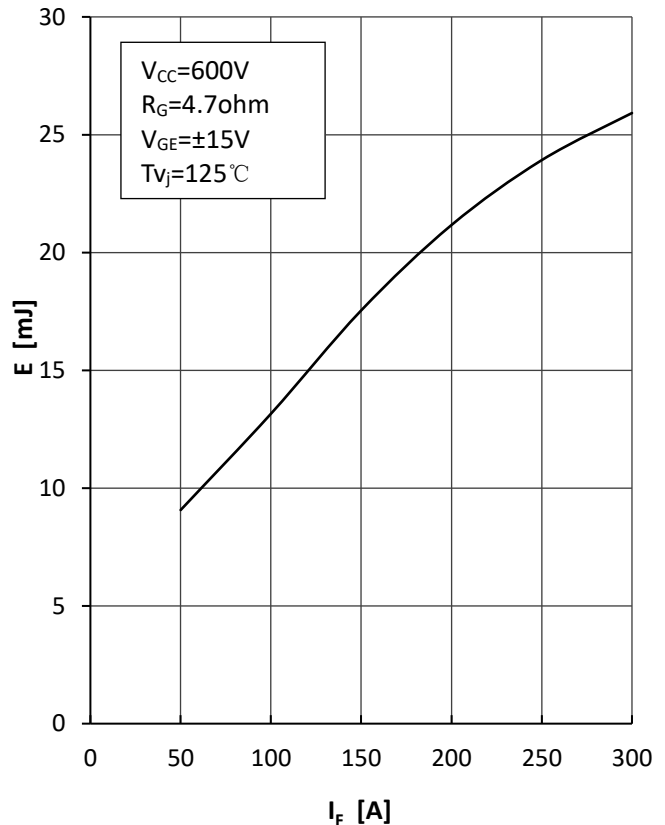
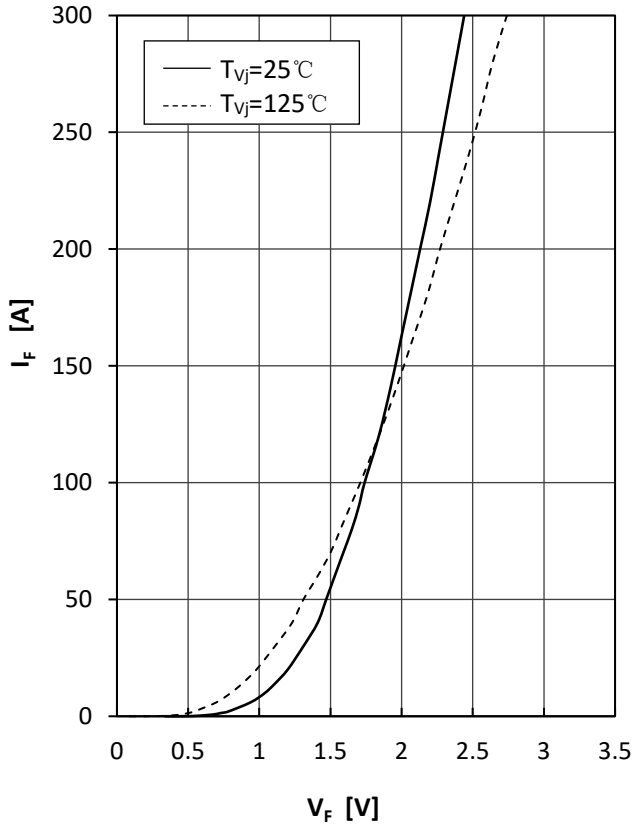

Fig 6. IGBT Transient Thermal Impedance

Curve Characteristics



Package Dimensions

C2

Dimensions in mm

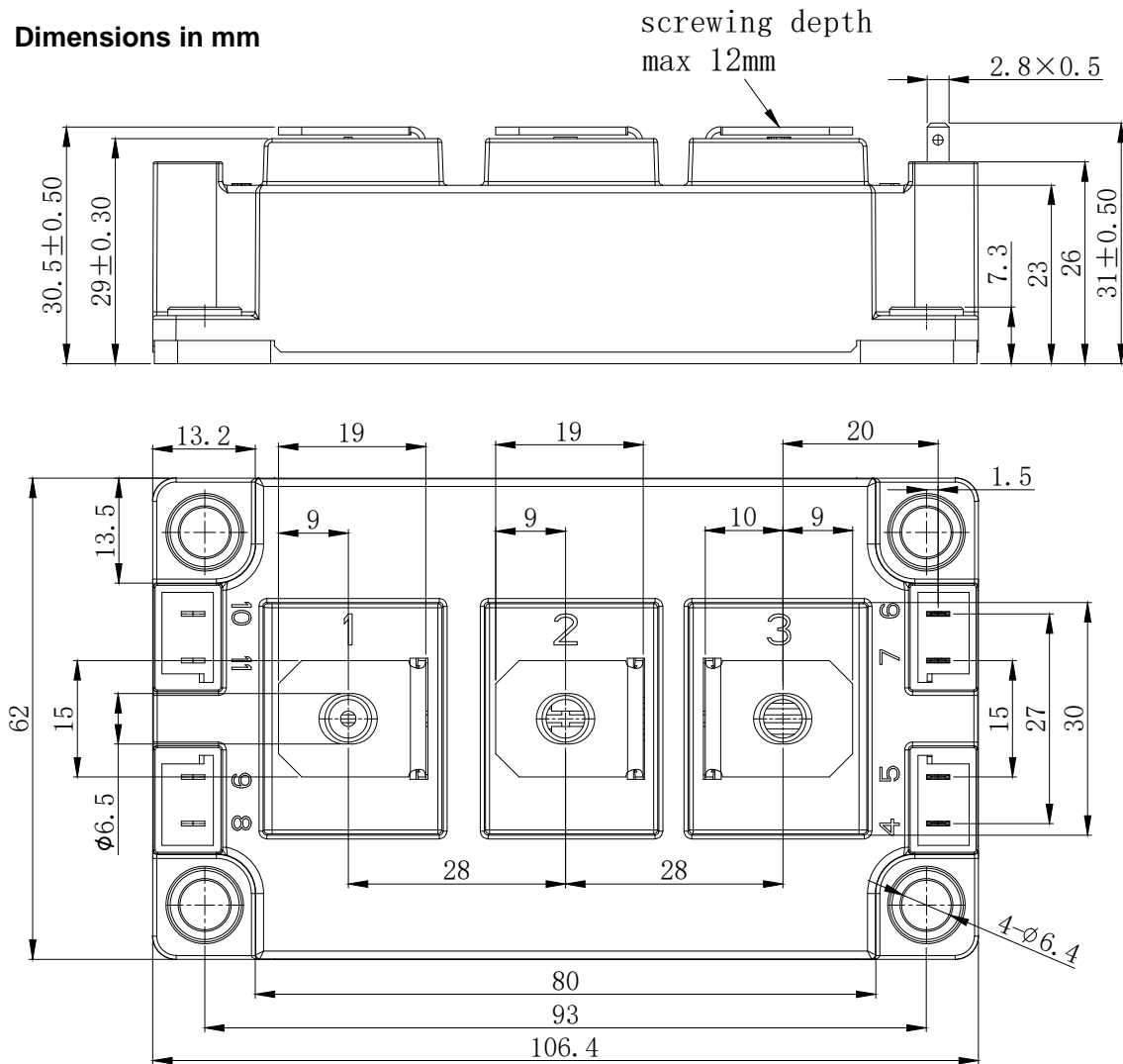

Ordering Information

Device	Packing
Part Number-BP	Bulk: 8pcs/Box ; 48pcs/Ctn

*****IMPORTANT NOTICE*****

Micro Commercial Components Corp. reserves the right to make changes without further notice to any product herein to make corrections, modifications, enhancements, improvements, or other changes. **Micro Commercial Components Corp.** does not assume any liability arising out of the application or use of any product described herein; neither does it convey any license under its patent rights, nor the rights of others. The user of products in such applications shall assume all risks of such use and will agree to hold **Micro Commercial Components Corp.** and all the companies whose products are represented on our website, harmless against all damages. **Micro Commercial Components Corp.** products are sold subject to the general terms and conditions of commercial sale, as published at <https://www.mccsemi.com/Home/TermsAndConditions>.

*****LIFE SUPPORT*****

MCC's products are not authorized for use as critical components in life support devices or systems without the express written approval of Micro Commercial Components Corporation.

*****CUSTOMER AWARENESS*****

Counterfeiting of semiconductor parts is a growing problem in the industry. Micro Commercial Components (MCC) is taking strong measures to protect ourselves and our customers from the proliferation of counterfeit parts. MCC strongly encourages customers to purchase MCC parts either directly from MCC or from Authorized MCC Distributors who are listed by country on our web page cited below. Products customers buy either from MCC directly or from Authorized MCC Distributors are genuine parts, have full traceability, meet MCC's quality standards for handling and storage. **MCC will not provide any warranty coverage or other assistance for parts bought from Unauthorized Sources.** MCC is committed to combat this global problem and encourage our customers to do their part in stopping this practice by buying direct or from authorized distributors.

单击下面可查看定价，库存，交付和生命周期等信息

[>>MCC\(美微科\)](#)