



# SS32F THRU SS3200F

Reverse Voltage - 20 to 200 Volts Forward Current - 3.0 Ampere

## SURFACE MOUNT SCHOTTKY BARRIER RECTIFIER

### Features

- ◆ The plastic package carries Underwriters Laboratory Flammability Classification 94V-0
- ◆ For surface mounted applications
- ◆ Metal silicon junction, majority carrier conduction
- ◆ Low power loss, high efficiency
- ◆ Built-in strain relief, ideal for automated placement
- ◆ High forward surge current capability
- ◆ High temperature soldering guaranteed: 260 °C/10 seconds at terminals

SMAF

ROHS COMPLIANT

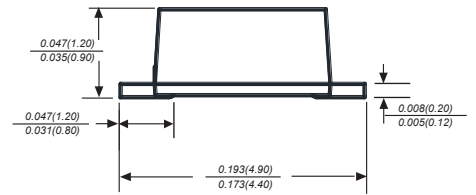
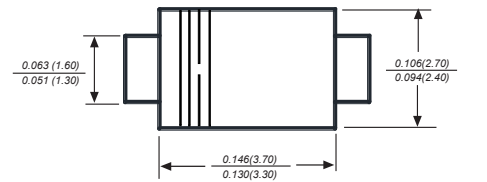

Dimensions in inches and (millimeters)

### Mechanical Data

Case: JEDEC SMAF molded plastic body  
 Terminals: Solderable per MIL-STD-750, Method 2026  
 Polarity: Color band denotes cathode end  
 Mounting Position: Any  
 Weight: 0.0018 ounce, 0.064 grams

### Maximum Ratings And Electrical Characteristics

Ratings at 25°C ambient temperature unless otherwise specified.

Single phase half-wave 60Hz, resistive or inductive load, for capacitive load current derate by 20%.

Parameter	SYMBOLS	SS32F	SS33F	SS34F	SS35F	SS36F	SS38F	SS310F	SS3150F	SS3200F	UNITS
		MDD SS32F	MDD SS33F	MDD SS34F	MDD SS35F	MDD SS36F	MDD SS38F	MDD SS310F	MDD SS3150F	MDD SS3200F	
Maximum repetitive peak reverse voltage	V <sub>RMM</sub>	20	30	40	50	60	80	100	150	200	V
Maximum RMS voltage	V <sub>RMS</sub>	14	21	28	35	42	56	70	105	140	V
Maximum DC blocking voltage	V <sub>DC</sub>	20	30	40	50	60	80	100	150	200	V
Maximum average forward rectified current at TL (see fig.1)	I <sub(av)< sub=""></sub(av)<>	3.0									A
Peak forward surge current 8.3ms single half sine-wave superimposed on rated load (JEDEC Method)	I <sub>FSM</sub>	80									A
Maximum instantaneous forward voltage at 3.0A	V <sub>F</sub>	0.55			0.70		0.85		0.95		V
Maximum DC reverse current at rated DC blocking voltage	I <sub>R</sub>	0.5						0.2		mA	
		20.0				10		2.0			
Typical junction capacitance (NOTE 1)	C <sub>J</sub>	500			300						pF
Typical thermal resistance (NOTE 2)	R <sub>θJA</sub>	55.0									°C/W
Operating junction temperature range	T <sub>J</sub>	-55 to +125									°C
Storage temperature range	T <sub>STG</sub>	-55 to +150									°C

- Note:**
1. Measured at 1.0MHz and applied reverse voltage of 4.0V D.C.
  2. P.C.B. mounted with 2.0x2.0" (5.0x5.0cm) copper pad areas.
  3. The typical data above is for reference only.



# SS32F THRU SS3200F

Reverse Voltage - 20 to 200 Volts Forward Current - 3.0 Ampere

## Typical Characteristics

AVERAGE FORWARD RECTIFIED CURRENT, AMPERES

FIG. 1- FORWARD CURRENT DERATING CURVE

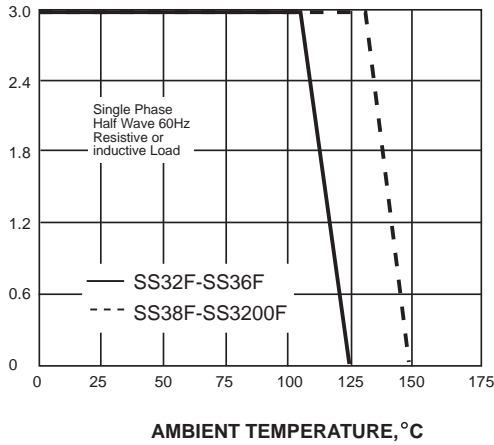

PEAK FORWARD SURGE CURRENT, AMPERES

FIG. 2-MAXIMUM NON-REPETITIVE PEAK FORWARD SURGE CURRENT

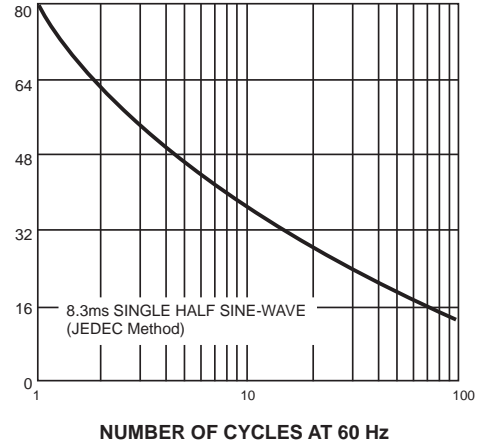
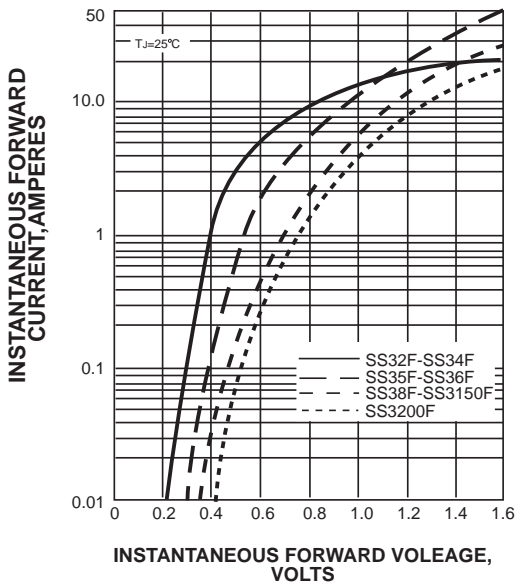

FIG. 3-TYPICAL INSTANTANEOUS FORWARD CHARACTERISTICS



INSTANTANEOUS REVERSE CURRENT, MILLIAMPERES

FIG. 4-TYPICAL REVERSE CHARACTERISTICS

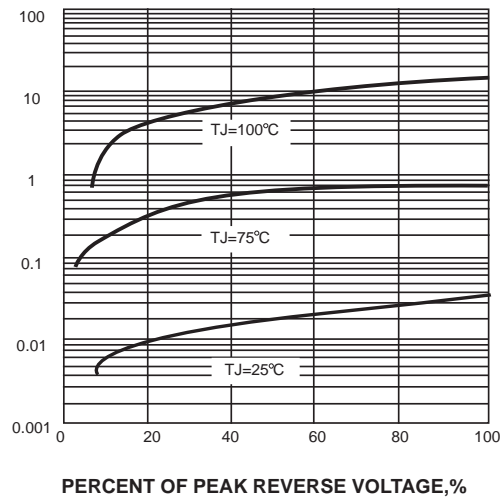
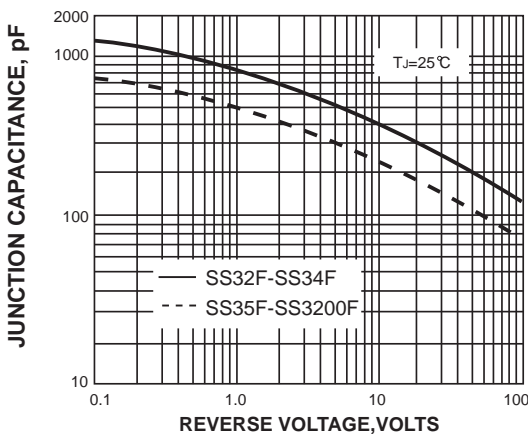
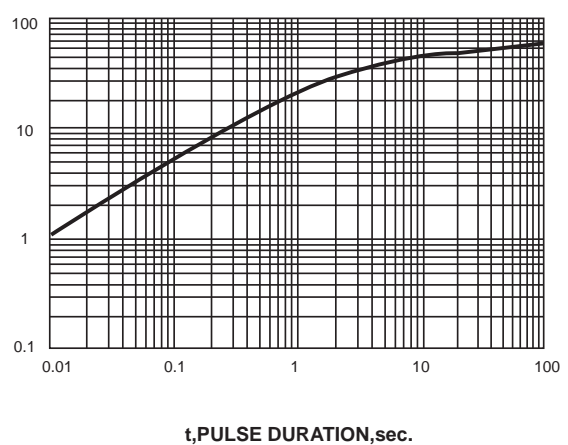

FIG. 5-TYPICAL JUNCTION CAPACITANCE



TRANSIENT THERMAL IMPEDANCE, °C/W

FIG. 6-TYPICAL TRANSIENT THERMAL IMPEDANCE



The curve above is for reference only.



# SS32F THRU SS3200F

Reverse Voltage - 20 to 200 Volts Forward Current - 3.0 Ampere

## Packing information

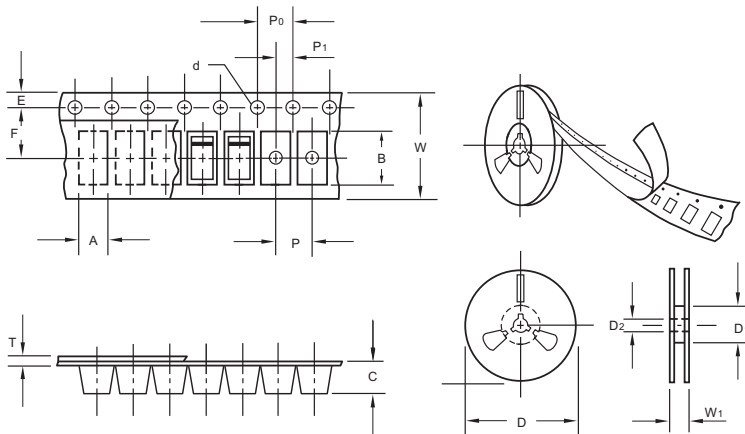

unit:mm

Item	Symbol	Tolerance	SMAF
Carrier width	A	0.1	2.80
Carrier length	B	0.1	4.75
Carrier depth	C	0.1	1.42
Sprocket hole	d	0.05	1.50
7" Reel outside diameter	D	2.0	178.00
7" Reel inner diameter	D1	min	54.40
Feed hole diameter	D2	0.5	13.00
Sprocket hole position	E	0.1	1.75
Punch hole position	F	0.1	5.05
Punch hole pitch	P	0.1	4.00
Sprocket hole pitch	P0	0.1	4.00
Embossment center	P1	0.1	2.00
Overall tape thickness	T	0.1	0.30
Tape width	W	0.3	8.00
Reel width	W1	1.0	12.30

Note: Devices are packed in accordance with EIA standard RS-481-A and specifications listed above.

## Reel packing

PACKAGE	REEL SIZE	REEL (pcs)	COMPONENT SPACING (m/m)	BOX (pcs)	INNER BOX (m/m)	REEL DIA, (m/m)	CARTON SIZE (m/m)	CARTON (pcs)	APPROX. GROSS WEIGHT (kg)
SMAF	7"	3,000	4.0	6,000	210*208*203	178	400*265*400	120,000	10.0

## Suggested Pad Layout

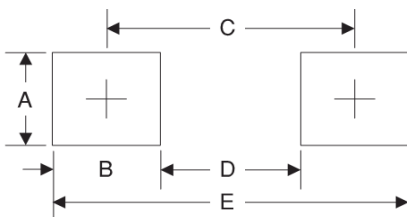

Symbol	Unit (mm)	Unit (inch)
A	1.8	0.071
B	1.6	0.063
C	3.8	0.150
D	2.2	0.087
E	5.4	0.213

## Important Notice and Disclaimer

Microdiode Electronics (Jiangsu) reserves the right to make changes to this document and its products and specifications at any time without notice. Customers should obtain and confirm the latest product information and specifications before final design, purchase or use.

Microdiode Electronics (Jiangsu) makes no warranty, representation or guarantee regarding the suitability of its products for any particular purpose, nor does Microdiode Electronics (Jiangsu) assume any liability for application assistance or customer product design. Microdiode Electronics (Jiangsu) does not warrant or accept any liability with products which are purchased or used for any unintended or unauthorized application.

No license is granted by implication or otherwise under any intellectual property rights of Microdiode Electronics (Jiangsu).

Microdiode Electronics (Jiangsu) products are not authorized for use as critical components in life support devices or systems without express written approval of Microdiode Electronics (Jiangsu).

单击下面可查看定价，库存，交付和生命周期等信息

[>>MDD\(辰达行\)](#)