



苏州敏芯微电子技术股份有限公司  
MEMSensing Microsystems (Suzhou, China) Co., Ltd.

# Data Sheet

V 1.9 / Dec. 2018

MSM261D4030H1R

PDM digital output MEMS microphone with Multi-modes

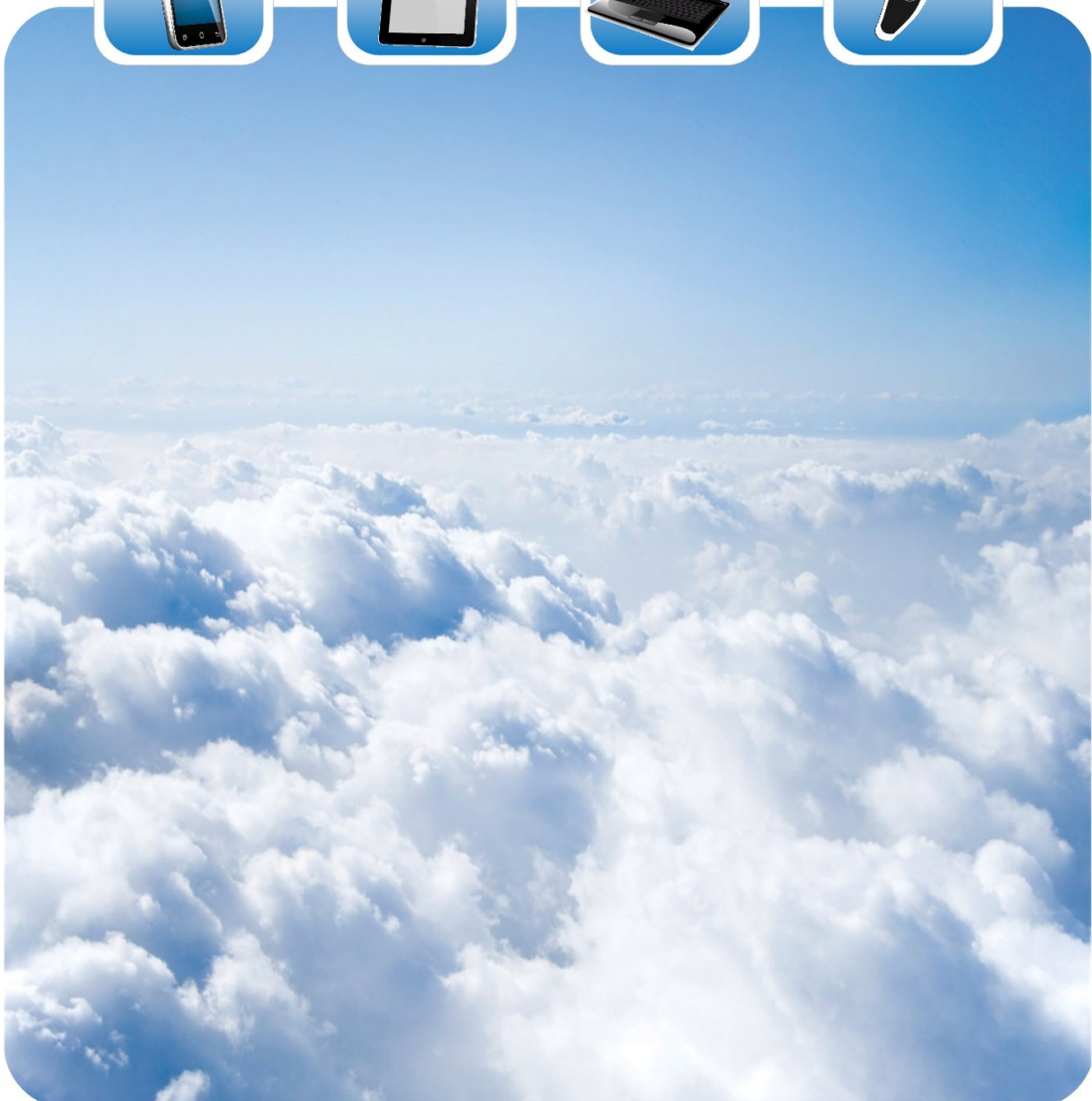

# MSM261D4030H1R

PDM digital output MEMS microphone



## GENERAL DESCRIPTION

MSM261D4030H1R is an omnidirectional, Top-ported, PDM digital output MEMS microphone. It has high performance and reliability.

MSM261D4030H1R is available in a thin 4 mm × 3 mm × 1.05 mm metal cap LGA package. It is SMT compatible with no sensitivity degradation.

## APPLICATIONS

- ✧ Mobile Phone
- ✧ Laptop
- ✧ Tablet computer
- ✧ Bluetooth headset
- ✧ Earphone
- ✧ Wearable intelligent equipment

## FEATURES

- ✧ Cost effective
- ✧ Fourth-order  $\Sigma$ - $\Delta$  modulator
- ✧ Digital PDM output
- ✧ Compatible with Sn/Pb and Pb-free solder processes
- ✧ RoHS/Halogen free compliant
- ✧ Multiple performance modes (Sleep, Low-Power, Standard Performance)
- ✧ Sensitivity Matching within +/-1dB

## PRODUCT VIEW

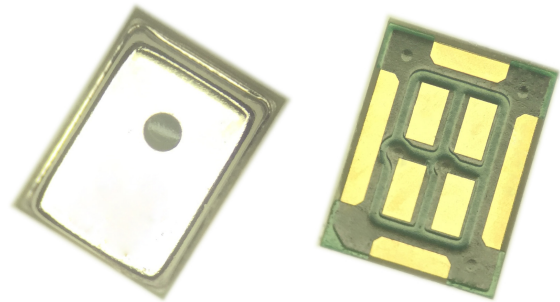



## ABSOLUTE MAXIMUM RATINGS

Parameter	Maximum value	Unit
Supply Voltage	-0.3 to 4.0	V
Sound Pressure Level	140	dB SPL
Storage temperature	-40 to 100	°C

## ACOUSTIC & ELECTRICAL SPECIFICATIONS

TEST CONDITIONS: 23 ±2°C, 55±20% R.H., VDD=1.8 V, fCLOCK=2.4 MHz, L/R pin grounded, no load, unless otherwise indicate

### General Microphone Specifications

Parameter	Symbol	Conditions	Min	Typ	Max	Units
Supply Voltage	V <sub>DD</sub>		1.6	-	3.6	V
Clock Frequency Range	Sleep Mode		0		50	KHz
	Low-Power Mode		150		900	KHz
	Standard Performance Mode		1.1		4.0	MHz
Sleep Current	I <sub>SLEEP</sub>	f <sub>CLOCK</sub> ≤ 50 kHz	-	1		μA
DC Output		Fullscale = ±100	-	4	-	% FS
Directivity			Omnidirectional			
Polarity		Increasing sound	Increasing density of 1's			
Data Format			½ Cycle PDM			
Short Circuit Current	I <sub>SC</sub>	Grounded DATA pin	1	-	10	mA
Output Load	C <sub>LOAD</sub>		-	-	200	pF
Fall-asleep Time		f <sub>CLOCK</sub> ≤ 50 kHz	-	-	30	ms
Wake-up Time		f <sub>CLOCK</sub> ≥ 151 kHz	-	-	200	ms
Power-up Time		V <sub>DD</sub> ≥ V(min)	-	6	20	ms
Mode-Change Time			-	-	10	ms

**MSM261D4030H1R**  
PDM digital output MEMS microphone

 苏州敏芯微电子技术股份有限公司  
MEMSensing Microsystems (Suzhou, China) Co., Ltd.



**Standard Performance Mode**

TEST CONDITIONS:  $f_{\text{CLOCK}} = 2.4 \text{ MHz}$ ,  $V_{\text{DD}} = 1.8 \text{ V}$ , unless otherwise indicated

Parameter	Symbol	Conditions	Min	Typ	Max	Units
Supply Current	$I_{\text{DD}}$	$f_{\text{CLOCK}} = 2.4 \text{ MHz}$	-	670	-	$\mu\text{A}$
Sensitivity	S	94 dB SPL @ 1 kHz	-27	-26	-25	dBFS
Signal to Noise Ratio	SNR	20 kHz bandwidth, A-weighted $f_{\text{CLOCK}} = 2.4 \text{ MHz}$	-	59	-	dB(A)
Total Harmonic Distortion	THD	94 dB SPL @ 1 kHz, S = Typ	-	0.1	-	%
Acoustic Overload Point	AOP	10% THD @ 1 kHz, S = Typ	-	122	-	dB SPL
Power Supply Rejection Ratio	PSRR	200 mVpp sinewave @ 1 kHz	-	50	-	dBV/FS
Power Supply Rejection	PSR+N	100 mVpp square wave @ 217 Hz, A-weighted	-	-80	-	dBFS(A)



**Low-Power Mode**

TEST CONDITIONS:  $f_{\text{CLOCK}}=768\text{ kHz}$ ,  $V_{\text{DD}}=1.8\text{ V}$ , unless otherwise indicated

Parameter	Symbol	Conditions	Min	Typ	Max	Units
Supply Current	$I_{\text{DD}}$	$f_{\text{CLOCK}}=768\text{KHz}$	-	290	-	$\mu\text{A}$
Sensitivity	S	94 dB SPL @ 1 kHz	-26	-25	-24	dBFS
Signal to Noise Ratio	SNR	94 dB SPL @ 1 kHz, A-weighted(20Hz-8KHz)	-	57	-	dB(A)
Total Harmonic Distortion	THD	94 dB SPL @ 1 kHz, S = Typ	-	0.1	-	%
Acoustic Overload Point	AOP	10% THD @ 1 kHz, S = Typ	-	122	-	dB SPL
Power Supply Rejection Ratio	PSRR	200 mVpp sinewave @ 1 kHz	-	50	-	dBV/FS
Power Supply Rejection	PSR+N	100 mVpp square wave @ 217 Hz, A-weighted(20Hz-8KHz)	-	-80	-	dBFS(A)

**Microphone Interface Specifications**

Parameter	Symbol	Conditions	Min	Typ	Max	Units
Logic Input High	$V_{\text{IH}}$		$0.7 \times V_{\text{DD}}$	-	3.6	V
Logic Input Low	$V_{\text{IL}}$		-0.3	-	$0.3 \times V_{\text{DD}}$	V
Logic Output High	$V_{\text{OH}}$	$I_{\text{OUT}} = 2\text{ mA}$	$V_{\text{DD}} - 0.45$	-	-	V
Logic Output Low	$V_{\text{OL}}$	$I_{\text{OUT}} = 2\text{ mA}$	-	-	0.45	V
Clock Duty Cycle		-	40	-	60	%



### MICROPHONE STATE DIAGRAM

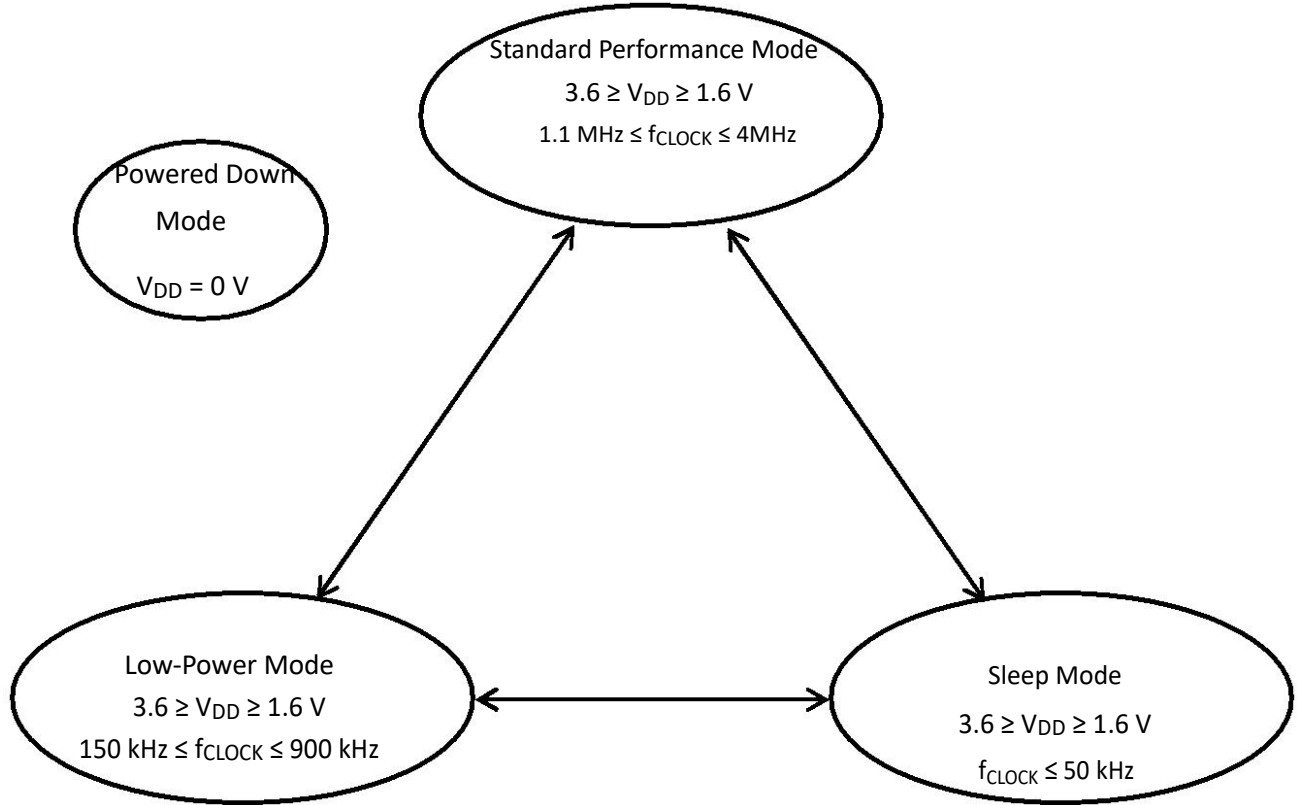



### TYPICAL FREQUENCY RESPONSE

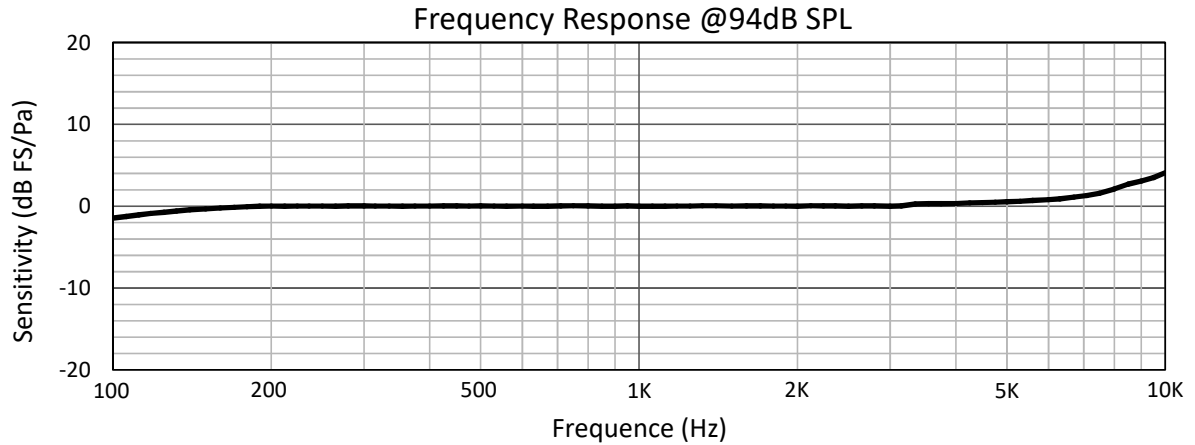

### TIMING DIAGRAM

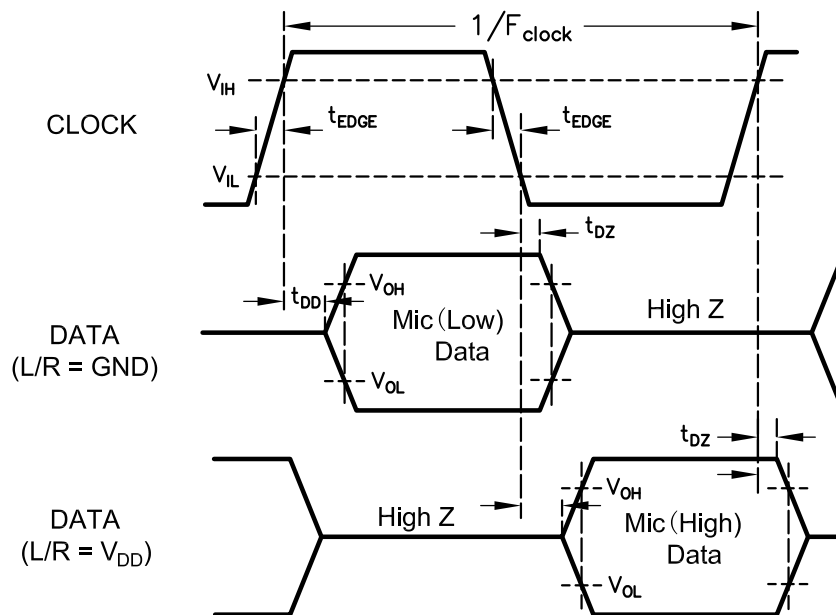

Parameter	Symbol	Min	Typ	Max
Clock Rise/Fall Time	$t_{EDGE}$	-	-	20ns
Delay Time to High Z	$t_{DZ}$	-	-	40ns
Delay Time to Data Line Driven	$t_{DD}$	-	-	50ns

Microphone	L/R	Asserts DATA on	Latch DATA on
Mic(Low)	Ground	CLK rising edge	CLK falling edge
Mic(High)	Vdd	CLK falling edge	CLK rising edge



**SMT Parameters:**

**1. Recommend PCB land pattern layout: (unit: mm)**

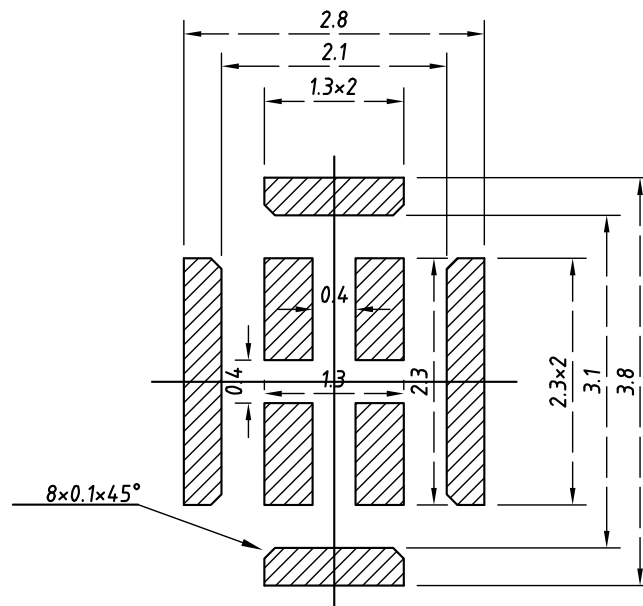





2. Recommend reflow profile:

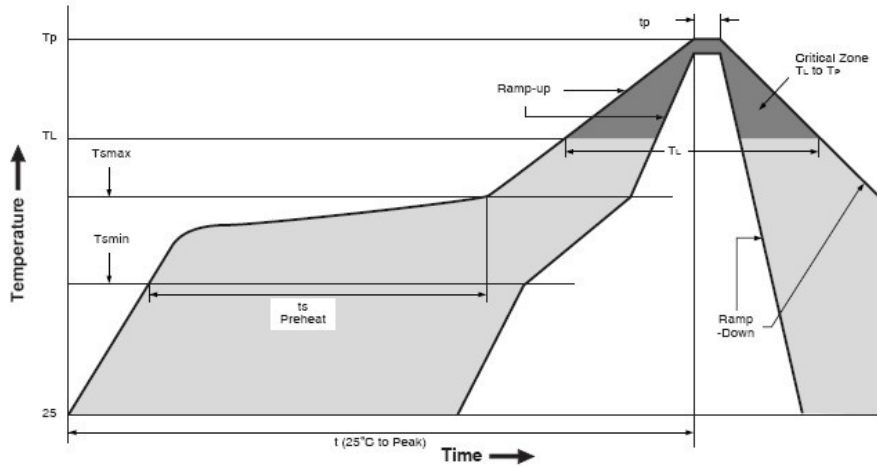

Description	Parameter	Pb-free
Average ramp rate	$T_L$ to $T_P$	3 °C/sec max
Preheat		
Minimum temperature	$T_{SMIN}$	150 °C
Maximum temperature	$T_{SMAX}$	200 °C
Time( $T_{SMIN}$ to $T_{SMAX}$ )	$t_s$	60 sec to 120 sec
Ramp-up rate	$T_{SMAX}$ to $T_L$	1.25 °C/sec max
Time maintained above liquidous temperature	$t_L$	60 sec to 150 sec
Liquidous temperature	$T_L$	217 °C
Peak temperature	$T_P$	260 °C max
Time within 5°C of actual peak temperature	$t_p$	20 sec to 40 sec
Ramp-down rate	$T_L$ to $T_P$	6 °C/sec max
Time 25 °C ( $t_{25\text{ °C}}$ ) to peak temperature	$t$	8 minutes max



OUTLINE DIMENSIONS AND PIN DEFINITION:

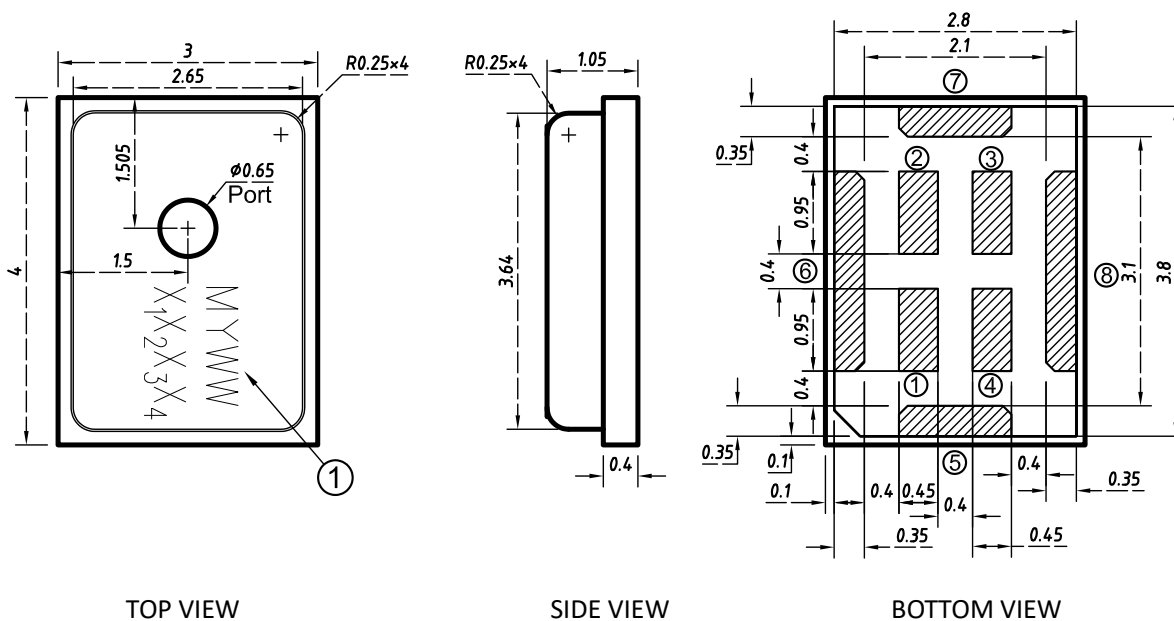
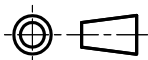

TOP VIEW

SIDE VIEW

BOTTOM VIEW

PIN function description

PIN#	Function
1	VDD
2	L/R
3	CLK
4	DATA
5,6,7,8	GND

Item	Dimension	Tolerance
Length (L)	4.00	±0.10
Width (W)	3.00	±0.10
Height (H)	1.05	±0.10
Acoustic Port (AP)	Ø0.65	±0.05

Dimensions are in millimeters, tolerance is ±0.15mm unless otherwise specified.

MYWW X <sub>1</sub> X <sub>2</sub> X <sub>3</sub> X <sub>4</sub>	M	Memsensing
	Y	Year(A~Z)
	WW	Week
	X <sub>1</sub> X <sub>2</sub> X <sub>3</sub> X <sub>4</sub>	Serial Number



## **ADDITIONAL NOTES**

(A) MSL (moisture sensitivity level) Class 1.

(B) Maximum of 3 reflow cycles is recommended.

I In order to minimize device damage:

Do not board wash or clean after the reflow process.

Do not brush board with or without solvents after the reflow process.

Do not directly expose to ultrasonic processing, welding, or cleaning.

Do not insert any object in port hole of device at any time.

Do not apply air pressure into the port hole.

Do not pull a vacuum over port hole of the microphone.

## **STORAGE AND TRANSPORTATION**

(A) Keep MEMS MIC in warehouse with less than 75% humidity and without sudden temperature change, acid air, any other harmful air or strong magnetic field.

Recommend floor life (out of bag) at factory no more than 4 weeks.

(B) The MEMS MIC with normal pack can be transported by ordinary conveyances. Please protect products against moist, shock, sunburn and pressure during transportation.

## **MATERIALS STATEMENT**

Meet the requirements of MEMSensing standard on hazard substances control (including RoHS2.0+REACH+Halogen-Free, etc.), with "HSF" identification on label.



**PACKAGING & MARKING DETAIL:**

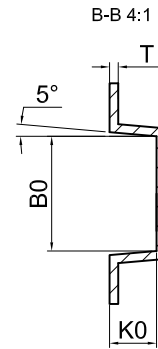
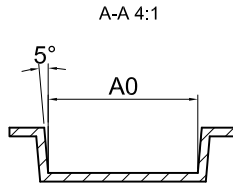
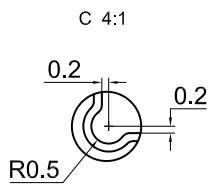
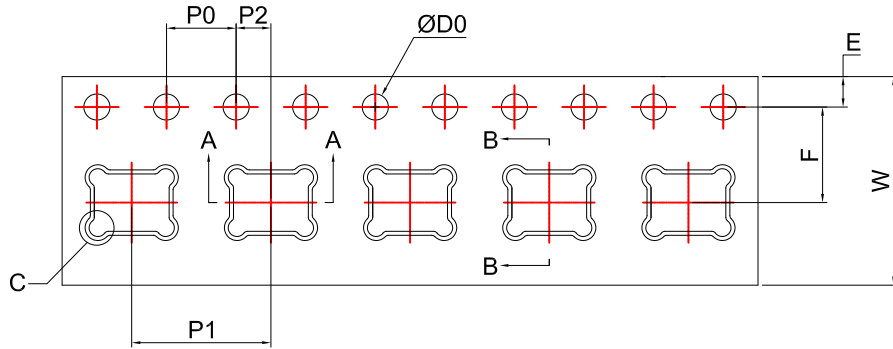

Direction of Feed →

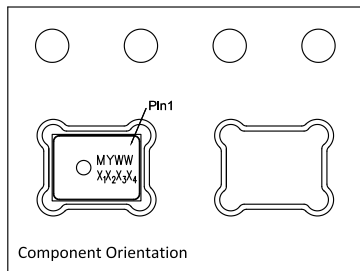

ITEM	W	E	F	ØD0	K0
DIM(mm)	12.00±0.30	1.75±0.10	5.50±0.10	1.50 <sup>+0.10</sup> <sub>0</sub>	1.35±0.10
ITEM	P0	10P0	P1	A0	B0
DIM(mm)	4.00±0.10	40.00±0.20	8.00±0.10	4.30±0.10	3.30±0.10
ITEM	P2	T			
DIM(mm)	2.00±0.10	0.25±0.05			

**Note:**

- 1) Dimensions are in mm;
- 2) Don't put the vacuum suction nozzle alignment the port hole;
- 3) Tape & Reel Per EIA-481 standard;
- 4) Label applied to external package and direct to reel;
- 5) Static voltage <100V;

Model Number	Reel Diameter	Quantity Per Reel
MSM261D4030H1R	13 inch	5700



**RECOMMENDED INTERFACE CIRCUIT:**

**Figure 1. MSM261D4030H1R electrical connections**

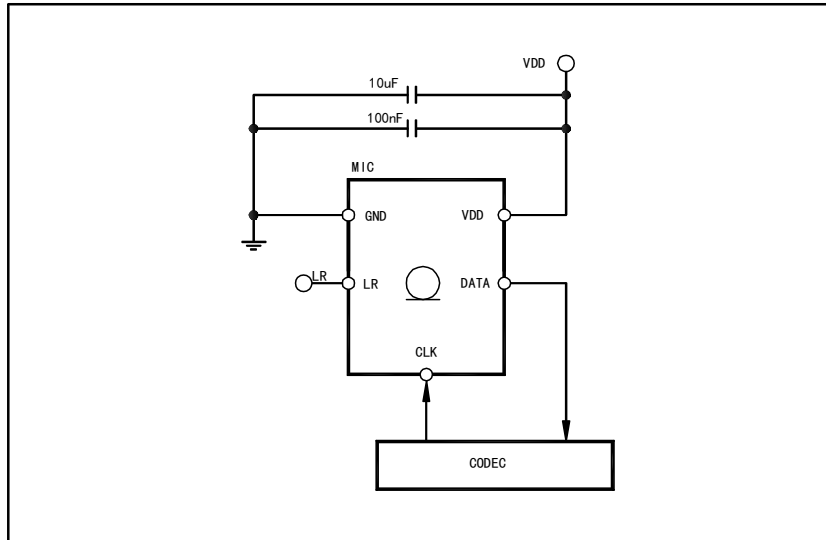

**Figure 2. Electrical connections for stereo configurations**

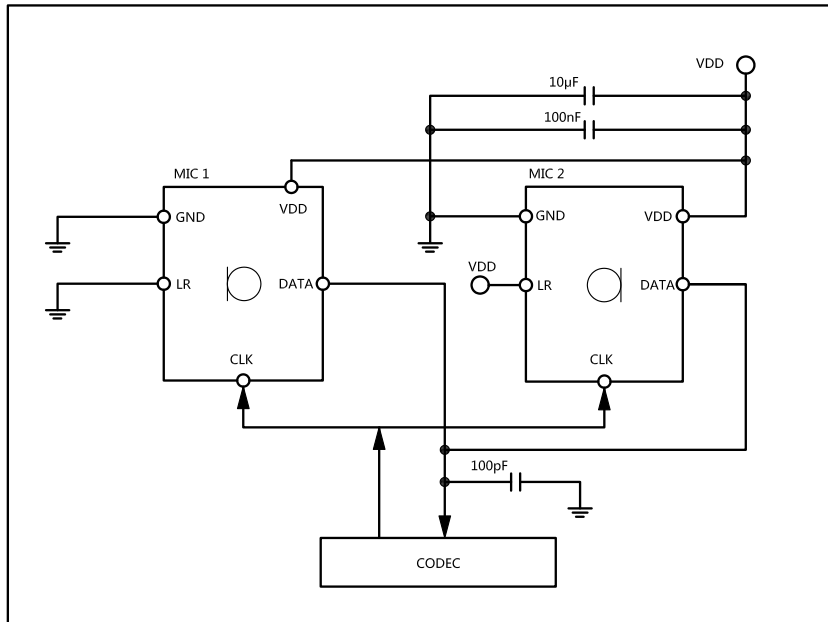

Power supply decoupling capacitors (100nF ceramic, 10µF ceramic) should be placed as near as possible to VDD of the device. (common design practice)



## RELIABILITY SPECIFICATIONS

Test	Description
Thermal Shock	100 cycles air-to-air thermal shock from -40°C to +125°C with 15 minute soaks.
High Temperature Storage	1,000 hours at +105°C environment
Low Temperature Storage	1,000 hours at -40°C environment
Reflow	5 reflow cycles with peak temperature of +260°C
ESD-HBM	3 discharges of ±2 kV direct contact to I/O pins.
ESD- LID-GND	3 discharges of ±8 kV direct contact to lid while unit is grounded.
ESD-MM	3 discharges of ±200V direct contact to I/O pins.
Vibration	4 cycles of 20 to 2,000 Hz sinusoidal sweep with 20 G peak acceleration lasting 12 minutes in X, Y and Z directions.
Mechanical Shock	3 pulses of 10,000 G in the X, Y and Z direction
High Temperature Bias	1,000 hours at +105°C under bias
Low Temperature Bias	1,000 hours at -40°C under bias
Temperature/Humidity Bias	1,000 hours at +85°C/85% R.H. under bias.
Drop Test	To be no interference in operation after dropped to 1.0cm steel plate 18 times from 1.5 meter height

**NOTE:** Sensitivity should vary within ±3dB from initial sensitivity. (The measurement to be done after 2 hours of conditioning at 20±2 °C, R.H 60%~70%)

**MSM261D4030H1R**  
PDM digital output MEMS microphone



**REVISION HISTORY:**

Revision	Subjects (major changes since last revision)	Date
0.8	Preliminary Edition	2017-02-15
1.0	Initial Release	2017-04-28
1.1	Modified the Interface Circuit	2017-07-11
1.2	Update packaging detail	2017-10-24
1.3	Modified Power-up Time	2018-01-29
1.4	Update Timing diagram	2018-05-21
1.5	Update Marking rule	2018-06-22
1.6	Update outline dimensions	2018-08-08
1.7	Update the typical of SNR	2018-08-22
1.8	Update the typical of SNR	2018-09-17
1.9	Update the typical of THD	2018-12-29

**公司销售、技术支持联系方式**

(<http://www.memsensing.com>)

For English:

**MEMSensing Microsystems(Suzhou,China)**  
Co. Ltd.

No. 99 Jinji Lake Avenue, Bldg. NW-09, Suite 501  
Suzhou Industrial Park, China 215123

Phone: +86 512 62956055

Fax: +86 512 62956056

中文用户:

苏州敏芯微电子技术股份有限公司

苏州工业园区金鸡湖大道 99 号, NW-09 楼, 501 室  
中国 215123

电话: +86 512 62956055

传真: +86 512 62956056

**Disclaimer:** specifications and characteristics are subject to change without notice. MEMSensing Microsystems Co. Ltd. assumes no liability to any customer, licensee or any third party for any damages or any kind of nature whatsoever related to using this technical data.

单击下面可查看定价，库存，交付和生命周期等信息

[>>MEMSensing\(敏芯微\)](#)