



Low power consumption, Low ESR Cap. Compatible ME6206B Series

General Description

ME6206B series are highly precise, low power consumption, high voltage, positive voltage regulators manufactured using CMOS and laser trimming technologies. The series provides large currents with a significantly small dropout voltage.

The series is compatible with low ESR ceramic capacitors. The current limiter's foldback circuit also operates as a short protect for the output current limiter and the output pin.

Features

- Maximum Output Current: 250mA
($V_{IN}=4.3V, V_{OUT}=3.3V$)
- Dropout Voltage: 0.2V at 100mA, 0.4V at 200mA
($V_{OUT}=3.3V$)
- Input Voltage Range: up to 5.5V
- Highly Accuracy: $\pm 2\%$
- Low Power Consumption: 7uA (TYP.)
- Excellent Input Stability
- Be available to regulator and reference voltage

Typical Application

- Mobile phones
- communication equipment
- Portable games
- Cameras, Video systems
- Reference voltage sources
- Battery powered equipment

Package

- SOT23

Typical Application Circuit

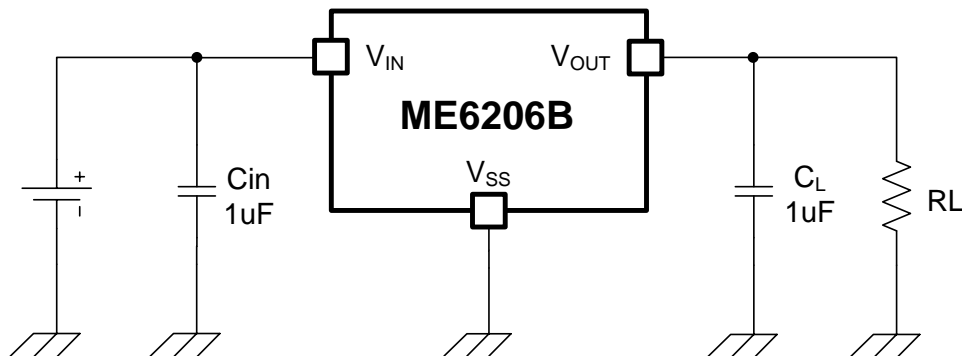

Selection Guide

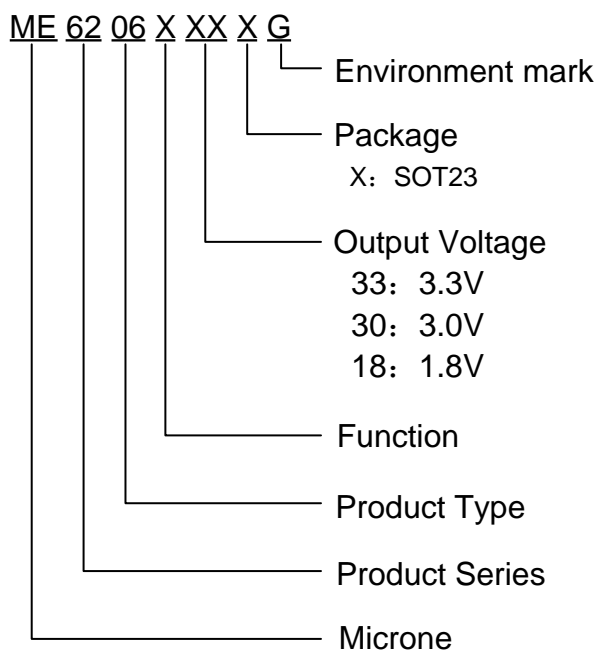

product series	Output voltage	Supply Current	Package
ME6206B33XG	3.3V	7uA	SOT23
ME6206B30XG	3.0V	7uA	SOT23
ME6206B18XG	1.8V	7uA	SOT23

NOTE: At present ,There are three kinds of voltage: 3.3V、3.0V、1.8V; If you need other voltage or package, please contact our sales staff.

Pin Configuration

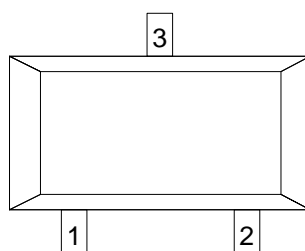

SOT23

Pin Assignment

Pin Num	Name	Function
1	V _{SS}	Ground
2	V _{OUT}	Output
3	V _{IN}	Input

Block Diagram

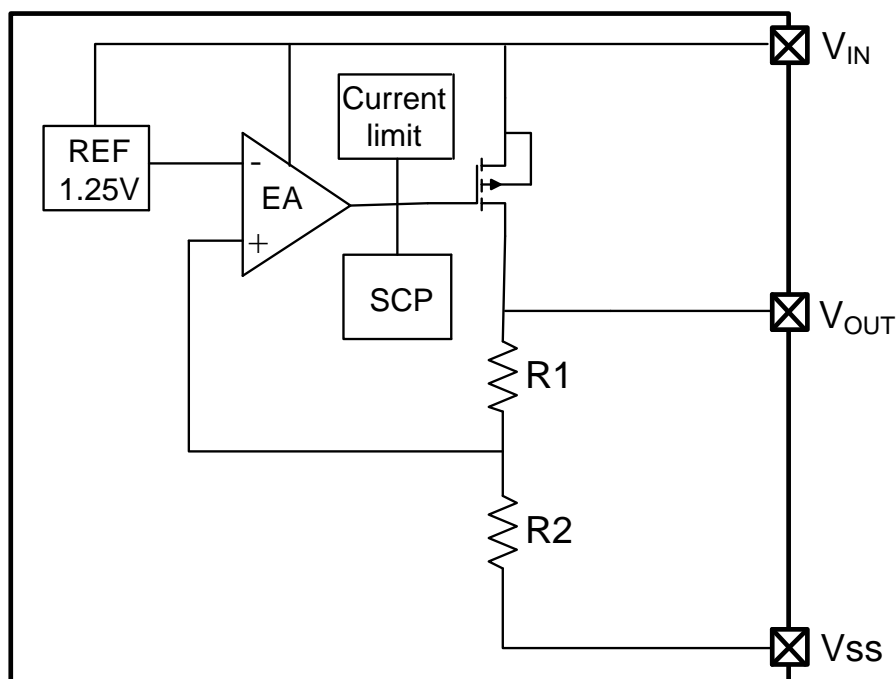

Absolute Maximum Ratings

Parameter	Symbol	Description	Units
Input Voltage	V_{IN}	6.5	V
Output Current	I_{out}	500	mA
Output Voltage	V_{out}	$V_{SS}-0.3 \sim V_{out}+0.3$	V
Power Dissipation	SOT23 P_d	0.38	W
Thermal resistance (Junction to air)	SOT23 θ_{JA}	328	$^{\circ}C/W$
Operating Ambient Temperature	T_{Opr}	-40 ~ +85	$^{\circ}C$
Storage Temperature	T_{stg}	-55 ~ +150	$^{\circ}C$
Maximum junction temperature	T_J	-40 ~ +150	$^{\circ}C$

Electrical Characteristics

($V_{IN}=V_{out}+1V, C_{in}=C_{out}=1\mu F, T_a=25^{\circ}C$ Unless otherwise stated)

Parameter	Symbol	Condition	Mix	Typ	Max	Unit	
Output Voltage	$V_{OUT}(E)$ (Note 2)	$I_{OUT}=10mA,$ $V_{IN}=V_{out}+1V$	X 0.98	$V_{OUT}(T)$ (Note 1)	X 1.02	V	
Input Voltage	V_{IN}		-	-	5.5	V	
Maximum Output Current	$I_{OUT} (max)$	$V_{IN}=V_{out}+1V$	-	250	-	mA	
Load Regulation	ΔV_{OUT}	$V_{IN}=V_{out}+1V,$ $1mA \leq I_{OUT} \leq 100mA$	-	14	28	mV	
Dropout Voltage (Note 3)	V_{dif1}	I_{OUT} $=100mA$	$V_{out}=1.8V$	-	310	620	mV
			$V_{out}=3.0V、3.3V$	-	200	400	mV
	V_{dif2}	I_{OUT} $=200mA$	$V_{out}=1.8V$	-	620	1240	mV
			$V_{out}=3.0V、3.3V$	-	400	800	mV
Supply Current	I_{SS}	$V_{IN}=V_{out}+1V$	-	7	15	μA	
Line Regulations	$\frac{\Delta V_{OUT}}{\Delta V_{IN} \cdot V_{OUT}}$	$I_{OUT} = 10mA$ $V_{out}+1V \leq V_{IN} \leq 5V$	-	0.03	0.2	%/V	
Power Supply Ripple Rejection Ratio	PSRR	$V_{in} = 5V$ $+1V_{rmsAC},$ $I_{OUT} = 10mA$	$f=100Hz$	-	70	-	dB
			$f=1kHz$	-	65	-	
			$f=10kHz$	-	54	-	
Short Circuit Current	I_{short}	$V_{in}=V_{out}(T)+1.5V$ $V_{out}=V_{ss}$	-	20	50	mA	
Over Current Protection	I_{limit}		-	480	-	mA	

Note : 1. $V_{OUT}(T)$: Specified Output Voltage

2. $V_{OUT}(E)$: Effective Output Voltage (i.e. The output voltage when " $V_{OUT}(T)+1.0V$ " is provided at the V_{in} pin while maintaining a certain I_{out} value.)

3. V_{dif} : $V_{IN1} - V_{OUT}(E)'$

V_{IN1} : The input voltage when $V_{OUT}(E)'$ appears as input voltage is gradually decreased.

$V_{OUT}(E)'$ = A voltage equal to 98% of the output voltage whenever an amply stabilized I_{out} ($V_{OUT}(T)+1.0V$) is input.

Type Characteristics

(1) Output Voltage VS. Output Current ($V_{IN}=V_{out}+1$, $T_a = 25\text{ }^\circ\text{C}$)

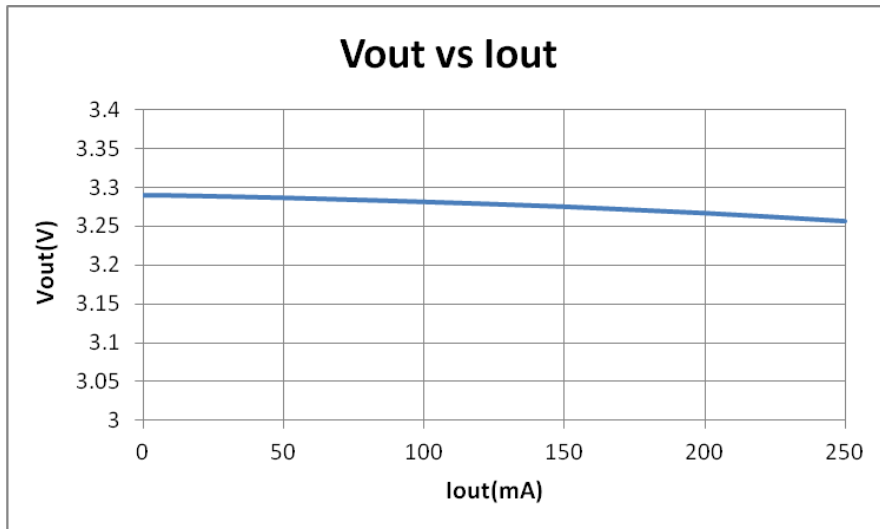

(2) Output Voltage vs Input Voltage ($T_a = 25\text{ }^\circ\text{C}$)

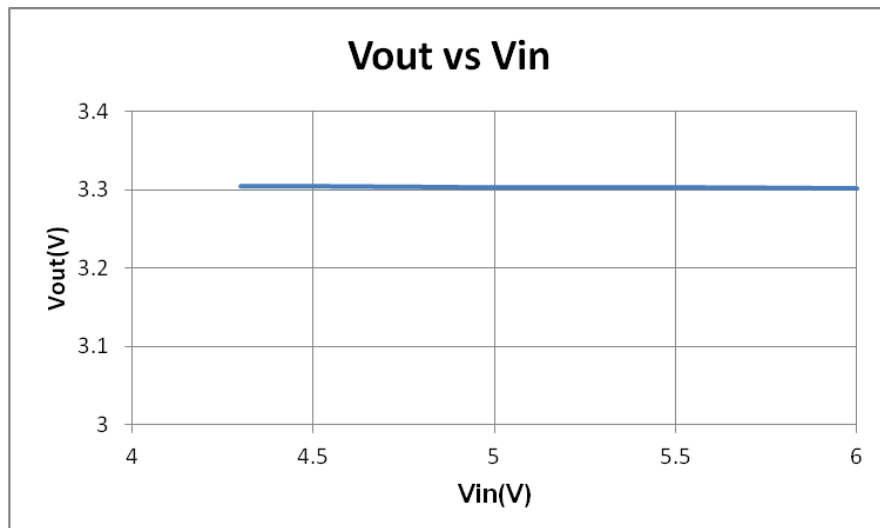

(3) Dropout Voltage vs Output Current ($V_{IN}=V_{out}+1V$, $T_a = 25\text{ }^\circ\text{C}$)

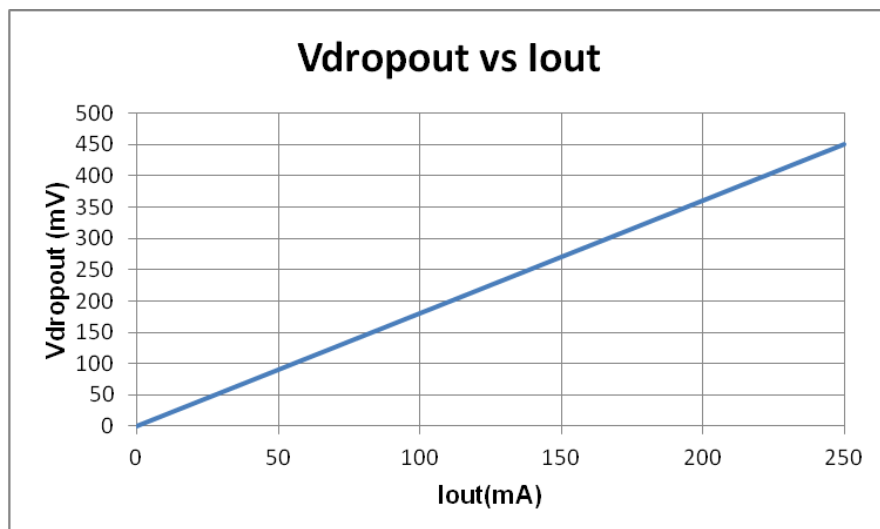

(4) Supply Current vs Input Voltage ($T_a = 25\text{ }^\circ\text{C}$)

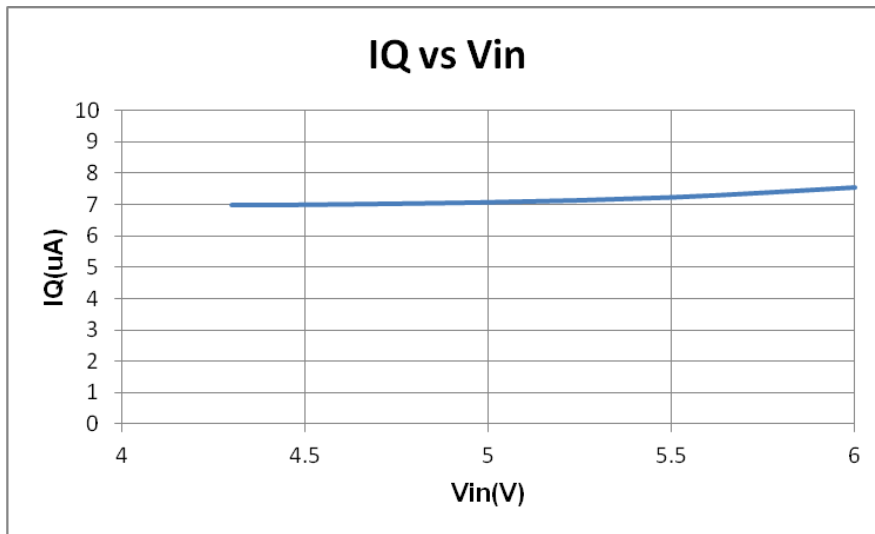

(5) Output Voltage vs Temperature ($V_{IN}=4.3\text{V}, I_{out}=10\text{mA}$)

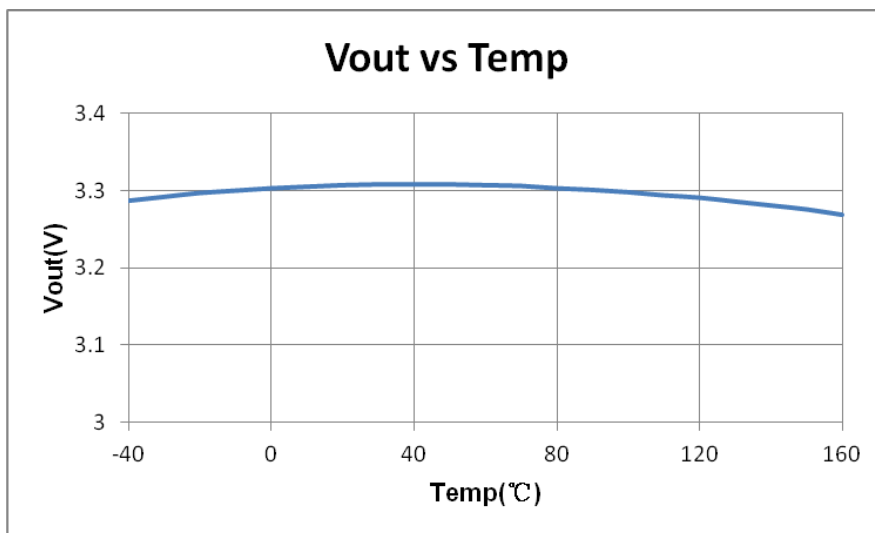

(6) Ilimit & short circuit ($V_{IN}=4.3\text{V}$)

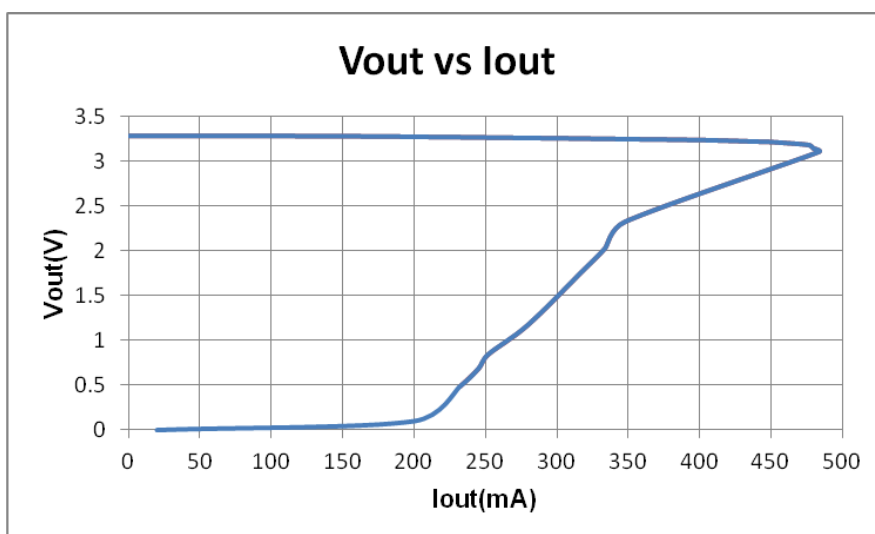

(7) overshoot (VIN=4.3V, Iout=0)

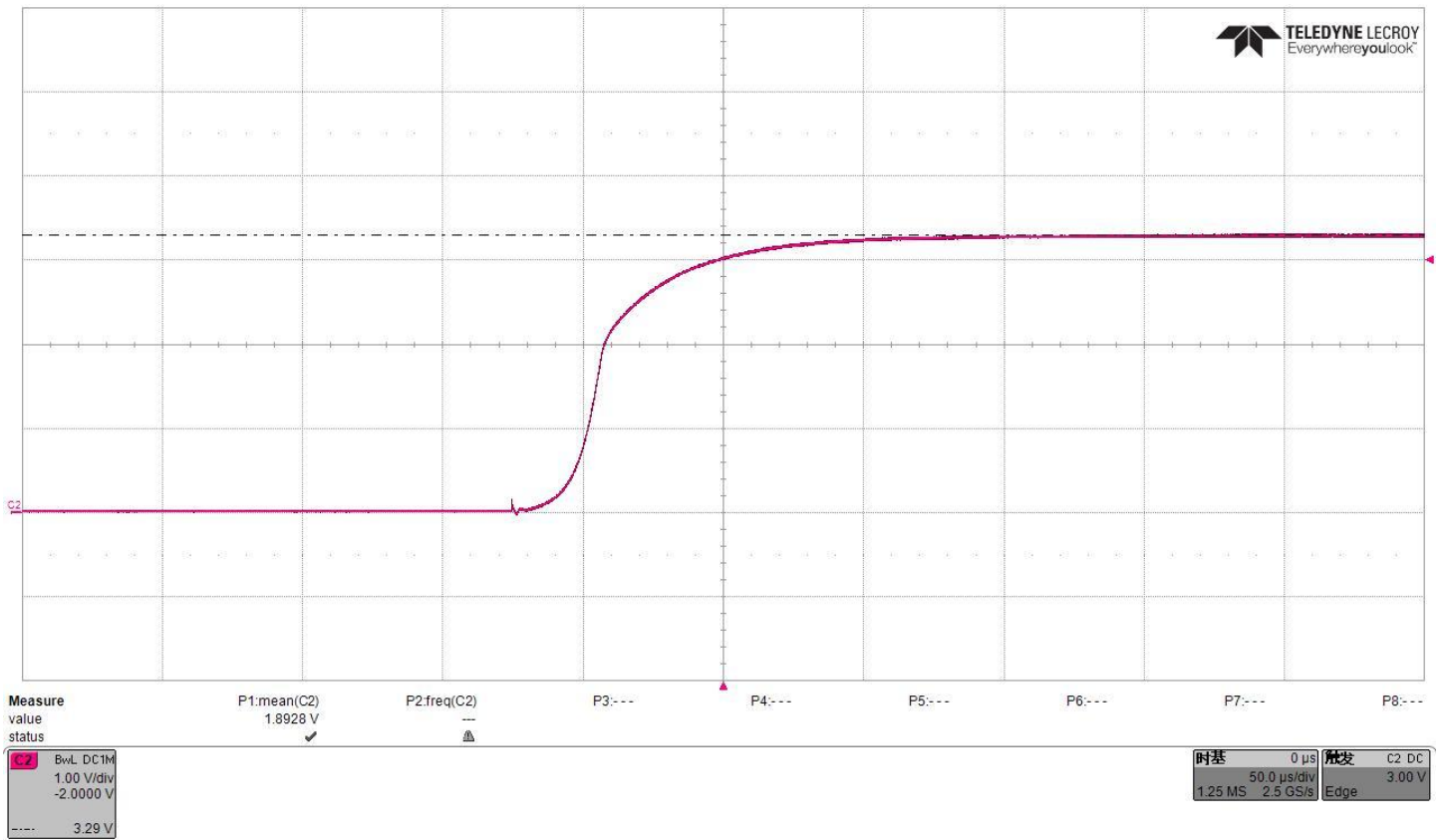

(8) Load Transient (VIN=4.3V, Iout=1mA ↔ 250mA)

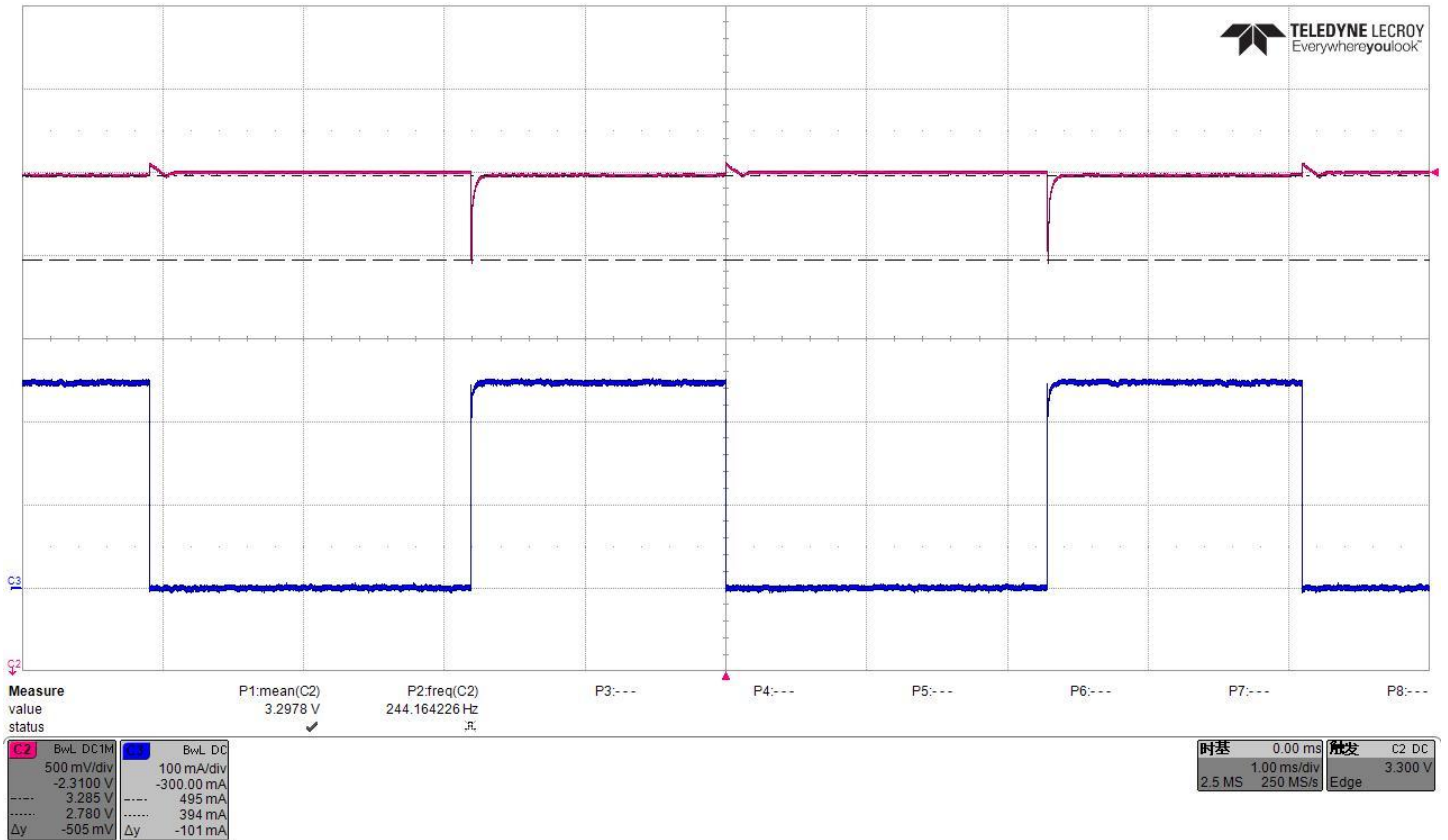

Packaging Information

- Package Type: SOT23

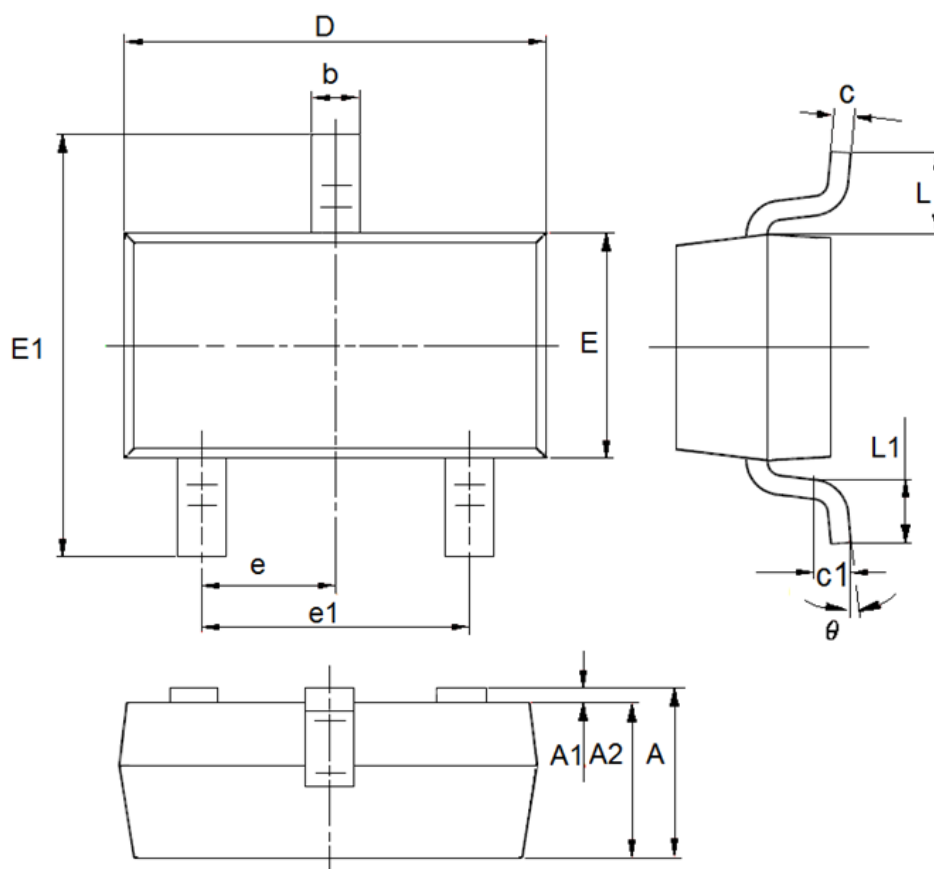

DIM	Millimeters		Inches	
	Min	Max	Min	Max
A	0.9	1.15	0.0354	0.0453
A1	0	0.14	0	0.0055
A2	0.9	1.05	0.0354	0.0413
b	0.28	0.52	0.011	0.0205
c	0.07	0.23	0.0028	0.0091
D	2.8	3	0.1102	0.1181
e1	1.8	2	0.0709	0.0787
E	1.2	1.4	0.0472	0.0551
E1	2.2	2.6	0.0866	0.1024
e	0.95(TYP)		0.0374(TYP)	
L	0.55(TYP)		0.0217(TYP)	
L1	0.25	0.55	0.0098	0.0217
θ	0	8°	0	8°
c1	0.25(TYP)		0.0098(TYP)	

- The contents of this document will be updated with the product's improvement without prior notice. Please consult our sales staff before using this document to ensure that you are using the latest version.
- The application circuit examples described in this document are only used to indicate the representative use of the product and do not guarantee the design of mass production.
- Please use this product within the limits stated in this document. We will not be responsible for any damage caused by improper use.
- The products described in this document are not allowed to be used in equipment or devices that affect the human body without the written permission of our company, including but not limited to: health equipment, medical equipment, disaster prevention equipment, fuel control equipment, automobile equipment, aviation equipment and vehicle equipment.
- Although our company has always been committed to improving product quality and reliability, semiconductor products have a certain probability of malfunction or wrong work. To prevent personal injury or property damage caused by such accidents, please pay full attention to safety design, for example: Alternate design, fire protection design, and prevention of wrong action design.
- When exporting this product or this document overseas, you should abide by applicable import and export control laws.
- Copying or reprinting part or all of this document in any form without the permission of our company is strictly prohibited.

单击下面可查看定价，库存，交付和生命周期等信息

[>>MICRONE\(南京微盟\)](#)