

MEMS digital pressure sensor

Ultra-low-power high performance capacitance pressure sensor

Key Features

- Pressure sensor with the calibrated pressure range : 1000hPa-5000hPa
- Relative accuracy:
- Absolute accuracy:
- Build-in high precision temperature sensor
- SPI / I2C serial interface
- Supply voltage: 1.71V-3.6V
- Current consumption:2.5uA@1Hz forced mode
- Ultra low power-down current (< 0.1uA@25°C)
- Package : 2.0mm x 2.5mm x 1.1mm 10-PIN LGA metal-lid
- Operation temperature from -40 °C to 85 °C

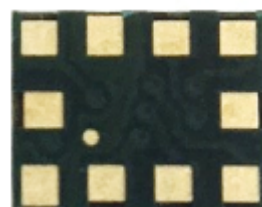

Applications

- Enhancement of GPS navigation
- Indoor navigation(Floor detection, elevator detection)
- Outdoor navigation, leisure and sports applications
- Weather forecast
- Vertical velocity indication

Target devices

- Handsets such as mobile phones, tablet PCs, GPS devices
- Navigation systems
- Home weather stations
- Flying toys
- Watches

Product view

The da218 is an absolute barometric pressure especially designed for mobile applications. The sensor module includes a high linearity pressure sensor and an ultra-low power 24 bit $\Delta \Sigma$ ADC with internal factory calibrated coefficients. It provides a precise digital 24 Bit pressure and temperature value and different operation modes that allow the user to optimize for conversion speed and current consumption.

A high resolution temperature output allows the implementation of an altimeter/thermometer function without any additional sensor.

The sensor module is housed in an extremely compact 10-pin metal-lid LGA package with a footprint of only 2.0mm x 2.5mm and 1.1mm package height . It is guaranteed to operate over a temperature range extending from -40 °C to +85 °C. The package is holed to allow external pressure to reach the sensing element.

Content

1.	Pin description	7
1.1.	Block Diagram	7
1.2.	Pin description	8
2.	Electrical specifications	9
2.1.	Electrical characteristics	9
2.2.	Absolute maximum ratings	10
3.	Communication interface	11
3.1.	Communication interface Electrical specification	11
3.1.1.	SPI Electrical specification	11
3.1.2.	I2C Electrical specification	12
3.2.	Digital interface operation	13
3.2.1.	SPI Operation	13
3.2.2.	I2C Operation	14
4.	Functionality	16
4.1.	Terminology	16
4.1.1.	Power mode	16
4.1.2.	Current consumption	17
4.1.3.	Measurement time	17
4.1.4.	Sensor data	17
4.1.5.	Factory calibration	17
5.	Application hints	18
5.1.	Connection diagram 4-wire SPI	18
5.2.	Connection diagram 3-wire SPI	18
5.3.	Connection diagram IIC	19
6.	Register mapping	20
7.	Registers description	21
7.1.	SPI_CTRL (00H)	21
7.2.	CHIP_ID (D0H)	21
7.3.	TEMP_LSB (FCH), TEMP_CSB(FBH), TEMP_MSB (FAH)	21
7.4.	PRESS_LSB(F9H),PRESS_CSB(F8H) ,PRESS_MSB (F7H)	22
7.5.	CONFIG (F5H)	22
7.6.	CTRL_MEAS (F4H)	23
7.7.	STATUS (F3H)	23
7.8.	RESET (E0H)	24
8.	SMT Guide	25
8.1.	SMT Parameter Settings	25
8.1.1.	Printing parameters	25
8.1.2.	Reflow oven Parameters	25
9.	Package information	26
9.1.	Outline dimensions	26
9.2.	Example land pattern	27
9.3.	Tape and reel specification	28

9.3.1. Tape specification	28
10. Reliability specifications	29
11. Revision history.....	30

List of tables

Table 1. Pin description	8
Table 2. Operating Range	9
Table 3. Pressure Sensor	9
Table 4. Temperature Sensor	9
Table 5. Supply Currents Characteristics	9
Table 6. Absolute Maximum Rating	10
Table 7. Electrical specification of the SPI interface pins.....	11
Table 8. Electrical specification of the I2C interface pins	12
Table 9. Mapping of the interface pins.....	13
Table 10. W1 and W0 settings	14
Table 11. I2C Address	14
Table 12. SAD+Read/Write patterns	14
Table 13. Transfer when master is writing one byte to slave	15
Table 14. Transfer when master is writing multiple bytes to slave.....	15
Table 15. Transfer when master is receiving (reading) one byte of data from slave	15
Table 16. Transfer when master is receiving (reading) multiple bytes of data from slave	15
Table 17. Mode settings	16
Table 18. T_SB settings	16
Table 19. Current consumption	17
Table 20. Measurement time	17
Table 21. Register address map	20
Table 22. SPI_CTRL register	21
Table 23. SPI_CTRL description.....	21
Table 24. CHIP_ID register	21
Table 25. TEMP_LSB register	21
Table 26. TEMP_CSB register	21
Table 27. TEMP_MSB register.....	21
Table 28. PRESS_LSB register	22
Table 29. PRESS_CSB register	22
Table 30. PRESS_MSB register	22
Table 31. CONFIG register.....	22
Table 32. CONFIG description.....	22
Table 33. CTRL_MEAS register	23
Table 34. CTRL_MEAS register description.....	23
Table 35. STATUS register	23
Table 36. MOTION_FLAG register description.....	23
Table 37. RESET register	24
Table 38. RESET register description	24
Table 39. Printing parameters	25
Table 40. Reflow oven Parameters	25
Table 41. Mange Parameter	25
Table 42. Accelerated Life Tests	29

Table 43. Component Level Tests29
Table 44. Document revision history30

List of figures

Figure 1. Block Diagram.....	7
Figure 2. Pin description.....	8
Figure 3. SPI slave timing diagram.....	11
Figure 4. I2C Slave timing diagram.....	12
Figure 5. Instruction Phase Bit Field.....	13
Figure 6. MSB First and LSB First Instruction and Data Phases.....	14
Figure 7. I2C Protocol.....	15
Figure 8. 4-wire SPI interface circuit.....	18
Figure 9. 3-wire SPI interface circuit.....	18
Figure 10. IIC interface circuit.....	19
Figure 11. Mechanical data and package dimensions.....	26
Figure 12. Example land pattern.....	27
Figure 13. Tape and reel dimension in mm.....	28

1. Pin description

1.1. Block Diagram

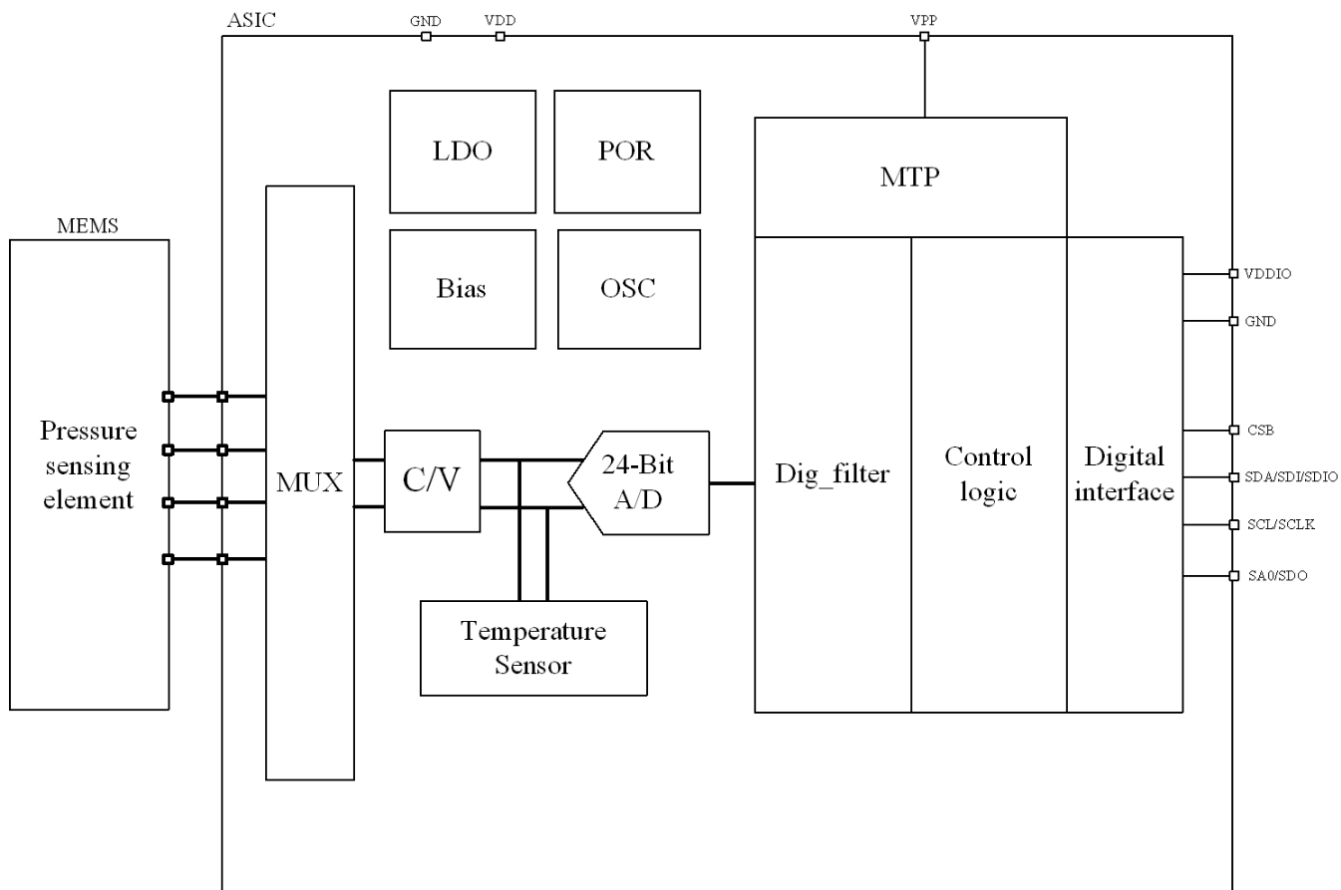
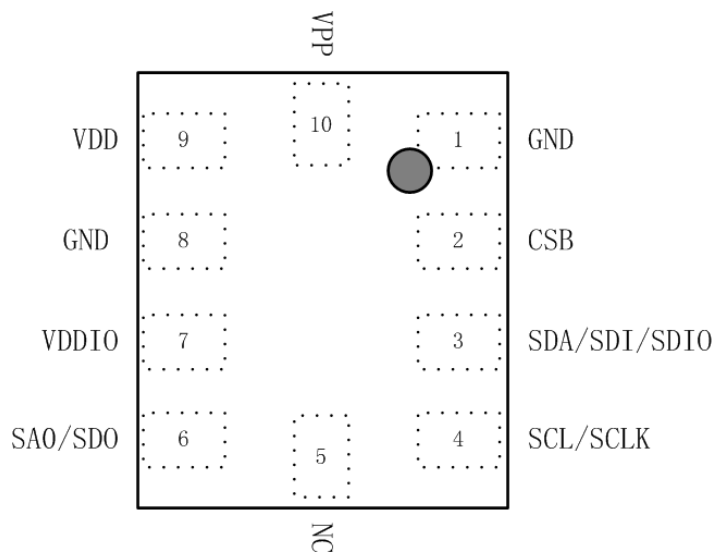

Figure 1. Block Diagram

1.2. Pin description



Top View

Figure 2. Pin description

Table 1. Pin description

Pin#	Pin Name	Type	Description
1	GND	Power supply	Ground
2	CSB	Digital input	Chip select When using the I2C communication, CSB pin must be connected to VDDIO
3	SDA/SDI/SDIO	Digital input	Serial data input/output in I2C mode (SDA) Serial data input in 4-wire SPI mode (SDI) Serial data input/output in 3-wire SPI mode (SDIO)
4	SCL/SCLK	Digital input	Serial clock input
5	NC	--	NO internal connection
6	SA0/SDO	Digital output	I2C less significant bit of the device address (SA0) When using the I2C communication: SA0 connected to VDDIO or keep floating is for default I2C Addr 0x6D SA0 connected to GND is for I2C Addr 0x6C Serial data output in 4-wire SPI mode
7	VDDIO	Power supply	Digital interface supply
8	GND	Power supply	Ground
9	VDD	Power supply	Analog supply
10	VPP	--	Test pin, keep floating

2. Electrical specifications

2.1. Electrical characteristics

T = 25 °C, 40-60% R.H. unless otherwise noted

Table 2. Operating Range

Item	Symbol	Min	Typ.	Max	Unit
Supply Voltage	VDD	1.71	3	3.6	V
	VDDIO	1.2		3.6	V
Operating Temperature	T _{operating}	-40	-	85	°C

Table 3. Pressure Sensor

Item	Symbol	Test conditions	Min	Typ.	Max	Unit
Input Pres Range	P _{in}	T = -40...85°C, Vdd=2.1...3.6V				hPa
Measurement Error	P _{Error}	T = 0...70°C, Vdd=2.1...3.6V				hPa
		T = -40...85°C, Vdd=2.1...3.6V				hPa
RAW LSB resolution	P _{LSB, RAW}	T = -40°C, Vdd=2.1...3.6V				hPa
		T = 25°C, Vdd=2.1...3.6V				hPa
		T = 85°C, Vdd=2.1...3.6V				hPa
Pressure Measurement Stability Range	P _{sta}	Minimum 95% of the measurement				hPa

Table 4. Temperature Sensor

Item	Symbol	Test conditions	Min	Typ.	Max	Unit
Measurement Range	T _R	Full accuracy				°C
Temperature Accuracy (After off-chip Calibration)	T _A	to °C			±1	°C
Temperature Noise (After off-chip Calibration)	T _N	@osr_T=OSRX1			0.01	°C

Table 5. Supply Currents Characteristics

Item	Symbol	Test conditions	Min	Typ.	Max	Unit
Supply Current @25 °C	I _{DD}	1Hz, forced mode (osr_T=001b, osr_P=001b, osr_H=000b)		2	2.5	uA
Peak Current @25 °C	I _{peak}	During conversion		505	700	uA
Sleep current @25 °C	I _{DDSL}			0.02	0.1	uA
Standby current	I _{DDSB}	inactive period of normal mode		0.9	1.3	uA
Regulator PSRR				60		dB
Storage temperature			-40		85	°C

2.2. Absolute maximum ratings

Stresses below those listed as “absolute maximum ratings” may cause permanent damage to the device. This is a stress rating only and functional operation of the device under these conditions is not implied. Exposure to maximum rating conditions for extended periods may affect device reliability.

Table 6. Absolute Maximum Rating

Item	Symbol	Test conditions	Min	Typ.	Max	Unit
Supply Voltage	VDD		-0.3		4.25	V
	VDDIO		-0.3		4.25	
Pressure Range	P _r					MPa
Temperature Range	T _r		-40		85	°C
Analog pin voltage	V _a		-0.3		VDD+0.3	V
Digital output voltage	V _{DO}		-0.3		VDDIO+0.3	V
ESD Susceptibility	HBM			±2000		V
	CDM			±500		V
	MM			±200		V
Storage temperature			-60		85	°C



This is a mechanical shock sensitive device, improper handling can cause permanent damages to the part.



This is an ESD sensitive device, improper handling can cause permanent damages to the part.

3. Communication interface

3.1. Communication interface Electrical specification

3.1.1.SPI Electrical specification

Table 7. Electrical specification of the SPI interface pins

Symbol	Parameter	Condition	Min	Max	Unit
fclk	Clock frequency	Max load on SDIO or SDO = 25pF		10	MHz
tSCKL	SLCK low pulse		20		
tSCKH	SLCK high pulse		20		
tSDI_setup	SDI setup time		20		ns
tSDI_hold	SDI hold time		20		ns
tSDO_OD	SDO/SDI output delay	Load = 25pF		30	ns
		Load = 250pF		40	ns
tCSB_setup	CSB setup time		20		ns
tCSB_hold	CSB hold time		40		ns

The figure below shows the definition of the SPI timing given in the above table:

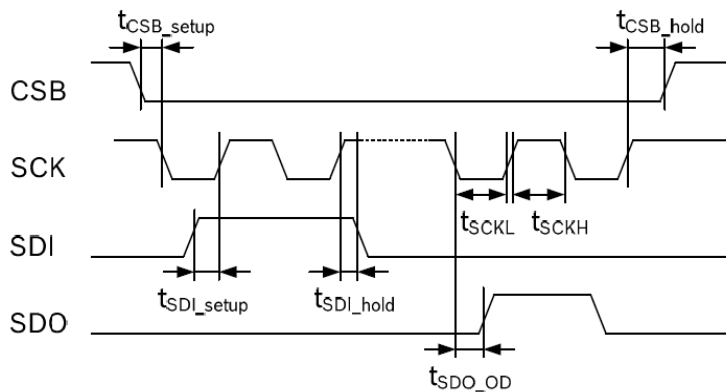

Figure 3. SPI slave timing diagram

3.1.2.I2C Electrical specification

Table 8. Electrical specification of the I2C interface pins

Symbol	Parameter	Min	Max	Unit
f _{scl}	Clock frequency		400	kHz
t _{LOW}	SCL low pulse	1.3		us
t _{HIGH}	SCL high pulse	0.6		us
t _{SUDAT}	SDA setup time	0.1		us
t _{HDDAT}	SDA hold time	0.0		us
t _{SUSTA}	Setup Time for a repeated start condition	0.6		us
t _{HDSTA}	Hold time for a start condition	0.6		us
t _{SUSTO}	Setup Time for a stop condition	0.6		us
t _{BUF}	Time before a new transmission can start	1.3		us

The figure below shows the definition of the I2C timing given in the above table:

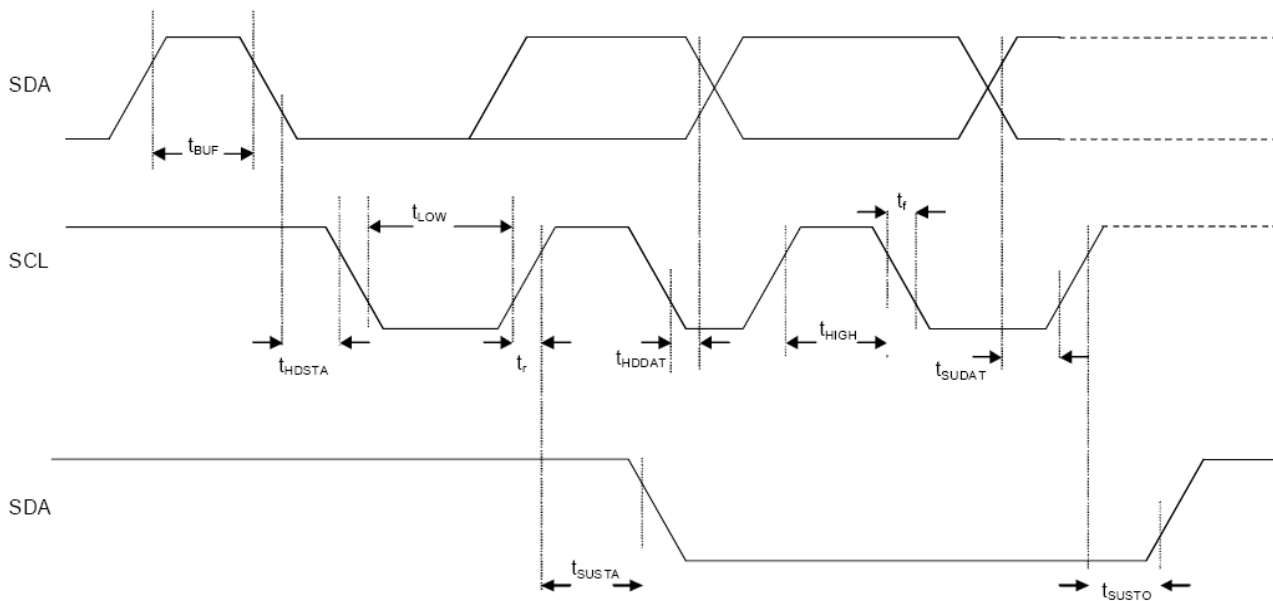

Figure 4. I2C Slave timing diagram

3.2. Digital interface operation

The da218 supports two serial digital interface protocols for communications as slave with a host device: SPI and I2C. The active interface is selected by the state of the pin CS, 0 selects SPI and 1 selects I2C. By default, SPI operates in 3-wire mode and it can be re-configured by writing 1 to bit ‘SDO_active’ to work in 4-wire mode. Both interfaces share the same pins. The mapping for each interface is given in the following table:

Table 9. Mapping of the interface pins

PIN name	I2C	SPI
SCL/SCLK	Serial clock	Serial clock
SDA/SDI	Serial Data	Data input (4-wire mode). Data input/output (3-wire mode)
SA0/SDO	Used to set LSB of I2C address	Data output (4-wire mode)
CSB	Unused	Chip select

3.2.1. SPI Operation

The falling edge of CSB, in conjunction with the rising edge of SCLK, determines the start of framing. Once the beginning of the frame has been determined, timing is straightforward. The first phase of the transfer is the instruction phase, which consists of 16 bits followed by data that can be of variable lengths in multiples of 8 bits. If the device is configured with CSB tied low, framing begins with the first rising edge of SCLK.

The instruction phase is the first 16 bits transmitted. As shown in the following figure, the instruction phase is divided into a number of bit fields.

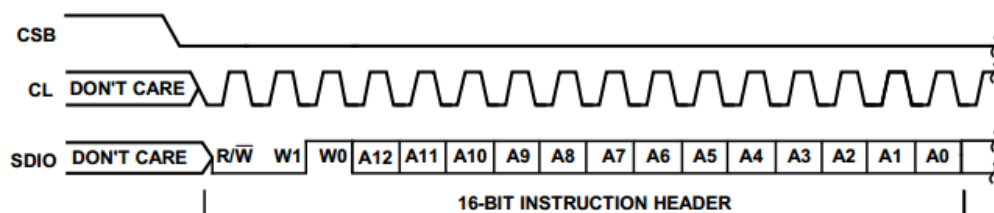

Figure 5. Instruction Phase Bit Field

The first bit in the stream is the read/write indicator bit (R/W). When this bit is high, a read is being requested, otherwise indicates it is a write operation.

W1 and W0 represent the number of data bytes to transfer for either read or write as shown in the following table (W1 and W0 setting table). If the number of bytes to transfer is three or less (00, 01, or 10), CSB can stall high on byte boundaries. Stalling on a non-byte boundary terminates the communications cycle. If these bits are 11, data can be transferred until CSB transitions high. CSB is not allowed to stall during the streaming process.

The remaining 13 bits represent the starting address of the data sent. If more than one word is being sent, sequential addressing is used, starting with the one specified, and it either increments (LSB first) or decrements (MSB first) based on the mode setting.

Table 10. W1 and W0 settings

W1:W0	Action	CSB stalling
00	1 byte of data can be transferred.	Optional
01	2 bytes of data can be transferred.	Optional
10	3 bytes of data can be transferred.	Optional
11	4 or more bytes of data can be transferred. CSB must be held low for entire sequence; otherwise, the cycle is terminated.	No

Data follows the instruction phase. The amount of data sent is determined by the word length (Bit W0 and Bit W1). This can be one or more bytes of data. All data is composed of 8-bit words.

Data can be sent in either MSB-first mode or LSB-first mode (by setting ‘LSB_first’ bit). On power up, MSB-first mode is the default. This can be changed by programming the configuration register. In MSB-first mode, the serial exchange starts with the highest-order bit and ends with the LSB. In LSB-first mode, the order is reversed. The detail is shown in the below figure.

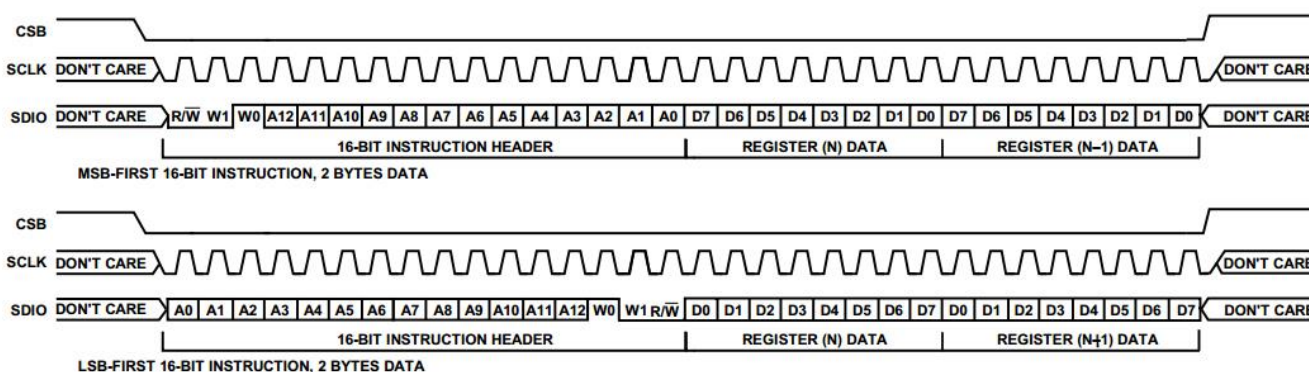

Figure 6. MSB First and LSB First Instruction and Data Phases

Register bit ‘SDO_active’ is responsible for activating SDO on devices. If this bit is cleared, then SDO is inactive and read data is routed to the SDI pin. If this bit is set, read data is placed on the SDO pin. The default for this bit is low, making SDO inactive.

3.2.2.I2C Operation

I2C bus uses SCL and SDA as signal lines. Both lines are connected to VDDIO externally via pull-up resistors so that they are pulled high when the bus is free. The I2C device address of da218 is shown below. The LSB bit of the 7bits device address is configured via SA0 pin.

Table 11. I2C Address

SAD6	SAD5	SAD4	SAD3	SAD2	SAD1	SAD0	W/R
1	1	0	1	1	0	SA0	0/1

Table 12. SAD+Read/Write patterns

Command	SAD[6:1]	SAD[0]=SA0	R/W	SAD+R/W
Read	110110	0	1	11011001(D9h)
Write	110110	0	0	11011000(D8h)
Read	110110	1	1	11011011(DBh)
Write	110110	1	0	11011010(DAh)

The I2C interface protocol has special bus signal conditions. Start (S), stop (P) and binary data conditions are shown below. At start condition, SCL is high and SDA has a falling edge. Then the slave address is sent. After the 7 address bits, the direction control bit R/W selects the read or write operation. When a slave device recognizes that it is being addressed, it should acknowledge by pulling SDA low in the ninth SCL cycle (ACK) cycle.

At stop condition, SCL is also high, but SDA has a rising edge. Data must be held stable at SDA when SCL is high. Data can change value at SDA only when SCL is low.

In order to prevent the I2C slave of the device to lock-up the I2C bus, a watchdog timer (WDT) is implemented. The WDT observes internal I2C signals and resets the I2C interface if the bus is locked-up by the sensor. The activity and the timer period of the WDT can be configured through the bits “wdt_en” and “wdt_time” of “RESOLUTION_RANGE” (0fH) register.

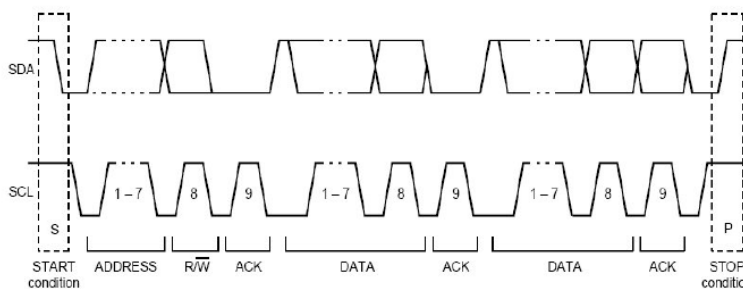

Figure 7. I2C Protocol

Table 13. Transfer when master is writing one byte to slave

Master	S	SAD+W		SUB		DATA		P
Slave			SAK		SAK		SAK	

Table 14. Transfer when master is writing multiple bytes to slave

Master	S	SAD+W		SUB		DATA		DATA		P
Slave			SAK		SAK		SAK		SAK	

Table 15. Transfer when master is receiving (reading) one byte of data from slave

Master	S	SAD+W		SUB		SR	SAD+R			NMASK	P
Slave			SAK		SAK			SAK	DATA		

Table 16. Transfer when master is receiving (reading) multiple bytes of data from slave

Master	S	SAD+W		SUB		SR	SAD+R			MAK		MAK		NMASK	P
Slave			SAK		SAK			SAK	DATA		DATA		DATA		

Note:

Symbol	Symbol explain	Symbol	Symbol explain
SAD	slave address	SAK	slave acknowledge
W	write	MAK	master acknowledge
R	read	NMASK	no master acknowledge
S	start	SUB	Sub-address(register address)
P	stop	DATA	Read or write data
SR	start		

4. Functionality

4.1. Terminology

4.1.1. Power mode

The da218 offers three work mode: sleep mode, forced mode and normal mode. These can be selected using the mode[1:0] bits in control register 0xF4:

Table 17. Mode settings

Mode[1:0]	Mode
00	Sleep mode
01 and 10	Forced mode
11	Normal mode

Sleep Mode :

The da2180 is powered on in sleep mode (Mode=00). All analog circuits are powered down and no conversion is taken in this mode. The current consumed is less than 0.1uA.

Force Mode:

In forced mode, a single measurement is performed according to selected measurement and filter options. When the measurement is finished, the sensor returns to sleep mode and the measurement results can be obtained from the data registers. For a next measurement, forced mode needs to be selected again.

Normal Mode:

Setting 'mode' = 11 gets into normal mode, the chip powers up and periodically performs once combined sensor conversion and a period of standby phase. The duration of the normal mode phase is configured by the 't_sb' bits from 0.5ms to 4s. The chip will not get back to sleep mode until manually setting 'mode' bits to 00b. Like the force mode, the combined sensor conversion in normal mode also combines with once temperature conversion, once pressure conversion and once humidity conversion while each conversion can be skipped by setting their OSR bits to 00b.

Table 18. T_SB settings

T_SB[1:0]	Tstandby[ms]
000	0.6
0001	73
010	140
011	285
100	550
101	1100
110	2200
111	4500

4.1.2. Current consumption

The current consumption depends on ODR and oversampling setting. The values given below are normalized to an ODR of 1 Hz. The actual ODR is defined either by the frequency at which the user sets forced measurements or by oversampling and tstandby settings in normal mode in the Table.

Table 19. Current consumption

Oversampling setting	Pressure oversampling	Temperature oversampling	I _{dd} [uA] @ 1Hz forced mode
001b	x1	x1	2.004
010b	x2	x2	2.500
011b	x4	x4	4.980
100b	x8	x8	8.452
101b&others	x16	x16	15.892

4.1.3. Measurement time

The following table explains the typical measurement time based on selected oversampling setting.

Table 20. Measurement time

Oversampling setting	Pressure oversampling	Temperature oversampling	Measurement times[ms]	Measurement
001b	x1	x1	4	250
010b	x2	x1	5	200
011b	x4	x1	7	143
100b	x8	x1	11	91
101b&others	x16	x2	20	50

4.1.4. Sensor data

The width of pressure and temperature data is 24bits given in three complement representation. The 24bits are split into an MSB part (one byte containing bits 23 to 16) , a CSB part (one byte containing bits 15 to 8)and an LSB lower part (one byte containing bits 7 to 0).

4.1.5. Factory calibration

The IC interface is factory calibrated at three temperatures and two pressures for sensitivity and accuracy.

The trimming values are stored inside the device by a non-volatile structure. Whenever the device is turned on, the trimming parameters are downloaded into the registers to be employed during normal operation. This allows the user to employ the device without requiring any further calibration.

5. Application hints

5.1. Connection diagram 4-wire SPI

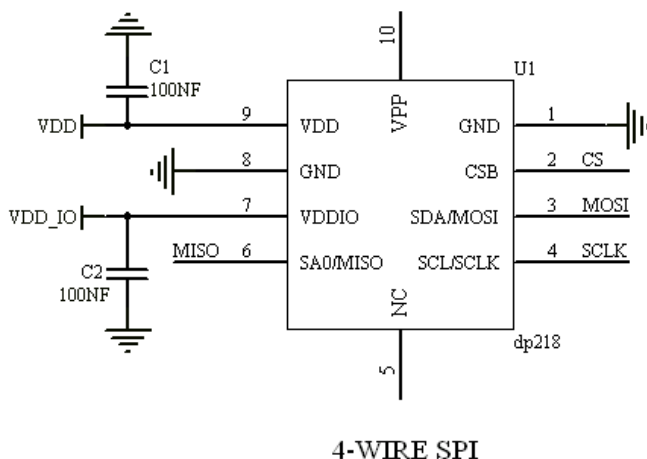

Figure 8. 4-wire SPI interface circuit

Notes:

- The recommended value for C1,C2 is 100NF.

5.2. Connection diagram 3-wire SPI

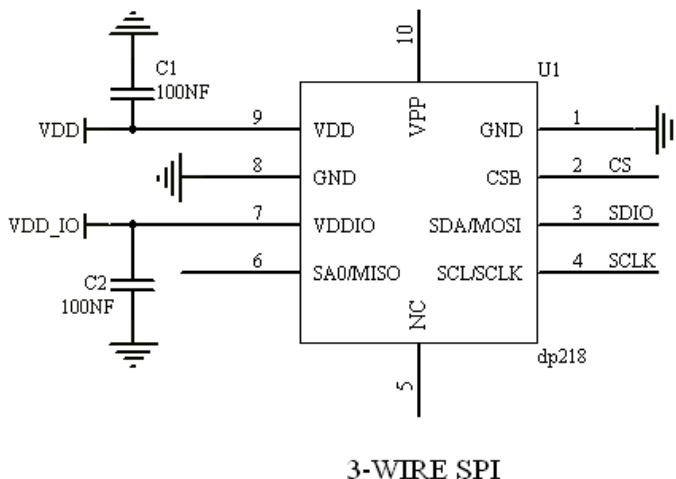

Figure 9. 3-wire SPI interface circuit

Notes:

- The recommended value for C1,C2 is 100NF.

5.3. Connection diagram IIC

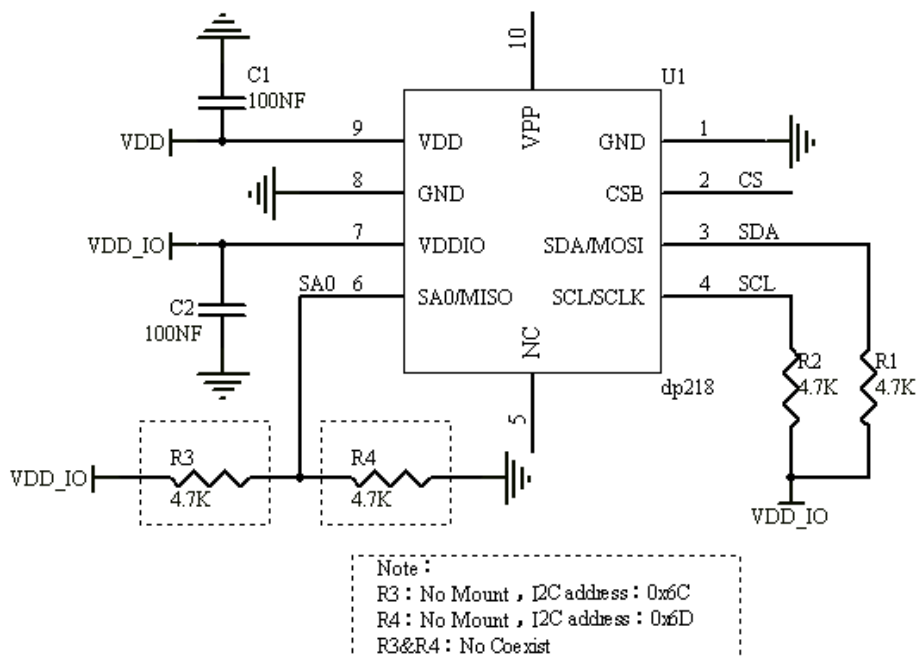

Figure 10. IIC interface circuit

Notes:

- The recommended value for C1,C2 is 100NF.
- The pull-up resistors are needed for IIC interface. The recommended value is 4.7K.

6. Register mapping

The table given below provides a listing of the 8 bit registers embedded in the device and the related addresses:

Table 21. Register address map

Name	Type	Register address	Default	Soft Reset
SPI_CTRL	RW	0x00	00H	NO
CHIP_ID	R	0xD0		NO
TEMP_LSB	R	0xFC	00H	YES
TEMP_CSB	R	0xFB	00H	YES
TEMP_MSB	R	0xFA	00H	YES
PRESS_LSB	R	0xF9	00H	YES
PRESS_CSB	R	0xF8	00H	YES
PRESS_MSB	R	0xF7	00H	YES
CONFIG	RW	0xF5	00H	YES
CTRL_MEAS	RW	0xF4	00H	YES
STATUS	R	0xF3	00H	YES
RESET	RW	0xE0	00H	YES
Calib0-Calib47	R	0xAF-0x80	individual	NO

7. Registers description

7.1. SPI_CTRL (00H)

Table 22. SPI_CTRL register

Default data: 0x00 Type: RW

SDO Active	LSB First	Unused	Unused	Unused	Unused	LSB First	SDO Active
------------	-----------	--------	--------	--------	--------	-----------	------------

Table 23. SPI_CTRL description

SDO Active	0:3-wire SPI 1:4-wire SPI
LSB First	0:MSB First 1:LSB First

7.2. CHIP_ID (D0H)

Table 24. CHIP_ID register

Default data: 0x Type: R

--	--	--	--	--	--	--	--

7.3. TEMP_LSB (FCH), TEMP_CSB(FBH), TEMP_MSB (FAH)

Temperature data, the value is expressed in three complement byte and are left justified.

Table 25. TEMP_LSB register

Default data: 0x00 Type: R

D[7]	D[6]	D[5]	D[4]	D[3]	D[2]	D[1]	D[0]
------	------	------	------	------	------	------	------

Table 26. TEMP_CSB register

Default data: 0x00 Type: R

D[15]	D[14]	D[13]	D[12]	D[11]	D[10]	D[9]	D[8]
-------	-------	-------	-------	-------	-------	------	------

Table 27. TEMP_MSB register

Default data: 0x00 Type: R

D[23]	D[22]	D[21]	D[20]	D[19]	D[18]	D[17]	D[16]
-------	-------	-------	-------	-------	-------	-------	-------

7.4. PRESS_LSB(F9H),PRESS_CS(BF8H),PRESS_MSB (F7H)

Press data, the value is expressed in three complement byte and are left justified.

Table 28. PRESS_LSB register

Default data: 0x00 Type: R

D[7]	D[6]	D[5]	D[4]	D[3]	D[2]	D[1]	D[0]
------	------	------	------	------	------	------	------

Table 29. PRESS_CS register

Default data: 0x00 Type: R

D[15]	D[14]	D[13]	D[12]	D[11]	D[10]	D[9]	D[8]
-------	-------	-------	-------	-------	-------	------	------

Table 30. PRESS_MSB register

Default data: 0x00 Type: R

D[23]	D[22]	D[21]	D[20]	D[19]	D[18]	D[17]	D[16]
-------	-------	-------	-------	-------	-------	-------	-------

7.5. CONFIG (F5H)

Table 31. CONFIG register

Default data: 0x00 Type: RW

T_SB[2]	T_SB[1]	T_SB [0]	FILTER[2]	FILTER [1]	FILTER [0]	Unused	Unused
---------	---------	----------	-----------	------------	------------	--------	--------

Table 32. CONFIG description

T_SB[2:0]	Control the sleep phase in sleep mode conversion 000:0.6ms 001: 73ms 010:140ms 011:285ms 100:550ms 101:1100ms 110:2200ms 111:4500ms
FILTER [2:0]	Control the bandwidth of the IIR filter 000:Filter Off 001: 0.223*ODR 010: 0.092*ODR 011: 0.042*ODR 100&Others: 0.021*ODR

7.6. CTRL_MEAS (F4H)

Table 33. CTRL_MEAS register

Default data: 0x00 Type: RW

OSR_T [2]	OSR_T [1]	OSR_T [0]	OSR_P[2]	OSR_P[1]	OSR_P[0]	MODE[1]	MODE[0]
-----------	-----------	-----------	----------	----------	----------	---------	---------

Table 34. CTRL_MEAS register description

OSR_T[2:0]	<p>Oversampling rate in temperature conversion</p> <p>000: Skipped, Output set to 0x000000</p> <p>001: OSRX1,</p> <p>010: OSRX2</p> <p>011: OSRX4</p> <p>100: OSRX8</p> <p>101& others: OSRX16</p>
OSR_P[2:0]	<p>Oversampling rate in pressure conversion</p> <p>000: Skipped, Output set to 0x000000</p> <p>001: OSRX1</p> <p>010: OSRX2</p> <p>011: OSRX4</p> <p>100: OSRX8</p> <p>101& others: OSRX16</p>
MODE[1:0]	<p>Mode Config</p> <p>00: Sleep Mode.</p> <p>01&10: Force Mode</p> <p>11: Normal Mode</p>

7.7. STATUS (F3H)

Table 35. STATUS register

Default data: 0x00 Type: R

Unused	Unused	Unused	Unused	ON_MEAS	Unused	Unused	MTP_UPD
--------	--------	--------	--------	---------	--------	--------	---------

Table 36. MOTION_FLAG register description

ON_MEAS	<p>0: Automatically set back to ‘0’ when the results have been transferred to the data registers</p> <p>1: Automatically set to ‘1’ whenever a conversion is running</p>
MTP_UPD	<p>0: Automatically set back to ‘0’ when the copying is done. The data are copied at power-on-reset and after soft reset</p> <p>1: Automatically set to ‘1’ when the MTP data are being copied to image registers</p>

7.8. RESET (E0H)

Table 37. RESET register

Default data: 0x00 Type: RW

RESET[7]	RESET[6]	RESET[5]	RESET[4]	RESET[3]	RESET[2]	RESET[1]	RESET[0]
----------	----------	----------	----------	----------	----------	----------	----------

Table 38. RESET register description

RESET [7:0]	RESET: Write 0xB6 to this register to reset all the registers, automatically come back to 0x00 after reset complete
-------------	---

8. SMT Guide

8.1. SMT Parameter Settings

8.1.1. Printing parameters

Table 39. Printing parameters

Machine Parameter	YGP
Squeegee pressure	65N
Squeegee speed	70mm/sec
Demolding distance	0.05~0.2mm
Separation speed	0.05~0.5mm/sec
Stencil cleaning methods	Automatic wet
Stencil cleaning frequency	1~5 per page
Paste increase in frequency	1/50 per page

8.1.2. Reflow oven Parameters

Table 40. Reflow oven Parameters

C1	H13	H11	H9	H7	H5	H3	H1	°C
170±5	280±5	275±5	245±5	210±5	200±5	180±5	160±5	
	H14	H12	H10	H8	H6	H4	H2	
	280±5	275±5	245±5	210±5	200±5	180±5	160±5	
Transfer Speed:	0.70±0.05m/min							

Table 41. Mangle Parameter

Management Item	SPEC
Peak Temp	250±5 °C
150~220°C	60~120S
220°C以上	30~60S
50-170°C average temperature gradient	0-2 °C/S
Oxygen concentration	<2000PPM

9. Package information

9.1. Outline dimensions

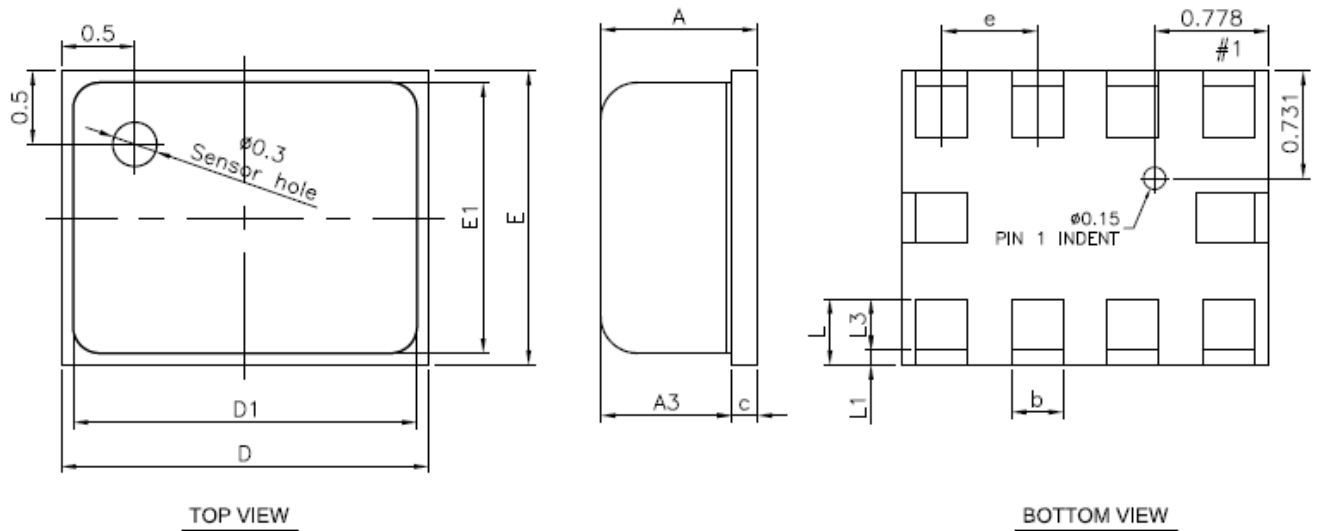

SYMBOLS	DIMENSIONS IN MILLIMETERS		
	MIN.	NOM.	MAX.
A	0.965	1.065	1.165
A3	---	0.855REF.	---
b	0.30	0.35	0.40
c	---	0.18 REF.	---
D	2.40	2.50	2.60
D1	2.24	2.34	2.44
E	1.90	2.00	2.10
E1	1.74	1.84	1.94
e	---	0.65	---
L	0.35	0.45	0.55
L1	0.05	0.10	0.15
L3	0.30	0.35	0.40

Notes:

Pick Area only extends to 0.25 mm of any edge or hole unless otherwise specified.

Dimensions are in millimeters unless otherwise specified.

Tolerance is ± 0.15 mm unless otherwise specified.

Figure 11. Mechanical data and package dimensions

9.2. Example land pattern

For the design of the landing patterns, we recommend the following dimensioning:

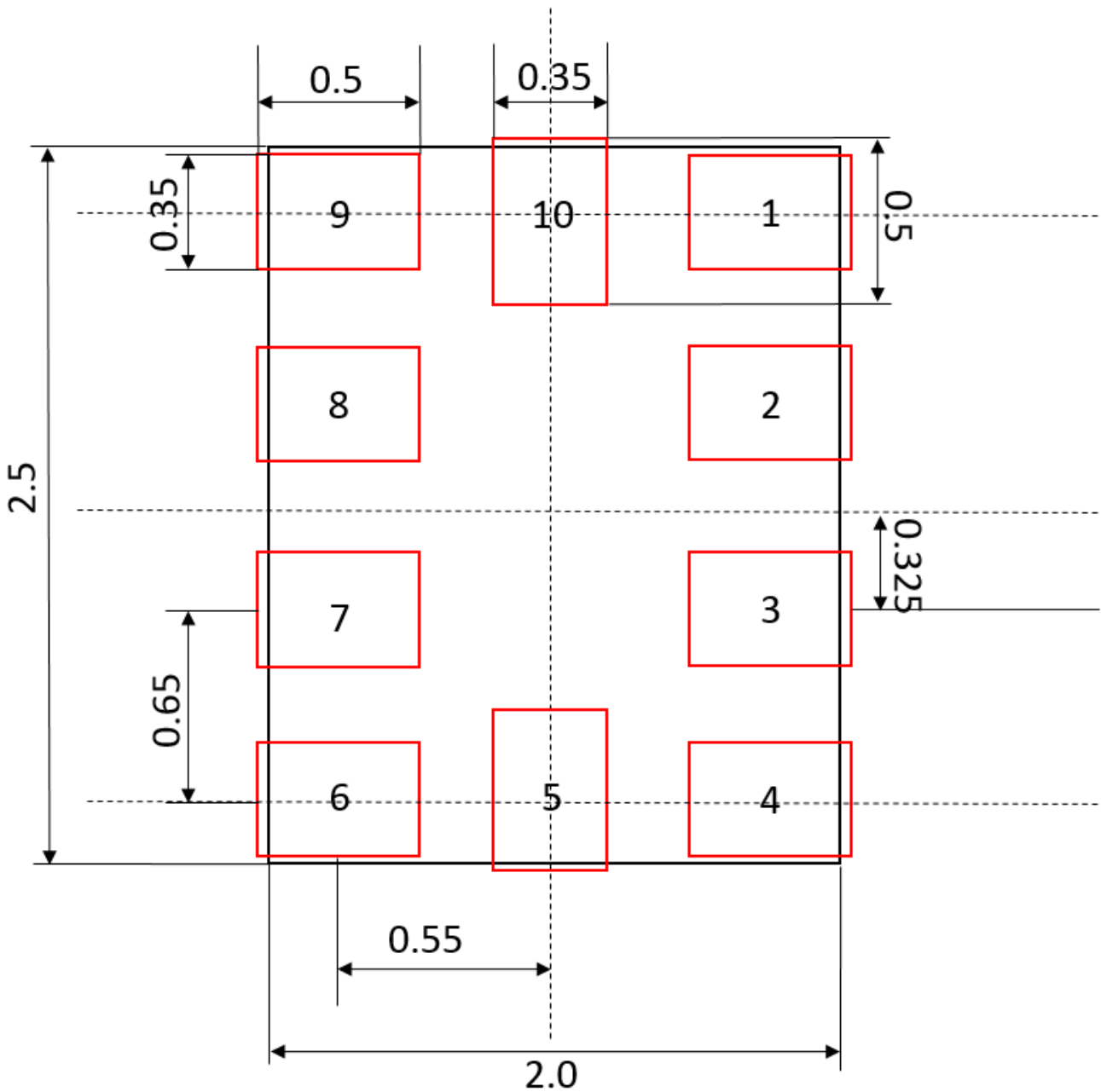

Notes:

Dimensions are in millimeters unless otherwise specified.

Figure 12. Example land pattern

9.3. Tape and reel specification

The da218 is shipped in a standard pizza box.

da218 quantity: 5000pcs per reel, please handle with care.

9.3.1. Tape specification

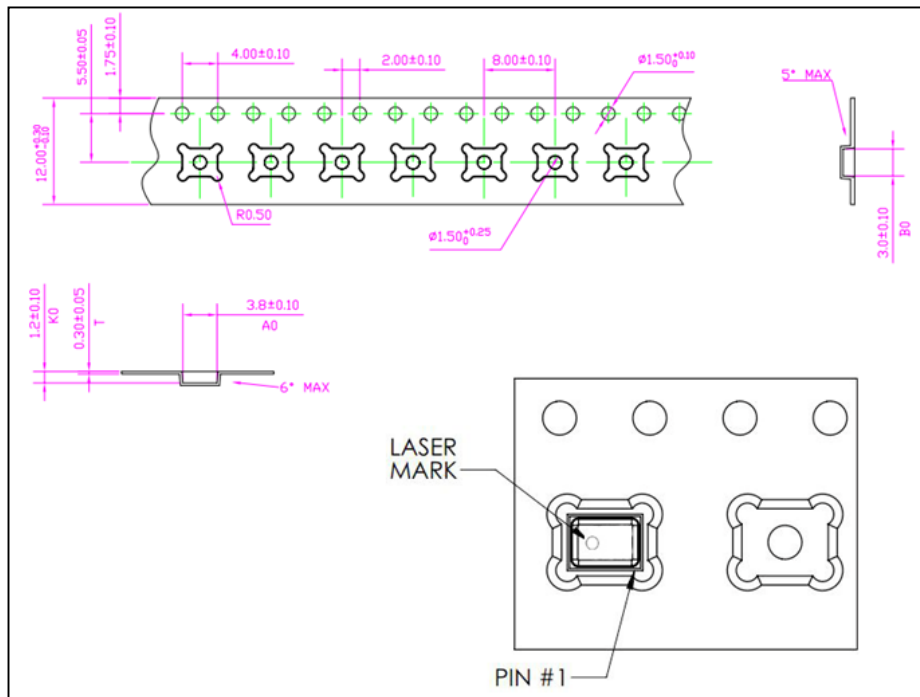

Figure 13. Tape and reel dimension in mm

Notes:

- 1、 Tape & reel per EIA-481.
- 2、 Dimensions are in millimeters unless otherwise specified.

Model Number	Reel Diameter	Quantity Per Reel
	13"	5000

10. Reliability specifications

Table 42. Accelerated Life Tests

Test	Condition	Qty/lot	Lot	Acc/Rej	Result
High Temperature Storage (HTS)	125°C, 1000hrs IEC 60068-2-2 Test Ba	25	3	0/1	PASS
Low Temperature Storage (LTS)	-40°C, 1000hrs IEC 60068-2-2 Test Aa	25	3	0/1	PASS
High Temperature Bias	125°C, 1000hrs, under bias IEC 60068-2-2 Test Ba	25	3	0/1	PASS
Low Temperature Bias	-40°C, 1000hrs, under bias IEC 60068-2-2 Test Aa	25	3	0/1	PASS
Temperature/Humidity Bias (THB)	+85°C/85% R.H. 1000hrs JEDEC JESD22-A101D	25	3	0/1	PASS

Table 43. Component Level Tests

Test	Condition	Qty/lot	Lot	Acc/Rej	Result
Preconditioning(MSL3)	24hrs HTSL (125C) ->192Hrs WHTSL (30C/60%RH) + 3x PbFree Reflow, 260C max JESD22-A113H	25	3	0/1	PASS
Thermal Shock	100 Cycles air-to-air thermal shock from -40°C to +125°C with 15 minute soaks, <30sec ramps IEC 60068-2-4	25	3	0/1	PASS
Drop Test	18 drops from 1.0m height onto concrete drop surface.	10	3	0/1	PASS
Mechanical Shock Test	10,000G/0.2ms, X/Y/Z 5 time/ direction MIL-STD-883 Method 2002.5	10	3	0/1	PASS
Vibration Test	4 cycles of 20-2000Hz sinusoidal Vibration with 20G peak acceleration lasting 12 minutes in X, Y and Z directions. Mil-Std-883E, Method 2007.2A	10	3	0/1	PASS
ESD Susceptibility	3 discharges of ±2,000V (HBM) direct contact to I/O pins. MIL 883E, Method 3015.7	6	1	0/1	PASS
	3 discharges of ±200V (MM) direct contact to I/O pins. JESD22-A115C	6	1	0/1	PASS
	3 discharges of ±8,000V (LID/GND) direct contact to lid while unit is grounded IEC 61000-4-2	6	1	0/1	PASS

11. Revision history

Table 44. Document revision history

Date	Revision	Changes
10-Oct.-2018	1.0	Initial release

单击下面可查看定价，库存，交付和生命周期等信息

[>>MiraMEMS\(明皊\)](#)