

(アクチュエータが開いた状態)
WHEN ACTUATOR IS OPENED

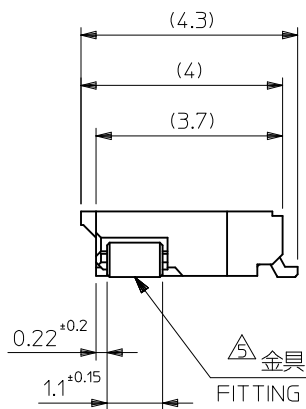

| | | | | | | | |
|------|------|------|------|------|------------------------------|---------------------|----------|
| 30.3 | 30.5 | 32.6 | 29.5 | 33.7 | 51296-6094 | 51296-6051 | 60 |
| 27.3 | 27.5 | 29.6 | 26.5 | 30.7 | 51296-5494 | 51296-5451 | 54 |
| 25.3 | 25.5 | 27.6 | 24.5 | 28.7 | 51296-5094 | 51296-5051 | 50 |
| 22.8 | 23.0 | 25.1 | 22.0 | 26.2 | 51296-4594 | 51296-4551 | 45 |
| 20.3 | 20.5 | 22.6 | 19.5 | 23.7 | 51296-4094 | 51296-4051 | 40 |
| 17.3 | 17.5 | 19.6 | 16.5 | 20.7 | 51296-3494 | 51296-3451 | 34 |
| 9.3 | 9.5 | 11.6 | 8.5 | 12.7 | 51296-1894 | 51296-1851 | 18 |
| 7.3 | 7.5 | 9.6 | 6.5 | 10.7 | 51296-1494 | 51296-1451 | 14 |
| 6.3 | 6.5 | 8.6 | 5.5 | 9.7 | 51296-1294 | 51296-1251 | 12 |
| 4.3 | 4.5 | 6.6 | 3.5 | 7.7 | 51296-0894 | 51296-0851 | 8 |
| E | D | C | B | A | EMBOSSED TAPE | 製品番号 (MATERIAL No.) | 極数 (Ckt) |
| | | | | | ORDER No. オーダー番号 (MODEL No.) | 51296-***51 | |

| | | | | | | | |
|--|---------------------------------------|--|----------------------------|---|--|------------------------------|------------------------|
| REVISED EC NO: J2011-0996 DRWN: KIMURAKAMI 2010/11/01 CHKD: APPR: KMORIKAWA 2011/02/15 | GENERAL TOLERANCES (UNLESS SPECIFIED) | | DIMENSION STYLE MM ONLY | | SCALE --- | DESIGN UNITS METRIC | THIRD ANGLE PROJECTION |
| | 10 UNDER | ±0.2 | DRAWN BY M.UMEDA | DATE 2005/02/22 | TITLE 0.5 FPC CONN ZIF E/O HSG ASSY (HGT=1.3) -LEAD FREE- | | |
| | 10 OVER 30 UNDER | ±0.25 | CHECKED BY KEN.SUZUKI | DATE 2005/02/22 | MOLEX INCORPORATED | | |
| | 30 OVER | ±0.3 | APPROVED BY N.UKITA | DATE 2005/02/22 | MATERIAL NO. SEE TABLE | DOCUMENT NO. SD-51296-011 | SHEET NO. 1 OF 2 |
| | ANGULAR ±1 ° | DRAFT WHERE APPLICABLE MUST REMAIN WITHIN DIMENSIONS | | THIS DRAWING CONTAINS INFORMATION THAT IS PROPRIETARY TO MOLEX INCORPORATED AND SHOULD NOT BE USED WITHOUT WRITTEN PERMISSION | | | |

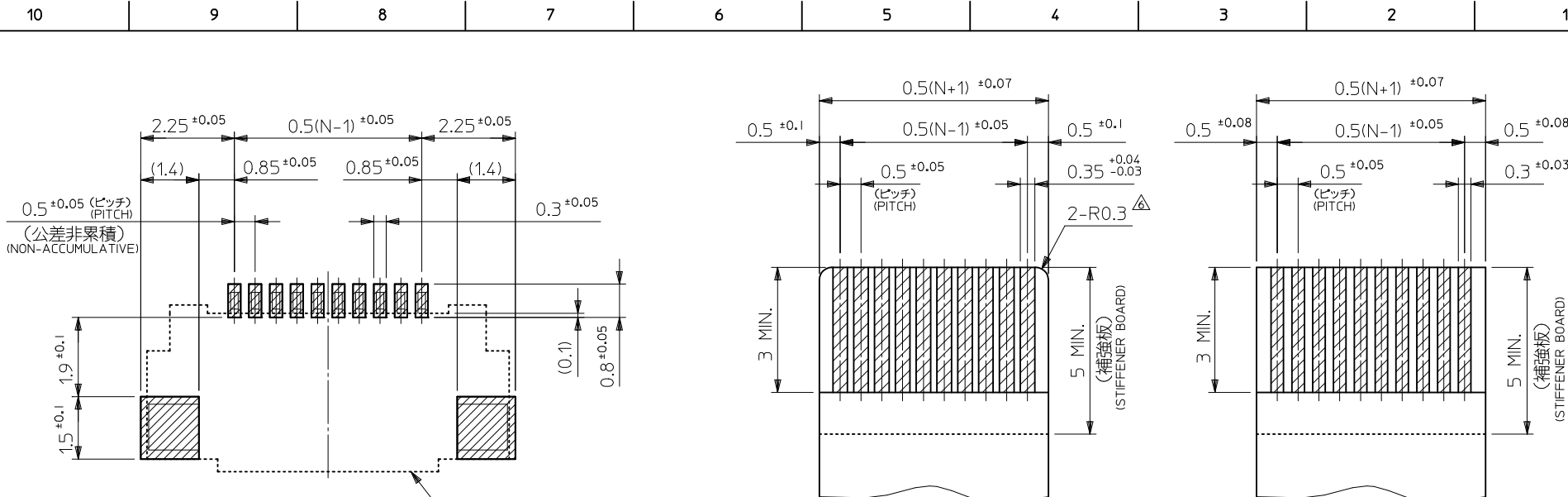

参考基板レイアウト
P.C. BOARD PATTERN
DIMENSION (REF.)
(マウント面)
(MOUNTING SIDE)

適合FPC推奨寸法
APPLICABLE FPC
RECOMMENDED DIMENSION
(仕上がり厚さ: 0.3 ±0.05)
(THICKNESS: 0.3 ±0.05)

適合FFC推奨寸法
APPLICABLE FFC
RECOMMENDED DIMENSION
(仕上がり厚さ: 0.3 ±0.05)
(THICKNESS: 0.3 ±0.05)

注記 NOTES

1. 使用材料 MATERIAL

ハウジング : 液晶ポリマー ガラス充填, UL94V-0 (ベージュ)
HOUSING : LIQUID CRYSTAL POLYMER GLASS FILLED, UL94V-0 (BEIGE)
アクチュエータ : ポリアミド 9T ガラス充填, UL94V-0 (黒)
ACTUATOR : POLYAMIDE 9T GLASS FILLED, UL94V-0 (BLACK)
ターミナル : リン青銅 (t=0.18)
TERMINAL : PHOSPOR BRONZE
金具 : リン青銅 (t=0.15)
FITTING NAIL : PHOSPOR BRONZE

3. エンボステープ梱包時は、アクチュエータが閉じた状態とする。
IN THE PACKAGE, ACTUATOR OF PART NO.51296-**51 SHOULD BE CLOSED.

- △ 偶数極に適用。
APPLY FOR EVEN CIRCUIT.
- △ /パターンはくり止め用金具
FITTING NAIL FOR PREVENTION OF PEELING OF PCB PATTERN.
- △ R0.3は、FPC導体部にかからないこと。
R0.3 MUST NOT BE OVERLAPPED TO PATTERN OF FPC.
- △ 極数によりハウジング形状が異なるので注意のこと。
THE HOUSING SHAPE IS DIFFERENT ACCORDING TO THE CIRCUIT.

FPC/FFCについて:

打抜き方向は導体側から補強板側を推奨いたします。
導体部については軟銅箔35マイクロメートルまたは50マイクロメートルを推奨致します。
ABOUT FPC/FFC
RECOMMENDED PUNCHER DIRECTION : FROM CONDUCTOR SIDE TO STIFFENER FILM SIDE.
RECOMMENDED CONDUCTOR SPEC :
THICKNESS OF SOFT COPPER FOIL : 35 MICROMETER OR 50 MICROMETER

FPCについて:

補強フィルム材質はポリイミドを推奨します。
接着剤は熱硬化接着剤を推奨します。
ABOUT FPC
RECOMMENDED MATERIAL :
STIFFENER FILM : POLYIMIDE
BONDING AGENT : THERMOSETTING BONDING AGENT

2. メッキ仕様 PLATING

ターミナル TERMINAL
コンタクト部: 金メッキ 0.1マイクロメートル以上
CONTACT AREA : GOLD 0.1 MICROMETER MINIMUM
テール部: 金メッキ 0.05マイクロメートル以上
TAIL AREA : GOLD 0.05 MICROMETER MINIMUM
下地メッキ: ニッケルメッキ 1.0マイクロメートル以上
UNDER PLATING : NICKEL 1.0 MICROMETER MINIMUM
金具 FITTING NAIL
銅メッキ 1.0マイクロメートル以上
TIN 1.0 MICROMETER MINIMUM
下地メッキ: ニッケルメッキ 1.0マイクロメートル以上
UNDER PLATING : NICKEL 1.0 MICROMETER MINIMUM

| | | | | | | |
|---|---------------------------------------|--|----------------------------|--|--|--|
| REVISED EC NO: J2011-0996 DRAWN: KOWURAKAMI 2010/11/01 CHKD: APPR: KMORIKAWA 2011/02/15 | GENERAL TOLERANCES (UNLESS SPECIFIED) | | DIMENSION STYLE MM ONLY | SCALE --- | 51296-**51 DESIGN UNITS METRIC | MODEL No. THIRD ANGLE PROJECTION |
| | 10 UNDER | ±0.2 | DRAWN BY M.UMEDA | DATE 2005/02/22 | TITLE 0.5 FPC CONN ZIF E/O HSG ASSY (HGT=1.3) -LEAD FREE- | |
| | 10 OVER 30 UNDER | ±0.25 | CHECKED BY KEN.SUZUKI | DATE 2005/02/22 | MOLEX INCORPORATED | |
| | 30 OVER | ±0.3 | APPROVED BY N.UKITA | DATE 2005/02/22 | MATERIAL NO. SEE TABLE | DOCUMENT NO. SD-51296-011 |
| ANGULAR ±1 ° | | DRAFT WHERE APPLICABLE MUST REMAIN WITHIN DIMENSIONS | | THIS DRAWING CONTAINS INFORMATION THAT IS PROPRIETARY TO MOLEX INCORPORATED AND SHOULD NOT BE USED WITHOUT WRITTEN PERMISSION | | |

NOTES

- 製品詳細寸法は製品単体図面を参照して下さい。
FOR DETAIL OF CONNECTOR DIMENSIONS, PLEASE SEE THE DRAWING OF CONNECTOR ITSELF (NOT PACKAGED).
- 梱包数量：3000個/リール
NUMBER OF CONNECTORS : 3000PCS/REEL
- リードテープ長さ LEAD TAPE LENGTH

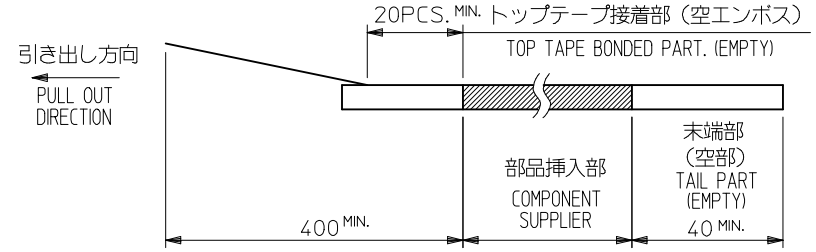

- トップテープの剥離強度：0.1N～1.3N(10gf～130gf)
(剥離方向は下図参照)
尚、本規格値は出荷時に適用。(但し、輸送時に剥離が発生しないこと。)
PEELING OFF FORCE OF TOP TAPE : 0.1N～1.3N(10gf～130gf)
(PEELING DIRECTION AS SHOWN IN FOLLOWING FIG.)
THIS REQUIREMENT SHOULD BE APPLIED AT SHIPMENT.
PEEL OFF SHOULD NOT BE ALLOWED , DURING TRANSPORTATION.

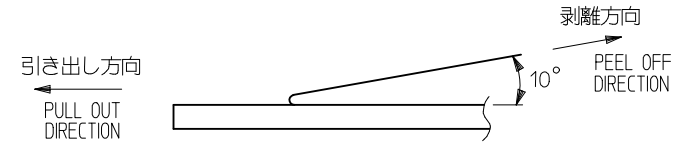

- 材料(MATERIAL)
キャリアテープ (CARRIER TAPE) :ポリプロピレン (POLYPROPYLENE)
トップテープ (TOPTAPE) : PET, PE, PEF
リール (REEL): ポリスチレン (PS) <リサイクル材を含む>
POLYSTYRENE (PS) <RECYCLE MATERIAL CONTAINED>

引き出し方向
PULL OUT DIRECTION

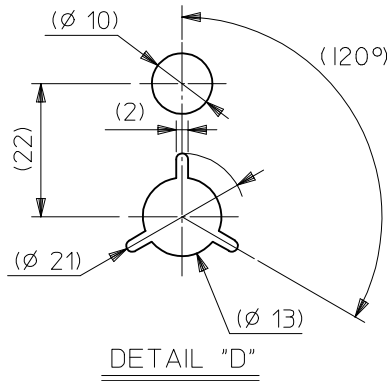
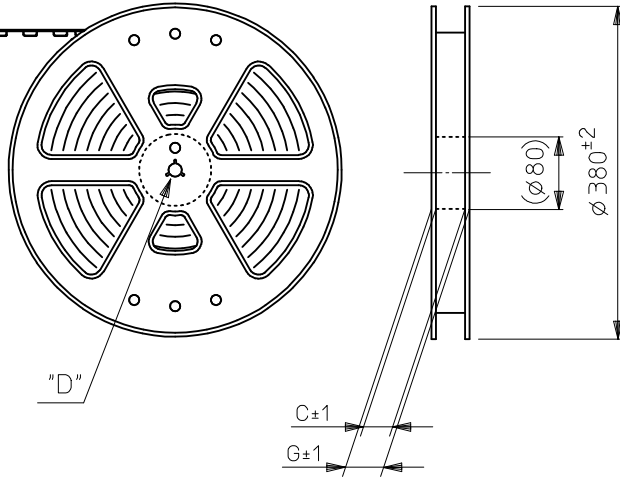

| | | | | | | | |
|--|--|--|---|--|---|-------------|---------------------|
| REVISED EC NO.: J2009-0892 DRWN: TAKAHASHI 103 2008/10/14 CHKD: THARUYAMA 2008/10/14 APPR: NUKITA 2008/10/14 | GENERAL TOLERANCES (UNLESS SPECIFIED) | | DIMENSION STYLE MM ONLY | | SCALE --- | 51296-**-94 | MODEL NO. |
| | 10 UNDER ±0.2 | | DRAWN BY DATE M. UMEDA 2005/02/23 | | THIRD ANGLE PROJECTION | | |
| | 10 OVER 30 UNDER ±0.25 | | CHECKED BY DATE KEN. SUZUKI 2005/02/23 | | 0.5 FPC CONN EASY ON HGT=1.3MM EMBSTP PKG | | |
| | 30 OVER ±0.3 | | APPROVED BY DATE N. UKITA 2005/02/23 | | MOLEX INCORPORATED | | |
| DESCRIPTION | ANGULAR ±1 ° | | MATERIAL NO. SEE CHART | | DOCUMENT NO. SD-51296-012 | | SHEET NO. 1 OF 3 |
| REVISION | DRAFT WHERE APPLICABLE MUST REMAIN WITHIN DIMENSIONS | | SIZE A3 | | THIS DRAWING CONTAINS INFORMATION THAT IS PROPRIETARY TO MOLEX INCORPORATED AND SHOULD NOT BE USED WITHOUT WRITTEN PERMISSION | | |

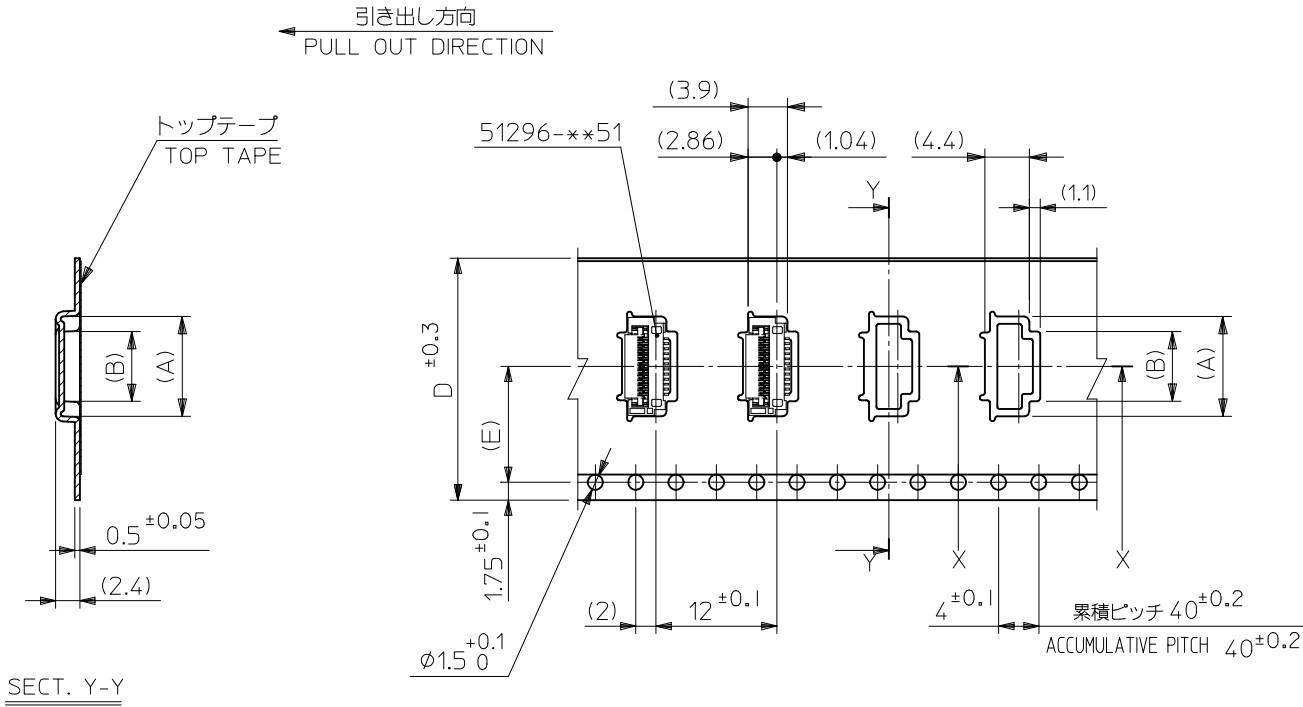

| | | | | | | |
|------|----|------|------|------|---------------------|-----------|
| 11.5 | 24 | 25.4 | 9.89 | 12.9 | 51296-1894 | 18 |
| | | | 7.89 | 10.9 | 51296-1494 | 14 |
| | | | 6.89 | 9.9 | 51296-1294 | 12 |
| 7.5 | 16 | 17.4 | 4.89 | 7.9 | 51296-0894 | 8 |
| (E) | D | C | (B) | (A) | 製品番号 MATERIAL No | 極数 Ckt |

| | | | | | | | |
|---|---------------------------------------|--|----------------------------|---------------------------|---|------------------------|--------------------------|
| REVISED EC NO: J2009-0892 DRWN: TAKAHASHI 103 2008/10/14 CHKD: THARUYAMA 2008/10/14 APPR: NUKITA 2008/10/14 | GENERAL TOLERANCES (UNLESS SPECIFIED) | | DIMENSION STYLE MM ONLY | | SCALE --- | DESIGN UNITS METRIC | MODEL NO. 51296-**-94 |
| | 10 UNDER | ±0.2 | DRAWN BY M.UMEDA | DATE 2005/02/23 | TITLE 0.5 FPC CONN EASY ON HGT=1.3MM EMBSTP PKG | | |
| | 10 OVER 30 UNDER | ±0.25 | CHECKED BY KEN.SUZUKI | DATE 2005/02/23 | THIRD ANGLE PROJECTION | | |
| | 30 OVER | ±0.3 | APPROVED BY N. NUKITA | DATE 2005/02/23 | MOLEX INCORPORATED | | |
| | ANGULAR ±1 ° | DRAFT WHERE APPLICABLE MUST REMAIN WITHIN DIMENSIONS | | MATERIAL NO. SEE CHART | DOCUMENT NO. SD-51296-012 | SHEET NO. 2 OF 3 | |
| | | THIS DRAWING CONTAINS INFORMATION THAT IS PROPRIETARY TO MOLEX INCORPORATED AND SHOULD NOT BE USED WITHOUT WRITTEN PERMISSION | | | | | |

CONFIDENTIAL

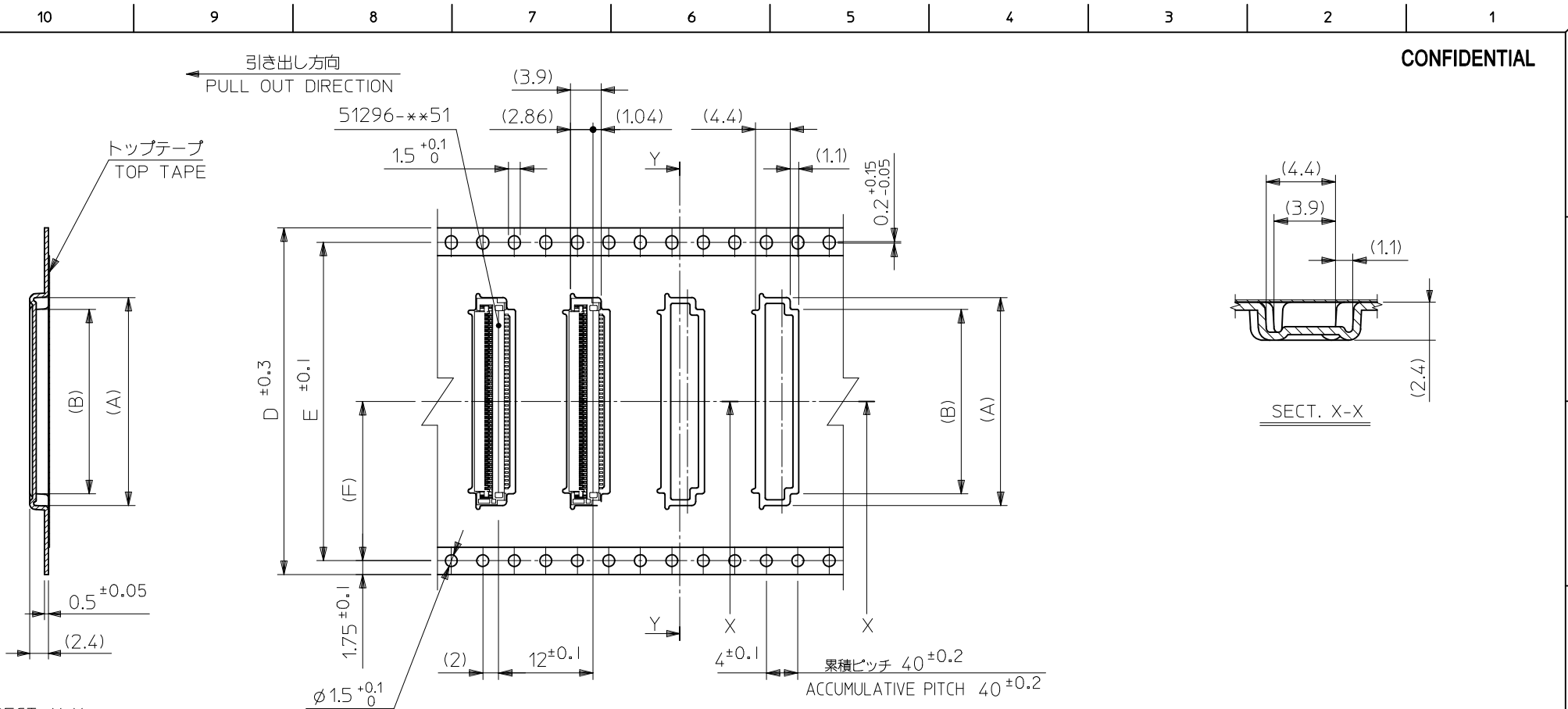

SECT. Y-Y

SECT. X-X

| | | | | | | | | |
|------|------|------|----|------|-------|------|---------------------|-----------|
| 61.4 | 26.2 | 52.4 | 56 | 57.4 | 30.89 | 33.9 | 51296-6094 | 60 |
| | | | | | 27.89 | 30.9 | 51296-5494 | 54 |
| 49.4 | 20.2 | 40.4 | 44 | 45.4 | 25.89 | 28.9 | 51296-5094 | 50 |
| | | | | | 23.39 | 26.4 | 51296-4594 | 45 |
| | | | | | 20.89 | 23.9 | 51296-4094 | 40 |
| 37.4 | 14.2 | 28.4 | 32 | 33.4 | 17.89 | 20.9 | 51296-3494 | 34 |
| G | (F) | E | D | C | (B) | (A) | 製品番号 MATERIAL No | 極数 Ckt |

| | | | | | | | | | | |
|--|--|--|-----------------------------------|------------|---|--|--|--|------------------------------|--|
| REVISED EC NO: J2009-0892 DRWN: TAKAHASHI 03/2008/10/14 CHK'D: THARUYAMA 2008/10/14 APPR: NUKITA 2008/10/14 | GENERAL TOLERANCES (UNLESS SPECIFIED) | | DIMENSION STYLE MM ONLY | | SCALE --- DESIGN UNITS METRIC | | MODEL NO. 51296-**94 | | THIRD ANGLE PROJECTION | |
| | 10 UNDER ±0.2 | | DRAWN BY M. UMEDA | | DATE 2005/02/23 | | TITLE 0.5 FPC CONN EASY ON HGT=1.3MM EMBSTP PKG | | | |
| | 10 OVER 30 UNDER ±0.25 | | CHECKED BY KEN. SUZUKI | | DATE 2005/02/23 | | MOLEX INCORPORATED | | | |
| | 30 OVER ±0.3 | | APPROVED BY N. UKITA | | DATE 2005/02/23 | | MATERIAL NO. SEE CHART | | DOCUMENT NO. SD-51296-012 | |
| ANGULAR ±1 ° | | DRAFT WHERE APPLICABLE MUST REMAIN WITHIN DIMENSIONS | | SIZE A3 | | THIS DRAWING CONTAINS INFORMATION THAT IS PROPRIETARY TO MOLEX INCORPORATED AND SHOULD NOT BE USED WITHOUT WRITTEN PERMISSION | | | | |

单击下面可查看定价，库存，交付和生命周期等信息

[>>MOLEX](#)