

| GENERAL TOLERANCE | | | | | | | | | | USED ON |
|-------------------|--------|--------|--------|---------|---------|---------|----------|-------|--------|---------|
| 10 MAX | 30 MAX | 50 MAX | 70 MAX | 100 MAX | 120 MAX | 250 MAX | 250 OVER | ANGLE | ECCENT | |
| ±0.15 | ±0.20 | ±0.30 | ±0.40 | ±0.50 | ±0.75 | ±0.90 | ±1.4 | ±0.5° | 0.1 | |

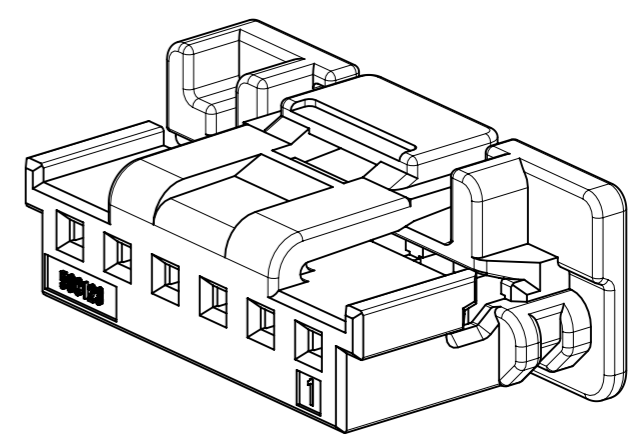

ISO VIEW

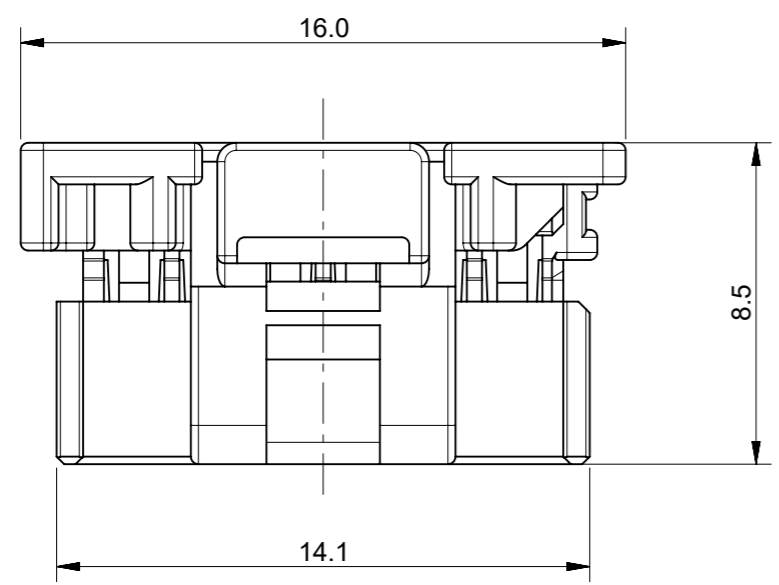
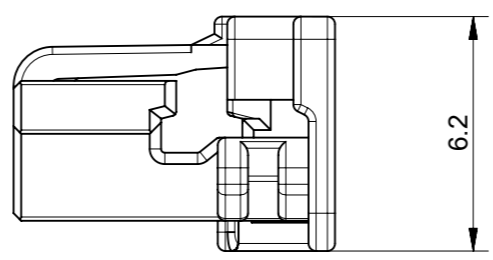
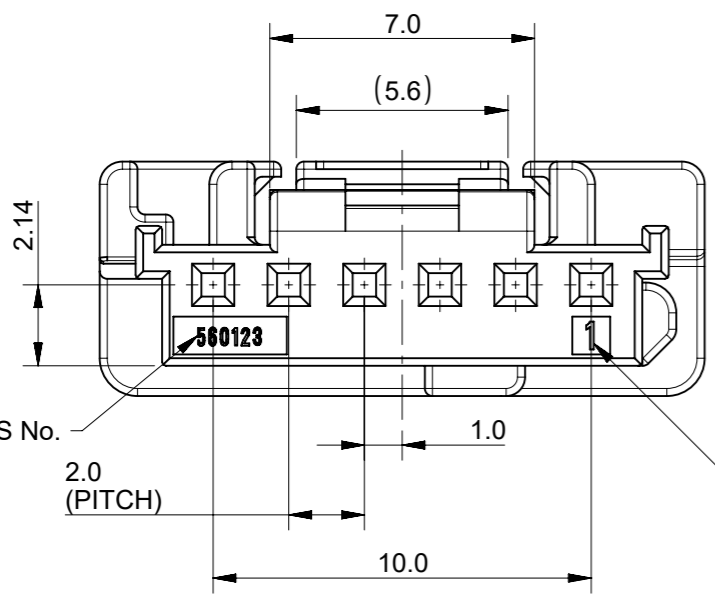

CIRCUIT No.

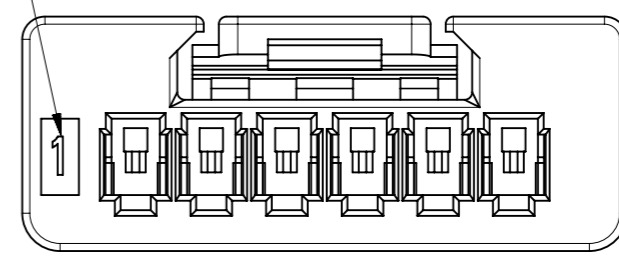

SERIES No. 2.0 (PITCH) 10.0 1.0 CIRCUIT No.

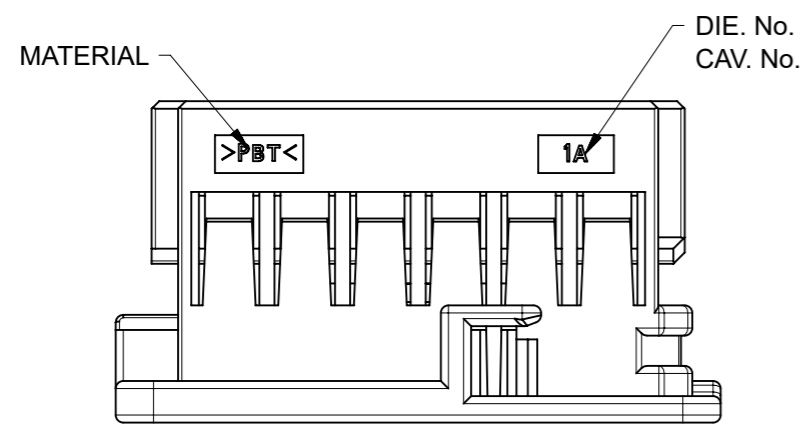

- NOTES:
1. MATERIALS : POLYESTER (PBT), GLASS UNFILLED, UL 94V-0
 2. MATE WITH : 502352, 560020 SERIES
 3. APPLICABLE TERMINAL : 560124 SERIES
 4. APPLICABLE ISL : 560125 SERIES
 5. GENERAL TOLERANCE : SEE TABLE
 6. EVL AND RoHS COMPLIANT
 7. PRODUCT SPECIFICATION : PS-560123-00*
 8. PACKING SPECIFICATION : PK-560123-001

MATERIAL NUMBER

| ORDER NO. | MATERIAL NO. | COLOR |
|-------------|--------------|-------|
| 560123-0600 | 5601230600 | WHITE |
| 560123-0601 | 5601230601 | BLACK |
| 560123-0602 | 5601230602 | RED |
| 560123-0604 | 5601230604 | BLUE |

| FUNCTIONAL SYMBOLS | THIS DRAWING CONTAINS INFORMATION THAT IS PROPRIETARY TO MOLEX ELECTRONIC TECHNOLOGIES, LLC AND SHOULD NOT BE USED WITHOUT WRITTEN PERMISSION | CURRENT REV DESC: | | | | | | | | | | | | | | | | | | | | | | | | | | | | | | | | | | | | | | | | | | | | | | | | | | | | | | | | | | | | | | | | | | | | | | | |
|--|---|--------------------|-------------------|------------|-----------------|--|----------------|----------|----------------|----|-----|----------------|---------------------------------------|--|----------------|-----------------|--|--------------------|----------|---|---------------|------------|----------|---|-------------|------------|----------|---|---------------|------------|---------|---|--------------|--|----------|---|-------------------|--|--|--|--|--------------|------------|-----------------|--|----------|----------|----------|------------------------|--|--|-------------|------------|---------------|--|-----|-----|----|---------|--|--|--------|--|-----------------|--|----------|--|--------------|---------|--|--|--------|--|
| | <table border="1"> <tr> <th>FUNCTIONAL SYMBOLS</th> <th>DIMENSION UNITS</th> <th>SCALE</th> </tr> <tr> <td>$\nabla_A = 0$</td> <td>mm</td> <td>5:1</td> </tr> <tr> <td>$\nabla_E = 0$</td> <td colspan="2">GENERAL TOLERANCES (UNLESS SPECIFIED)</td> </tr> <tr> <td>$\nabla_V = 0$</td> <td colspan="2">ANGULAR TOL ± °</td> </tr> <tr> <td rowspan="5">DIVISIONAL SYMBOLS</td> <td>4 PLACES</td> <td>±</td> <td>EC NO: 668822</td> <td>2021/07/01</td> </tr> <tr> <td>3 PLACES</td> <td>±</td> <td>DRWN: SAKIM</td> <td>2021/07/05</td> </tr> <tr> <td>2 PLACES</td> <td>±</td> <td>CHK'D: HIJIMA</td> <td>2021/07/05</td> </tr> <tr> <td>1 PLACE</td> <td>±</td> <td>APPR: HIJIMA</td> <td></td> </tr> <tr> <td>0 PLACES</td> <td>±</td> <td>INITIAL REVISION:</td> <td></td> </tr> <tr> <td colspan="3">DRAFT WHERE APPLICABLE MUST REMAIN WITHIN DIMENSIONS</td> <td>DRWN: YIBAEK</td> <td>2014/07/08</td> <td colspan="2">DOCUMENT NUMBER</td> <td>DOC TYPE</td> <td>DOC PART</td> <td>REVISION</td> </tr> <tr> <td colspan="3">THIRD ANGLE PROJECTION</td> <td>APPR: SRTAK</td> <td>2014/08/26</td> <td colspan="2">SD-560123-004</td> <td>PSD</td> <td>001</td> <td>C2</td> </tr> <tr> <td colspan="3">DRAWING</td> <td colspan="2">SERIES</td> <td colspan="2">MATERIAL NUMBER</td> <td colspan="2">CUSTOMER</td> <td>SHEET NUMBER</td> </tr> <tr> <td colspan="3">A3-SIZE</td> <td colspan="2">560123</td> <td colspan="2">SEE TABLE</td> <td colspan="2">GENERAL MARKET</td> <td>1 OF 1</td> </tr> </table> | FUNCTIONAL SYMBOLS | DIMENSION UNITS | | | | | SCALE | $\nabla_A = 0$ | mm | 5:1 | $\nabla_E = 0$ | GENERAL TOLERANCES (UNLESS SPECIFIED) | | $\nabla_V = 0$ | ANGULAR TOL ± ° | | DIVISIONAL SYMBOLS | 4 PLACES | ± | EC NO: 668822 | 2021/07/01 | 3 PLACES | ± | DRWN: SAKIM | 2021/07/05 | 2 PLACES | ± | CHK'D: HIJIMA | 2021/07/05 | 1 PLACE | ± | APPR: HIJIMA | | 0 PLACES | ± | INITIAL REVISION: | | DRAFT WHERE APPLICABLE MUST REMAIN WITHIN DIMENSIONS | | | DRWN: YIBAEK | 2014/07/08 | DOCUMENT NUMBER | | DOC TYPE | DOC PART | REVISION | THIRD ANGLE PROJECTION | | | APPR: SRTAK | 2014/08/26 | SD-560123-004 | | PSD | 001 | C2 | DRAWING | | | SERIES | | MATERIAL NUMBER | | CUSTOMER | | SHEET NUMBER | A3-SIZE | | | 560123 | |
| FUNCTIONAL SYMBOLS | DIMENSION UNITS | SCALE | | | | | | | | | | | | | | | | | | | | | | | | | | | | | | | | | | | | | | | | | | | | | | | | | | | | | | | | | | | | | | | | | | | | | | | |
| $\nabla_A = 0$ | mm | 5:1 | | | | | | | | | | | | | | | | | | | | | | | | | | | | | | | | | | | | | | | | | | | | | | | | | | | | | | | | | | | | | | | | | | | | | | | |
| $\nabla_E = 0$ | GENERAL TOLERANCES (UNLESS SPECIFIED) | | | | | | | | | | | | | | | | | | | | | | | | | | | | | | | | | | | | | | | | | | | | | | | | | | | | | | | | | | | | | | | | | | | | | | | | |
| $\nabla_V = 0$ | ANGULAR TOL ± ° | | | | | | | | | | | | | | | | | | | | | | | | | | | | | | | | | | | | | | | | | | | | | | | | | | | | | | | | | | | | | | | | | | | | | | | | |
| DIVISIONAL SYMBOLS | 4 PLACES | ± | EC NO: 668822 | 2021/07/01 | | | | | | | | | | | | | | | | | | | | | | | | | | | | | | | | | | | | | | | | | | | | | | | | | | | | | | | | | | | | | | | | | | | | | |
| | 3 PLACES | ± | DRWN: SAKIM | 2021/07/05 | | | | | | | | | | | | | | | | | | | | | | | | | | | | | | | | | | | | | | | | | | | | | | | | | | | | | | | | | | | | | | | | | | | | | |
| | 2 PLACES | ± | CHK'D: HIJIMA | 2021/07/05 | | | | | | | | | | | | | | | | | | | | | | | | | | | | | | | | | | | | | | | | | | | | | | | | | | | | | | | | | | | | | | | | | | | | | |
| | 1 PLACE | ± | APPR: HIJIMA | | | | | | | | | | | | | | | | | | | | | | | | | | | | | | | | | | | | | | | | | | | | | | | | | | | | | | | | | | | | | | | | | | | | | | |
| | 0 PLACES | ± | INITIAL REVISION: | | | | | | | | | | | | | | | | | | | | | | | | | | | | | | | | | | | | | | | | | | | | | | | | | | | | | | | | | | | | | | | | | | | | | | |
| DRAFT WHERE APPLICABLE MUST REMAIN WITHIN DIMENSIONS | | | DRWN: YIBAEK | 2014/07/08 | DOCUMENT NUMBER | | DOC TYPE | DOC PART | REVISION | | | | | | | | | | | | | | | | | | | | | | | | | | | | | | | | | | | | | | | | | | | | | | | | | | | | | | | | | | | | | | | | |
| THIRD ANGLE PROJECTION | | | APPR: SRTAK | 2014/08/26 | SD-560123-004 | | PSD | 001 | C2 | | | | | | | | | | | | | | | | | | | | | | | | | | | | | | | | | | | | | | | | | | | | | | | | | | | | | | | | | | | | | | | | |
| DRAWING | | | SERIES | | MATERIAL NUMBER | | CUSTOMER | | SHEET NUMBER | | | | | | | | | | | | | | | | | | | | | | | | | | | | | | | | | | | | | | | | | | | | | | | | | | | | | | | | | | | | | | | | |
| A3-SIZE | | | 560123 | | SEE TABLE | | GENERAL MARKET | | 1 OF 1 | | | | | | | | | | | | | | | | | | | | | | | | | | | | | | | | | | | | | | | | | | | | | | | | | | | | | | | | | | | | | | | | |

单击下面可查看定价，库存，交付和生命周期等信息

[>>MOLEX](#)