

NOTE : (2) POLARIZATION PEGS ARE SHOWN, HOWEVER, ASSEMBLIES MAY BE MANUFACTURED WITH (1) PEG ONLY.

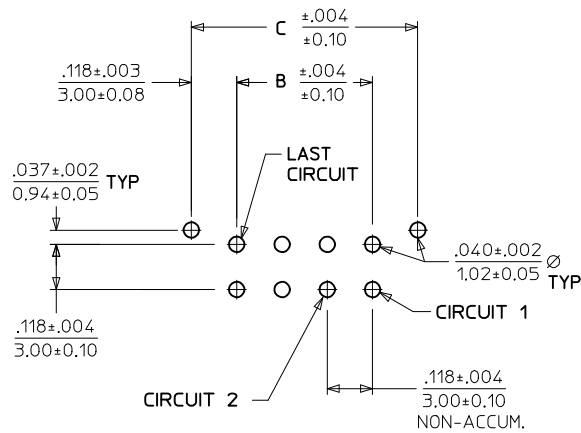

PCB LAYOUT: COMPONENT SIDE
RECOMMEND PCB THICKNESS: .062/1.57

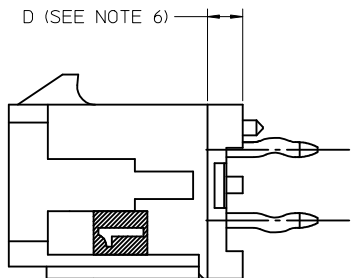
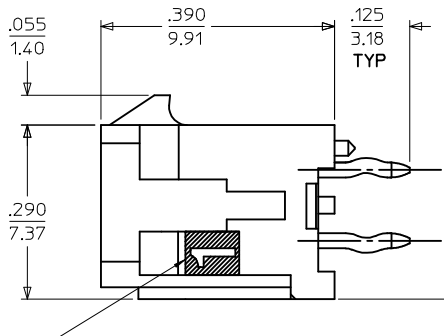
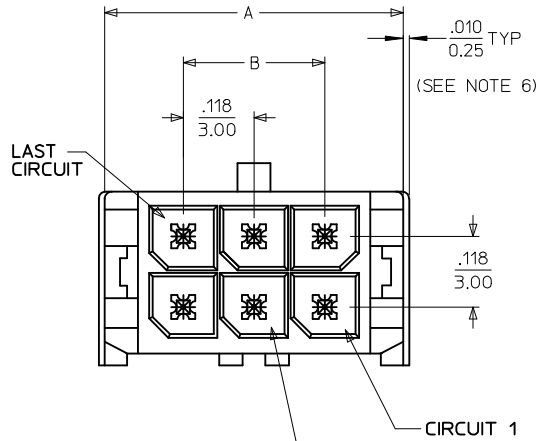

- NOTES:**
- HOUSING MATERIAL: GLASS FILLED LIQUID CRYSTAL POLYMER, UL94V-0, COLOR: BLACK
TERMINAL MATERIAL: BRASS ALLOY
 - FINISH: A = .000060/(0.00152) MIN. REFLOWED MATTE TIN OVER .000050/(0.00127) MIN. NICKEL PLATE. (FINISH IS BRIGHT IN APPEARANCE. THICKNESS AS APPLIED PRIOR TO REFLOW)
B = .000015/(0.00038) MIN. SELECT GOLD IN CONTACT AREA, .000100/(0.00254) MIN. SELECT MATTE TIN ON SOLDER TAILS, BOTH OVER .000050/(0.00127) MIN. NICKEL PLATE.
C = .000030/(0.00076) MIN. SELECT GOLD IN CONTACT AREA, .000100/(0.00254) MIN. SELECT MATTE TIN ON SOLDER TAILS, BOTH OVER .000050/(0.00127) MIN. NICKEL PLATE.
D = .000100/(0.00254) MIN. MATTE TIN OVER .000050/(0.00127) MIN. NICKEL PLATE.
 - PRODUCT SPECIFICATION: PS-43045
 - TRAY PACKAGED: SEE MOLEX DRAWING PK-70873-0314
 - MATES WITH MICRO FIT (3.0) RECEPTACLE SERIES 43025
 - CIRCUIT SIZES 2-6: "D" IS 0.265/6.74 FOR .010/0.25 STEP. CIRCUIT SIZES 8-24: "D" IS 0.063/1.60 FOR .010/0.25 STEP.
 - THIS PART CONFORMS TO CLASS B REQUIREMENTS OF COSMETIC SPECIFICATION PS-45499-002.

	FINISH A	FINISH B	FINISH C	FINISH D
02	43045-0212	43045-0213	43045-0214	43045-0311
04	43045-0412	43045-0413	43045-0414	43045-0511
06	43045-0612	43045-0613	43045-0614	43045-0711
08	43045-0812	43045-0813	43045-0814	43045-0911
10	43045-1012	43045-1013	43045-1014	43045-1111
12	43045-1212	43045-1213	43045-1214	43045-1311
14	43045-1412	43045-1413	43045-1414	43045-1511
16	43045-1612	43045-1613	43045-1614	43045-1711
18	43045-1812	43045-1813	43045-1814	43045-1911
20	43045-2012	43045-2013	43045-2014	43045-2111
22	43045-2212	43045-2213	43045-2214	43045-2311
24	43045-2412	43045-2413	43045-2414	43045-2511

FINISH A & D EC NO: UCP2016-4586 DRAWN: JDOX 2015/12/10 CHKD: SSOUSEK 2015/12/10 APPR: FSM/TH 2016/08/23	QUALITY SYMBOLS ∇=0 ∇=0 ∇=0	GENERAL TOLERANCES (UNLESS SPECIFIED) <table border="1"> <tr> <th></th> <th>mm</th> <th>INCH</th> </tr> <tr> <td>4 PLACES</td> <td>± .010</td> <td>± .0004</td> </tr> <tr> <td>3 PLACES</td> <td>± .010</td> <td>± .0004</td> </tr> <tr> <td>2 PLACES</td> <td>± 0.25</td> <td>± .010</td> </tr> <tr> <td>1 PLACE</td> <td>± 0.36</td> <td>± .014</td> </tr> <tr> <td>0 PLACE</td> <td>± .---</td> <td>± .---</td> </tr> </table>		mm	INCH	4 PLACES	± .010	± .0004	3 PLACES	± .010	± .0004	2 PLACES	± 0.25	± .010	1 PLACE	± 0.36	± .014	0 PLACE	± .---	± .---	DIMENSION STYLE IN/MM DRAWN BY: SAMIEC DATE: 2000/03/15 CHECKED BY: SSOUSEK DATE: 2016/06/01 APPROVED BY: FSM/TH DATE: 2016/08/23	SCALE: --- DESIGN UNITS: METRIC THIRD ANGLE PROJECTION
		mm	INCH																			
	4 PLACES	± .010	± .0004																			
	3 PLACES	± .010	± .0004																			
2 PLACES	± 0.25	± .010																				
1 PLACE	± 0.36	± .014																				
0 PLACE	± .---	± .---																				
DRAFT WHERE APPLICABLE MUST REMAIN WITHIN DIMENSIONS		MATERIAL NO. SEE CHART	TITLE MICRO FIT (3.0) DUAL ROW VERTICAL THRU HOLE HEADER ASS'Y molex																			
		DOCUMENT NO. SD-43045-005	SHEET NO. 1 OF 1																			
THIS DRAWING CONTAINS INFORMATION THAT IS PROPRIETARY TO MOLEX INCORPORATED AND SHOULD NOT BE USED WITHOUT WRITTEN PERMISSION																						

单击下面可查看定价，库存，交付和生命周期等信息

[>>MOLEX](#)