

PART NO.	ENG. NO.	MAT'L.	PLATE	WIRE GAGE	DIM. "B"	DIM. "C"	DIM. "D"	DIM. "E"	DIM. "F"	DIM. "G"
39-00-0207	5556-SP	A BRASS	TIN	18-24 GA.	.142±.012 (3.60±0.30)	.177±.016 (4.50±0.40)	.035 ±.016 (0.90)±0.40	.075±.012 (1.90±0.30)	.091±.016 (2.30±0.40)	.020 (0.50)
39-00-0208	5556-SPL			22-28 GA.	.091±.012 (2.30±0.30)	.091±.016 (2.30±0.40)	.024 ±.016 (0.60)±0.40	.071±.012 (1.80±0.30)	.065±.016 (1.65±0.40)	.016 (0.40)
39-00-0209	5556-S2P			16 GA.	.142±.012 (3.60±0.30)	.177±.016 (4.50±0.40)	.035 ±.016 (0.90)±0.40	.091±.012 (2.30±0.30)	.106±.016 (2.70±0.40)	.024 (0.60)
39-00-0210	5556-S2PL				.142±.012 (3.60±0.30)	.177±.016 (4.50±0.40)	.035 ±.016 (0.90)±0.40	.091±.012 (2.30±0.30)	.106±.016 (2.70±0.40)	.024 (0.60)
39-00-0211	5556-S3P				.142±.012 (3.60±0.30)	.177±.016 (4.50±0.40)	.035 ±.016 (0.90)±0.40	.091±.012 (2.30±0.30)	.106±.016 (2.70±0.40)	.024 (0.60)
39-00-0212	5556-S3PL	B PHOS BRONZE	TIN	18-24 GA.	.142±.012 (3.60±0.30)	.177±.016 (4.50±0.40)	.035 ±.016 (0.90)±0.40	.075±.012 (1.90±0.30)	.091±.016 (2.30±0.40)	.020 (0.50)
39-00-0213	5556-PBSP			22-28 GA.	.091±.012 (2.30±0.30)	.091±.016 (2.30±0.40)	.024 ±.016 (0.60)±0.40	.071±.012 (1.80±0.30)	.065±.016 (1.65±0.40)	.016 (0.40)
39-00-0214	5556-PBSPL			16 GA.	.142±.012 (3.60±0.30)	.177±.016 (4.50±0.40)	.035 ±.016 (0.90)±0.40	.091±.012 (2.30±0.30)	.106±.016 (2.70±0.40)	.024 (0.60)
39-00-0215	5556-PBS2P				.142±.012 (3.60±0.30)	.177±.016 (4.50±0.40)	.035 ±.016 (0.90)±0.40	.091±.012 (2.30±0.30)	.106±.016 (2.70±0.40)	.024 (0.60)
39-00-0216	5556-PBS2PL				.142±.012 (3.60±0.30)	.177±.016 (4.50±0.40)	.035 ±.016 (0.90)±0.40	.091±.012 (2.30±0.30)	.106±.016 (2.70±0.40)	.024 (0.60)
39-00-0217	5556-PBS3P			.142±.012 (3.60±0.30)	.177±.016 (4.50±0.40)	.035 ±.016 (0.90)±0.40	.091±.012 (2.30±0.30)	.106±.016 (2.70±0.40)	.024 (0.60)	
39-00-0218	5556-PBS3PL									

**LEGEND:**

5556 - \*\* S \* P \*

BASE NO. \_\_\_\_\_

MATERIAL \_\_\_\_\_

BLANK= BRASS

PB= PHOS. BRONZE

S= TIN OVER NICKEL

PLATING & CRIMP SIZE COMB. \_\_\_\_\_

BLANK THRU 5

CHAIN OR LOOSE \_\_\_\_\_

BLANK= CHAIN

L= LOOSE

**NOTES**

- MATERIAL:  
A= BRASS  
B= PHOS. BRONZE
- FINISH:  
TIN = .000100/(.00254) MIN BRIGHT TIN OVER .000050/(.00127)MIN. NICKEL
- PRODUCT SPECIFICATION: PS-5556-001, PS-5556-002, PS-5556-003.
- PACKAGING SPECIFICATION: PK-5556-001 FOR CHAIN TERMINALS  
PK-5556-003 FOR LOOSE TERMINALS.
- MATES WITH: 5558, 5566, 5569, 30069, 30070, 42440, 42404, 43879, 43810, 44068.
- APPLICABLE HOUSINGS: 5557, 30067, 43760, 44516, OR 42474.
- THE NUMBER OF SERRATIONS TO BE ONE FOR WIRE RANGE #22-28.
- WHEN TERMINALS ARE INSTALLED IN THE HOUSING THE WIRES ARE TO BE DRESSED IN SUCH A MANNER TO ALLOW THE TERMINALS TO FLOAT FREELY IN THE POCKET.
- THIS TERMINAL IS DESIGNED FOR SINGLE WIRE CRIMPING.
- PART CONFORMS TO CLASS "B" REQUIREMENTS OF COSMETIC SPECIFICATION PS-45499-002.
- TEXT ON PART IS FOR REFERENCE ONLY. TEXT AND TEXT LOCATION MAY VARY DEPENDING ON PART NUMBER AND/OR TOOL.

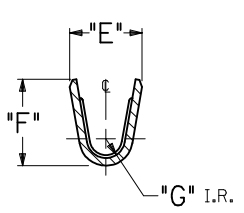
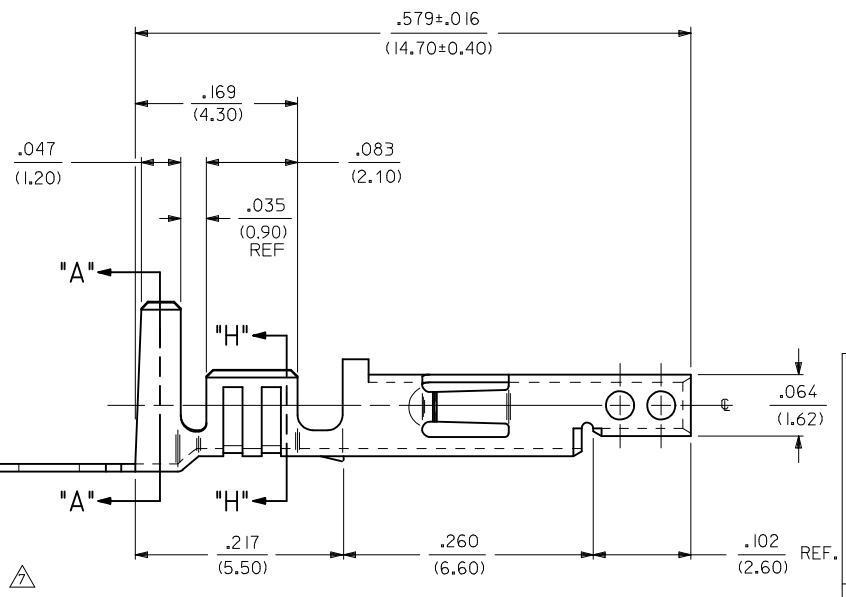
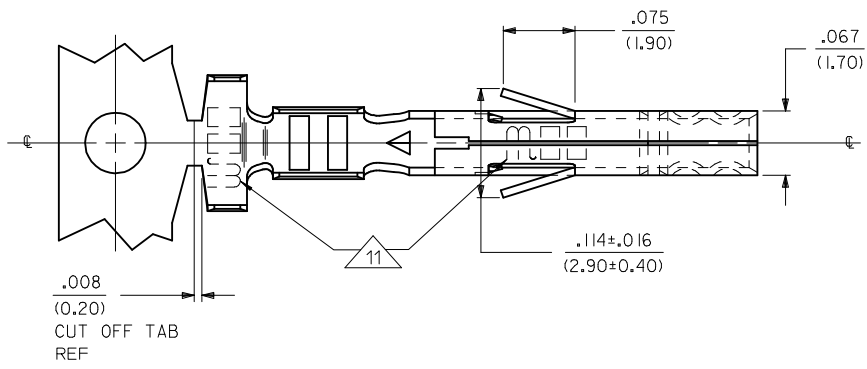

**SECT. "H-H"**

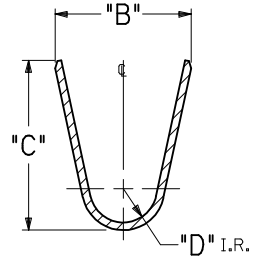

**SECT. "A-A"**

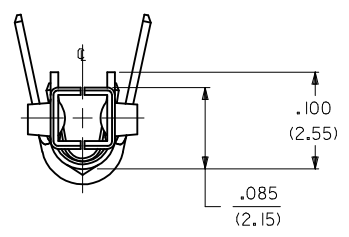

<b>ADD NOTE 11</b> EC NO: UCP2017-2202 DRAWN: SLAFTER 2017/04/05 CHKD: J.BELL 2017/04/05 APPR: F.S.MITH 2017/09/29	QUALITY SYMBOLS ∇=0 ∇=0 ∇=0	GENERAL TOLERANCES (UNLESS SPECIFIED)		DIMENSION STYLE IN/MM		SCALE INCH	DESIGN UNITS INCH	THIRD ANGLE PROJECTION
		4 PLACES ± --- ± --- 3 PLACES ± --- ± .010 2 PLACES ± 0.25 ± .014 1 PLACE ± 0.36 ± --- 0 PLACE ± ±	mm INCH ± --- ± --- ± .010 ± .014 ± 0.36 ± --- ± ±	DRAWN BY GEP	DATE 5/17/1990	TITLE MINI FIT JR OVERALL BRIGHT TIN OVER NICKEL FEMALE CRIMP TERMINAL	MATERIAL NO. SEE CHART	DOCUMENT NO. SD-5556-SP*
DRAFT WHERE APPLICABLE MUST REMAIN WITHIN DIMENSIONS		THIS DRAWING CONTAINS INFORMATION THAT IS PROPRIETARY TO MOLEX INCORPORATED AND SHOULD NOT BE USED WITHOUT WRITTEN PERMISSION						

PART NO.	ENG. NO.	MAT'L.	PLATE	WIRE GAGE	DIM. "B"	DIM. "C"	DIM. "D"	DIM. "E"	DIM. "F"	DIM. "G"
39-00-0207	5556-SP	A BRASS	TIN	18-24 GA.	.142±.012 (3.60±0.30)	.177±.016 (4.50±0.40)	.035 ±.016 (0.90)±0.40	.075±.012 (1.90±0.30)	.091±.016 (2.30±0.40)	.020 (0.50)
39-00-0208	5556-SPL			22-28 GA.	.091±.012 (2.30±0.30)	.091±.016 (2.30±0.40)	.024 ±.016 (0.60)±0.40	.071±.012 (1.80±0.30)	.065±.016 (1.65±0.40)	.016 (0.40)
39-00-0209	5556-S2P			16 GA.	.142±.012 (3.60±0.30)	.177±.016 (4.50±0.40)	.035 ±.016 (0.90)±0.40	.091±.012 (2.30±0.30)	.106±.016 (2.70±0.40)	.024 (0.60)
39-00-0210	5556-S2PL				.142±.012 (3.60±0.30)	.177±.016 (4.50±0.40)	.035 ±.016 (0.90)±0.40	.091±.012 (2.30±0.30)	.106±.016 (2.70±0.40)	.024 (0.60)
39-00-0211	5556-S3P				.142±.012 (3.60±0.30)	.177±.016 (4.50±0.40)	.035 ±.016 (0.90)±0.40	.091±.012 (2.30±0.30)	.106±.016 (2.70±0.40)	.024 (0.60)
39-00-0212	5556-S3PL	B PHOS BRONZE	TIN	18-24 GA.	.142±.012 (3.60±0.30)	.177±.016 (4.50±0.40)	.035 ±.016 (0.90)±0.40	.075±.012 (1.90±0.30)	.091±.016 (2.30±0.40)	.020 (0.50)
39-00-0213	5556-PBSP			22-28 GA.	.091±.012 (2.30±0.30)	.091±.016 (2.30±0.40)	.024 ±.016 (0.60)±0.40	.071±.012 (1.80±0.30)	.065±.016 (1.65±0.40)	.016 (0.40)
39-00-0214	5556-PBSPL			16 GA.	.142±.012 (3.60±0.30)	.177±.016 (4.50±0.40)	.035 ±.016 (0.90)±0.40	.091±.012 (2.30±0.30)	.106±.016 (2.70±0.40)	.024 (0.60)
39-00-0215	5556-PBS2P				.142±.012 (3.60±0.30)	.177±.016 (4.50±0.40)	.035 ±.016 (0.90)±0.40	.091±.012 (2.30±0.30)	.106±.016 (2.70±0.40)	.024 (0.60)
39-00-0216	5556-PBS2PL				.142±.012 (3.60±0.30)	.177±.016 (4.50±0.40)	.035 ±.016 (0.90)±0.40	.091±.012 (2.30±0.30)	.106±.016 (2.70±0.40)	.024 (0.60)
39-00-0217	5556-PBS3P			.142±.012 (3.60±0.30)	.177±.016 (4.50±0.40)	.035 ±.016 (0.90)±0.40	.091±.012 (2.30±0.30)	.106±.016 (2.70±0.40)	.024 (0.60)	
39-00-0218	5556-PBS3PL									

**LEGEND:**

5556 - \*\* S \* P \*

BASE NO. \_\_\_\_\_

MATERIAL \_\_\_\_\_

BLANK= BRASS

PB= PHOS. BRONZE

S= TIN OVER NICKEL

PLATING & CRIMP SIZE COMB. \_\_\_\_\_

BLANK THRU 5

CHAIN OR LOOSE \_\_\_\_\_

BLANK= CHAIN

L= LOOSE

**NOTES**

- MATERIAL:  
A= BRASS  
B= PHOS. BRONZE
- FINISH:  
TIN = .000100/(.00254) MIN BRIGHT TIN OVER .000050/(.00127)MIN. NICKEL
- PRODUCT SPECIFICATION: PS-5556-001, PS-5556-002, PS-5556-003.
- PACKAGING SPECIFICATION: PK-5556-001 FOR CHAIN TERMINALS  
PK-5556-003 FOR LOOSE TERMINALS.
- MATES WITH: 5558, 5566, 5569, 30069, 30070, 42440, 42404, 43879, 43810, 44068.
- APPLICABLE HOUSINGS: 5557, 30067, 43760, 44516, OR 42474.
- THE NUMBER OF SERRATIONS TO BE ONE FOR WIRE RANGE #22-28.
- WHEN TERMINALS ARE INSTALLED IN THE HOUSING THE WIRES ARE TO BE DRESSED IN SUCH A MANNER TO ALLOW THE TERMINALS TO FLOAT FREELY IN THE POCKET.
- THIS TERMINAL IS DESIGNED FOR SINGLE WIRE CRIMPING.
- PART CONFORMS TO CLASS "B" REQUIREMENTS OF COSMETIC SPECIFICATION PS-45499-002.
- TEXT ON PART IS FOR REFERENCE ONLY. TEXT AND TEXT LOCATION MAY VARY DEPENDING ON PART NUMBER AND/OR TOOL.

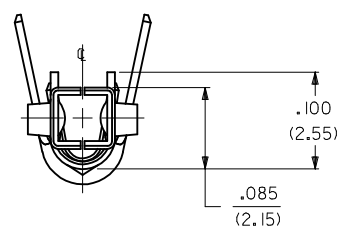
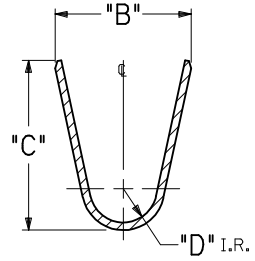
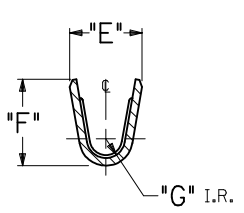
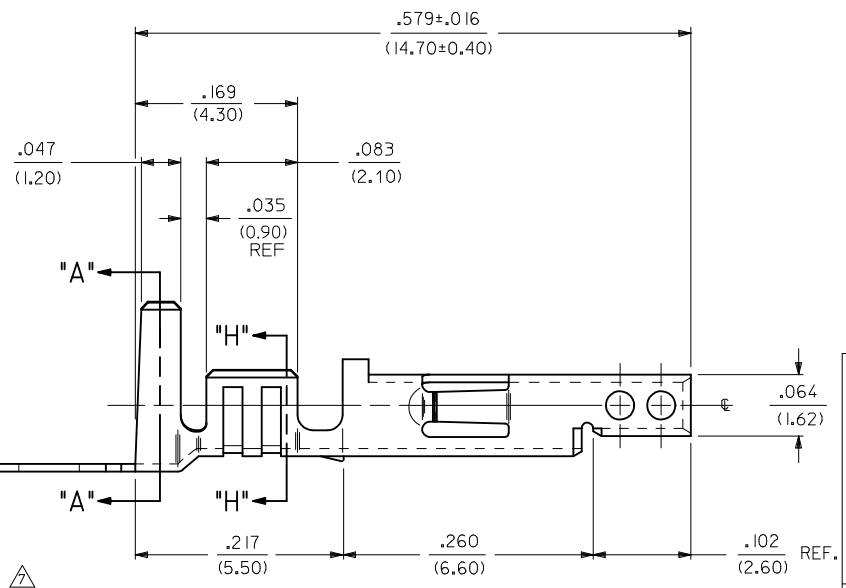
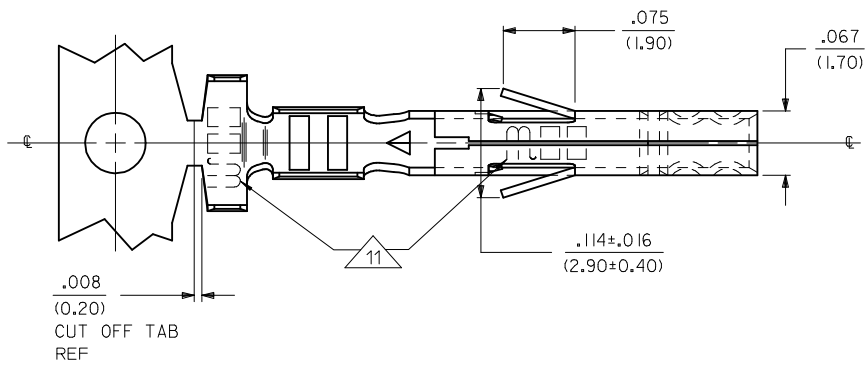

<b>ADD NOTE 11</b> EC NO: UCP2017-2202 DRAWN: SLAFTER 2017/04/05 CHKD: J. BELL 2017/04/05 APPR: F. SMITH 2017/09/29	QUALITY SYMBOLS ∇=0 ∇=0 ∇=0	GENERAL TOLERANCES (UNLESS SPECIFIED)		DIMENSION STYLE IN/MM		SCALE INCH	DESIGN UNITS INCH	THIRD ANGLE PROJECTION
		4 PLACES ± --- ± --- 3 PLACES ± --- ± .010 2 PLACES ± 0.25 ± .014 1 PLACE ± 0.36 ± --- 0 PLACE ± ±	mm INCH DRAWN BY DATE GEP 5/17/1990 CHECKED BY DATE RJF 5/17/1990 APPROVED BY DATE RAS 5/17/1990	TITLE MINI FIT JR OVERALL BRIGHT TIN OVER NICKEL FEMALE CRIMP TERMINAL		MATERIAL NO. <b>SEE CHART</b>		DOCUMENT NO. <b>SD-5556-SP*</b>
DRAFT WHERE APPLICABLE MUST REMAIN WITHIN DIMENSIONS		THIS DRAWING CONTAINS INFORMATION THAT IS PROPRIETARY TO MOLEX INCORPORATED AND SHOULD NOT BE USED WITHOUT WRITTEN PERMISSION						

单击下面可查看定价，库存，交付和生命周期等信息

[>>MOLEX](#)