

COMPONENT KEEP OUT AREA FOR CARD HOLD DOWN SOLUTION

- NOTES:
- MATERIALS:
HOUSING:LCP,COLOR:BLACK, UL94V-0.
CONTACT: PHOSPHOR BRONZE NAIL:BRASS
 - FINISH
CONTACT:SELECTIVE GOLD IN CONTACT AND SOLDER AREA.
UNDERPLATED:NICKEL OVERALL
NAIL:TIN IN SOLDER AREA.
UNDERPLATED:NICKEL OVERALL.
 - THE MODULE CARD REFERENCE MINI PCI EXPRESS CARD ELECTROMECHANICAL SPECIFICATION.
 - DATUM D IS THE TOP SURFACE OF PCB.
 - IF THE CONNECTOR USED WITH 48099-00**,LATCH SIDE RECOMMENDED PCB LAYOUT REFERS TO SD-48099-0**.
 - PART 67910**** COMPLIANT TO ROHS DIRECTIVE 2002/95/EC AND ELV DIRECTIVE 2000/53/EC.

679100002	10 MICROINCH GOLD
679101002	GOLD FLASH

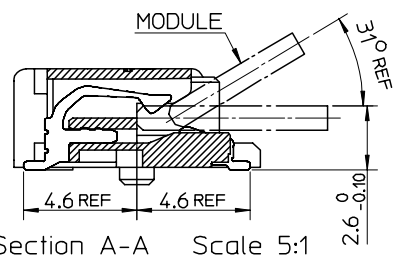

RELEASED EC NO: SH2007-0020 2006/08/02 DRWN:DHU 2006/08/02 CHKD:HARVEY 2006/08/02 APPR: INCHEN 2006/08/09	DESCRIPTION	QUALITY SYMBOLS	GENERAL TOLERANCES (UNLESS SPECIFIED)	DIMENSION STYLE	SCALE	DESIGN UNITS	THIRD ANGLE PROJECTION													
		$\nabla=0$ $\sphericalangle=0$	<table border="1"> <thead> <tr> <th></th> <th>mm</th> <th>INCH</th> </tr> </thead> <tbody> <tr> <td>4 PLACES</td> <td>± ---</td> <td>± ---</td> </tr> <tr> <td>3 PLACES</td> <td>± ---</td> <td>± ---</td> </tr> <tr> <td>2 PLACES</td> <td>± 0.25</td> <td>± ---</td> </tr> <tr> <td>1 PLACE</td> <td>± 0.25</td> <td>± ---</td> </tr> </tbody> </table>		mm	INCH	4 PLACES	± ---	± ---	3 PLACES	± ---	± ---	2 PLACES	± 0.25	± ---	1 PLACE	± 0.25	± ---	MM ONLY	2:1
	mm	INCH																		
4 PLACES	± ---	± ---																		
3 PLACES	± ---	± ---																		
2 PLACES	± 0.25	± ---																		
1 PLACE	± 0.25	± ---																		
DRAWN BY J. CHIANG 2003/02/25		DATE		TITLE MINI PCI EXPRESS CONN. 0.8 MM PITCH 52CIRCUIT 4.0MM H																
CHECKED BY C. WILSON 2003/03/06		DATE		MOLEX INCORPORATED																
APPROVED BY L. ERICK 2003/03/06		DATE		DOCUMENT NO. SD-67910-001		SHEET NO. 1 OF 2														
MATERIAL NO.		SEE TABLE		THIS DRAWING CONTAINS INFORMATION THAT IS PROPRIETARY TO MOLEX INCORPORATED AND SHOULD NOT BE USED WITHOUT WRITTEN PERMISSION																

10 9 8 7 6 5 4 3 2 1

NOTES;

1. PIN NUMBERING REFERENCE:

ODD PINS - TOP SIDE
EVEN PINS - BOTTOM SIDE

- △ COMPONENT AND ROUTING (ALL LAYERS)
KEEP OUT AREA FOR HOLD DOWN SOLUTIONS.
- △ COMPONENT KEEP OUT AREA FOR CONNECTOR.

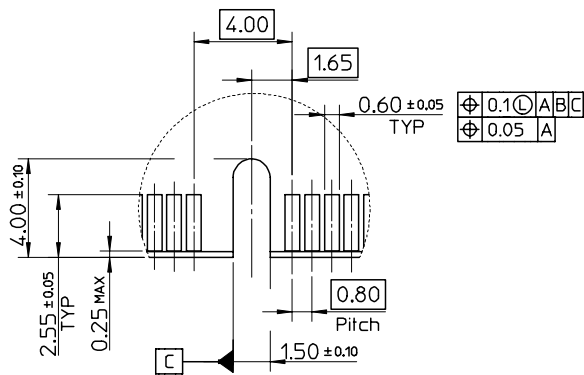
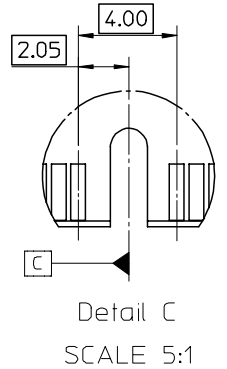
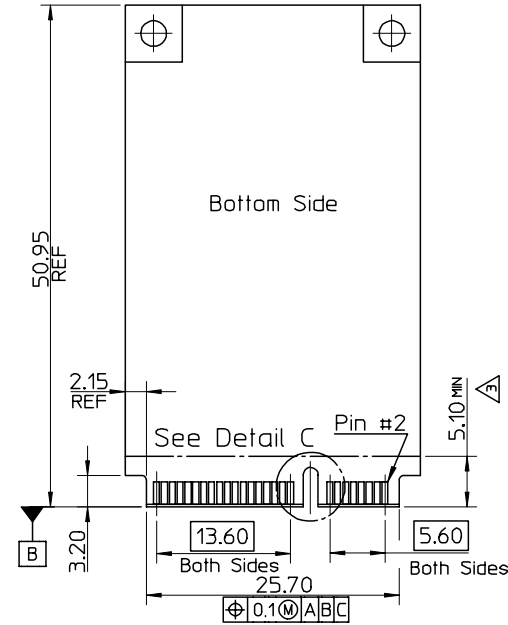
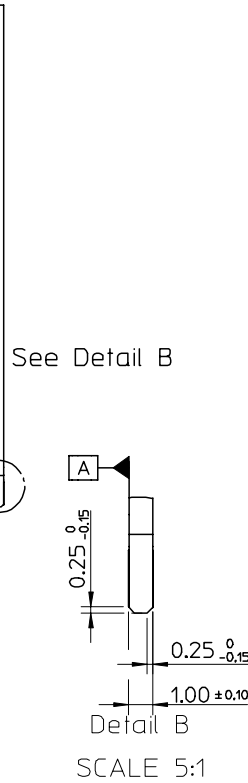
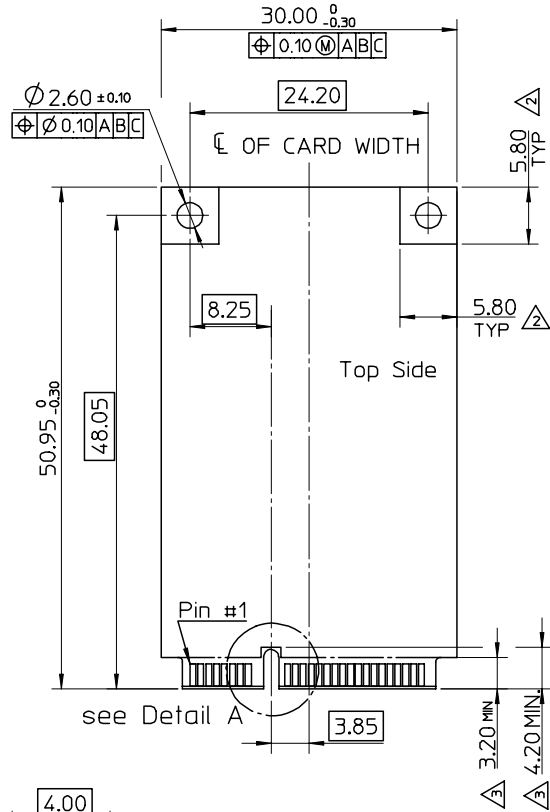

Detail A
Scale 5:1

RELEASED EC NO: SH2007-0020 2006/08/02 DRWN:DHU CHKD:HARVEY 2006/08/02 APPR: JNCHEM 2006/08/09	QUALITY SYMBOLS ▽=0 △=0	GENERAL TOLERANCES (UNLESS SPECIFIED)		DIMENSION STYLE MM ONLY	SCALE 1:1	DESIGN UNITS METRIC	THIRD ANGLE PROJECTION
		4 PLACES ± --- ± ---	3 PLACES ± --- ± ---	2 PLACES ± 0.25 ± ---	1 PLACE ± 0.25 ± ---	ANGULAR ± 3 °	DRAWN BY J. CHIANG 2003/02/25
REV C	DESCRIPTION	DRAFT WHERE APPLICABLE MUST REMAIN WITHIN DIMENSIONS		SEE TABLE	APPROVED BY L. ERICK 2003/03/06	DATE 2003/03/06	MOLEX INCORPORATED
		SIZE A3	THIS DRAWING CONTAINS INFORMATION THAT IS PROPRIETARY TO MOLEX INCORPORATED AND SHOULD NOT BE USED WITHOUT WRITTEN PERMISSION		MATERIAL NO.	DOCUMENT NO. SD-67910-001	SHEET NO. 2 OF 2

单击下面可查看定价，库存，交付和生命周期等信息

[>>MOLEX](#)