

GENERAL TOLERANCE									USED ON	
10 MAX	30 MAX	50 MAX	70 MAX	100 MAX	120 MAX	250 MAX	250 OVER	ANGLE		ECCENT
±0.15	±0.20	±0.30	±0.40	±0.50	±0.75	±0.90	±1.4	±0.5°	0.1	

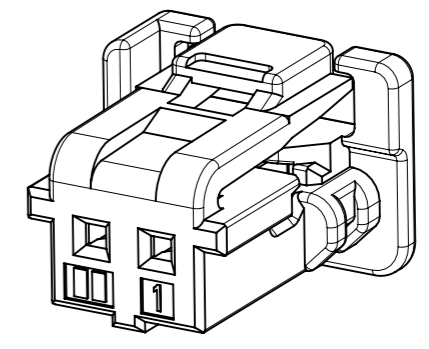

ISO VIEW

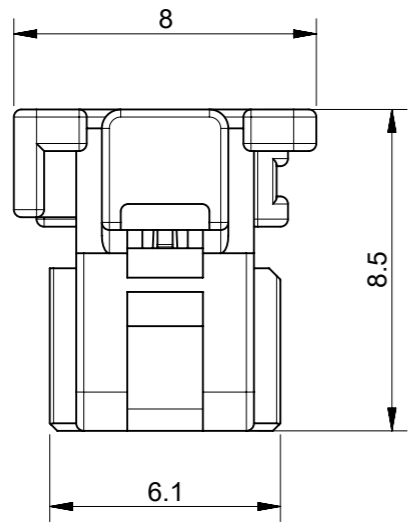
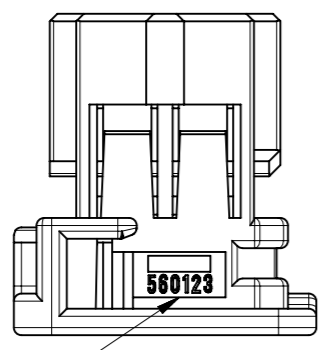
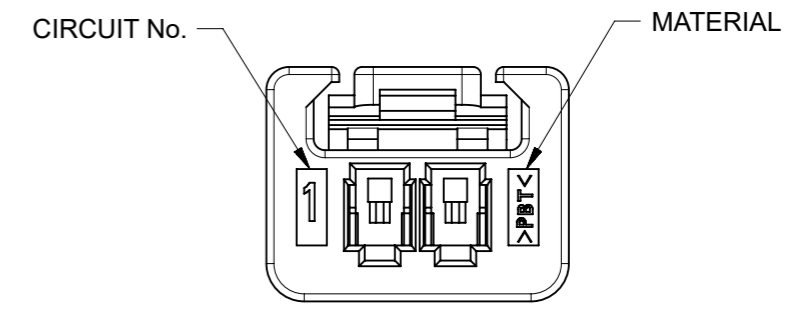
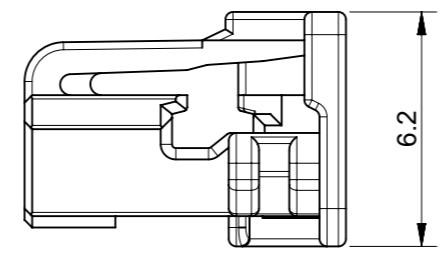
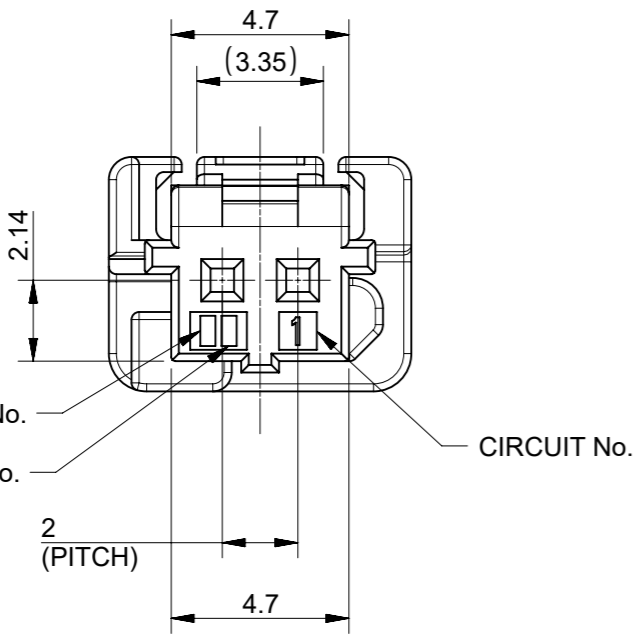

SERIES No.

- NOTES:
1. MATERIALS : POLYESTER (PBT), GLASS UNFILLED, UL94 V-0
  2. MATE WITH : 502352, 560020 SERIES
  3. APPLICABLE TERMINAL : 560124 SERIES
  4. APPLICABLE ISL : 560125 SERIES
  5. GENERAL TOLERANCE : SEE TABLE
  6. EVL AND RoHS COMPLIANT
  7. PRODUCT SPECIFICATION : PS-560123-00\*
  8. PACKING SPECIFICATION : PK-560123-001

MATERIAL NUMBER

ORDER NO.	MATERIAL NO.	COLOR
560123-0200	5601230200	WHITE
560123-0201	5601230201	BLACK
560123-0202	5601230202	RED
560123-0204	5601230204	BLUE

FUNCTIONAL SYMBOLS	THIS DRAWING CONTAINS INFORMATION THAT IS PROPRIETARY TO MOLEX ELECTRONIC TECHNOLOGIES, LLC AND SHOULD NOT BE USED WITHOUT WRITTEN PERMISSION	CURRENT REV DESC:				
	$\nabla_A = 0$ $\nabla_E = 0$ $\nabla_V = 0$	DIMENSION UNITS: <b>mm</b> SCALE: <b>5:1</b>	EC NO: 668822 DRWN: SAKIM CHK'D: HIJIMA APPR: HIJIMA			
DIVISIONAL SYMBOLS	GENERAL TOLERANCES (UNLESS SPECIFIED)	INITIAL REVISION:		PRODUCT CUSTOMER DRAWING		
	ANGULAR TOL ± ° 4 PLACES ± 3 PLACES ± 2 PLACES ± 1 PLACE ± 0 PLACES ±	DRWN: YIBAEK APPR: SRTAK	2014/07/03 2014/08/26	DOCUMENT NUMBER: <b>SD-560123-001</b> DOC TYPE: PSD DOC PART: 001 REVISION: C3	MATERIAL NUMBER: SEE TABLE CUSTOMER: GENERAL MARKET SHEET NUMBER: 1 OF 1	
DRAFT WHERE APPLICABLE MUST REMAIN WITHIN DIMENSIONS		THIRD ANGLE PROJECTION	DRAWING: A3-SIZE	SERIES: 560123		

单击下面可查看定价，库存，交付和生命周期等信息

[>>MOLEX](#)