

MSKSEMI 美森科

SEMICONDUCTOR



ESD



TVS



TSS

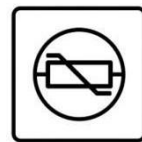

MOV



GDT



PLED

BTA12-XXXB(MS)

Product specification



DESCRIPTION

The BTA12-XXXB(MS) series with the parallel resistor between Gate and Cathode are especially recommended for use on straight hair, igniter, anion generator, etc.

MAIN FEATURES

Symbol	Value	Unit
$I_{T(RMS)}$	12	A
V_{DRM} / V_{RRM}	600/800	V

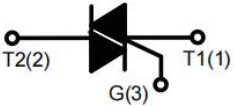
Reference News

PACKAGE OUTLINE	Pin Configuration	Marking	
			
		BTA12-600B(MS)	BTA12-800B(MS))

Notes :XXX represents the order code.

ABSOLUTE MAXIMUM RATINGS

Parameter	Symbol	Value	Unit
Storage junction temperature range	T_{stg}	-40-150	°C
Operating junction temperature range	T_j	-40-125	°C
Repetitive peak off-state voltage ($T_j=25^\circ\text{C}$)	V_{DRM}	600/800	V
Repetitive peak reverse voltage ($T_j=25^\circ\text{C}$)	V_{RRM}	600/800	V
Non repetitive surge peak Off-state voltage	V_{DSM}	$V_{DRM} + 100$	V
Non repetitive peak reverse voltage	V_{RSM}	$V_{RRM} + 100$	V
RMS on-state current($TC=85^\circ\text{C}$)	$I_{T(RMS)}$	12	A
Non repetitive surge peak on-state current (full cycle, $F=50\text{Hz}$)	I_{TSM}	120	A
Pt value for fusing ($tp=10\text{ms}$)	Pt	78	A^2s
Critical rate of rise of on-state current ($I_G = 2 \times I_{GT}$)	I - II-III di/dt	50	$\text{A}/\mu\text{s}$
Peak gate current	I_{GM}	4	A
Average gate power dissipation	$P_{G(AV)}$	1	W
Peak gate power	P_{GM}	5	W

ELECTRICAL CHARACTERISTICS ($T_j=25^\circ\text{C}$ unless otherwise specified)

3 Quadrants

Symbol	Test Condition	Quadrant		Value	Unit
I_{GT}	$V_D = 12\text{V}$ $R_L = 33\Omega$	I - II-III	MAX	50	mA
V_{GT}		I - II-III	MAX	1.3	V
V_{GD}	$V_D = V_{DRM}$ $T_j = 125^\circ\text{C}$ $R_L = 3.3\text{K}\Omega$	I - II-III	MIN	0.2	V
I_L	$I_G = 1.2I_{GT}$	I -III	MAX	80	mA
		II		90	
I_H	$I_r = 100\text{mA}$		MAX	60	mA
dV/dt	$V_D = 2/3V_{DRM}$ Gate Open $T_j = 125^\circ\text{C}$		MIN	1000	V/ μs
(dI/dt) _c	Without snubber $T_j = 125^\circ\text{C}$		MIN	12	A/ms

4 Quadrants

Symbol	Test Condition	Quadrant		Value	Unit
I_{GT}	$V_D = 12\text{V}$ $R_L = 33\Omega$	I - II-III	MAX	50	mA
		IV		70	
V_{GT}		ALL	MAX	1.3	V
V_{GD}	$V_D = V_{DRM}$ $T_j = 125^\circ\text{C}$ $R_L = 3.3\text{K}\Omega$	ALL	MIN	0.2	V
I_L	$I_G = 1.2I_{GT}$	I -III-IV	MAX	50	mA
		II		100	
I_H	$I_r = 100\text{mA}$		MAX	50	mA
dV/dt	$V_D = 2/3V_{DRM}$ Gate Open $T_j = 125^\circ\text{C}$		MIN	500	V/ μs
(dV/dt) _c	(dI/dt) _c = 5.3A/ms $T_j = 125^\circ\text{C}$		MIN	10	V/ μs

STATIC CHARACTERISTICS

Symbol	Parameter		Value(MAX)	Unit
V_{TM}	$I_{TM} = 17\text{A}$ $t_p = 380\mu\text{s}$	$T_j = 25^\circ\text{C}$	1.5	V
I_{DRM}	$V_D = V_{DRM}$ $V_R = V_{RRM}$	$T_j = 25^\circ\text{C}$	5	μA
I_{RRM}		$T_j = 125^\circ\text{C}$	1	mA

THERMAL RESISTANCES

Symbol	Parameter	Value	Unit
$R_{th(j-c)}$	junction to case(AC)	2.3	$^\circ\text{C/W}$

FIG.1 Maximum power dissipation versus RMS on-state current

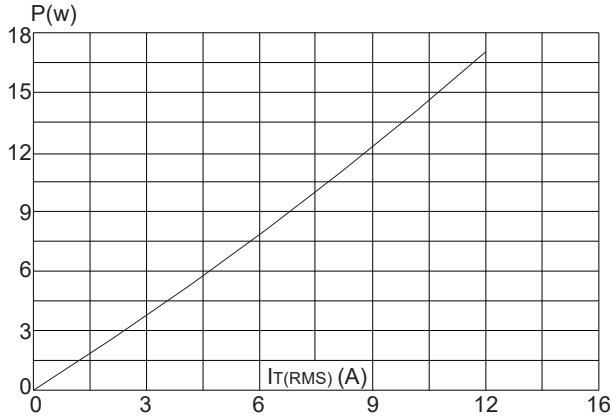

FIG.2: RMS on-state current versus case temperature

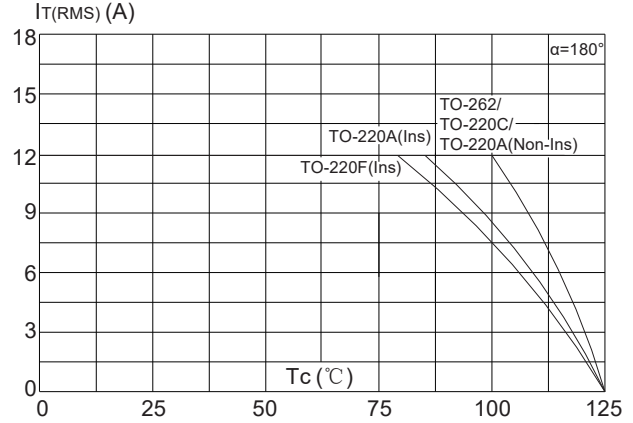

FIG.3: Surge peak on-state current versus number of cycles

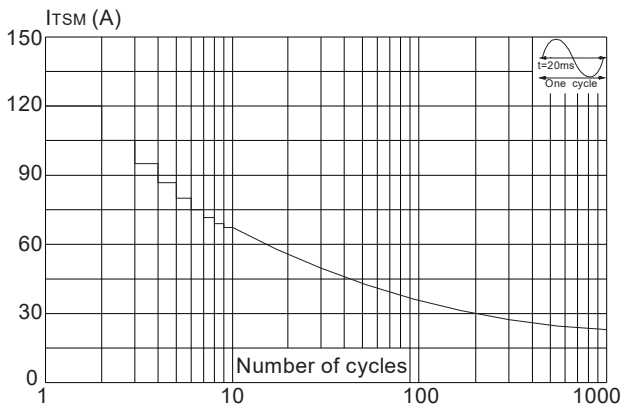

FIG.4: On-state characteristics (maximum values)

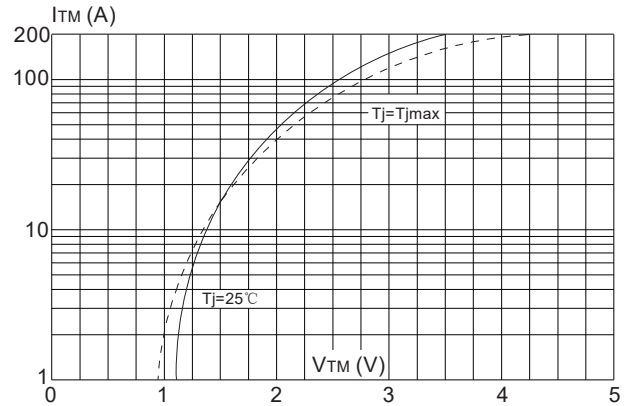

FIG.5: Non-repetitive surge peak on-state current for a sinusoidal pulse with width $t_p < 20ms$, and corresponding value of I^2t ($dI/dt(I-II-III) < 50A/\mu s$)

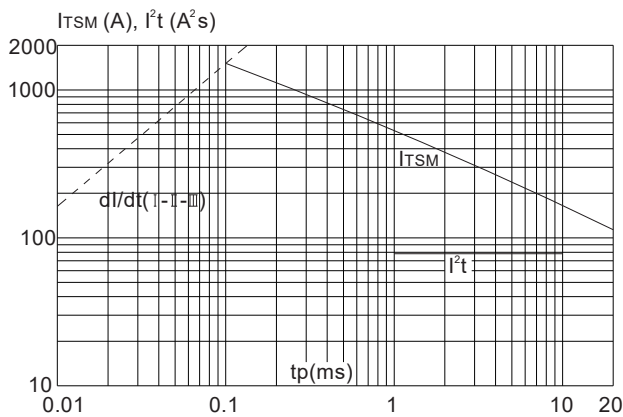
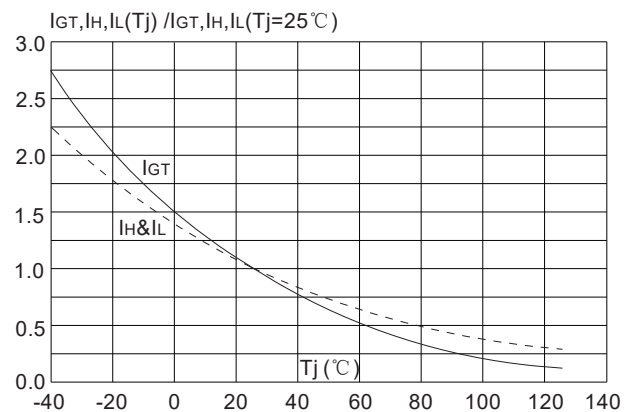
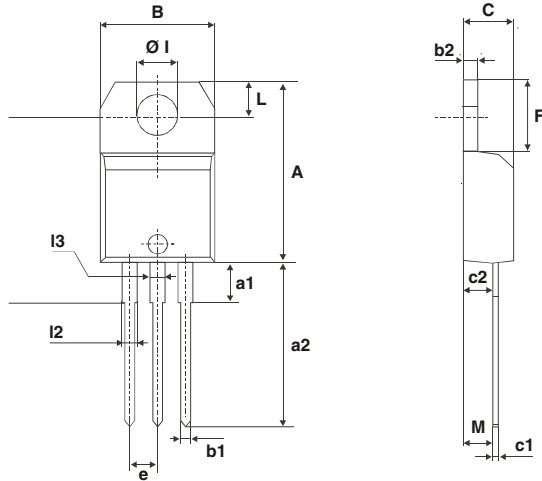

FIG.6: Relative variations of gate trigger current, holding current and latching current versus junction temperature



PACKAGE MECHANICAL DATA



REF.	DIMENSIONS					
	Millimeters			Inches		
	Min.	Typ.	Max.	Min.	Typ.	Max.
A	15.20		15.90	0.598		0.625
a1		3.75			0.147	
a2	13.00		14.00	0.511		0.551
B	10.00		10.40	0.393		0.409
b1	0.61		0.88	0.024		0.034
b2	1.23		1.32	0.048		0.051
C	4.40		4.60	0.173		0.181
c1	0.49		0.70	0.019		0.027
c2	2.40		2.72	0.094		0.107
e	2.40		2.70	0.094		0.106
F	6.20		6.60	0.244		0.259
ØI	3.75		3.85	0.147		0.151
l4	15.80	16.40	16.80	0.622	0.646	0.661
L	2.65		2.95	0.104		0.116
l2	1.14		1.70	0.044		0.066
l3	1.14		1.70	0.044		0.066
M		2.60			0.102	

REEL SPECIFICATION

P/N	PKG	QTY
BTA12-XXXB(MS)	TO-220	50/One tube 1000/a box of

Attention

- Any and all MSKSEMI Semiconductor products described or contained herein do not have specifications that can handle applications that require extremely high levels of reliability, such as life-support systems, aircraft's control systems, or other applications whose failure can be reasonably expected to result in serious physical and/or material damage. Consult with your MSKSEMI Semiconductor representative nearest you before using any MSKSEMI Semiconductor products described or contained herein in such applications.
- MSKSEMI Semiconductor assumes no responsibility for equipment failures that result from using products at values that exceed, even momentarily, rated values (such as maximum ratings, operating condition ranges, or other parameters) listed in products specifications of any and all MSKSEMI Semiconductor products described or contained herein.
- Specifications of any and all MSKSEMI Semiconductor products described or contained herein stipulate the performance, characteristics, and functions of the described products in the independent state, and are not guarantees of the performance, characteristics, and functions of the described products as mounted in the customer's products or equipment. To verify symptoms and states that cannot be evaluated in an independent device, the customer should always evaluate and test devices mounted in the customer's products or equipment.
- MSKSEMI Semiconductor strives to supply high-quality high-reliability products. However, any and all semiconductor products fail with some probability. It is possible that these probabilistic failures could give rise to accidents or events that could endanger human lives, that could give rise to smoke or fire, or that could cause damage to other property. When designing equipment, adopt safety measures so that these kinds of accidents or events cannot occur. Such measures include but are not limited to protective circuits and error prevention circuits for safe design, redundant design, and structural design.
- In the event that any or all MSKSEMI Semiconductor products (including technical data, services) described or contained herein are controlled under any of applicable local export control laws and regulations, such products must not be exported without obtaining the export license from the authorities concerned in accordance with the above law.
- No part of this publication may be reproduced or transmitted in any form or by any means, electronic or mechanical, including photocopying and recording, or any information storage or retrieval system, or otherwise, without the prior written permission of MSKSEMI Semiconductor.
- Information (including circuit diagrams and circuit parameters) herein is for example only ; it is not guaranteed for volume production. MSKSEMI Semiconductor believes information herein is accurate and reliable, but no guarantees are made or implied regarding its use or any infringements of intellectual property rights or other rights of third parties.
- Any and all information described or contained herein are subject to change without notice due to product/technology improvement, etc. When designing equipment, refer to the "Delivery Specification" for the MSKSEMI Semiconductor product that you intend to use.

单击下面可查看定价，库存，交付和生命周期等信息

[>>MSKSEMI\(美森科\)](#)