

Crystal Units





EU RoHS Compliant

- All the products in this catalog comply with EU RoHS.
- EU RoHS is "the European Directive 2011/65/EU on the Restriction of the Use of Certain Hazardous Substances in Electrical and Electronic Equipment."
- For more details, please refer to our web page, "Murata's Approach for EU RoHS" (<https://www.murata.com/en-eu/support/compliance/rohs>).

Contents

Product specifications are as of December 2020.

Bluetooth® is a registered trademark or trademark of Bluetooth SIG, Inc. in the United States and other countries.

Selection Guide	p2
Part Numbering	p3
<hr/>	
1 Crystal Units for Consumer and Industrial	
Features, Applications	p4
Appearance, Dimension	p4
Series	p4
Part Number List	p5
Standard Land Pattern Dimensions	p7
Notice	p8
Packaging	p10
<hr/>	
2 Crystal Units for Automotive	
Features, Applications	p11
Appearance, Dimension	p11
Series	p12
Part Number List	p12
Standard Land Pattern Dimensions	p13
Notice	p14
Packaging	p16
<hr/>	
Measuring Circuit of Crystal Units	p17

Please check the MURATA website (<https://www.murata.com/>) if you cannot find a part number in this catalog.

Selection Guide

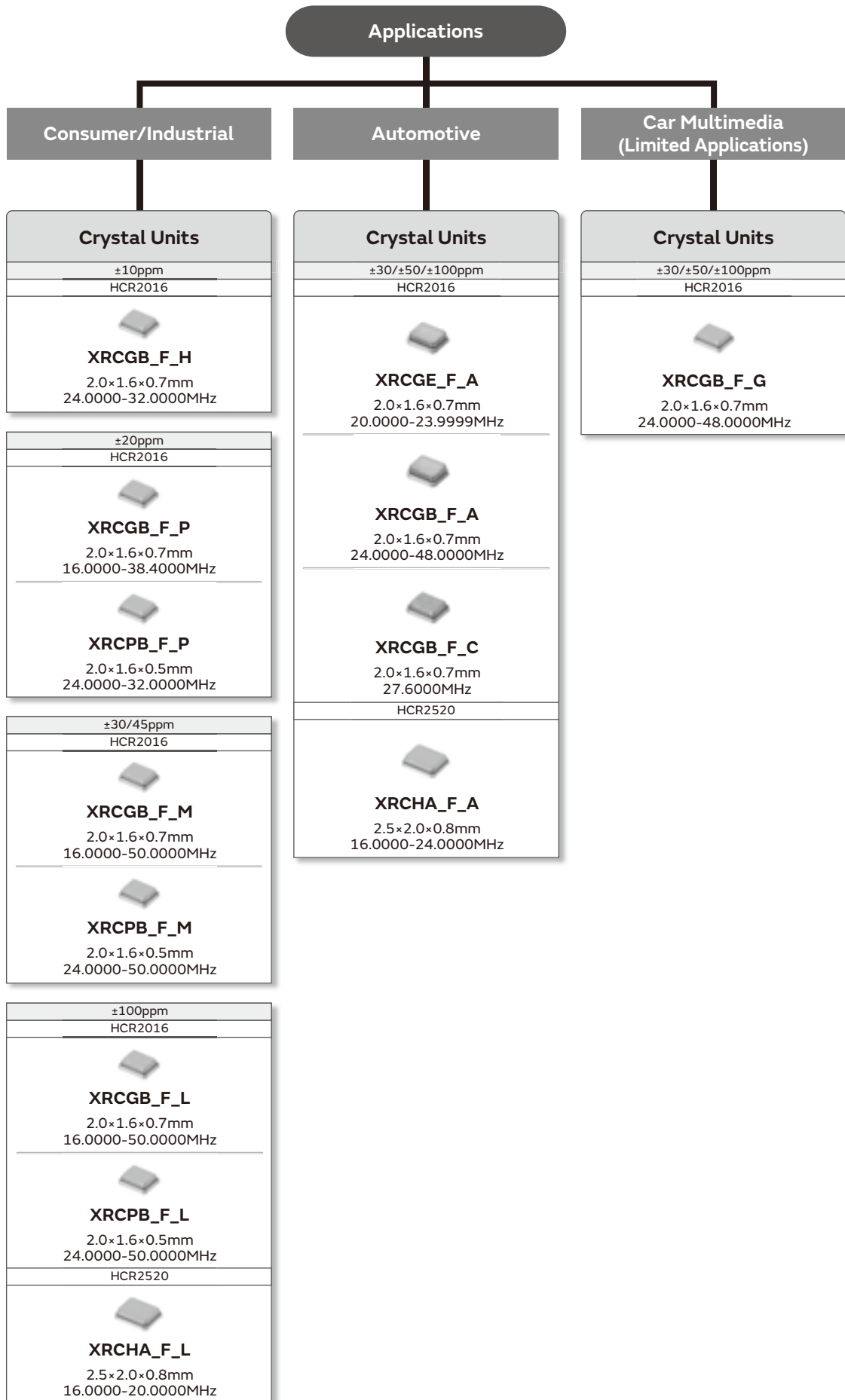

● Part Numbering

Crystal Unit

(Part Number)

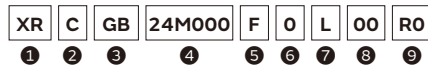

① Product ID

Product ID	
XR	Crystal Unit

② Lead Style

Code	Lead Style
C	SMD

③ Size · Structure

Code	Size · Structure
GB/GE	2016 (STD) Resin Sealing 4pad
PB	2016 (Low Profile) Resin Sealing 4pad
HA	2520 (STD) Resin Sealing 2pad

④ Nominal Center Frequency

Expressed by six-digit alphanumeric. The unit is in hertz (Hz).
 Decimal point is expressed by capital letter "M".

⑤ Overtone Order

Code	Overtone Order
F	Fundamental
K	Customized Fundamental

⑥ Frequency Tolerance

Code	Frequency Tolerance
0	±100ppm
1	±10ppm
2	±20ppm
3	±30ppm
4	±45ppm
5	±50ppm
A	±25ppm
X	Total Frequency Tolerance*1

*1 Including Initial Tolerance+Temperature Characteristics

⑦ Frequency Shift by Temperature

Code	Frequency Shift by Temperature
A/C	±100ppm max. (Automotive Grade)
G	±50ppm (Car Multimedia Grade)
L	±50ppm min.
M	±40ppm
N	±25ppm or 30ppm
P	±20ppm
H/Q	±10ppm to ±15ppm
S	±10ppm or 20ppm

⑧ Individual Specification

Code	
**	Two-digit alphanumerics express Individual Specification.

00: Standard specification type.

⑨ Packaging (Quantity and Plastic taping reel diameter are expressed by one-digit number in "**")

Code	Packaging
R*/E*/J*/P*	Plastic Taping

Crystal Units

for Consumer and Industrial



These crystal units feature a small package and highly accurate frequency, based on Murata's excellent package technology and high grade quartz crystal elements.

Features

1. This series is ideal for applications requiring high accuracy crystal units, especially communication clocks such as Wi-Fi, Bluetooth®, Bluetooth® Low Energy, SATA and USB3.0.
2. The crystal units are extremely small, contributing to a reduction in the mounting area.
3. The series complies to RoHS directive, being lead-free (phase 3).

Applications

1. Clock for Wi-Fi, Bluetooth® and ACPU controller ICs: smartphone, wearable device, module, etc.
2. Clock for Bluetooth® Low Energy controller ICs: wearable, fitness and healthcare devices, module, etc.
3. Storage devices with SATA interface: HDD, SSD, Optical storage device, etc.
4. Clock for USB (Ultra-Speed and High-Speed) controller ICs: Mobile phone, DVC, DSC, Portable audio, PC peripheral, etc.
5. Clock for PC, visual equipment controller ICs
6. Audio equipment and musical instrument, etc.
7. Clock for PLC, Inverter, Servo Amp, Servo Motor, etc. controller ICs
8. Clock for LCD, Programmable display and Visual equipment controller ICs
9. Other applications for replacement of other crystal units or oscillators.

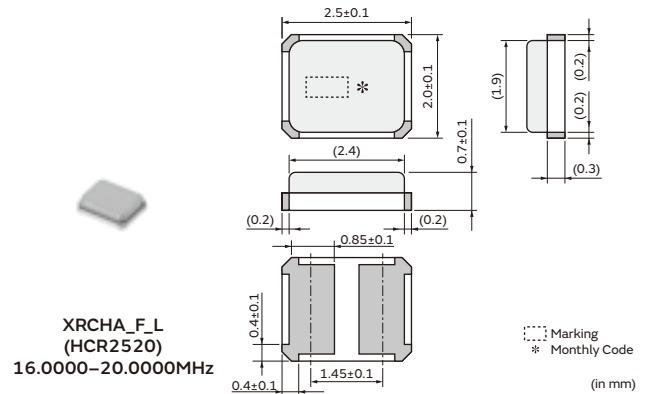
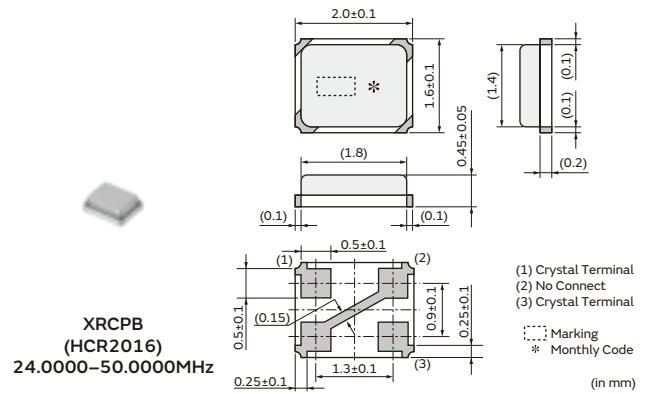
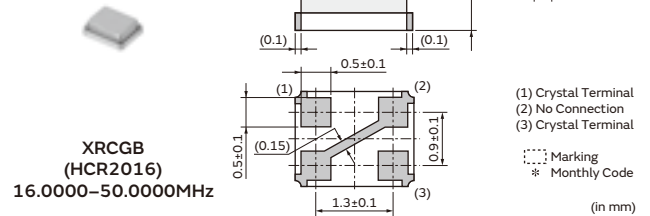

Series

Series	Type	Package	Frequency (MHz)	Frequency Tolerance (ppm max.) [at 25°C±3°C]	Frequency Shift by Temperature (ppm max.) [Standard Condition: +25°C]	Frequency Aging (ppm max./Year)	Drive Level (µW max.)	Operating Temperature Range (°C)		
XRCGB_F_H	HCR2016	Resin	24.0000 to 25.0000	±10	±10	±2	300	-20 to +70		
XRCGB_F_S			26.0000 to 32.0000					-30 to +85		
XRCGB_F_P			37.4000 to 40.0000					-40 to +105		
XRCPB_F_P					16.0000	±40 (Total)		±5	300*1	-30 to +85
XRCGB_F_M			24.0000 to 38.4000	±20	±20					
XRCPB_F_M			16.0000 to 50.0000	±30/±45	±40					
XRCGB_F_L			24.0000 to 50.0000		±50					
XRCPB_F_L			16.0000 to 50.0000	±100	±50					
XRCHA_F_L			HCR2520		16.0000 to 20.0000	±100	±100			

XRCPB series is a low profile type of XRCGB series.

*1 16MHz: 100µW max.

Part Number List

<XRCGB_F_H>

Part Number	Type	Frequency (MHz)	Frequency Tolerance (ppm max.) [at 25°C±3°C]	Frequency Shift by Temperature (ppm max.) [Standard Condition: +25°C]	Frequency Aging (ppm max./Year)	ESR* (Ωmax.)	Load Capacitance (pF)	Drive Level (μW max.)
XRCGB24M000F1H00R0	HCR2016	24.0000	±10	±10 (-20 to +70°C)	±2	80	6	300
XRCGB25M000F1H00R0	HCR2016	25.0000	±10	±10 (-20 to +70°C)	±2	80	6	300
XRCGB26M000F1H00R0	HCR2016	26.0000	±10	±10 (-30 to +85°C)	±2	60	6	300
XRCGB32M000F1H00R0	HCR2016	32.0000	±10	±10 (-30 to +85°C)	±2	60	6	300

* Equivalent Series Resistance

<XRCGB_F_S>

Part Number	Type	Frequency (MHz)	Frequency Tolerance (ppm max.) [at 25°C±3°C]	Frequency Shift by Temperature (ppm max.) [Standard Condition: +25°C]	Frequency Aging (ppm max./Year)	ESR* (Ωmax.)	Load Capacitance (pF)	Drive Level (μW max.)
XRCGB37M400F1S1AR0	HCR2016	37.4000	±10	±10 (-30 to +85°C)	±2	60	6	300
XRCGB37M400F1S2FR0	HCR2016	37.4000	±10	±20 (-40 to +105°C)	±2	60	6	300
XRCGB38M400F1S1AR0	HCR2016	38.4000	±10	±10 (-30 to +85°C)	±2	60	6	300
XRCGB38M400F1S2FR0	HCR2016	38.4000	±10	±20 (-40 to +105°C)	±2	60	6	300
XRCGB40M000F1S1AR0	HCR2016	40.0000	±10	±10 (-30 to +85°C)	±2	60	6	300
XRCGB40M000F1S2FR0	HCR2016	40.0000	±10	±20 (-40 to +105°C)	±2	60	6	300

* Equivalent Series Resistance

<XRCGB_F_P/XRCPB_F_P>

Part Number	Type	Frequency (MHz)	Frequency Tolerance (ppm max.) [at 25°C±3°C]	Frequency Shift by Temperature (ppm max.) [Standard Condition: +25°C]	Frequency Aging (ppm max./Year)	ESR* (Ωmax.)	Load Capacitance (pF)	Drive Level (μW max.)
XRCGB16M000FXN01R0	HCR2016	16.0000	±40ppm (Total)(-30 to +85°C)		±5	200	8	100
XRCGB24M000F2P00R0	HCR2016	24.0000	±20	±20 (-30 to +85°C)	±5	150	6	300
XRCGB25M000F2P00R0	HCR2016	25.0000	±20	±20 (-30 to +85°C)	±5	150	6	300
XRCGB26M000F2P00R0	HCR2016	26.0000	±20	±20 (-30 to +85°C)	±5	150	6	300
XRCGB27M000F2P00R0	HCR2016	27.0000	±20	±20 (-30 to +85°C)	±5	150	6	300
XRCGB27M120F2P00R0	HCR2016	27.1200	±20	±20 (-30 to +85°C)	±5	150	6	300
XRCGB30M000F2P00R0	HCR2016	30.0000	±20	±20 (-30 to +85°C)	±5	100	6	300
XRCGB31M250F2P00R0	HCR2016	31.2500	±20	±20 (-30 to +85°C)	±5	100	6	300
XRCGB32M000F2P00R0	HCR2016	32.0000	±20	±20 (-30 to +85°C)	±5	100	6	300
XRCGB38M400F2P00R0	HCR2016	38.4000	±20	±20 (-30 to +85°C)	±5	100	6	300
XRCPB24M000F2P00R0	HCR2016	24.0000	±20	±20 (-30 to +85°C)	±5	150	6	300
XRCPB25M000F2P00R0	HCR2016	25.0000	±20	±20 (-30 to +85°C)	±5	150	6	300
XRCPB26M000F2P00R0	HCR2016	26.0000	±20	±20 (-30 to +85°C)	±5	150	6	300
XRCPB27M000F2P00R0	HCR2016	27.0000	±20	±20 (-30 to +85°C)	±5	150	6	300
XRCPB27M120F2P00R0	HCR2016	27.1200	±20	±20 (-30 to +85°C)	±5	150	6	300
XRCPB30M000F2P00R0	HCR2016	30.0000	±20	±20 (-30 to +85°C)	±5	100	6	300
XRCPB31M250F2P00R0	HCR2016	31.2500	±20	±20 (-30 to +85°C)	±5	100	6	300
XRCPB32M000F2P00R0	HCR2016	32.0000	±20	±20 (-30 to +85°C)	±5	100	6	300

* Equivalent Series Resistance

<XRCGB_F_M/XRCPB_F_M>

Part Number	Type	Frequency (MHz)	Frequency Tolerance (ppm max.) [at 25°C±3°C]	Frequency Shift by Temperature (ppm max.) [Standard Condition: +25°C]	Frequency Aging (ppm max./Year)	ESR* (Ωmax.)	Load Capacitance (pF)	Drive Level (μW max.)
XRCGB24M000F3M00R0	HCR2016	24.0000	±30	±40 (-30 to +85°C)	±5	150	6	300
XRCGB24M576F3M00R0	HCR2016	24.5760	±30	±40 (-30 to +85°C)	±5	150	6	300
XRCGB25M000F3M00R0	HCR2016	25.0000	±30	±40 (-30 to +85°C)	±5	150	6	300
XRCGB26M000F3M00R0	HCR2016	26.0000	±30	±40 (-30 to +85°C)	±5	150	6	300
XRCGB27M000F3M00R0	HCR2016	27.0000	±30	±40 (-30 to +85°C)	±5	150	6	300
XRCGB27M120F3M00R0	HCR2016	27.1200	±30	±40 (-30 to +85°C)	±5	150	6	300
XRCGB30M000F3M00R0	HCR2016	30.0000	±30	±40 (-30 to +85°C)	±5	100	6	300
XRCGB31M250F3M00R0	HCR2016	31.2500	±30	±40 (-30 to +85°C)	±5	100	6	300
XRCGB32M000F3M00R0	HCR2016	32.0000	±30	±40 (-30 to +85°C)	±5	100	6	300
XRCGB33M868F4M00R0	HCR2016	33.8688	±45	±40 (-30 to +85°C)	±5	100	6	300
XRCGB38M400F4M00R0	HCR2016	38.4000	±45	±40 (-30 to +85°C)	±5	100	6	300

* Equivalent Series Resistance

Continued from the preceding page. ↘

1

Part Number	Type	Frequency (MHz)	Frequency Tolerance (ppm max.) [at 25°C±3°C]	Frequency Shift by Temperature (ppm max.) [Standard Condition: +25°C]	Frequency Aging (ppm max./Year)	ESR* (Ωmax.)	Load Capacitance (pF)	Drive Level (μW max.)
XRCGB40M000F4M00R0	HCR2016	40.0000	±45	±40 (-30 to +85°C)	±5	100	6	300
XRCGB48M000F4M00R0	HCR2016	48.0000	±45	±40 (-30 to +85°C)	±5	100	6	300
XRCGB50M000F4M00R0	HCR2016	50.0000	±45	±40 (-30 to +85°C)	±5	65	6	300
XRCPB24M000F3M00R0	HCR2016	24.0000	±30	±40 (-30 to +85°C)	±5	150	6	300
XRCPB24M576F3M00R0	HCR2016	24.5760	±30	±40 (-30 to +85°C)	±5	150	6	300
XRCPB25M000F3M00R0	HCR2016	25.0000	±30	±40 (-30 to +85°C)	±5	150	6	300
XRCPB26M000F3M00R0	HCR2016	26.0000	±30	±40 (-30 to +85°C)	±5	150	6	300
XRCPB27M000F3M00R0	HCR2016	27.0000	±30	±40 (-30 to +85°C)	±5	150	6	300
XRCPB27M120F3M00R0	HCR2016	27.1200	±30	±40 (-30 to +85°C)	±5	150	6	300
XRCPB30M000F3M00R0	HCR2016	30.0000	±30	±40 (-30 to +85°C)	±5	100	6	300
XRCPB31M250F3M00R0	HCR2016	31.2500	±30	±40 (-30 to +85°C)	±5	100	6	300
XRCPB32M000F3M00R0	HCR2016	32.0000	±30	±40 (-30 to +85°C)	±5	100	6	300
XRCPB33M868F4M00R0	HCR2016	33.8688	±45	±40 (-30 to +85°C)	±5	100	6	300
XRCPB40M000F4M00R0	HCR2016	40.0000	±45	±40 (-30 to +85°C)	±5	100	6	300
XRCPB48M000F4M00R0	HCR2016	48.0000	±45	±40 (-30 to +85°C)	±5	100	6	300
XRCPB50M000F4M00R0	HCR2016	50.0000	±45	±40 (-30 to +85°C)	±5	65	6	300

* Equivalent Series Resistance

<XRCGB_F_L/XRCPB_F_L>

Part Number	Type	Frequency (MHz)	Frequency Tolerance (ppm max.) [at 25°C±3°C]	Frequency Shift by Temperature (ppm max.) [Standard Condition: +25°C]	Frequency Aging (ppm max./Year)	ESR* (Ωmax.)	Load Capacitance (pF)	Drive Level (μW max.)
XRCGB24M000F0L00R0	HCR2016	24.0000	±100	±50 (-30 to +85°C)	±5	150	6	300
XRCGB24M576F0L00R0	HCR2016	24.5760	±100	±50 (-30 to +85°C)	±5	150	6	300
XRCGB25M000F0L00R0	HCR2016	25.0000	±100	±50 (-30 to +85°C)	±5	150	6	300
XRCGB26M000F0L00R0	HCR2016	26.0000	±100	±50 (-30 to +85°C)	±5	150	6	300
XRCGB27M000F0L00R0	HCR2016	27.0000	±100	±50 (-30 to +85°C)	±5	150	6	300
XRCGB27M120F0L00R0	HCR2016	27.1200	±100	±50 (-30 to +85°C)	±5	150	6	300
XRCGB30M000F0L00R0	HCR2016	30.0000	±100	±50 (-30 to +85°C)	±5	100	6	300
XRCGB31M250F0L00R0	HCR2016	31.2500	±100	±50 (-30 to +85°C)	±5	100	6	300
XRCGB32M000F0L00R0	HCR2016	32.0000	±100	±50 (-30 to +85°C)	±5	100	6	300
XRCGB33M868F0L00R0	HCR2016	33.8688	±100	±50 (-30 to +85°C)	±5	100	6	300
XRCGB38M400F0L00R0	HCR2016	38.4000	±100	±50 (-30 to +85°C)	±5	100	6	300
XRCGB40M000F0L00R0	HCR2016	40.0000	±100	±50 (-30 to +85°C)	±5	100	6	300
XRCGB48M000F0L00R0	HCR2016	48.0000	±100	±50 (-30 to +85°C)	±5	100	6	300
XRCGB50M000F0L00R0	HCR2016	50.0000	±100	±50 (-30 to +85°C)	±5	100	6	300
XRCPB24M000F0L00R0	HCR2016	24.0000	±100	±50 (-30 to +85°C)	±5	150	6	300
XRCPB24M576F0L00R0	HCR2016	24.5760	±100	±50 (-30 to +85°C)	±5	150	6	300
XRCPB25M000F0L00R0	HCR2016	25.0000	±100	±50 (-30 to +85°C)	±5	150	6	300
XRCPB26M000F0L00R0	HCR2016	26.0000	±100	±50 (-30 to +85°C)	±5	150	6	300
XRCPB27M000F0L00R0	HCR2016	27.0000	±100	±50 (-30 to +85°C)	±5	150	6	300
XRCPB27M120F0L00R0	HCR2016	27.1200	±100	±50 (-30 to +85°C)	±5	150	6	300
XRCPB30M000F0L00R0	HCR2016	30.0000	±100	±50 (-30 to +85°C)	±5	100	6	300
XRCPB31M250F0L00R0	HCR2016	31.2500	±100	±50 (-30 to +85°C)	±5	100	6	300
XRCPB32M000F0L00R0	HCR2016	32.0000	±100	±50 (-30 to +85°C)	±5	100	6	300
XRCPB33M868F0L00R0	HCR2016	33.8688	±100	±50 (-30 to +85°C)	±5	100	6	300
XRCPB40M000F0L00R0	HCR2016	40.0000	±100	±50 (-30 to +85°C)	±5	100	6	300
XRCPB48M000F0L00R0	HCR2016	48.0000	±100	±50 (-30 to +85°C)	±5	100	6	300
XRCPB50M000F0L00R0	HCR2016	50.0000	±100	±50 (-30 to +85°C)	±5	100	6	300

* Equivalent Series Resistance

<XRCHA_F_L>

Part Number	Type	Frequency (MHz)	Frequency Tolerance (ppm max.) [at 25°C±3°C]	Frequency Shift by Temperature (ppm max.) [Standard Condition: +25°C]	Frequency Aging (ppm max./Year)	ESR* (Ωmax.)	Load Capacitance (pF)	Drive Level (μW max.)
XRCHA16M000F0L01R0	HCR2520	16.0000	±100	±100 (-30 to +85°C)	±5	100	8	300
XRCHA20M000F0L01R0	HCR2520	20.0000	±100	±100 (-30 to +85°C)	±5	80	8	300

* Equivalent Series Resistance

6

Standard Land Pattern Dimensions

XRCGB_F_H/S/P/M/L, XRCPB_F_P/M/L
(HCR2016)

(Recommended Land Pattern)

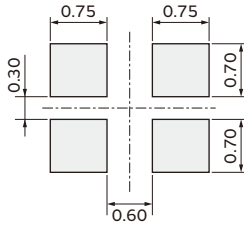

(in mm)

XRCHA_F_L
(HCR2520)

(Recommended Land Pattern)

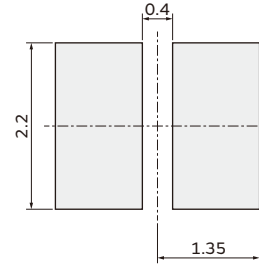

(in mm)

Notice -Crystal Units for Consumer and Industrial-

1

<XRCGB_F_H/S/P/M/L, XRCPB_F_P/M/L, XRCHA_F_L> Notice (Soldering and Mounting)

1.1. Soldering Condition

(1) Reflow

Please mount components on a circuit board by the reflow soldering.

Flux: Please use rosin based flux; but do not use water soluble flux.

Solder: Please use solder (Sn-3.0Ag-0.5Cu) under the following condition.

Standard thickness of soldering paste: 0.10 to 0.15mm

	Condition	
Pre-heating	150 to 180°C	60 to 120 sec.
Heating	220°C min.	30 to 60 sec.
Peak Temperature	245°C min. 260°C max. 5 sec. max.	

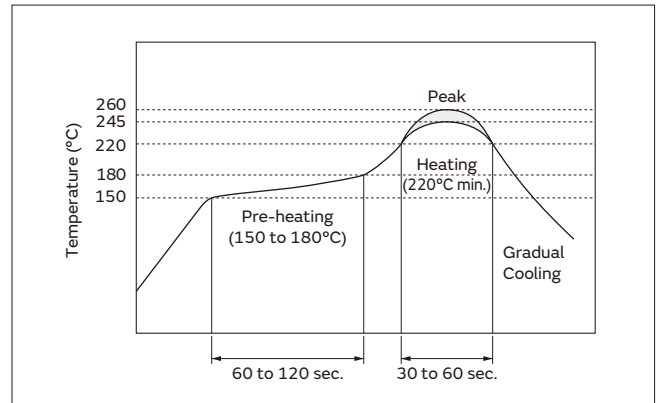

(2) Soldering Iron

If compelled to mount the component by using a soldering iron, please do not directly touch the component with the soldering iron. The component terminals or electrical characteristics may be damaged if excessive thermal stress is applied. Please keep solder away from the metal cap (Lid) portion.

	Condition
Pre-heating	150°C 60 sec.
Heating of the Soldering Iron	350°C max.
Watt	30W max.
Shape of the Soldering Iron	ø3mm max.
Soldering Time	5 sec. max.
Solder	Sn-3.0Ag-0.5Cu

1.2. Optimum Solder Amount for Soldering

Please keep the solder volume below the height of the substrate. When exceeding the substrate, the damage of sealing part between the metal cap and the substrate may occur.

2. Wash

The component cannot withstand washing.

3. Notice for Mounting

The component is recommended with placement machines employing optical placement capabilities. The component might be damaged by mechanical force depending on placement machine and condition. Make sure that you have evaluated by using placement machines before going into mass production. Do not use placement machines employing mechanical positioning. Please contact Murata for details beforehand.

Continued on the following page. ↗

8

Notice -Crystal Units for Consumer and Industrial-

Continued from the preceding page. ↘

Notice (Storage and Operating Condition)

1. Product Storage Condition

Please store the products in room where the temperature/humidity is stable. And avoid such places where there are large temperature changes. Please store the products under the following conditions:

Temperature: -10 to + 40 degrees C

Humidity: 15 to 85% R.H.

2. Expire Date on Storage

Expiration date (shelf life) of the products is 6 months after delivery under the conditions of an unopened package. Please use the products within 6 months after delivery. If you store the products for a long time (more than 6 months), use carefully because the products may be degraded in solderability and/or rusty.

Please confirm solderability and characteristics for the products regularly.

3. Notice on Product Storage

(1) Please do not store the products in a chemical atmosphere (Acids, Alkali, Bases, Organic gas, Sulfides and so on), because the characteristics may be reduced in quality, and/or be degraded in solderability due to the storage in a chemical atmosphere.

(2) Please do not put the products directly on the floor without anything under them to avoid damp places and/or dusty places.

(3) Please do not store the products in the places under direct sunlight, heat and vibration.

(4) Please use the products immediately after the package is opened, because the characteristics may be reduced in quality, and/or be degraded in solderability due to storage under poor conditions.

(5) Please do not drop the products to avoid cracking the crystal element.

4. Other

Conformal coating or washing of the component is not acceptable.

Please be sure to consult with our sales representative or engineer prior to using the products.

Notice (Rating)

The component may be damaged if excess mechanical stress is applied.

Notice (Handling)

1. Please confirm circuit the conditions on your set, because irregular or stop oscillation may occur under unmatched circuit conditions.

2. Be sure to provide an appropriate fail-safe function on your product to prevent a second damage that may be caused by the abnormal function or the failure of our product.

3. Please do not use these products in the following applications in transportation equipment: vehicles, trains, ships, etc.

(example: engine control, brake control, steering control, body control.)

1 Packaging -Crystal Units for Consumer and Industrial-

Dimensions of Taping

**XRCGB_F_H/S/P/M/L
 (HCR2016)**

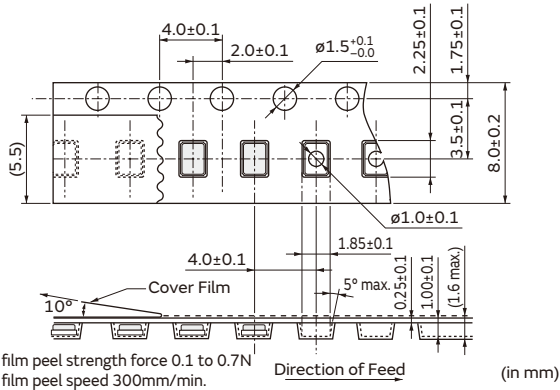

**XRCPB_F_P/M/L
 (HCR2016)**

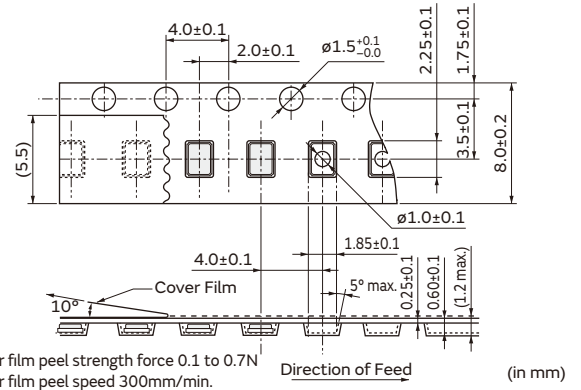

**XRCHA_F_L
 (HCR2520)**

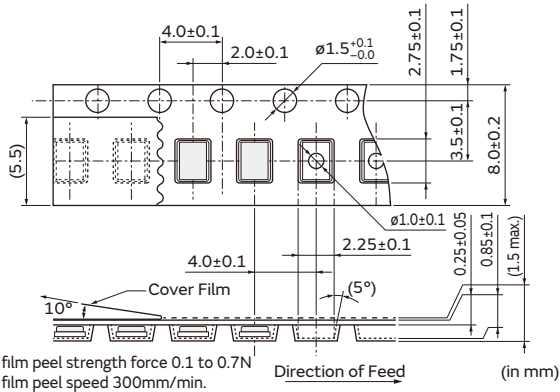

Minimum Quantity/Dimensions of Reel

Plastic Tape ø180mm	Plastic Tape ø330mm
3,000	9,000

(pcs.)

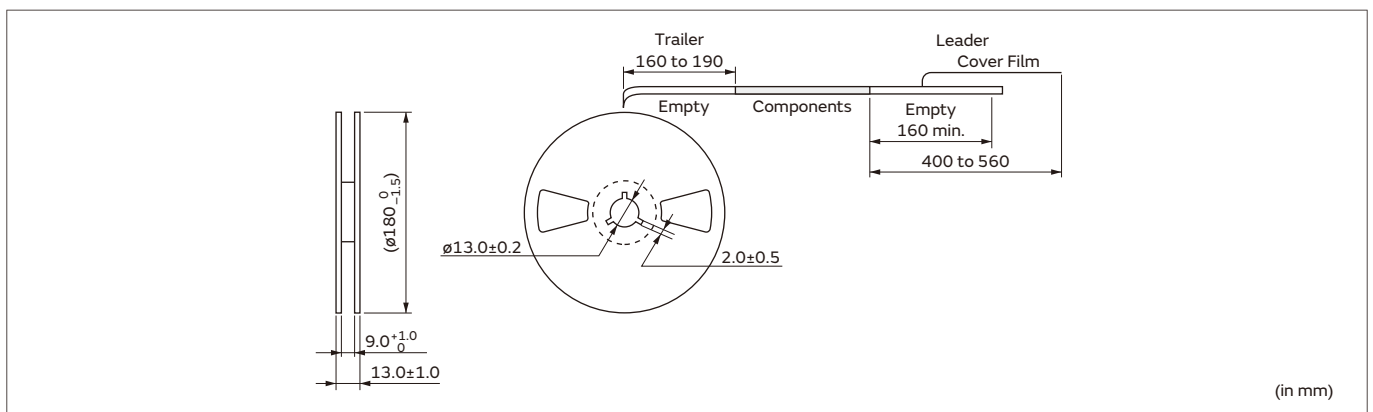

Crystal Units

for Automotive



These crystal units for automotive feature a small package and highly accurate frequency, based on Murata's excellent package technology and high grade quartz crystal elements.

Features

1. The series has high reliability and is available for a wide temperature range.
2. The crystal units are extremely small, contributing to a reduction in the mounting area.
3. The series complies to RoHS and ELV directives, being lead-free (phase 3).
4. The series complies to AEC-Q200.

Applications

1. Power Train (ex. Engine/Transmission management ECU)
2. ADAS (ex. Camera for driver assist, Image processing, Emergency Brake Assist ECU)
3. Chassis, Safety applications, etc.
4. Car multimedia equipment.

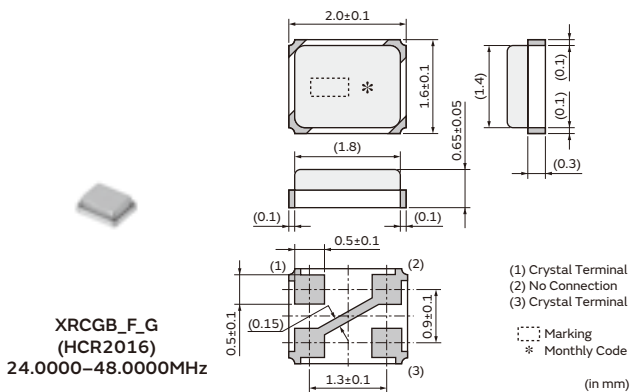
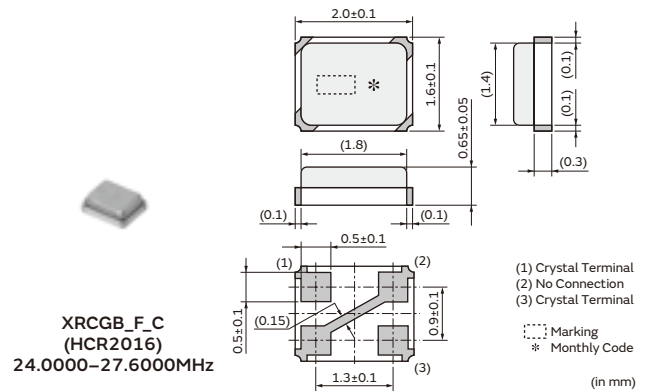
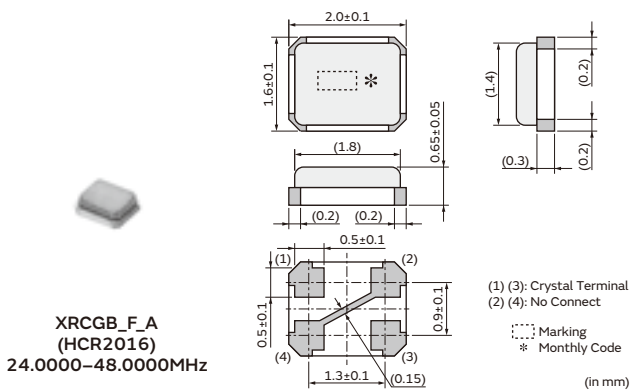
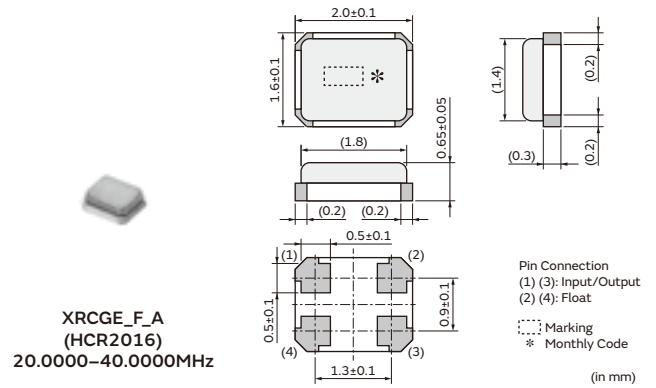
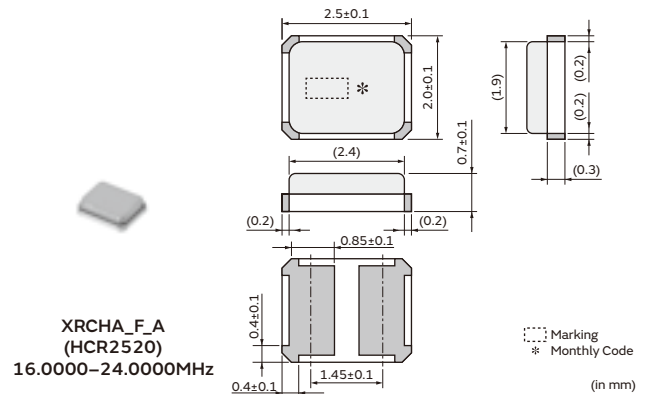

Series

Series	Type	Package	Frequency (MHz)	Frequency Tolerance (ppm max.) [at 25°C±3°C]	Frequency Shift by Temperature (ppm max.) [Standard Condition: +25°C]	Frequency Aging (ppm max./Year)	Operating Temperature Range (°C)	Applications
XRCHA_F_A	HCR2520	Resin	16.0000 to 24.0000	±100	±100	±5	-40 to +125*	ADAS, Power Train, Chassis, Safety
XRCGE_F_A	HCR2016		20.0000 to 23.9999	±30	±40	±5	-40 to +125	Microcomputer for Automotive
XRCGB_F_A			24.5454 to 27.6000	±15	±35	±10/10Years	-40 to +125	ADAS, Safety
			40.0000	±30	±45	±20/15Years	-40 to +125	ADAS, Safety
XRCGB_F_C			24.0000 to 48.0000	±30/±50	±35/±65	±2	-40 to +125	ADAS, Power Train, Chassis, Safety, Security
XRCGB_F_G			24.0000 to 27.6000	±20	±20	±2	-30 to +85	Comfort, Security, Infotainment
			24.0000 to 48.0000	±30/±45/±100	±50	±5	-40 to +85	Car Multimedia

* +150°C is available.

Part Number List

<XRCHA_F_A (For Automotive)>

Part Number	Type	Frequency (MHz)	Frequency Tolerance (ppm max.) [at 25°C±3°C]	Frequency Shift by Temperature (ppm max.) [Standard Condition: +25°C]	Frequency Aging (ppm max./Year)	ESR* (Ωmax.)	Load Capacitance (pF)	Drive Level (μW max.)
XRCHA16M000FOA01R0	HCR2520	16.0000	±100	±100 (-40 to +125°C)	±5	100	8	300
XRCHA16M000FOA11R0	HCR2520	16.0000	±100	±100 (-40 to +125°C)	±5	100	8	600
XRCHA16M000FOA12R0	HCR2520	16.0000	±100	±100 (-40 to +150°C)	±5	100	8	300
XRCHA16M000FOA13R0	HCR2520	16.0000	±100	±100 (-40 to +150°C)	±5	100	8	600
XRCHA20M000FOA01R0	HCR2520	20.0000	±100	±100 (-40 to +125°C)	±5	80	8	300
XRCHA20M000FOA11R0	HCR2520	20.0000	±100	±100 (-40 to +125°C)	±5	80	8	600
XRCHA20M000FOA12R0	HCR2520	20.0000	±100	±100 (-40 to +150°C)	±5	80	8	300
XRCHA20M000FOA13R0	HCR2520	20.0000	±100	±100 (-40 to +150°C)	±5	80	8	600
XRCHA24M000FOA01R0	HCR2520	24.0000	±100	±100 (-40 to +125°C)	±5	80	8	300
XRCHA24M000FOA11R0	HCR2520	24.0000	±100	±100 (-40 to +125°C)	±5	80	8	600
XRCHA24M000FOA12R0	HCR2520	24.0000	±100	±100 (-40 to +150°C)	±5	80	8	300
XRCHA24M000FOA13R0	HCR2520	24.0000	±100	±100 (-40 to +150°C)	±5	80	8	600

* Equivalent Series Resistance

<XRCGE_F_A (For Automotive)>

Part Number	Type	Frequency (MHz)	Frequency Tolerance (ppm max.) [at 25°C±3°C]	Frequency Shift by Temperature (ppm max.) [Standard Condition: +25°C]	Frequency Aging (ppm max./Year)	ESR* (Ωmax.)	Load Capacitance (pF)	Drive Level (μW max.)
XRCGE20M000F3A1BR0	HCR2016	20.0000	±30	±45 (-40 to +125°C)	±5	150	8	300
XRCGE24M545FBA1AR0	HCR2016	24.5454	±15	±35 (-40 to +125°C)	±10/10Years	100	6	300
XRCGE25M000FBA1AR0	HCR2016	25.0000	±15	±35 (-40 to +125°C)	±10/10Years	100	6	300
XRCGE26M000FBA1AR0	HCR2016	26.0000	±15	±35 (-40 to +125°C)	±10/10Years	80	6	300
XRCGE27M000FBA1AR0	HCR2016	27.0000	±15	±35 (-40 to +125°C)	±10/10Years	80	6	300
XRCGE27M600FBA1AR0	HCR2016	27.6000	±15	±35 (-40 to +125°C)	±10/10Years	80	6	300
XRCGE24M000FBA1AR0	HCR2016	24.0000	±15	±35 (-40 to +125°C)	±10/10Years	120	6	300
XRCGE40M000F3A1AR0	HCR2016	40.0000	±30	±45 (-40 to +125°C)	±20/15Years	70	6	300

* Equivalent Series Resistance

<XRCGB_F_A (For Automotive)>

Part Number	Type	Frequency (MHz)	Frequency Tolerance (ppm max.) [at 25°C±3°C]	Frequency Shift by Temperature (ppm max.) [Standard Condition: +25°C]	Frequency Aging (ppm max./Year)	ESR* (Ωmax.)	Load Capacitance (pF)	Drive Level (μW max.)
XRCGB24M000F3A00R0	HCR2016	24.0000	±30	±35 (-40 to +125°C)	±2	120	6	300
XRCGB24M305F3A00R0	HCR2016	24.3050	±30	±35 (-40 to +125°C)	±2	110	6	300
XRCGB25M000F3A00R0	HCR2016	25.0000	±30	±35 (-40 to +125°C)	±2	100	6	300

* Equivalent Series Resistance

Continued on the following page. ↗

Continued from the preceding page. ↘

Part Number	Type	Frequency (MHz)	Frequency Tolerance (ppm max.) [at 25°C±3°C]	Frequency Shift by Temperature (ppm max.) [Standard Condition: +25°C]	Frequency Aging (ppm max./Year)	ESR* (Ωmax.)	Load Capacitance (pF)	Drive Level (μW max.)
XRCGB26M000F3A00R0	HCR2016	26.0000	±30	±35 (-40 to +125°C)	±2	80	6	300
XRCGB27M000F3A00R0	HCR2016	27.0000	±30	±35 (-40 to +125°C)	±2	80	6	300
XRCGB27M120F3A00R0	HCR2016	27.1200	±30	±35 (-40 to +125°C)	±2	80	6	300
XRCGB30M000F5A00R0	HCR2016	30.0000	±50	±65 (-40 to +125°C)	±2	70	6	300
XRCGB40M000F5A00R0	HCR2016	40.0000	±50	±65 (-40 to +125°C)	±2	70	6	300
XRCGB48M000F5A00R0	HCR2016	48.0000	±50	±65 (-40 to +125°C)	±2	60	6	300

* Equivalent Series Resistance

<XRCGB_F_C (For Automotive)>

Part Number	Type	Frequency (MHz)	Frequency Tolerance (ppm max.) [at 25°C±3°C]	Frequency Shift by Temperature (ppm max.) [Standard Condition: +25°C]	Frequency Aging (ppm max./Year)	ESR* (Ωmax.)	Load Capacitance (pF)	Drive Level (μW max.)
XRCGB24M000F2C00R0	HCR2016	24.0000	±20	±50 (-40 to +105°C)	±2	120	6	300
XRCGB27M600F2C00R0	HCR2016	27.6000	±20	±20 (-30 to +85°C)	±2	80	6	300

* Equivalent Series Resistance

<XRCGB_F_G (For Car Multimedia)>

Part Number	Type	Frequency (MHz)	Frequency Tolerance (ppm max.) [at 25°C±3°C]	Frequency Shift by Temperature (ppm max.) [Standard Condition: +25°C]	Frequency Aging (ppm max./Year)	ESR* (Ωmax.)	Load Capacitance (pF)	Drive Level (μW max.)
XRCGB24M000F0G00R0	HCR2016	24.0000	±100	±50 (-40 to +85°C)	±5	150	6	300
XRCGB24M000F3G00R0	HCR2016	24.0000	±30	±50 (-40 to +85°C)	±5	150	6	300
XRCGB24M576F0G00R0	HCR2016	24.5760	±100	±50 (-40 to +85°C)	±5	150	6	300
XRCGB24M576F3G00R0	HCR2016	24.5760	±30	±50 (-40 to +85°C)	±5	150	6	300
XRCGB25M000F0G00R0	HCR2016	25.0000	±100	±50 (-40 to +85°C)	±5	150	6	300
XRCGB25M000F3G00R0	HCR2016	25.0000	±30	±50 (-40 to +85°C)	±5	150	6	300
XRCGB26M000F0G00R0	HCR2016	26.0000	±100	±50 (-40 to +85°C)	±5	150	6	300
XRCGB26M000F3G00R0	HCR2016	26.0000	±30	±50 (-40 to +85°C)	±5	150	6	300
XRCGB27M000F0G00R0	HCR2016	27.0000	±100	±50 (-40 to +85°C)	±5	150	6	300
XRCGB27M000F3G00R0	HCR2016	27.0000	±30	±50 (-40 to +85°C)	±5	150	6	300
XRCGB27M120F3G00R0	HCR2016	27.1200	±30	±50 (-40 to +85°C)	±5	150	6	300
XRCGB30M000F0G00R0	HCR2016	30.0000	±100	±50 (-40 to +85°C)	±5	100	6	300
XRCGB30M000F3G00R0	HCR2016	30.0000	±30	±50 (-40 to +85°C)	±5	100	6	300
XRCGB33M868F0G00R0	HCR2016	33.8688	±100	±50 (-40 to +85°C)	±5	100	6	300
XRCGB33M868F4G00R0	HCR2016	33.8688	±45	±50 (-40 to +85°C)	±5	100	6	300
XRCGB40M000F0G00R0	HCR2016	40.0000	±100	±50 (-40 to +85°C)	±5	100	6	300
XRCGB40M000F4G00R0	HCR2016	40.0000	±45	±50 (-40 to +85°C)	±5	100	6	300
XRCGB48M000F0G00R0	HCR2016	48.0000	±100	±50 (-40 to +85°C)	±5	100	6	300
XRCGB48M000F4G00R0	HCR2016	48.0000	±45	±50 (-40 to +85°C)	±5	100	6	300

* Equivalent Series Resistance

Standard Land Pattern Dimensions

XRCHA_F_A
 (HCR2520)

(Recommended Land Pattern)

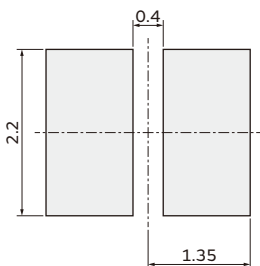

(in mm)

XRCGE_F_A, XRCGB_F_A/C/G
 (HCR2016)

(Recommended Land Pattern)

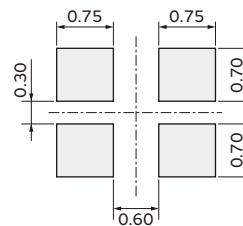

(in mm)

Notice -Crystal Units for Automotive-

Notice (Soldering and Mounting)

1.1. Soldering Condition

(1) Reflow

Please mount components on a circuit board by the reflow soldering.

Flux: Please use rosin based flux; but do not use water soluble flux.

Solder: Please use solder (Sn-3.0Ag-0.5Cu) under the following condition.

Standard thickness of soldering paste: 0.10 to 0.15mm

	Condition	
Pre-heating	150 to 180°C	60 to 120 sec.
Heating	220°C min.	30 to 60 sec.
Peak Temperature	245°C min. 260°C max. 5 sec. max.	

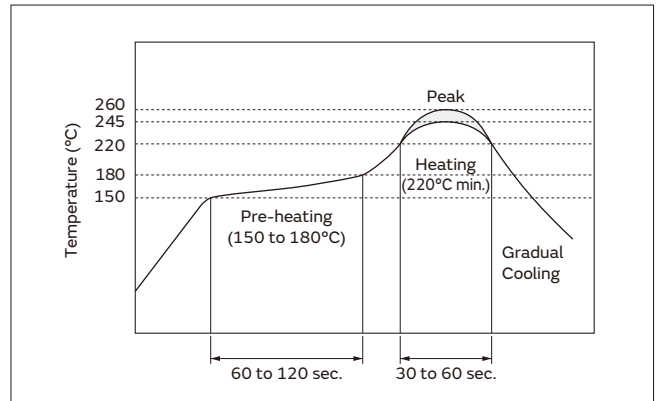

(2) Soldering Iron

If compelled to mount the component by using a soldering iron, please do not directly touch the component with the soldering iron. The component terminals or electrical characteristics may be damaged if excessive thermal stress is applied.

	Condition
Pre-heating	150°C 60 sec.
Heating of the Soldering Iron	350°C max.
Watt	30W max.
Shape of the Soldering Iron	ø3mm max.
Soldering Time	5 sec. max.
Solder	Sn-3.0Ag-0.5Cu

1.2. Optimum Solder Amount for Soldering

Please keep the solder volume below the height of the substrate. When exceeding the substrate, damage of sealing part between the metal cap and the substrate may occur.

2. Wash

The component cannot withstand washing.

3. Notice for Mounting

The component is recommended with placement machines employing optical placement capabilities. The component might be damaged by mechanical force depending on placement machine and condition. Make sure that you have evaluated by using placement machines before going into mass production. Do not use placement machines employing mechanical positioning. Please contact Murata for details beforehand.

Continued on the following page. ↗

Notice -Crystal Units for Automotive-

Continued from the preceding page. ↘

Notice (Storage and Operating Condition)

1. Product Storage Condition

Please store the products in room where the temperature/humidity is stable. And avoid such places where there are large temperature changes. Please store the products under the following conditions:

Temperature: -10 to + 40 degrees C

Humidity: 15 to 85% R.H.

2. Expire Date on Storage

Expiration date (shelf life) of the products is 6 months after delivery under the conditions of an unopened package. Please use the products within 6 months after delivery. If you store the products for a long time (more than 6 months), use carefully because the products may be degraded in solderability and/or rusty.

Please confirm solderability and characteristics for the products regularly.

3. Notice on Product Storage

(1) Please do not store the products in a chemical atmosphere (Acids, Alkali, Bases, Organic gas, Sulfides and so on), because the characteristics may be reduced in quality, and/or be degraded in solderability due to the storage in a chemical atmosphere.

(2) Please do not put the products directly on the floor without anything under them to avoid damp places and/or dusty places.

(3) Please do not store the products in the places under direct sunlight, heat and vibration.

(4) Please use the products immediately after the package is opened, because the characteristics may be reduced in quality, and/or be degraded in solderability due to storage under poor conditions.

(5) Please do not drop the products to avoid cracking the crystal element.

4. Other

Conformal coating or washing of the component is not acceptable because it is not hermetically sealed.

Please be sure to consult with our sales representative or engineer whenever and prior to using the products.

Notice (Rating)

The component may be damaged if excess mechanical stress is applied.

Notice (Handling)

1. Irregular or stopped oscillation may occur under unmatched circuit conditions.

Please design your oscillation circuit to get 5 times or more of a negative resistance against the maximum value of the Equivalent Series Resistance, that is specified in order.

2. Be sure to provide an appropriate fail-safe function on your product to prevent a second damage that may be caused by the abnormal function or the failure of our product.

Packaging -Crystal Units for Automotive-

Dimensions of Taping

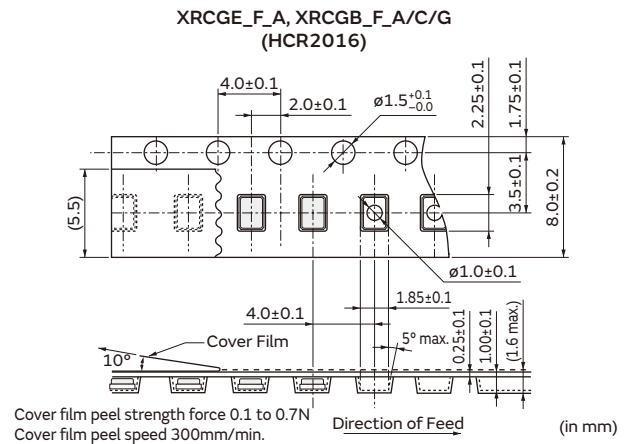
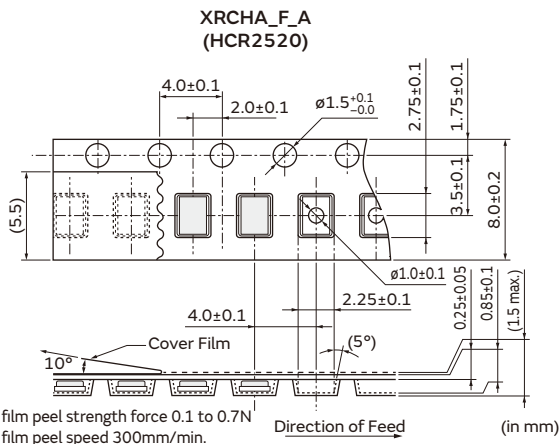

Minimum Quantity/Dimensions of Reel

Plastic Tape $\phi 180$ mm	Plastic Tape $\phi 330$ mm
3,000	9,000

(pcs.)

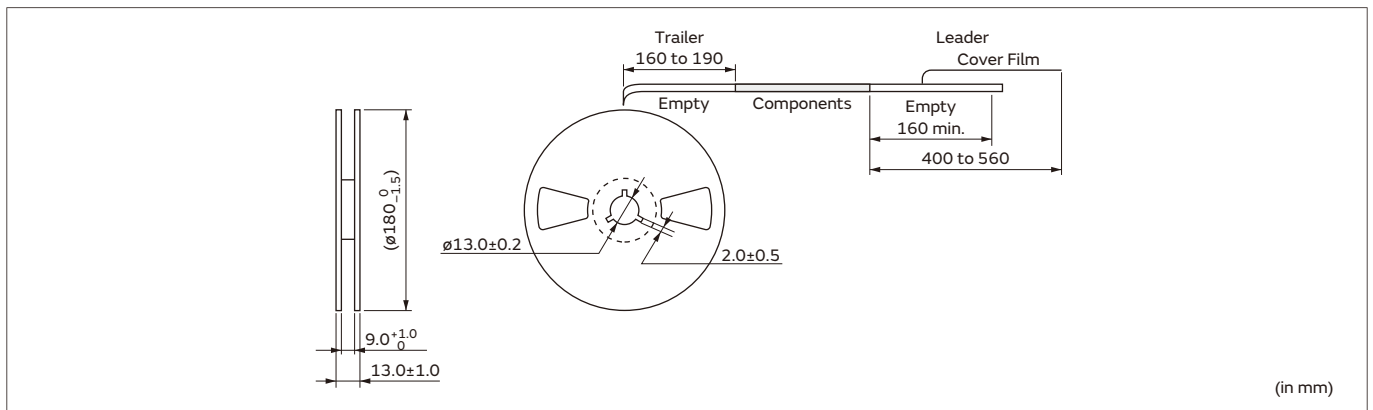

Measuring Circuit of Crystal Units

Measuring Circuit 1

1. Frequency Measuring Method

The load resonance frequency (Lower frequency of the two given when the electrical impedance of the component becomes resistant near its resonance point) is measured by network analyzer (KEYSIGHT E5100A or the equivalent) and the circuit in Figure 1. DUT is shown in Figure 2, and the value of Cs refers to the load capacitance value in specifications.

2. Equivalent Series Resistance

The equivalent series resistance (ESR) is measured by network analyzer (KEYSIGHT E5100A or equivalent) and the circuit in Figure 1. DUT is shown in Figure 3.

3. Measuring Condition

Standard conditions for measurement shall be $+25\pm 3^{\circ}\text{C}$ temperature and humidity of 45 to 85%R.H.

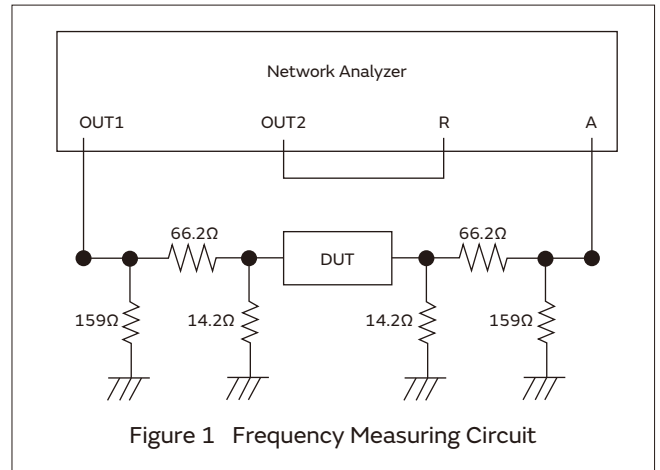

Figure 1 Frequency Measuring Circuit

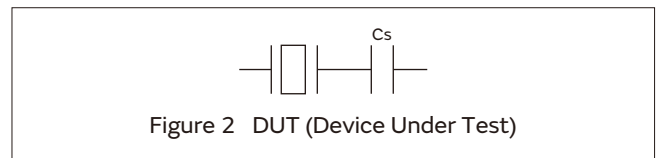

Figure 2 DUT (Device Under Test)

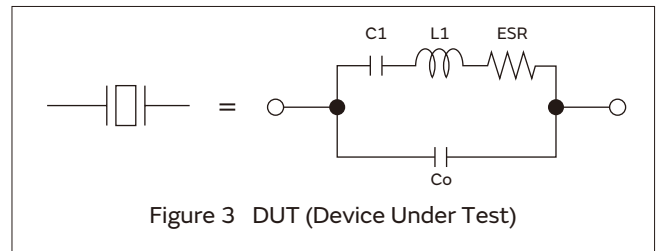

Figure 3 DUT (Device Under Test)

Measuring Circuit 2

1. Frequency Measuring Method

The load resonance frequency is measured by network analyzer (S&A 250B or the equivalent) and the circuit in Figure 1. Measured frequency may be changed by using different measurement equipment.

2. Equivalent Series Resistance

The equivalent series resistance (ESR) is measured by network analyzer (S&A 250B or equivalent) and the circuit in Figure 1. DUT is shown in Figure 2.

3. Measuring Condition

Standard conditions for measurement shall be $+30\pm 0.5^{\circ}\text{C}$ and 25 to 75%R.H.

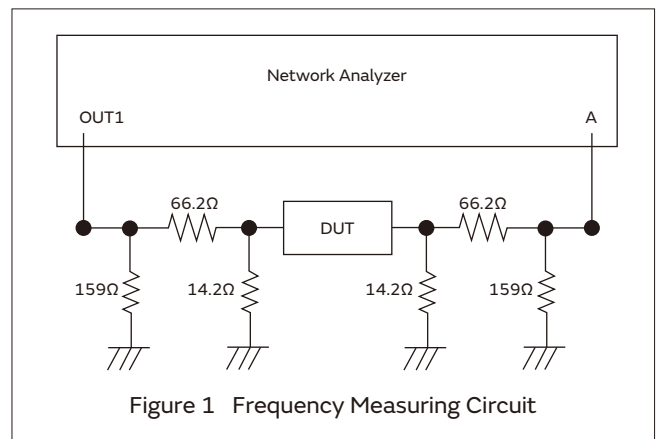

Figure 1 Frequency Measuring Circuit

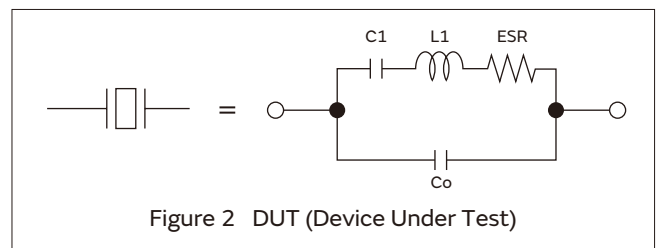

Figure 2 DUT (Device Under Test)

Global Locations

For details please visit www.murata.com



⚠ Note

1 Export Control

For customers outside Japan:

No Murata products should be used or sold, through any channels, for use in the design, development, production, utilization, maintenance or operation of, or otherwise contribution to (1) any weapons (Weapons of Mass Destruction [nuclear, chemical or biological weapons or missiles] or conventional weapons) or (2) goods or systems specially designed or intended for military end-use or utilization by military end-users.

For customers in Japan:

For products which are controlled items subject to the "Foreign Exchange and Foreign Trade Law" of Japan, the export license specified by the law is required for export.

2 Please contact our sales representatives or product engineers before using the products in this catalog for the applications listed below, which require especially high reliability for the prevention of defects which might directly damage a third party's life, body or property, or when one of our products is intended for use in applications other than those specified in this catalog.

- ① Aircraft equipment
- ② Aerospace equipment
- ③ Undersea equipment
- ④ Power plant equipment
- ⑤ Medical equipment
- ⑥ Transportation equipment (vehicles, trains, ships, etc.)
- ⑦ Traffic signal equipment
- ⑧ Disaster prevention / crime prevention equipment
- ⑨ Data-processing equipment
- ⑩ Application of similar complexity and/or reliability requirements to the applications listed above

3 Product specifications in this catalog are as of December 2020. They are subject to change or our products in it may be discontinued without advance notice. Please check with our sales representatives or product engineers before ordering. If there are any questions, please contact our sales representatives or product engineers.

4 Please read rating and ⚠CAUTION (for storage, operating, rating, soldering, mounting and handling) in this catalog to prevent smoking and/or burning, etc.

5 This catalog has only typical specifications. Therefore, please approve our product specifications or transact the approval sheet for product specifications before ordering.

6 Please note that unless otherwise specified, we shall assume no responsibility whatsoever for any conflict or dispute that may occur in connection with the effect of our and/or a third party's intellectual property rights and other related rights in consideration of your use of our products and/or information described or contained in our catalogs. In this connection, no representation shall be made to the effect that any third parties are authorized to use the rights mentioned above under licenses without our consent.

7 No ozone depleting substances (ODS) under the Montreal Protocol are used in our manufacturing process.

Murata Manufacturing Co., Ltd.

www.murata.com

muRata
INNOVATOR IN ELECTRONICS

单击下面可查看定价，库存，交付和生命周期等信息

[>>Murata\(村田\)](#)