



### PRODUCT OVERVIEW

The D1U4-W-1600-54-HBxC is a 1600W power factor corrected (PFC) front end power module intended for hot swap redundant systems. There is a main output of 54VDC (floating with respect to chassis ground) and a 12VDC Standby/bias output (that is present whenever the incoming AC source is applied).

The form factor is suitable for 1RU chassis enclosures and is designed to deliver reliable bulk DC power to servers, workstations, storage systems, PoE switches or any 54VDC distributed power architecture requiring high power density.

The high efficiency design supports speed controlled dual DC fans in a thermally optimized package that is self-protecting and able to auto recover from over-current and over-temperature events. Visual status information is provided via front panel mounted LED indicators in addition to hardware logic signals and a PMBus™ management interface.

### ORDERING GUIDE

Model Number	Power Output High Line AC	Power Output Low Line AC	Main Output	Standby Output	Airflow
D1U4-W-1600-54-HB4C	1600W	1200W	54V	12V	Back to front
D1U4-W-1600-54-HB3C					Front to back

In Production  
To Be Discontinued \*

### FEATURES

- 1600W Output Power
- 1.6"(1U) x 14.0" x 4.0" (41.0mm x 355.6mm x 101.6mm)
- 54VDC Main; PoE compatible
- 12V SB Output
- PMBus™ Power Management Bus supported by dual redundant I2C interfaces.
- N+1 Redundancy Capable; hot swap (up to 8 modules in parallel)
- Active current sharing on 54VDC Main output; integral bidirectional MOSFET output isolation device
- Over-Voltage, Over-Current; Over-Temperature Protection
- Internal variable speed cooling fans
- 20ms full cycle hold up
- RoHS Compliant
- Two-year warranty

### INPUT CHARACTERISTICS

Parameter	Conditions	Min.	Typ.	Max.	Units
Input Voltage Operating Range		90	115/230	264	Vac
Input Frequency		47	50/60	63	Hz
Turn-on Input Voltage	Ramp Up	81		89	Vac
Turn-off Input Voltage	Ramp Down	70.5		78.0	Vac
Maximum Current @ VIN = 200Vac	1600W			10	Arms
Maximum Current @ VIN = 90Vac	1200W			15	Arms
Inrush Current	Cold start between 0 to 1ms			100	Apk
Power Factor	At 230Vac; FL	0.95			

### OUTPUT VOLTAGE CHARACTERISTICS

Output Voltage	Parameter	Conditions	Min.	Typ.	Max.	Units
54V	Voltage Set Point			54V		Vdc
	Line & Load Regulation		52.38		55.62	Vdc
	Output Current		0		30	A
	Ripple Voltage & Noise <sup>1</sup>	20MHz Bandwidth			540	mVp-p
	Load Capacitance		3800		24,000	µF
12V	Voltage Set Point			12		Vdc
	Line & Load Regulation		11.64		12.36	Vdc
	Output Current		0		2	A
	Ripple Voltage & Noise <sup>1</sup>	20MHz Bandwidth			33	mVp-p
	Load Capacitance				1530	µF

<sup>1</sup> Ripple and noise are measured with a parallel combination of a 0.1µF ceramic capacitor and 2 x 270µF OSCON capacitors on each of the power module outputs measurement nodes. See test set up diagram below.



Available now at  
[www.murata-ps.com/en/3d/acdc.html](http://www.murata-ps.com/en/3d/acdc.html)



### RIPPLE MEASUREMENT

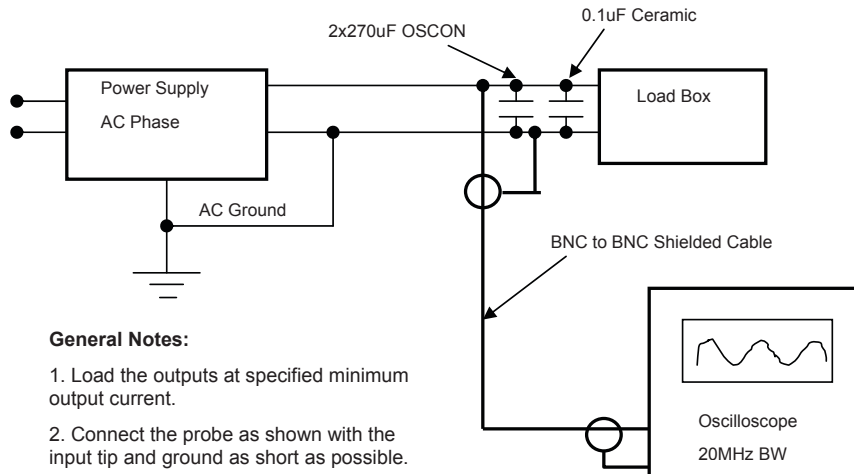

**General Notes:**

1. Load the outputs at specified minimum output current.
2. Connect the probe as shown with the input tip and ground as short as possible.
3. Take all measurements
4. Repeat the measurements with the outputs at specified maximum output current.

### OUTPUT CHARACTERISTICS

Parameter	Conditions	Min.	Typ.	Max.	Units
Remote Sense	Remote sense is not enabled on these variants due to the System Control feature and the relatively wide line & load regulation window.				
Efficiency	230Vac (excluding fan)		90		%
Output Rise (Monotonic)	10% to 95% rise time	Overshoot less than 10% for all outputs; no negative transition at turn off.			
Startup Time	AC Ramp Up		3		s
	PS_ON activation		250		ms
Transient Response	54VDC 50% step (50-100%; 100%-50%) load; 1A/μs		±2700		mV
	12VSB 1A/μs		±250		
Current Sharing Accuracy (up to 8 in parallel)	At 100% load			±10	%
Hot Swap Transients				5	%
Hold Up Time	100% load 230Vac nominal	20			ms

### ENVIRONMENTAL CHARACTERISTICS

Parameter	Conditions	Min.	Typ.	Max.	Units
Storage Temperature Range	Non-Condensing	-40		70	°C
Operating Temperature Range		0		50	
Operating Humidity	Non-Condensing	10		90	%
Storage Humidity		5		90	
Altitude		3000			M
Shock	Non-Operating			30	G
Operational Vibration	Operational, 0.5G; 5-500Hz				
MTBF	Telcordia SR-332 40°C	630			K Hours
Safety Approvals	CAN/CSA-C22.2 No.60950-1-07 Am 1:2011 ANSI/UL 60950-1-2011 IEC60950-1:2005 (2nd Ed)+A1:2009 and EN60950-1:2006/A11:2009/A1:2010/A12:2011 CQC GB4943,1-2011				
Input Fusing	Internal 20A/250V rated fast blow in AC line				
Weight				4.63/2.1	lbs/kg

PROTECTION CHARACTERISTICS						
Output Voltage	Parameter	Conditions	Min.	Typ.	Max.	Units
54V	Over-Temperature	Auto re-start	55		65	°C
	Over-Voltage	Latching	57		60	V
	Over-Current	Constant Current for 200ms followed by latch	33		39	A
12VSB	Over-Voltage	Latching	13.5		14.4	V
	Over-Current	Latching	2.2		2.6	A

ISOLATION CHARACTERISTICS					
Parameter	Conditions	Min.	Typ.	Max.	Units
Insulation Safety Rating / Test Voltage	Input to Output - Reinforced	3000			Vrms
	Input to Chassis - Basic	1500			Vrms
Isolation	Output to Chassis (Ground)	2250			Vdc
Grounding	<p>The Main 54VDC output shall be provided with isolation between the output and chassis ground. It shall be able to withstand the following tests:</p> <p>a) 1500VRMS at 50Hz to 60Hz for 60s. b) 2250 VDC for 60s.</p> <p>There shall be no insulation breakdown during the test as defined in sub clause 5.2.2 of IEC 60950-1:2001. The resistance after the test should be at least 2M ohms when measured at 500VDC.</p> <p>The VRTN should be isolated from the 12VSB Return and the power module shall support PoE Electrical Isolation Requirements.</p>				

STATUS INDICATORS AND CONTROL SIGNALS		
Status	Conditions	Description
LED Indicators	Off	No AC applied to any power module in host system
	Off	No AC applied to this power module only
	Blinking Green	AC Present & VSTANDBY "on"
	Green	54VDC and VSTANDBY "on" and "OK"
	Blinking Amber	Power Module Warning
	Amber	Power Module Failure
I <sup>2</sup> C and PMBus	<p>There is provision for the connection of dual I<sup>2</sup>C buses for redundancy. This enables two master devices to connect to single slave device(s) within the power module. The power module is provided with a PMBus Management Interface that provides status, measurement and control data.</p>	
SYS_CONTR	Host system control input that can be used to turn on/off the Main 54VDC Output.	

EMISSIONS AND IMMUNITY		
Characteristic	Standard	Compliance
Input Current Harmonics	IEC/EN 61000-3-2	Complies with Class A Limits
Voltage Fluctuation & Flicker	IEC/EN 61000-3-3	Complies
Conducted Emissions	FCC 47 CFR Part 15; CISPR 22; EN55022	Complies to Class A with 6dB margin
Radiated Emissions		Complies to Class A with 6dB margin
ESD Immunity	IEC/EN 61000-4-2;	4KV Contact discharge; Criteria A
		8KV Operational air discharge; Criteria A
		15KV non-operational air discharge, Criteria A
Radiated Field Immunity	IEC/EN 61000-4-3	Complies
Electrical Fast Transients/Burst Immunity	IEC/EN 61000-4-4	Complies
Surge Immunity	IEC/EN 61000-4-5	1KV/2KV; Criteria A performance
RF Conducted Immunity	IEC/EN 61000-4-6	3VAC, 80% AM, 1KHz; Criteria A performance
Magnetic Field Immunity	IEC/EN 61000-4-8	3A/m
Voltage Dips & Interruptions	IEC/EN 61000-4-11	Complies

### OUTPUT CONNECTOR AND SIGNAL SPECIFICATION

DC and Signal Connector: FCI # 51732-028-LF

P1	P2	P3	P4	P5	P6	x1	x2	x3	x4	x5	
V <sub>OUT</sub>	V <sub>OUT</sub>	V <sub>OUT</sub>	V <sub>RTN</sub>	V <sub>RTN</sub>	V <sub>RTN</sub>	AC_OK	P_GOOD	V_STBY	No User Connection	V_STBY RETURN	D
						PS_ON	V_STBY	V_STBY	V_STBY RETURN	V_STBY RETURN	C
						I_SHARE	SYS_CONTR	I <sup>2</sup> C DATA2	I <sup>2</sup> C CLOCK2	PS_PRESENT	B
						PS_KILL	V <sub>out</sub> SENSE+	V <sub>out</sub> SENSE-	I <sup>2</sup> C DATA1	I <sup>2</sup> C CLOCK1	A

Blade/ Pin Assignment	Signal Name	Description	Logic Level	Current
P1, P2, P3	VOUT	Main 54V Output Voltage		
P4, P5, P6	VRTN	Main 54V Output Voltage, Return		
A2	VOUT_SENSE +	Main 54V Output Voltage Sense +		
A3	VOUT_SENSE -	Main 54V Output Voltage Sense -		
C2, C3, D3	VSTBY	Standby Voltage Output		
C4, C5, D5	VSTBY Return	Standby Voltage Output, Return		
B1	I_SHARE	Analogue active current share bus	0V to 8V	-4mA/+5mA
D1	AC_OK	AC Source Voltage OK Signal (Internally pull up to VSTANDBY by 10KΩ (3.3V & 5V VSTANDBY). 10KΩ (to 5V) for 12 VSTANDBY	>2.4V (Active, OK) <0.4V (not OK)	+4mA -2mA
D2	P_GOOD	Power Good Signal (Internally pull up to VSTANDBY by 10KΩ (3.3V & 5V VSTANDBY). 10KΩ (to 5V) for 12 VSTANDBY	>2.4V (Active, GOOD) <0.4V (not GOOD)	+4mA -2mA
A1	PS_KILL	Floating pin; will turn off main output	>2.4V "high" <0.4V "low"	
B5	PS_PRESENT	Tied internally to VSTANDBY Return	0V	
C1	PS_ON_L	Internally pull up to VSTANDBY by 1KΩ; can be driven with open drain/collector switches	>2.4V "high" <0.4V "low"	
A4	I <sup>2</sup> C_SDA0 (SDA)	I <sup>2</sup> C compatible Data Bus	>2.4V "high" <0.4V "low"	
A5	I <sup>2</sup> C_SCL0 (SCL)	I <sup>2</sup> C compatible Data Bus		
B3	I <sup>2</sup> C_SDA1 (SDA)	I <sup>2</sup> C compatible Data Bus		
B4	I <sup>2</sup> C_SCL1 (SCL)	I <sup>2</sup> C compatible Data Bus		
B2	SYS_CONTR	Host system control that can be used to turn on/off the Main 54V DC Output via an internal output switch within power module. Low turns "on" output switch		

### MATING CONNECTOR

Supplier	Press Fit, Straight	Press Fit, Right Angle	Solder Straight	Solder Right Angle
FCI	--	--	--	51762-1060-2000-ABLF

**WIRING DIAGRAM FOR OUTPUT**

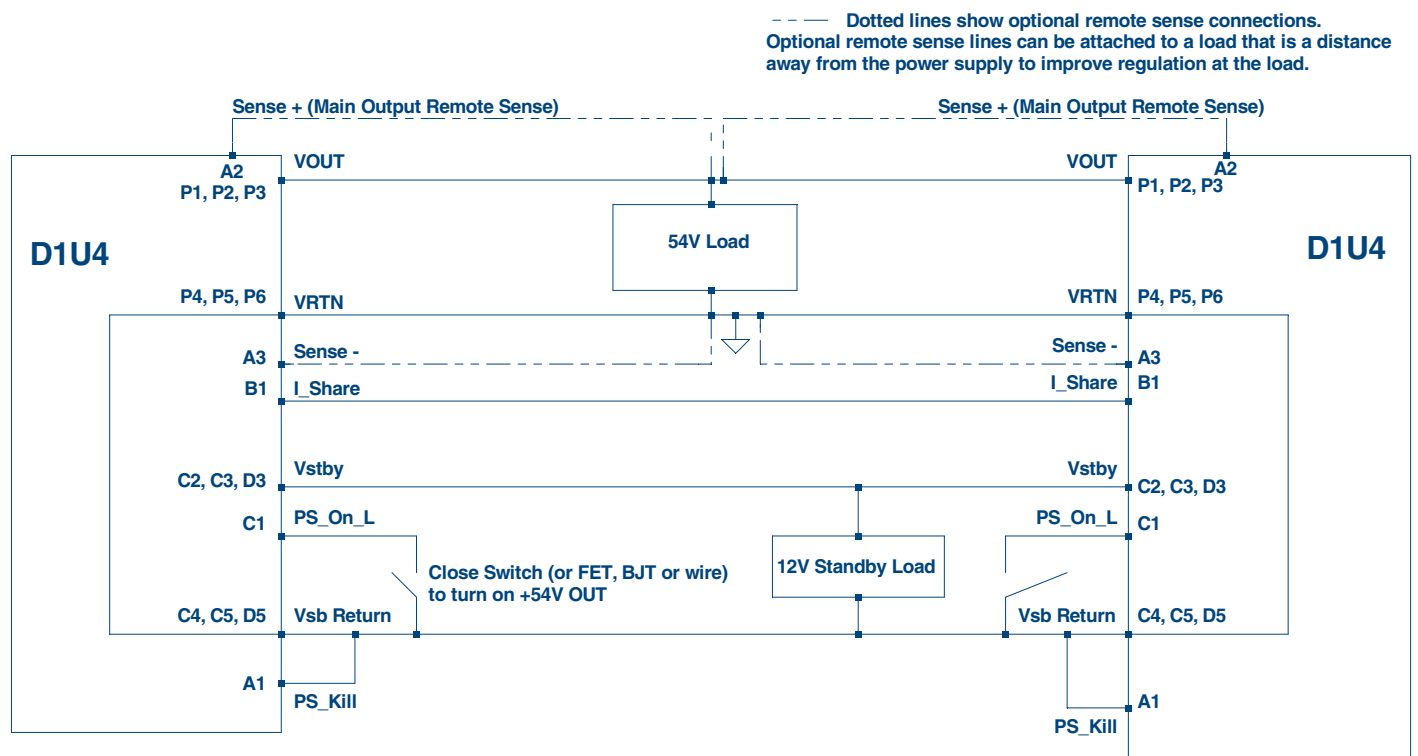

**CURRENT SHARING NOTES**

1. Main 54VDC Output: Analogue active share bus. The ISHARE bus (Pin B1) must be connected on all sharing modules. It is not required that the SENSE signals are connected to the remote load for current share to operate correctly.
2. Up to eight (8) power modules can be connected in parallel (non-redundant) or N+1 configuration. The current share bus is analogue bi-directional (can source or sink current from the ISHARE bus). The voltage of the bus would measure 8VDC for a single power module at 100% load; for two (2) modules sharing a common load the ISHARE bus voltage would be 4V for a perfect 50/50 current share scenario.
3. VSTANDBY output power modules can also be connected in parallel; however the combined available power is limited to that available from a single power module (12V; 2A; 24W) irrespective of the number of PS modules connected in parallel.

**MECHANICAL DIMENSIONS**

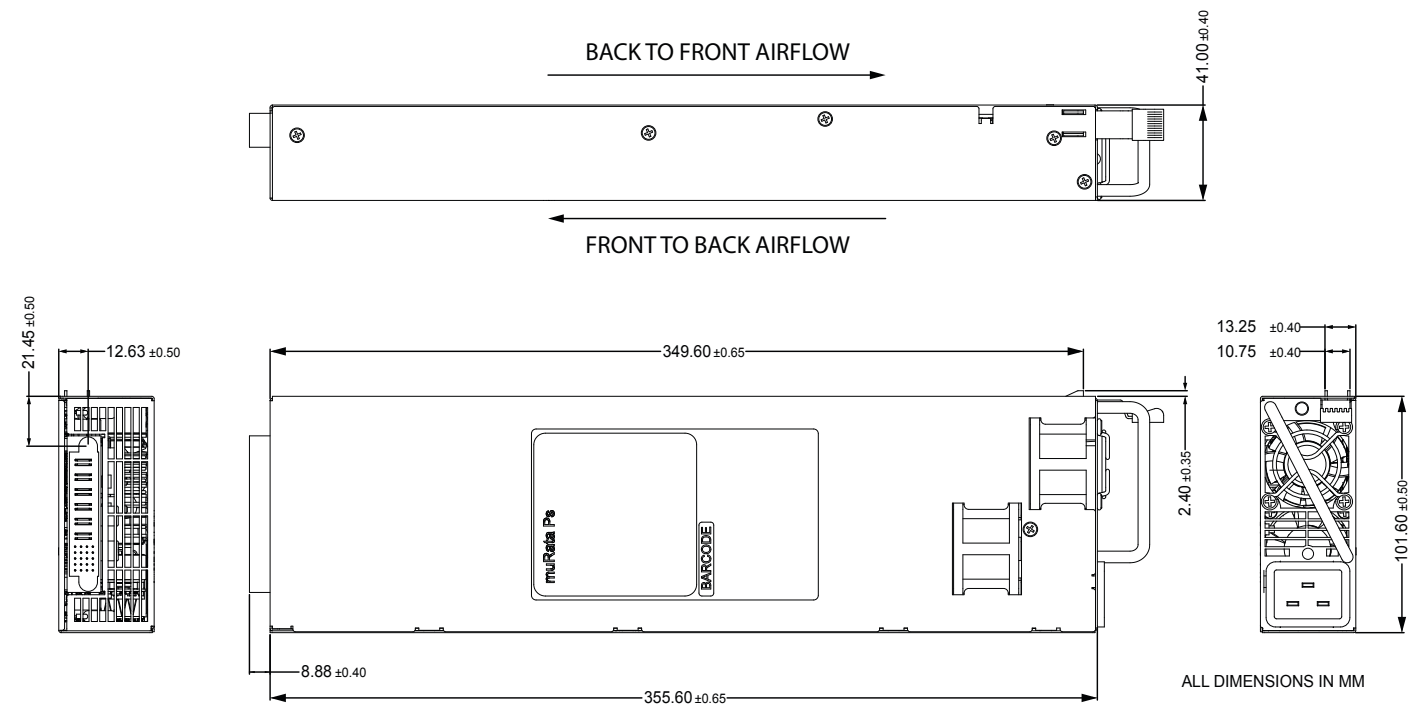

AC Input Connector/Inlet: IEC 60320-C20  
 Dimensions: 4.00" x 14.00" x 1.6" [101.6mm x 355.6mm x 41.0mm]

**OPTIONAL ACCESSORIES**

Description	Part Number
D1U4-54 Output Interface Connector Card	D1U4-54-CONC

**APPLICATION NOTES**

Document Number	Description	Link
ACAN-52	D1U4-54-CONC Output Connector Card	<a href="http://www.murata-ps.com/data/apnotes/acan-52.pdf">www.murata-ps.com/data/apnotes/acan-52.pdf</a>
ACAN-53	D1U4 Communications Protocol	<a href="http://www.murata-ps.com/data/apnotes/acan-53.pdf">www.murata-ps.com/data/apnotes/acan-53.pdf</a>

Murata Power Solutions, Inc.  
 129 Flanders Road, Westborough, MA 01581 U.S.A.  
 ISO 9001 and 14001 REGISTERED



**This product is subject to the following operating requirements and the Life and Safety Critical Application Sales Policy:**  
 Refer to: <http://www.murata-ps.com/requirements/>

Murata Power Solutions, Inc. makes no representation that the use of its products in the circuits described herein, or the use of other technical information contained herein, will not infringe upon existing or future patent rights. The descriptions contained herein do not imply the granting of licenses to make, use, or sell equipment constructed in accordance therewith. Specifications are subject to change without notice.  
 © 2018 Murata Power Solutions, Inc.

单击下面可查看定价，库存，交付和生命周期等信息

[>>Murata\(村田\)](#)