

PX1002

**86.85 MHz
SAW Filter**

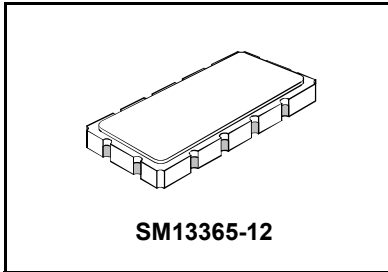

- **Designed for TDMA IS-54 Receiver IF Applications**
- **Low Insertion Loss**
- **Excellent Selectivity**
- **Hermetic 13.3 X 6.5 mm Surface-mount Case**
- **Unbalanced Input and Output**

Absolute Maximum Ratings

Rating	Value	Units
Maximum Incident Power in Passband	+10	dBm
Maximum DC Voltage Between any 2 terminals	30	VDC
Storage Temperature Range	-40 to +85	°C
Suitable for Lead-free Soldering - Maximum Soldering Profile	260 °C for 30 s	

Electrical Characteristics

Characteristic	Sym	Notes	Min	Typ	Max	Units
Nominal Center Frequency	f_C	1	86.850			MHz
Passband Insertion Loss at f_C 3 dB Passband Amplitude Ripple over $f_C \pm 15$ kHz Group Delay Variation over $f_C \pm 10$ kHz	IL	1, 2		3	4.0	dB
	BW_3		± 12	± 25		kHz
	GDV				1.0	dB _{P-P}
Third-Order Intermod. for -20 dBm tones at $f_C \pm 60$ & 120 kHz					6.0	μ S _{P-P}
Rejection $f_C \pm 60$ kHz $f_C - 880$ kHz to $f_C - 940$ kHz Ultimate		1, 2, 3			-95	dBm
			11	16		dB
			65		65	
Operating Temperature Range	T_A	1	-20		+70	°C

Impedance Matching to 50 Ω unbalanced	External L-C
Case Style	SM13365-12 13.3 X 6.5 mm Nominal Footprint
Lid Symbolization (YY=year, WW=week) See note 4	RFM PX1002 YYWW
Standard 7" Reel Quantity	500 units
Standard 13" Reel Quantity	1000 units

Electrical Connections

Connection	Terminals
Port 1 Hot	2
Port 1 Gnd Return	3
Port 2 Hot	8
Port 2 Gnd Return	9
Case Ground	All Others

Caution: Electrostatic Sensitive Device. Observe precautions for handling.

NOTES:

1. Unless noted otherwise, all specifications apply over the operating temperature range with filter soldered to the specified demonstration board with impedance matching to 50 Ω and measured with 50 Ω network analyzer.
2. Unless noted otherwise, all frequency specifications are referenced to the nominal center frequency, f_C .
3. Rejection is measured as attenuation below the minimum IL point in the passband. Rejection in final user application is dependent on PCB layout and external impedance matching design. See Application Note No. 42 for details.
4. "LRIP" or "L" after the part number indicates "low rate initial production" and "ENG" or "E" indicates "engineering prototypes."
5. The design, manufacturing process, and specifications of this filter are subject to change.
6. Either Port 1 or Port 2 may be used for either input or output in the design. However, impedances and impedance matching may vary between Port 1 and Port 2, so that the filter must always be installed in one direction per the circuit design.
7. US and international patents may apply.
8. Murata, stylized Murata logo, and Murata N.A., Inc. are registered trademarks of Murata Manufacturing Co., Ltd.

Discontinued

SCHEMATIC, PX1002 (DEMO)

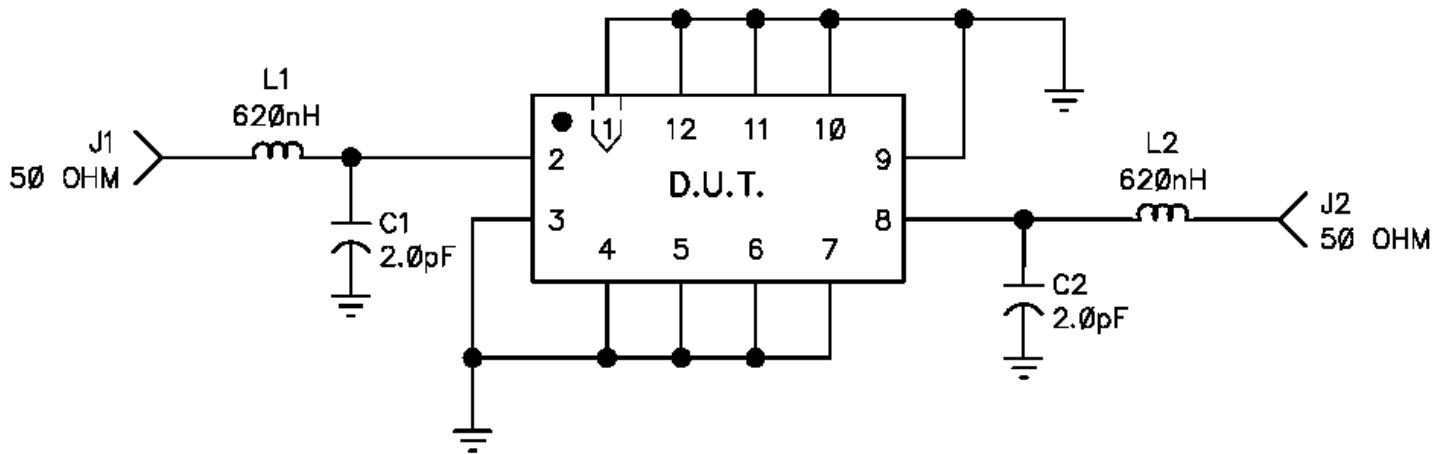

Discontinued

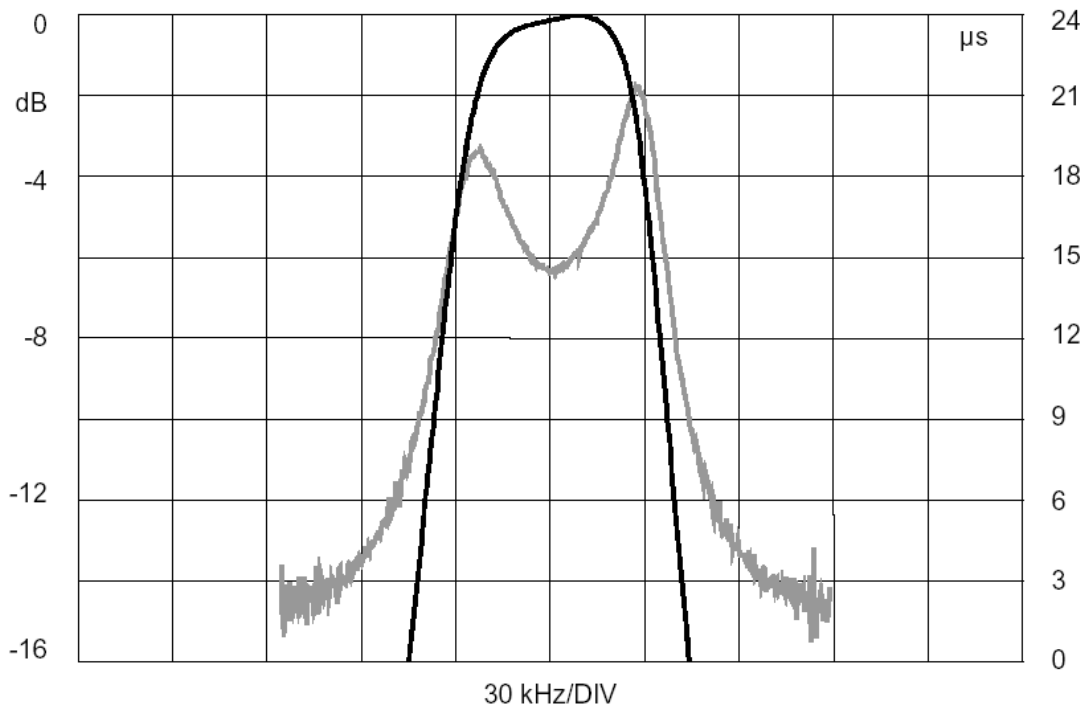
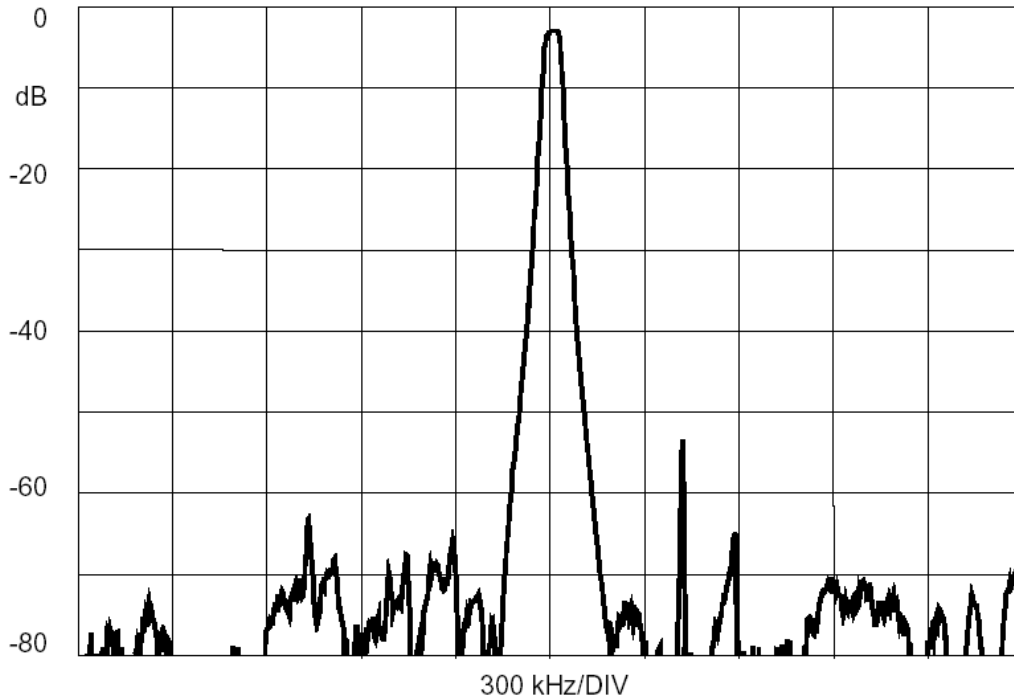

Discontinued

Tape and Reel Specifications

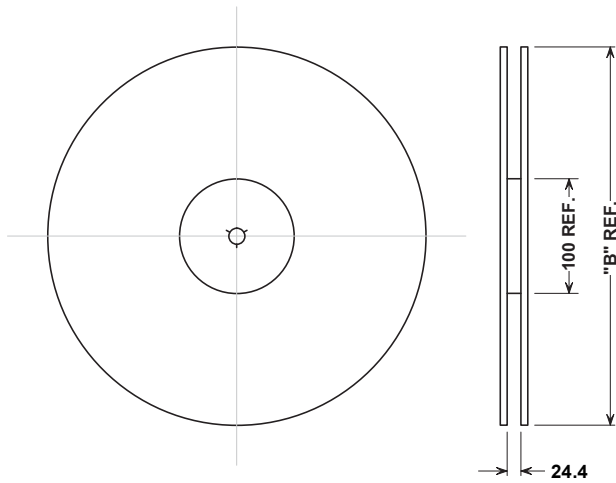

"B"		Quantity Per Reel
Inches	millimeters	
7	178	500
13	330	3000

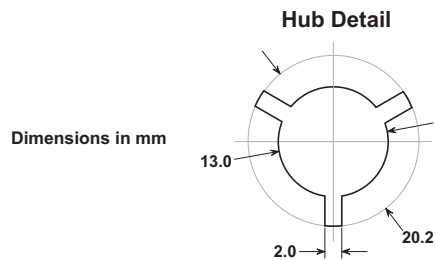

COMPONENT ORIENTATION and DIMENSIONS

Carrier Tape Dimensions	
Ao	7.0 mm
Bo	13.8 mm
Ko	2.0 mm
Pitch	12.0 mm
W	24.0 mm

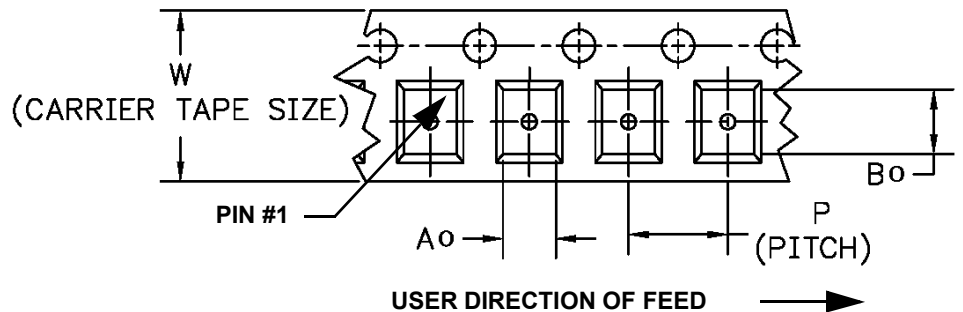
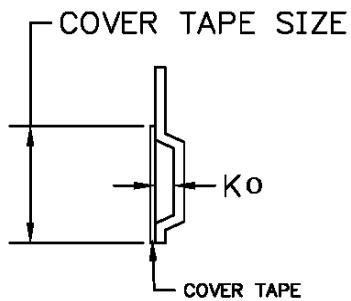

Discontinued

SM13365-12 Case

12-Terminal Ceramic Surface-Mount Case 13.3 x 6.5 mm Nominal Footprint

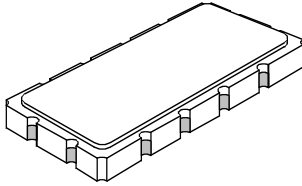

Case Dimensions						
Dimension	mm			Inches		
	Min	Nom	Max	Min	Nom	Max
A	13.08	13.31	13.60	0.515	0.524	0.535
B	6.27	6.50	6.80	0.247	0.256	0.268
C		1.91	2.00		0.075	0.079
D		1.50			0.059	
E		0.79			0.031	
H		1.0			0.039	
P		2.54			0.100	

Materials	
Solder Pad Plating	0.3 to 1.0 μm Gold over 1.27 to 8.89 μm Nickel
Lid Plating	2.0 to 3.0 μm Nickel
Body	Al_2O_3 Ceramic
Pb Free	

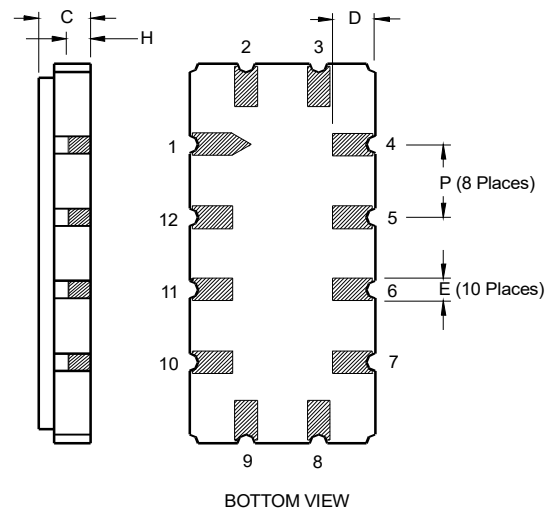
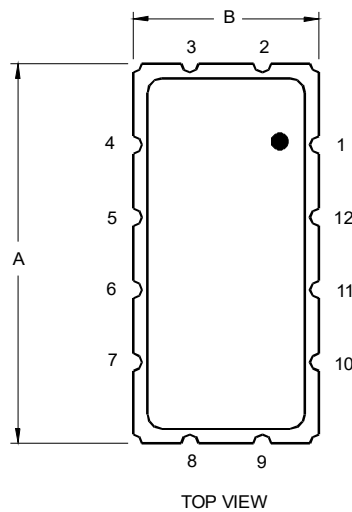
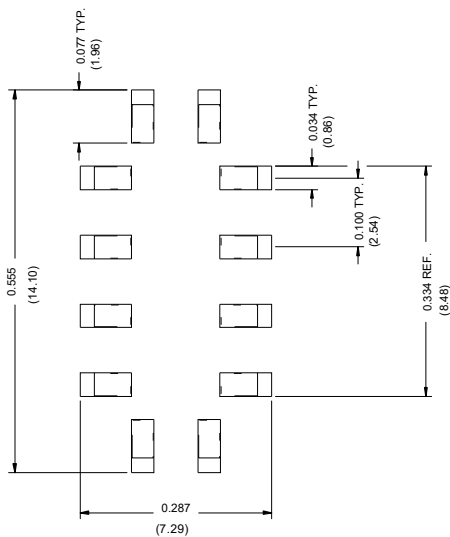

单击下面可查看定价，库存，交付和生命周期等信息

[>>Murata\(村田\)](#)