

**RO3073E-1**

**315.0 MHz  
SAW  
Resonator**

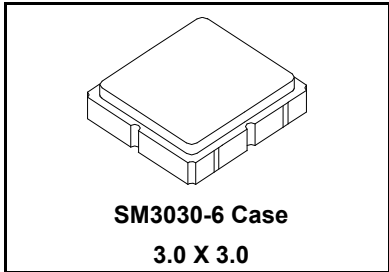

- **Ideal for 315 MHz Automotive-Keyless-Entry Transmitters**
- **Very Low Series Resistance**
- **Quartz Stability**
- **Complies with Directive 2002/95/EC (RoHS)**



The RO3073E-1 is a true one-port, surface-acoustic-wave (SAW) resonator in a surface-mount, ceramic case. It provides reliable, fundamental-mode, quartz frequency stabilization of local oscillators operating at approximately 315 MHz. This SAW was designed for AM transmitters in automotive-keyless-entry applications operating in the USA under FCC Part 15, in Canada under DoC RSS-210, and in Italy.

**Absolute Maximum Ratings**

Rating	Value	Units
Input Power Level	0	dBm
DC Voltage	12	VDC
Storage Temperature Range	-40 to +125	°C
Operating Temperature Range	-40 to +105	°C
Soldering Temperature (10 seconds / 5 cycles max.)	260	°C

Characteristic		Sym	Notes	Minimum	Typical	Maximum	Units
Frequency (+25 °C)	Absolute Frequency	$f_C$	2, 3, 4, 5	314.950		315.050	MHz
	Tolerance from 315.0 MHz	$\Delta f_C$				±50	kHz
Insertion Loss		IL	2, 5, 6		1.6	2.4	dB
Quality Factor	Unloaded Q	$Q_U$			8200		
	50 Ω Loaded Q	$Q_L$			1350		
Temperature Stability	Turnover Temperature	$T_O$	6, 7, 8	10	25	35	°C
	Turnover Frequency	$f_O$			$f_C$		
	Frequency Temperature Coefficient	FTC			0.032		ppm/°C <sup>2</sup>
Frequency Aging	Absolute Value during the First Year	$ f_A $	1, 6		10		ppm/yr
DC Insulation Resistance between Any Two Terminals			5	1.0			MΩ
RF Equivalent RLC Model	Motional Resistance	$R_M$	5, 7, 9		19.8		Ω
	Motional Inductance	$L_M$			82		μH
	Motional Capacitance	$C_M$			3.1		fF
	Shunt Static Capacitance	$C_O$		5, 6, 9	4.1		pF
Test Fixture Shunt Inductance		$L_{TEST}$	2, 7		63		nH
Lid Symbolization				802 // YWWS			
Standard Reel Quantity	Reel Size 7 Inch		10	500 Pieces / Reel			
	Reel Size 13 Inch			3000 Pieces / Reel			

**CAUTION: Electrostatic Sensitive Device. Observe precautions for handling.**

- NOTES:**
1. Frequency aging is the change in  $f_C$  with time and is specified at +65°C or less. Aging may exceed the specification for prolonged temperatures above +65°C. Typically, aging is greatest the first year after manufacture, decreasing in subsequent years.
  2. The center frequency,  $f_C$ , is measured at the minimum insertion loss point,  $IL_{MIN}$ , with the resonator in the 50 Ω test system (VSWR ≤ 1.2:1). The shunt inductance,  $L_{TEST}$ , is tuned for parallel resonance with  $C_O$  at  $f_C$ . Typically,  $f_{OSCILLATOR}$  or  $f_{TRANSMITTER}$  is approximately equal to the resonator  $f_C$ .
  3. One or more of the following United States patents apply: 4,454,488 and 4,616,197.
  4. Typically, equipment utilizing this device requires emissions testing and government approval, which is the responsibility of the equipment manufacturer.
  5. Unless noted otherwise, case temperature  $T_C = +25°C ± 2°C$ .
  6. The design, manufacturing process, and specifications of this device are subject to change without notice.
  7. Derived mathematically from one or more of the following directly measured parameters:  $f_C$ , IL, 3 dB bandwidth,  $f_C$  versus  $T_C$ , and  $C_O$ .
  8. Turnover temperature,  $T_O$ , is the temperature of maximum (or turnover) frequency,  $f_O$ . The nominal frequency at any case temperature,  $T_C$ , may be calculated from:  $f = f_O [1 - FTC (T_O - T_C)^2]$ . Typically *oscillator*  $T_O$  is approximately equal to the specified *resonator*  $T_O$ .
  9. This equivalent RLC model approximates resonator performance near the resonant frequency and is provided for reference only. The capacitance  $C_O$  is the static (nonmotional) capacitance between the two terminals measured at low frequency (10 MHz) with a capacitance meter. The measurement includes parasitic capacitance with "NC" pads unconnected. Case parasitic capacitance is approximately 0.05 pF. Transducer parallel capacitance can be calculated as:  $C_P \approx C_O - 0.05 \text{ pF}$ .
  10. Tape and Reel Standard Per ANSI / EIA 481.

RFM products are now  
Murata products.

## Electrical Connections

The SAW resonator is bidirectional and may be installed with either orientation. The two terminals are interchangeable and unnumbered. The callout NC indicates no internal connection. The NC pads assist with mechanical positioning and stability. External grounding of the NC pads is recommended to help reduce parasitic capacitance in the circuit.

Pin	Connection
1	NC
2	Terminal
3	NC
4	NC
5	Terminal
6	NC

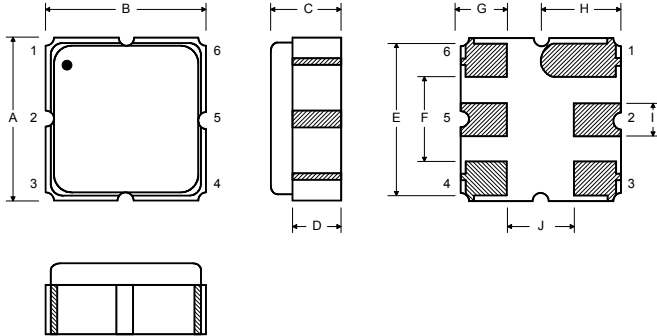

## Case Dimensions

Dimension	mm			Inches		
	Min	Nom	Max	Min	Nom	Max
A	2.87	3.0	3.13	0.113	0.118	0.123
B	2.87	3.0	3.13	0.113	0.118	0.123
C	1.12	1.25	1.38	0.044	0.049	0.054
D	0.77	0.90	1.03	0.030	0.035	0.040
E	2.67	2.80	2.93	0.105	0.110	0.115
F	1.47	1.6	1.73	0.058	0.063	0.068
G	0.72	0.85	0.98	0.028	0.033	0.038
H	1.37	1.5	1.63	0.054	0.059	0.064
I	0.47	0.60	0.73	0.019	0.024	0.029
J	1.17	1.30	1.43	0.046	0.051	0.056

## Typical Test Circuit

The test circuit inductor,  $L_{TEST}$ , is tuned to resonate with the static capacitance,  $C_O$ , at  $F_C$ .

## Electrical Test

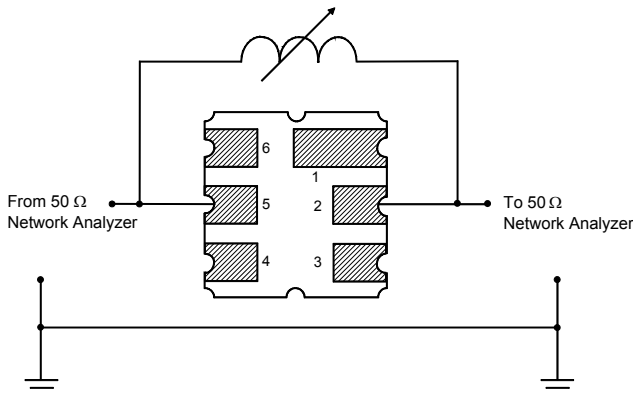

## Power Test

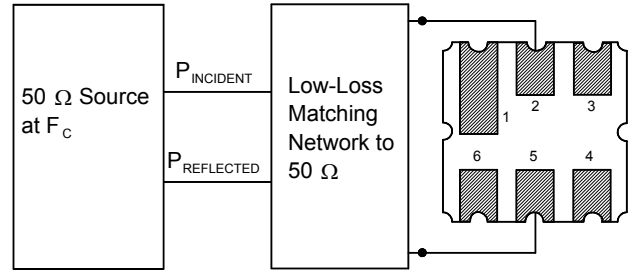

## Typical Application Circuits

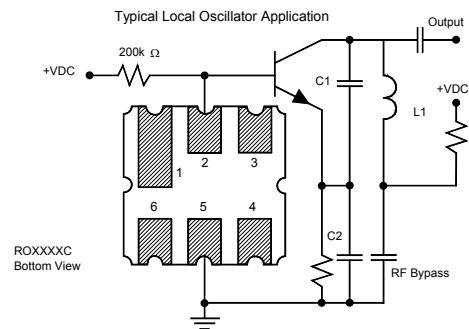
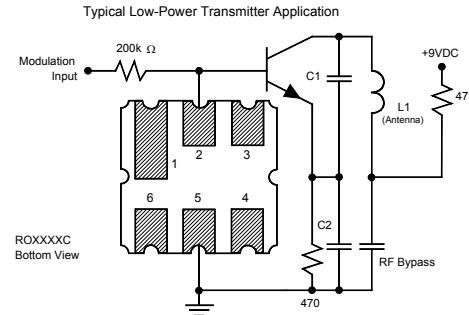

## Equivalent LC Model

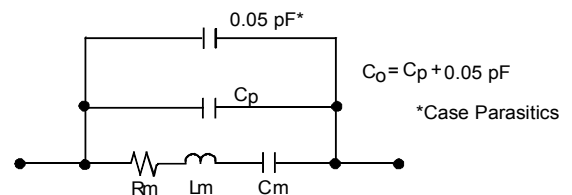

## Temperature Characteristics

The curve shown on the right accounts for resonator contribution only and does not include LC component temperature contributions.

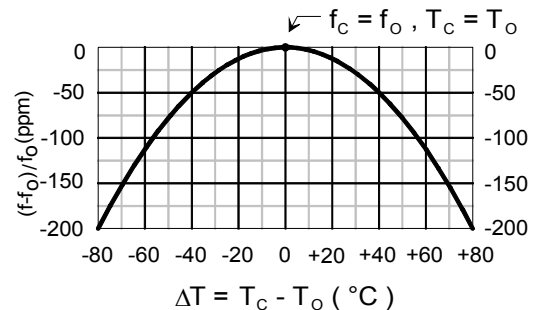

单击下面可查看定价，库存，交付和生命周期等信息

[>>Murata\(村田\)](#)