

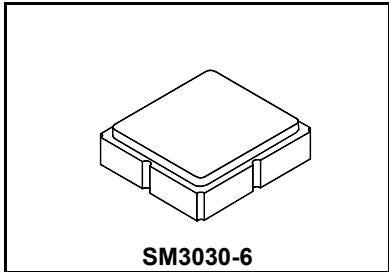

SF2036E

**1880 MHz
SAW Filter**



- *Low Insertion Loss L-Band SAW Filter*
- *3.0 X 3.0 mm Surface-Mount Case*
- *Complies with Directive 2002/95/EC (RoHS)* 

Absolute Maximum Ratings

Rating	Value	Units
Maximum Incident Power in Passband	+10	dBm
DC Voltage on any Non-ground Terminal	5	V
Operable Temperature Range	-45 to +125	°C
Specification Temperature Range	-30 to +85	°C
Storage Temperature Range in Tape and Reel	-40 to +85	°C
Maximum Soldering Profile, 5 Cycles Maximum	265 °C for 10 s	

Electrical Characteristics

Characteristic	Sym	Notes	Min	Typ	Max	Units
Center Frequency	f_C			1880		MHz
Insertion Loss, 1850 to 1910 MHz	IL			2.45	4.0	dB
Amplitude Ripple, 1850 to 1910 MHz				1.2	2.5	dB _{p-p}
Attenuation Referenced to 0 dB:						
DC to 1660 MHz			20	32		dB
1660 to 1721 MHz			30	35		dB
1721 to 1800 MHz			20	37		dB
1930 to 1990 MHz			7	19		dB
2000 to 2040 MHz			25	37		dB
2040 to 2480 MHz			31	38		dB
3700 to 3820 MHz			25	35		dB
Input/Output Return Loss, 1850 to 1910 MHz			7.4	13		dB
Source Impedance	Z_S			50		Ω
Load Impedance	Z_L			50		Ω
Case Style	SM3030-6 3 x 3 mm Nominal Footprint					
Lid Symbolization, Y=year, WW=week, S=shif	510 YWWS					

Electrical Connections

Connection	Terminals
Input	2
Output	5
Ground	All others



CAUTION: Electrostatic Sensitive Device. Observe precautions for handling.

NOTES:

1. Unless noted otherwise, all specifications apply over the operating temperature range with filter soldered to the specified demonstration board with impedance matching to 50 Ω and measured with 50 Ω network analyzer.
2. Unless noted otherwise, all frequency specifications are referenced to the nominal center frequency, f_C .
3. Rejection is measured as attenuation below the minimum IL point in the passband. Rejection in final user application is dependent on PCB layout and external impedance matching design. See Application Note No. 42 for details.
4. The design, manufacturing process, and specifications of this filter are subject to change.
5. US and international patents may apply.
6. Murata, stylized Murata logo, and Murata N.A., Inc. are registered trademarks of Murata Manufacturing Co., Ltd.

**Frequency Characteristics :
Transfer function**

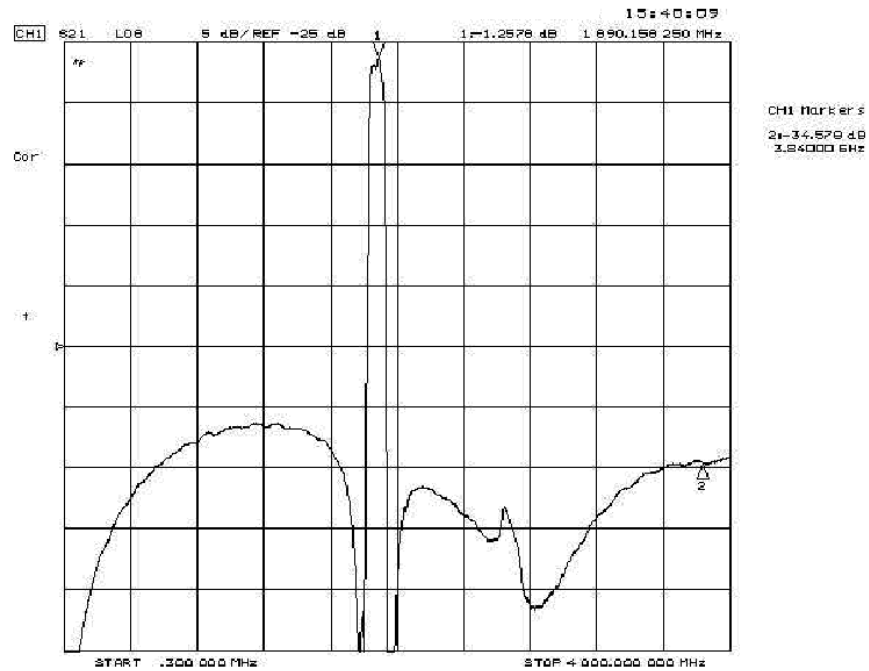
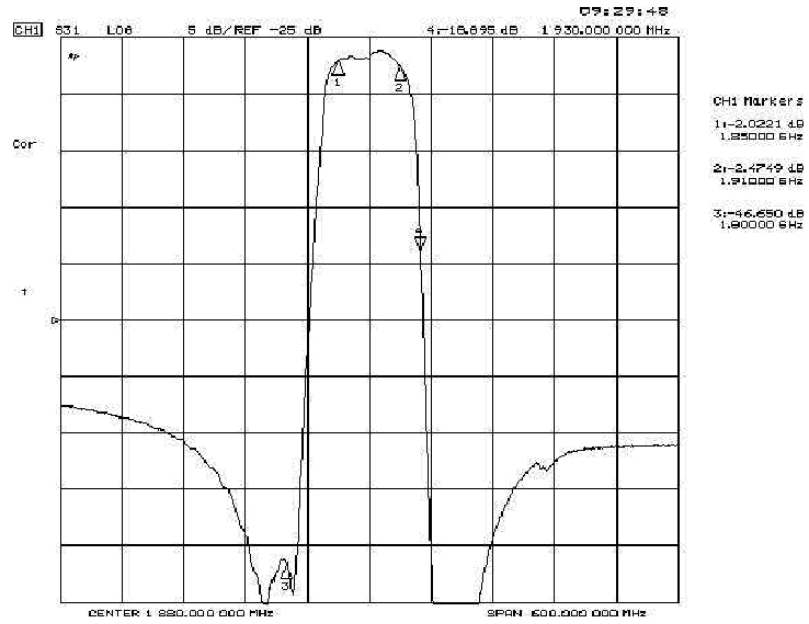

S11

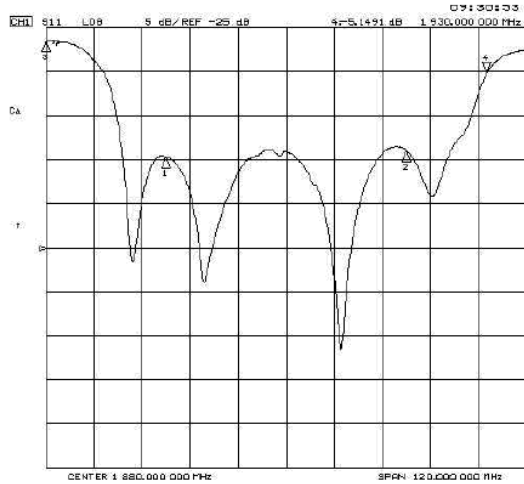

CH1 Markers

1	-1.4639 dB	1.880000 GHz
2	-1.3870 dB	1.910000 GHz
3	-1.3889 dB	1.920000 GHz

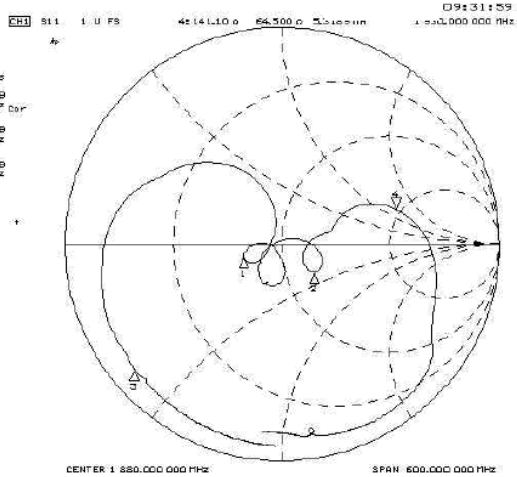

CH1 Markers

1	134.939 n	-4.3281 n	1.880000 GHz
2	265.307 n	-17.4777 n	1.910000 GHz
3	313.2109 n	-18.4110 n	1.920000 GHz

S22

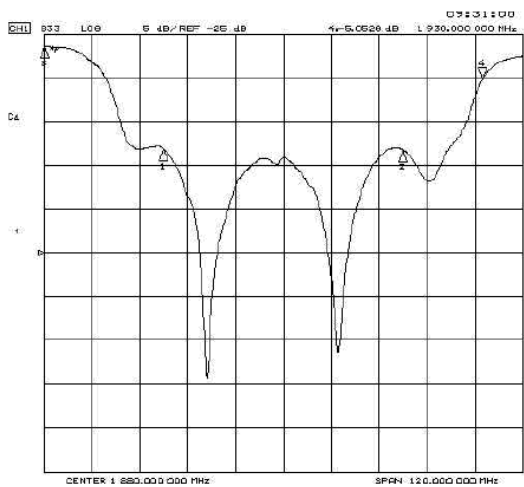

CH1 Markers

1	-13.156 dB	1.880000 GHz
2	-13.2362 dB	1.910000 GHz
3	-13.2764 dB	1.920000 GHz

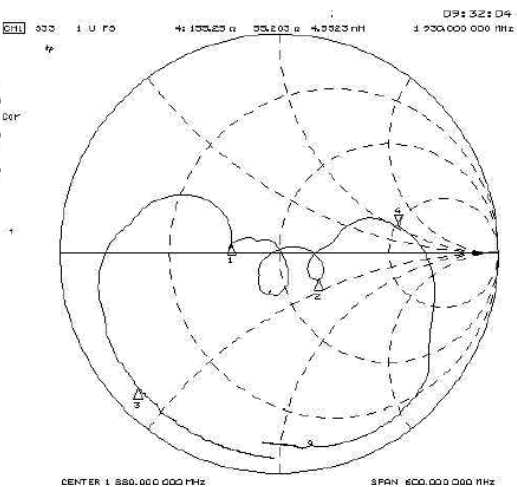

CH1 Markers

1	132.140 n	2.9961 n	1.880000 GHz
2	165.670 n	-17.3888 n	1.910000 GHz
3	133.320 n	-23.1100 n	1.920000 GHz

SM3030-6 Case

6-Terminal Ceramic Surface-Mount Case 3.0 X 3.0 mm Nominal Footprint

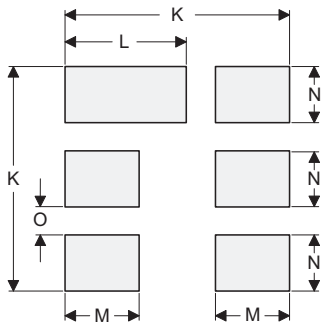

PCB Footprint Top View

Case and PCB Footprint Dimensions

Dimension	mm			Inches		
	Min	Nom	Max	Min	Nom	Max
A	2.87	3.00	3.13	0.113	0.118	0.123
B	2.87	3.00	3.13	0.113	0.118	0.123
C	1.12	1.25	1.38	0.044	0.049	0.054
D	0.77	0.90	1.03	0.030	0.035	0.040
E	2.67	2.80	2.93	0.105	0.110	0.115
F	1.47	1.60	1.73	0.058	0.063	0.068
G	0.72	0.85	0.98	0.028	0.033	0.038
H	1.37	1.50	1.63	0.054	0.059	0.064
I	0.47	0.60	0.73	0.019	0.024	0.029
J	1.17	1.30	1.43	0.046	0.051	0.056
K		3.20			0.126	
L		1.70			0.067	
M		1.05			0.041	
N		0.81			0.032	
O		0.38			0.015	

Case Materials

Materials	
Solder Pad Plating	0.3 to 1.0 μm Gold over 1.27 to 8.89 μm Nickel
Lid Plating	2.0 to 3.0 μm Nickel
Body	Al_2O_3 Ceramic
Pb Free	

Top View

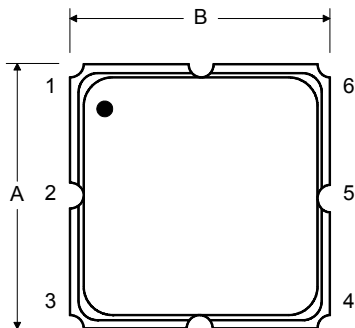

Bottom View

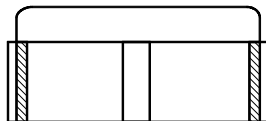
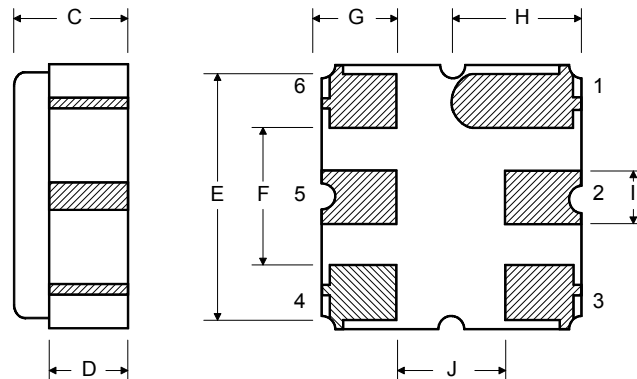

Tape and Reel Specifications

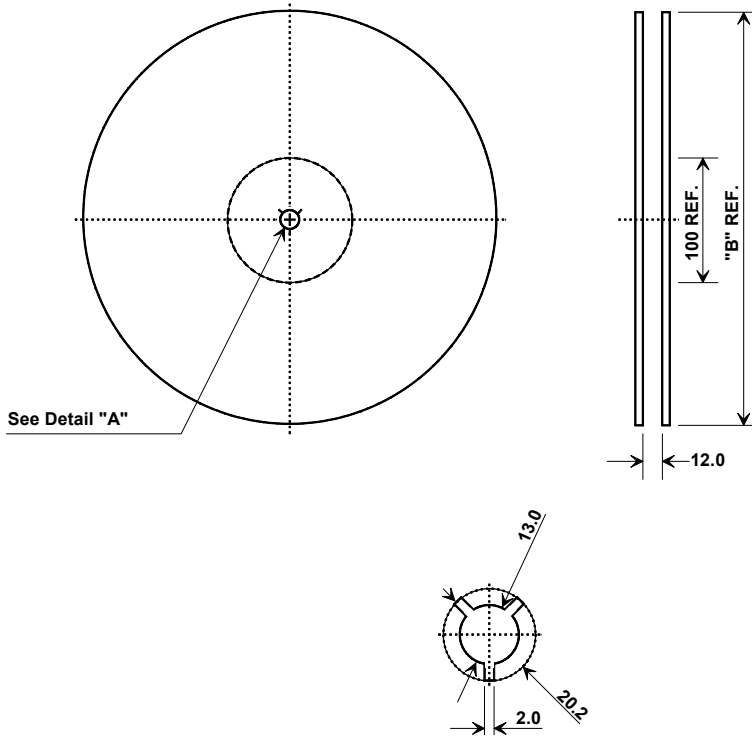

"B"		Quantity Per Reel
Nominal Size		
Inches	millimeters	
7	178	500
13	330	3000

COMPONENT ORIENTATION and DIMENSIONS

Carrier Tape Dimensions	
Ao	3.35 mm
Bo	3.35 mm
Ko	1.4 mm
Pitch	8.0 mm
W	12.0 mm

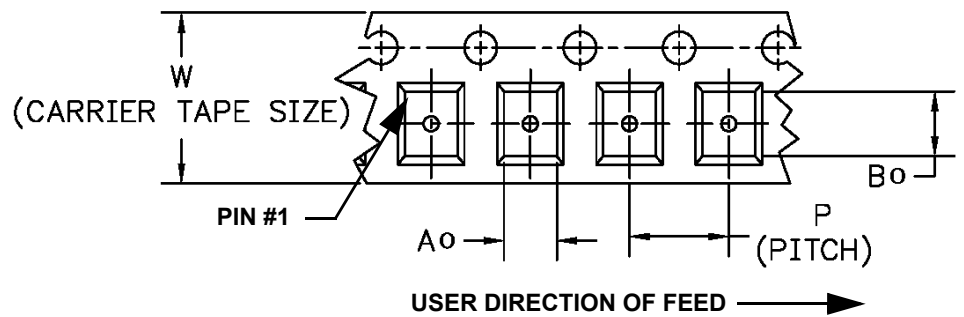
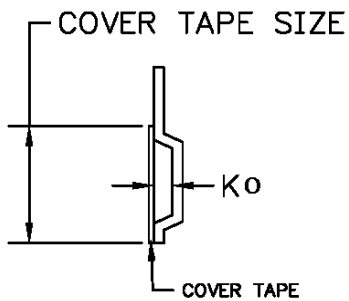

单击下面可查看定价，库存，交付和生命周期等信息

[>>Murata\(村田\)](#)