

Specification
No. G100280A0052Z1 - 1 to 8

Electrolytic Capacitors Specifications

Customer Part No. : _____

Customer Specification No. : _____

Nippon Chemi-Con Part No. : EKXG451ELL820MM30S

Nippon Chemi-Con Corporation

Chemi-Con Iwate Corporation

Design Group Manager

T. Hino

Receipt Stamp

Change history of specifications

Specifications No.	Revision date	Pages/section revised	Changes made	Reasons for changes
G100280A005Z1	Mar.18.2010	--	First issue	-

1 Scope

This specification defines the requirements for aluminum electrolytic capacitors KXG series.

2 Part Numbering System

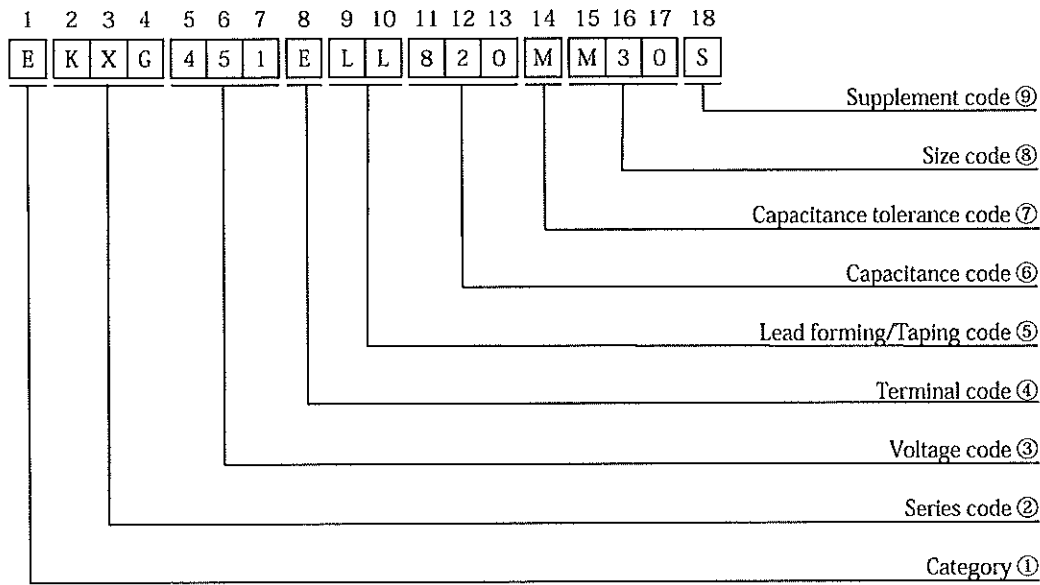

① Category

Category	Code
	1st
Polar	E

⑥ Capacitance code

Capacitance[μ F]	Capacitance code		
	11th	12th	13th
82	8	2	0

② Series code

Series name	Series code		
	2nd	3rd	4th
KXG	K	X	G

⑦ Capacitance tolerance code

Capacitance tolerance [%]	Capacitance tolerance code
	14th
± 20	M

③ Voltage code

Voltage [V]	Voltage code		
	5th	6th	7th
450	4	5	1

⑧ Size code

ϕ D	Size code	L	Size code	
	15th		16th	17th
18	M	30	3	0

④ Terminal code

Terminal configuration	Terminal code
	8th
Radial lead	E

⑨ Supplement code

Sleeve material	Terminal plating material	Supplement code
		18th
PET	Sn	S

⑤ Lead forming/Taping code

Type	Shape/contents	Lead forming/Taping code	
		9th	10th
Lead forming (Radial lead/Bulk)	Straight	L	L

3 Appliance and dimensions

Long lead

Lead forming code : L L

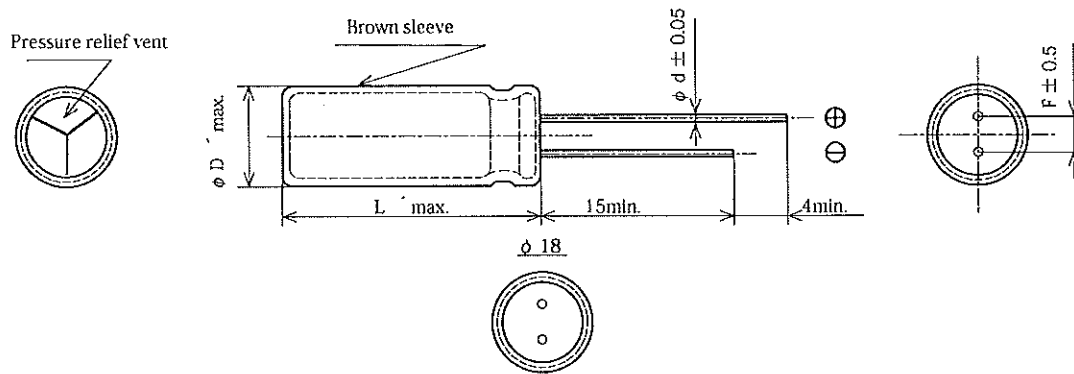

Dimension	[mm]
ϕD	18
L	30
ϕd	0.8
F	7.5
L	$L + 2.0 \times 1$
ϕD	$\phi D + 0.5 \times 1$

※ 1 ϕD , L : Nominal case size

4 Construction

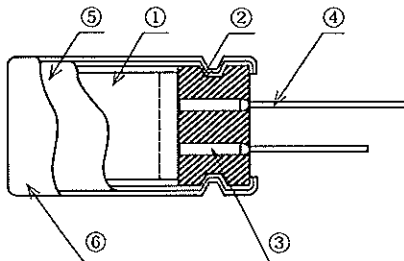

No.	Compositions	Materials
①	Anode foil	Aluminum
	Cathode foil	Aluminum
	Separator	Paper
	Fixing tape	Polypropylene(PP)
②	Seal	Rubber
③	Aluminum tab	Aluminum
④	Lead wire	Tinned copper clad steel
⑤	Case	Aluminum
⑥	Sleeve	Polyester

※ No ozone depleting substance has been used.

RoHS Directive(2002/95/EC)

Substances banned in the RoHS directive are not used in these products.

5 Rating and characteristics

No.	Item	Specification
1	Category temperature range	- 25 to + 105°C
2	Rated voltage range	450V _{DC}
3	Surge voltage	Table-1
4	Rated capacitance range	See the standard rating table
5	Capacitance tolerance	- 20 to + 20%
6	Dissipation factor(tan δ)	See the standard rating table
7	Leakage current	See the standard rating table
8	Rated ripple current	See the standard rating table

Table-1 Surge voltage

Rated voltage [V _{DC}]	450
Surge voltage [V _{DC}]	495

Rated ripple current multipliers

Frequency multipliers

Frequency [Hz]	120	1k	10k	100k
Capacitance [μ F]				
82	1.00	1.75	2.25	2.50

When a frequency is different from the specified condition shown in the table of standard ratings, do not exceed the value obtained by multiplying the permissible maximum ripple current by the multiplier above.

6 Marking

The following items shall be marked on each capacitor. (White marking)

- | | |
|------------------------------|--------------------------------------|
| ① Rated voltage | ⑤ Manufacturer's identification mark |
| ② Rated capacitance | ⑥ Capacitance tolerance code |
| ③ Upper category temperature | ⑦ Lot No. |
| ④ Negative polarity marking | ⑧ Series name |

Finish method

The negative polarity marking (stripe) is made to distinguish the negative lead.

(Example)

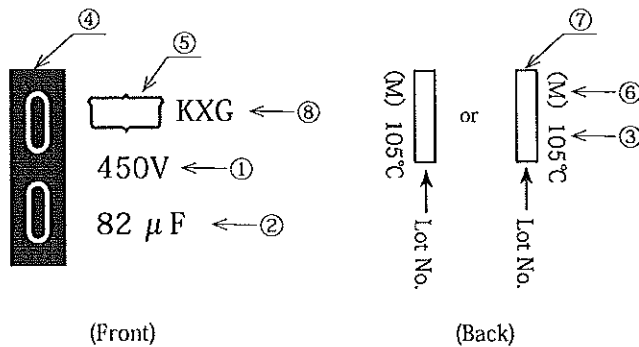

7 Performance

Unless otherwise specified, the capacitors shall be measured at a temperature at + 15 to + 35°C , a humidity of 45 to 75% RH and a atmospheric pressure of 86 to 106kPa. However, if any doubt arises on the judgment, the measurement conditions shall be + 20 ± 2°C, 60 to 70% RH and 86 to 106kPa.

7.1 Leakage current (L.C.)

[Conditions] Rated voltage shall be applied to capacitors in series with a resistor of $1000 \pm 10 \Omega$.Then leakage current shall be measured at the end of a specified period after the capacitors reached the rated voltage across the terminals.

[Criteria] Shall not exceed the values specified in the table of Standard Ratings.

7.2 Capacitance (Cap.)

[Conditions] Measuring frequency : 120Hz ± 20%
 Measuring voltage : 0.5V_{rms} max. + 1.5 to 2.0V_{DC}
 Measuring circuit : Series equivalent circuit (○—||—○)

[Criteria] Shall be within the specified capacitance tolerance.

7.3 Dissipation factor (tan δ)

[Conditions]	Measuring frequency	: 120Hz \pm 20%
	Measuring voltage	: 0.5Vrms max. + 1.5 to 2.0Vdc
	Measuring circuit	: Series equivalent circuit (O— — —O)
[Criteria]	Shall not exceed the values specified in the table of Standard Ratings.	

7.4 Terminal strength

(1) Pull strength

[Conditions] The capacitor body shall be held. A force shall be gradually applied to the lead wire in the direction of the axis of the lead wire up to the specified pull force, and retained for 10 \pm 1 seconds.

Nominal lead diameter [mm]	Pull force [N]
Over 0.5 to 0.8 incl.	10

[Criteria] The lead wire shall neither loosen nor break away.

(2) Lead bending strength

[Conditions] The capacitor shall be held so that the normal axis of the lead wire can be in a vertical position. A weight equivalent to the specified load shall be hung on the end of the lead wire. The capacitor body shall be inclined through 90° and returned to its normal position within 2 to 3 seconds. The consecutive bend shall then be in the opposite direction in the same manner.

Nominal lead diameter [mm]	Bending load [N]
Over 0.5 to 0.8 incl.	5

[Criteria] The lead wire shall neither loosen nor break away.

7.5 Soldering heat

[Conditions]	Type of solder	: Sn-3Ag-0.5Cu
	Flux	: Ethanol solution (25 wt.% rosin)
	Solder temperature/immersion time	: + 260 \pm 5°C for 10 \pm 1 seconds or + 380 \pm 10°C for 3 \pm 0.5 seconds.
	Depth of immersion	: Up to 1.5 to 2.0mm from the root of the lead wire covered with a thermal shield plate
[Criteria]	Speed of immersion	: 25 \pm 2.5mm/sec.
	Appearance	: No significant damage.
	Leakage current	: Shall not exceed the initial specified value.
	Capacitance change	: Shall be within \pm 10% of the initial measured value.
	Tan δ	: Shall not exceed the initial specified value.

7.6 Solderability

[Conditions]	Type of solder	: Sn-3Ag-0.5Cu
	Flux	: Ethanol solution (25 wt.% rosin)
	Solder temperature	: + 245 \pm 3°C
	Depth of immersion	: Up to 1.5 to 2.0mm
	Immersion time	: 2 to 3sec.
[Criteria]	Solder shall cover at least 3/4 of the lead surface immersed.	

7.7 Vibration

[Conditions]	Vibration frequency range	: 10 to 55Hz
	Amplitude or Acceleration	: 0.75 mm (Half amplitude) or 98m/s ² (Whichever is less severe)
	Sweep rate	: 10 to 55 to 10Hz in about 1 minute
	Direction and period of motion	: 2 hours in each of 3 mutually perpendicular directions (total of 6 hours)
Note: Capacitors shall be mounted on the pc board with their lead wires anchored at 4mm max. of their bodies, except for the capacitors with the case size ϕ 16 x30L, whose lead wire shall be anchored at 1mm max. of their bodies. The body of the capacitor with 12.5mm or larger in diameter or 25mm or longer in length, in addition, shall be anchored to the pc board with a fixture.		
[Criteria]	Appearance	: No significant damage, legible marking, and no electrolyte leakage.
	Capacitance change	: Shall be within \pm 5% of the initial measured value.

7.8 Damp heat

[Conditions]	Test temperature	: + 40 ± 2°C
	Relative humidity	: 90 to 95% RH
	Test time	: 240 ± 8 hours
[Criteria]	Appearance	: No significant damage, legible marking, and no electrolyte leakage.
	Leakage current	: Shall not exceed the initial specified value.
	Capacitance change	: Shall be within ± 20% of the initial measured value.
	Tan δ	: Shall not exceed 120% of the initial specified value.

7.9 Endurance

[Conditions]	After the capacitors are put to a DC voltage with the rated ripple current within the rated voltage for the specified test of time at + 105 ± 2°C, the following specifications shall be satisfied when the capacitors are restored to + 20°C. The sum of a DC voltage and a peak AC voltage must not exceed their full rated voltage.	
	Specified test time	: 10,000 ± 7% hours
[Criteria]	Appearance	: No significant damage, legible marking, and no electrolyte leakage.
	Leakage current	: Shall not exceed the initial specified value.
	Capacitance change	: Shall be within ± 20% of the initial measured value.
	Tan δ	: Shall not exceed 200% of the initial specified value.

7.10 Surge voltage test

[Conditions]	Test temperature	: + 15 to + 35°C
	Series protective resistor	: 1000 ± 10 Ω
	Test voltage	: Surge voltage shown in Table-1
	Applying of voltage	: 30 ± 5 seconds every 6 ± 0.5 minutes.
	Test cycle	: 1000 cycle.
[Criteria]	Appearance	: No significant damage and no electrolyte leakage.
	Leakage current	: Shall not exceed the initial specified value.
	Capacitance change	: Shall be within ± 20% of the initial measured value.
	Tan δ	: Shall not exceed 200% of the initial specified value.

7.11 Pressure relief vent

[Conditions]	Apply a reverse voltage with the DC current of 1 amp.(DC reverse voltage test)
[Criteria]	When the pressure relief vent operated, the capacitor shall not flame although emission of gas or a part of the inside element is allowable.

If the vent does not operate with the voltage applied for 30 minutes, the test is considered to be passed.

7.12 High Temperature Storage

[Conditions]	The following specifications shall be satisfied when the capacitors are restored to + 20°C after exposing them for 1,000 ± 4% hours at + 105 ± 2°C without an applied voltage. Before the measurements, the capacitor shall be preconditioned by applying voltage according to Item 4.1 of JIS C 5101-4.	
[Criteria]	Appearance	: No significant damage, legible marking, and no electrolyte leakage.
	Leakage current	: Shall not exceed 500% of the initial specified value.
	Capacitance change	: Shall be within ± 20% of the initial measured value.
	Tan δ	: Shall not exceed 200% of the initial specified value.

7.13 High and Low Temperature characteristics

[Conditions]

Step	Temperature [°C]	
1	+ 20 ± 2	Step 1 : Measure capacitance, tan δ and impedance
2	- 25 ± 3	Step 2 : Measure impedance
3	+ 105 ± 2	Step 3 : Measure capacitance, tan δ and a leakage current.

[Criteria] Step 2 : Impedance ratio shall not exceed the values shown in Table attached.

[120Hz]	
Rated voltage [V _{DC}]	450
Z - 25°C / Z + 20°C	6

Step 3 : Leakage current : Shall not increase 8 times more than the initial specified value.
 Capacitance change : Shall be within ± 25% of the initial measured value.
 Tan δ : Shall not exceed the initial specified value.

8 Reference standard

KXG series is applicable to general-purpose grade capacitors of JIS C 5101-4-1-1998.
 The other test conditions shall comply with JIS C 5101-4-1998 and JIS C 5101-1998.

9 Others

9.1 Export Trade Control Ordinance (When our product our is exported from Japan)

(1) Export Trade Control Ordinance (Section 1 through 15 of Appendix Table 1)

Export regulation of the capacitors for pulse use (750V or higher) and the capacitors for high voltage (5,000V or higher) is carried out according to (item 4 1-4) in Section 2 of Appendix Table 1 (Section 49 in Chapter 1 of METI's Ordinance) and (item 7) in Section 7 of Appendix Table 1 (Section 6 in Chapter 6 of METI's Ordinance). However, the aluminum electrolytic capacitors, which are described in this specification, don't fulfill the regulated level. Therefore, the aluminum electrolytic capacitors are not applicable to Export Trade Control Ordinance.

(2) Export Trade Control Ordinance (Section 16 of Appendix Table 1)

The aluminum electrolytic capacitors, which are described in this specification, applicable to goods under Export Regulations (Category 85 of Appendix Table in Customs Tariff Law) based on Section 16 of Appendix Table 1 in Export Trade Control Ordinance.

If the exporter got information that their exporting goods are used to any development of massive weapon, the exporter must apply for exporting permission to Ministry of Economy, Trade and Industry (METI), and get METI's approval.

Regardless of the above, if the exporter is notified by METI that his/her exporting goods are potentially used to any development of extensive destructive weapons, the exporter must seek permission from METI to export, and get METI's approval. When Nippon Chemi-Con receives such notice from METI, we will inform your company of that.

9.2 Cleaning PC board

(1) Alcohol system

Higher alcohol system / Isopropyl alcohol cleaning agents

Recommended cleaning agents:

Pine Alpha ST-100S (Arakawa Chemical)

Clean Through 750H, 750K, 750L, and 710M (Kao)

Technocare FRW-14,15,16,17 (Momentive performance materials)

Cleaning conditions:

Using these cleaning agents, capacitors are capable of withstanding immersion or ultrasonic cleaning for 10 minutes at a maximum liquid temperature of 60°C. Find optimum condition for washing, rinsing, and drying. Be sure not to rub off the marking of the capacitors by coming in contact with any other components or PC board. Note that shower cleaning adversely affects the markings on the sleeve.

9.3 Manufacturing plant

CHEMI-CON IWATE CORPORATION (JAPAN)

P.T. INDONESIA CHEMI-CON (INDONESIA)

TAIWAN CHEMI-CO (TAIWAN)

SAMYOUNG ELECTRONICS CO., LTD. (KOREA)

QINGDAO SAMYOUNG ELECTRONICS CO., LTD. (CHINA)

CHEMI-CON (WUXI) CO., LTD. (CHINA)

9.4 For aluminum electrolytic capacitors, please refer to PRECAUTIONS AND GUIDELINES.

Standard Ratings

VV [Vdc]	Cap [μ F]	Case size ϕ D \times L [mm]	tan δ Max.	LC [μ A] Max.		Rated ripple current [mA _{rms} /105°C]		Part No.
				1 minute	5 minutes	120Hz	100kHz	
450	82	18 \times 30	0.24	1570	763	685	1710	EKXG451ELL820MM30S

单击下面可查看定价，库存，交付和生命周期等信息

[>>NCC\(贵弥功\(黑金刚\)\)](#)