

NX1210AB

For OA / AV / Short-range Wireless

■ Features

- Ultra compact and thin surface-mount type crystal unit.
- Ultra compact and thin (Typ. 1.2 × 1.0 × Typ. 0.25 , H : 0.30mm)
- Highly reliable crystal unit.
- A product with characteristics best suited for ultra compact Wireless LAN and Bluetooth.(For Short-range Wireless)
- A surface-mount crystal oscillator. (Reflow soldering is possible.)
- Lead-free. Meets the requirements for re-flow profiling using lead-free solder.

Pb Free

RoHS Compliant
Directive 2011/65/EU
Directive (EU) 2015/863

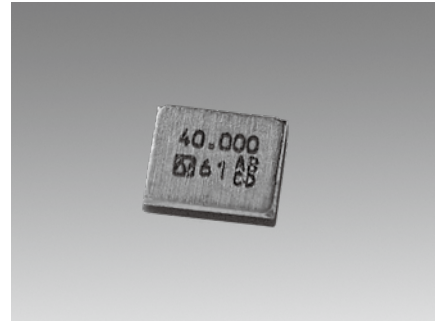

■ Specifications

Item	Model	NX1210AB	
		Standard	Optional
Standard		Standard	Optional
Nominal Frequency (MHz)		26 ≤ F ≤ 52	26 ≤ F ≤ 80
Overtone Order		Fundamental	Fundamental
Frequency Tolerance (25 ±3 °C)		±10 × 10 ⁻⁶	±10 × 10 ⁻⁶
Frequency versus Temperature Characteristics (with reference to +25 °C)		±15 × 10 ⁻⁶	±25 × 10 ⁻⁶ (Temp extended case, *1)
Operating Temperature Range (°C)		-30 to +85	-40 to +85 *1
Storage Temperature Range (°C)		-40 to +85	-40 to +85
Equivalent Series Resistance		Refer to *2	Refer to *3
Level of Drive (μW)		10 (Max. 100)	10 (Max. 100)
Load Capacitance (pF)		8	6 to 12
Frequency Aging (+25°C)		---	Max. ±3 × 10 ⁻⁶ / year *1
Specifications Number		STD-CIX-1	Refer to *3

Please specify the model name, frequency, and specification number when you order products.

For further questions regarding specifications, please feel free to contact us.

*1 If you have any other requests, NDK will study it.

*3 Ordering information: Overtone Order Fundamental / 3rd Overtone, the Operating Temperature Range, Frequency versus Temperature Characteristics, Frequency Tolerance, and Load Capacitance.

Ex. Model, Frequency (38.400000MHz 6digits), S1:Fundamental or S3:3rd Overtone

- Operating Temperature Range (-30 to +85°C) - Frequency versus Temperature Characteristics (±12×10⁻⁶)

- Frequency Tolerance (±12×10⁻⁶) - Load Capacitance (7pF)

NX1210AB

38.400000MHz

S1-3085-12-12-7

■ Dimensions

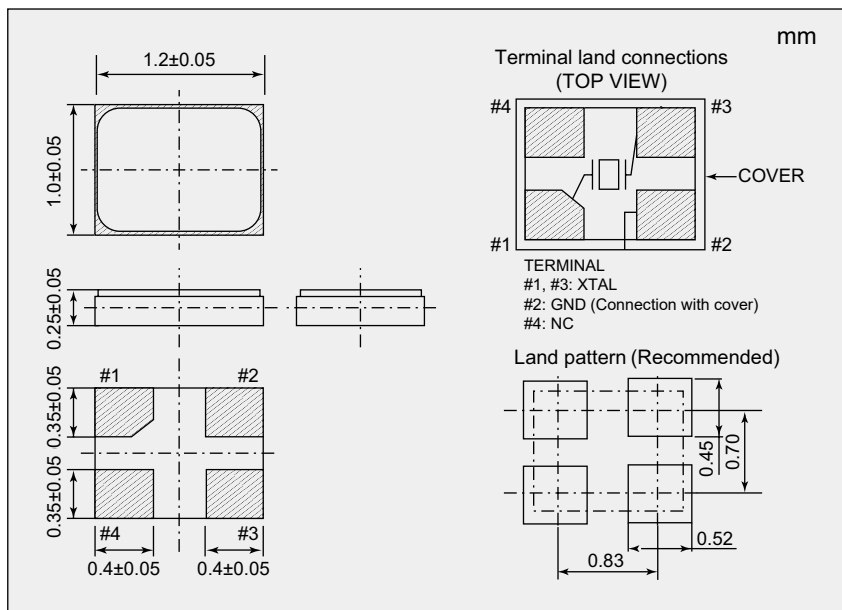

*2 Equivalent Series Resistance

Nominal Frequency (MHz)	Equivalent Series Resistance Max. (Ω)
26 ≤ F < 32	150
32 ≤ F < 40	100
40 ≤ F ≤ 52	60

*3 Equivalent Series Resistance

Nominal Frequency (MHz)	Equivalent Series Resistance Max. (Ω)
26 ≤ F < 32	150
32 ≤ F < 40	100
40 ≤ F ≤ 52	80
52 < F ≤ 80	60

单击下面可查看定价，库存，交付和生命周期等信息

[>>NDK\(电波\)](#)