



SPECIFICATION

Customer: Shanghai Tang Electronics CO.,LTD.

Item:	Crystal Unit
Type:	NX2520SA
Nominal Frequency:	16.000 MHz
Customer's Spec. No.:	
NDK Spec. No.:	STD-CSW-5

Receipt

Revision Record						
Rev.	Date	Items	Contents	Approved	Checked	Drawn
---	25.Mar.2021	Issue	---	M.Sato	---	R.Omomo

1. Customer's Spec. No. :
2. NDK Spec. No. : STD-CSW-5
3. Type : NX2520SA

4. Electrical Specifications

	Parameters	SYM.	Electrical Spec.				Notes
			min	typ	max	Units	
1	Nominal frequency	f_{nom}	16.000			MHz	
2	Overtone order	-	Fundamental			-	
3	Frequency tolerance	-	-15	-	+15	$\times 10^{-6}$	at + 25°C
4	Frequency versus temperature characteristics	-	-25	-	+25	$\times 10^{-6}$	at -40~+85°C The reference temperature shall be +25°C
5	Equivalent resistance	-	-	-	80	Ω	IEC PI-network/Series
6	Load capacitance	C_L	-	8	-	pF	IEC PI-network
7	Level of drive	-	-	10	200	μW	
8	Operating temperature range	T_{opr}	-40	-	+85	°C	
9	Storage temperature range	T_{str}	-40	-	+85	°C	
10	Insulation resistance	-	500	-	-	M Ω	When terminal to terminal and terminal to cover were applied at DC100V \pm 15V.
11	Air-tightness	-	-	-	1.1×10^{-9}	Pa m ³ /s	

5. Examination results document

Since a performance is guaranteed, an examination results document does not submit.

6. Application drawing

- 6.1 External dimension : EXD14B-00420
- 6.2 Taping and reel figure : EXK17B-00161
EXK17B-00410
- 6.3 Holder marking : EXH11B-00317
- 6.4 Reliability assurance Item : EXS30B-00249

7. Notes on use

7-1 Even if the appearance color etc. of the product differs by purchasing the component parts by more than two companies, there is no influence on the characteristics and reliability.

7-2 Since the crystal unit is a passive component, it is important to have appropriate circuit conditions. Please be sure to check the circuit conditions before using the crystal units, and ensure the necessary circuit margin, and confirm that the desired frequency is output. Moreover, please check the circuit conditions when using an existing crystal unit for another model or board.

If the circuit conditions are not appropriate, there is a risk of oscillation stop or frequency deviation.

7-3 IN THE CASE OF THE FOLLOWING ITEMS, WE ARE NOT RESPONSIBLE FOR WARRANTY / COMPENSATION.

(1) WHEN PRODUCTS OF THIS SPECIFICATION ARE USED FOR EQUIPMENT RELATED TO HUMAN LIFE OR PROPERTY, IT IS THE RESPONSIBILITY OF THE CUSTOMER TO CONFIRM THE INFLUENCE ON THIS PRODUCT AND EQUIPMENT TO BE USED BEFOREHAND, CONDUCT NECESSARY SAFETY DESIGN (INCLUDING REDUNDANT DESIGN, MALFUNCTION PREVENTION DESIGN, etc.), AND PLEASE USE IT AFTER SECURING SUFFICIENT SAFETY OF EQUIPMENT.

1. SAFETY-RELATED EQUIPMENT SUCH AS AUTOMOBILES, TRAINS, SHIPS, etc., OR EQUIPMENT DIRECTLY INVOLVED IN OPERATION
2. AIRCRAFT EQUIPMENT
3. SPACE EQUIPMENT
4. MEDICAL EQUIPMENT
5. MILITARY EQUIPMENT
6. DISASTER PREVENTION / CRIME PREVENTION EQUIPMENT
7. TRAFFIC LIGHT
8. OTHER EQUIPMENT REQUIRING THE SAME PERFORMANCE AS THE ABOVE-MENTIONED EQUIPMENT

(2) IN CASES WHERE IT IS NOT INDICATED IN THE REQUESTED STANDARD AND IS USED UNDER CONDITIONS OF USE (INCLUDING CIRCUIT MARGIN etc.) THAT CAN NOT BE PREDICTED AT THE PRODUCTION STAGE.

(3) WHEN USING ULTRASONIC WELDING MACHINE. (THERE IS A POSSIBILITY THAT THE CHARACTERISTIC DEGRADATION IS CAUSED BY THE RESONANCE PHENOMENON OF THE PIEZOELECTRIC MATERIAL. (EXAMPLE; CRYSTAL PIECE))
WE WILL NOT TAKE ANY RESPONSIBILITY FOR THE INFLUENCE OF THE CUSTOMERS' PROCESS.

SO, PLEASE SUFFICIENTLY EVALUATE AT A SAMPLE STEP WHEN YOU USE ULTRASONIC WELDING MACHINE.

(4) USING RESIN MOLD MAY AFFECT THE PRODUCT CHARACTERISTIC.

PLEASE MAKE SURE TO TELL OUR SALES CONTACT WHEN YOU USE RESIN MOLD. WE WILL PERFORM INDIVIDUAL CORRESPONDENCE ABOUT A DELIVERY SPECIFICATION AND AN EVALUATION METHOD.

IN ADDITION, IF YOU USE RESIN MOLD WITHOUT CONTACTING US, AND CAUSES DAMAGES AGAINST A CUSTOMER OR A THIRD PARTY, WE WILL NOT BE LIABLE FOR THE DAMAGES AND OTHER RESPONSIBILITIES BECAUSE WE CONSIDER IT IS UNDER SELF-RESPONSIBILITY USING RESIN MOLD.

WE WILL NOT TAKE ANY RESPONSIBILITY FOR THE INFLUENCE OF THE CUSTOMERS' PROCESS. PLEASE SUFFICIENTLY EVALUATE AT A SAMPLE STEP WHEN YOU USE RESIN MOLD.

(5) WHEN PERFORMING IMPROPER HANDLING THAT EXCEEDS THE GUARANTEED RANGE.

7-4 This product cannot be used for equipment related to the safety of automobiles or equipment directly involved in operation.(example: air bag, TPMS, engine control, steering control, brake control etc.)

8. Notes on storage

8-1 When storing the product in high temperature and high humidity condition for a long time, product characteristics (solderability etc.) and packaging condition may be deteriorated. Please store product at temperature + 5°C ~ + 35°C, humidity 85% RH or less. The product is an electronic component, so please do not storage and use, under a dewing state.

8-2 The product storage deadline is 12 months after delivery in unopened state. Please use within storage deadline. If you exceed storage deadline, please check the product characteristics etc, please use.

9. Other Requests

9-1 Please use this specification only for confirmation of the specification of this product.

9-2 If there is a change request, please contact within three weeks from issue date. If there is no communication, we will deliver the product under the contents of this specification. In addition, if the product delivery date is within 3 weeks and there is a change request, we will consult the processing separately.

9-3 NOTES THAT ARE DESCRIBED IN THIS DOCUMENT, IF YOU DID NOT COMPLY WITH THE PROHIBITIONS, AND OTHER PLEASE, INCLUDING THE FAILURE CORRESPONDENCE OR COMPENSATION OR DAMAGES, WE CAN NOT ASSUME THE RESPONSIBILITY, PLEASE UNDERSTAND.

10. Prohibited items

Be sure to use the product under the following conditions. Otherwise, the characteristics deterioration or destruction of the product may result.

(1) Reflow soldering heat resistance

Peak temperature: 260°C, 30 sec

Heating: 230°C or higher, 40 sec

Preheating: 150°C to 180°C, 120 sec

Reflow passage times: twice

(2) Manual soldering heat resistance

Pressing a soldering iron of 400°C on the terminal electrode for four seconds (twice)

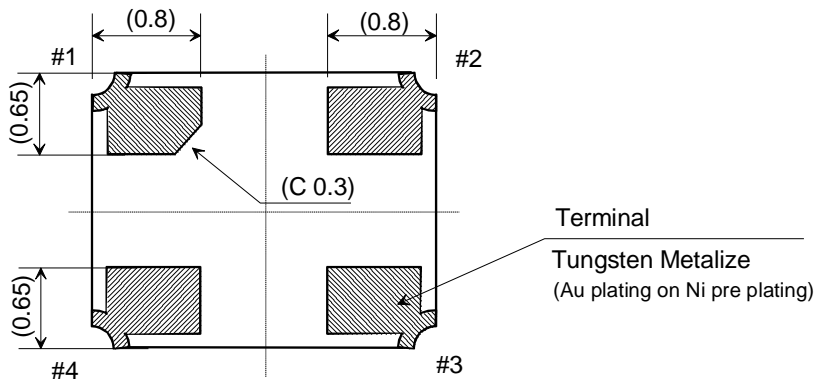
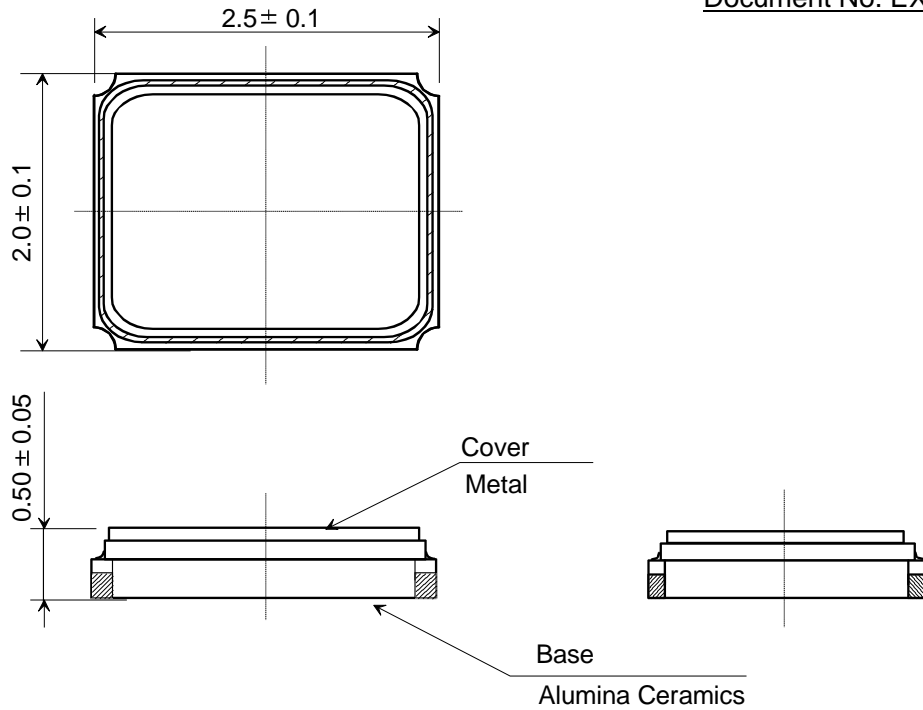

LAND PATTERN (Recommended)

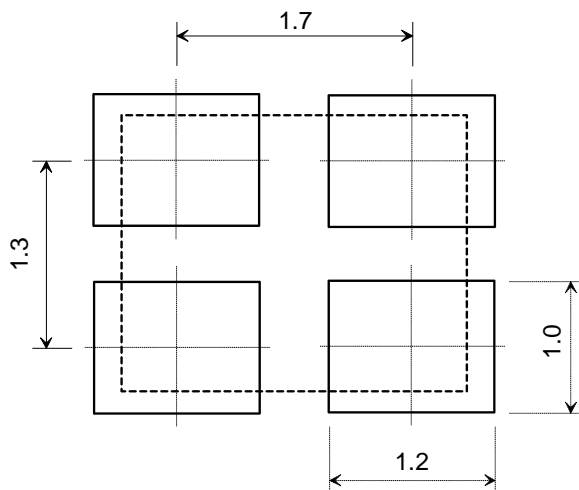

[TOP VIEW] PIN CONNECTION

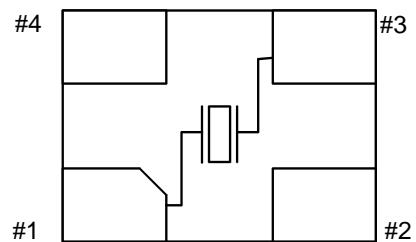

TERMINAL
#1,#3:X'tal
#2,#4:GND(CONNECTION COVER)

	Date of Revise	Charge	Approved	Reason	
B	09. Oct. 2019	E. Hayashida	H. Yamauchi	Revise Land pattern to Recommended.	
	Date	Name	Third Angle Projection	Tolerance	
Drawn	30.Oct.2007	K.Sato	Dimension:mm	---	
Designed	30.Oct.2007	K.Sato	Title NX2520SA Dimension Drawing	Drawing No. EXD14B-00420	
Checked	---	---			Rev.
Approved	30.Oct.2007	K.Kubota			B

NIHON DEMPA KOGYO CO., LTD.

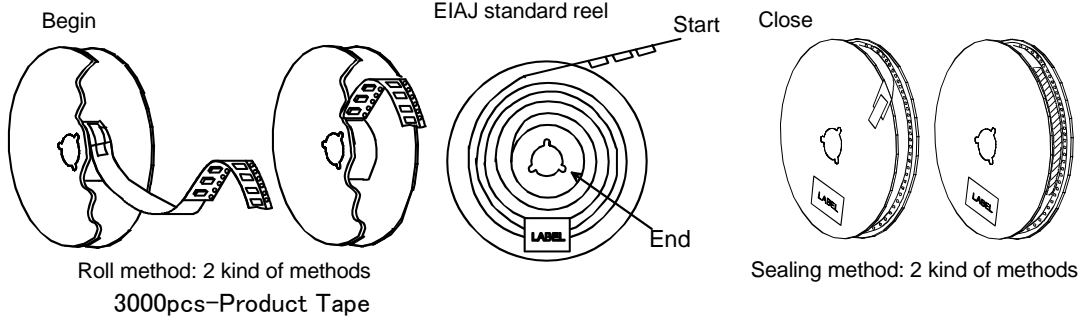
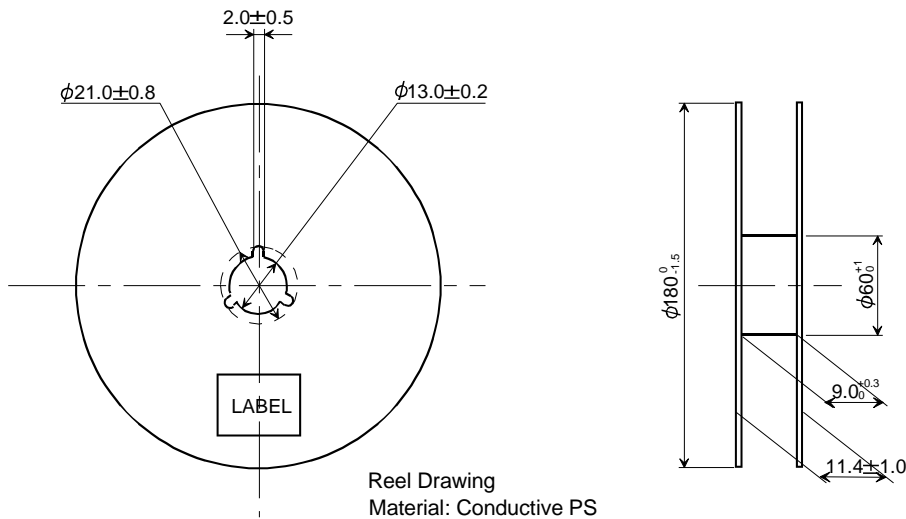
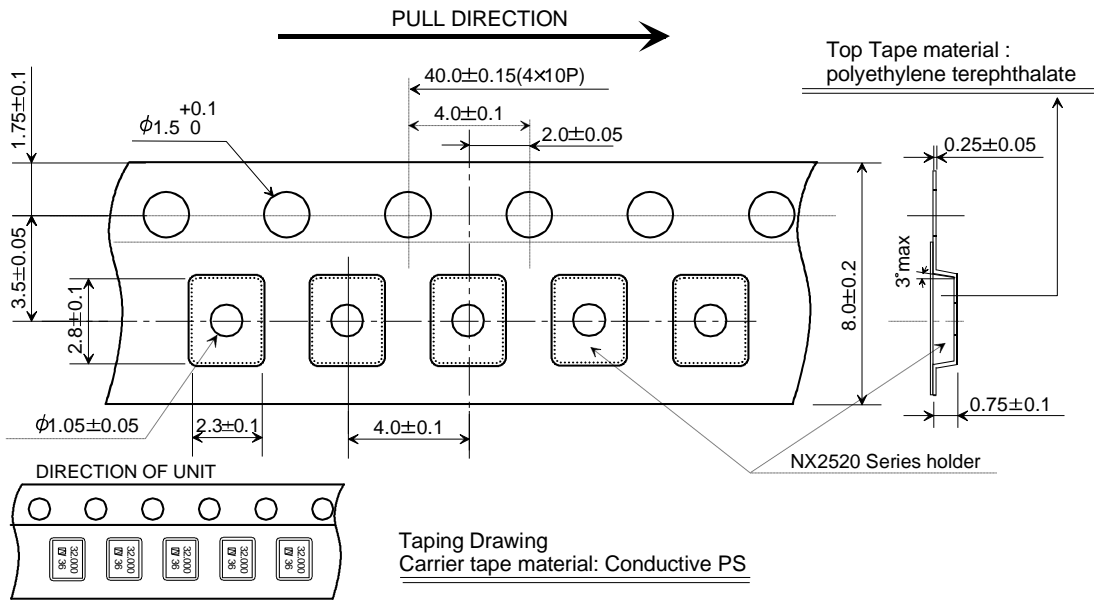

	Date of Revise	Charge	Approved	Reason	
C	7 Oct. 2016	H. Ohkubo	H. Murakoshi	Addition of roll method and sealing method.	
	Date	Name	Third Angle Projection	Tolerance	
Drawn	19.Jun.2003	H.Yagishita	Dimension: mm	----	
Designed	19.Jun.2003	H.Yagishita	Title NX2520 Series Taping and Reel Spec.	Drawing No. EXK17B-00161	
Checked	19.Jun.2003	K.Kubota			Rev.
Approved	19.Jun.2003	T.Ishii			C

NIHON DEMPA KOGYO CO., LTD.

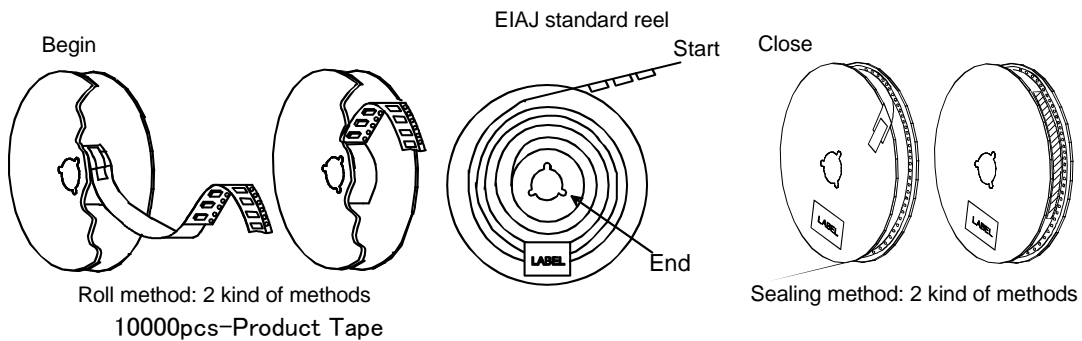
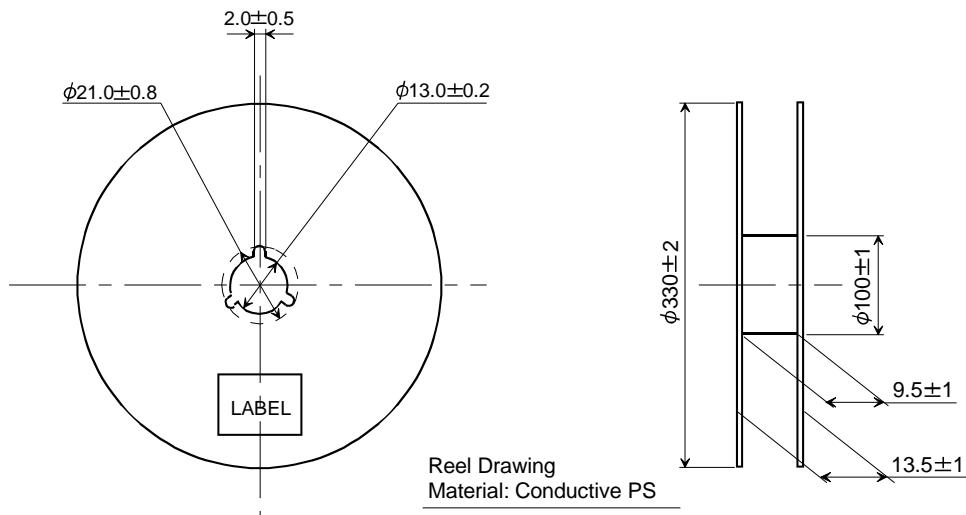
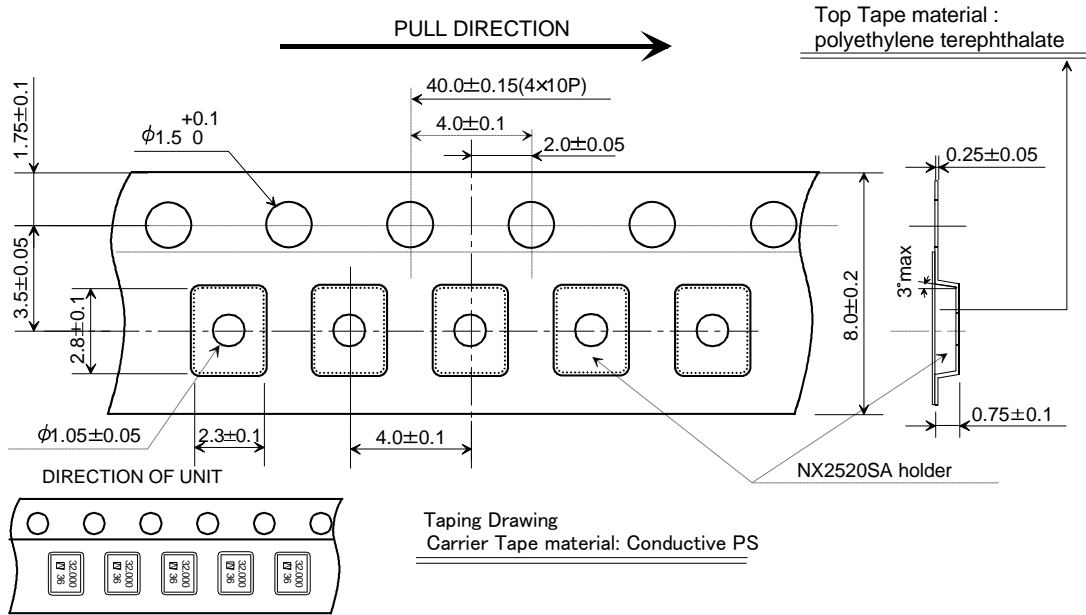

	Date of Revise	Charge	Approved	Reason	
D	15 Sep. 2017	S. Takeda	H. Murakoshi	NX2520SF was added.	
	Date	Name	Third Angle Projection	Tolerance	
Drawn	2 Sep. 2016	H. Ohkubo	Dimension: mm	----	
Designed	2 Sep. 2016	H. Ohkubo	Title NX2520SA, NX2520SD, NX2520SF Taping and Reel Spec.	Drawing No. EXK17B-00410	
Checked	---	---			Rev. D
Approved	2 Sep. 2016	H. Murakoshi			

NIHON DEMPA KOGYO CO., LTD.

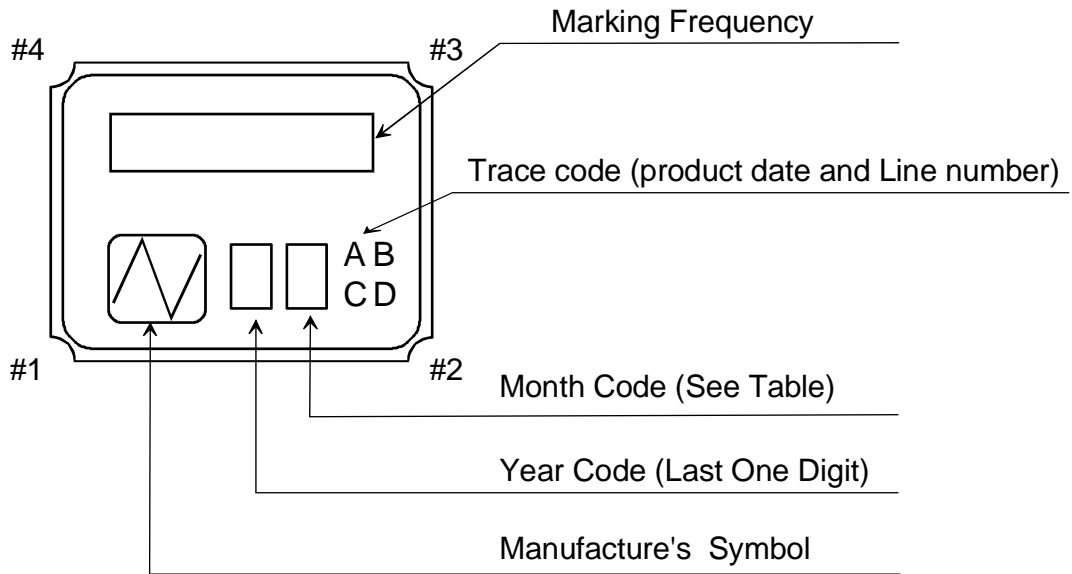

NOTE

1. Frequency Code

Marking Frequency is consist of five digits, first five digits of Nominal Frequency

Example

Nominal Frequency	28.636363 MHz
Frequency Code	28.636

2. Month Code Table

Month	1 Jan.	2 Feb.	3 Mar.	4 Apr.	5 May.	6 Jun.	7 Jul.	8 Aug.	9 Sep.	10 Oct.	11 Nov.	12 Dec.
Month Code	1	2	3	4	5	6	7	8	9	X	Y	Z

*Marking digits are not include a decimal point and dot mark.

	Date of Revise	Charge	Approved	Reason
D	10. Dec 2014	Y.Sakurai	H.Kobayashi	Added terminal number information.
	Date	Name	Third Angle Projection	Tolerance
Drawn	16.Jan.2006	I.Miyahara	Dimension:mm	Scale
Designed	16.Jan.2006	I.Miyahara	Title	Drawing No.
Checked	16.Jan.2006	---	Crystal Holder Marking	EXH11B-00317
Approved	16.Jan.2006	K.Okamoto		
				D

NIHON DEMPA KOGYO CO., LTD.

Reliability assurance item

(page: 1/1)

No.	Test Item	Test Methods	Specification Code
1	High Temperature Storage	+85±3°C 720h	A
2	Low Temperature Storage	-40±3°C 500h	A
3	Temperature Humidity	+60±3°C 90~95%RH 500h	A
4	Temperature Cycling	-40±3°C / +85±3°C It is 500 cycles using 30 minutes each as 1 cycle.	A
5	Vibration	Frequency Range : 10~55Hz Amplitude : 1.52mm 1 cycle : 1 minutes Test time : Three mutually perpendicular axes each 2 hours.	A
6	Shock	Devices are shocked to half sine wave (981m/s ²) three mutually perpendicular axis each 3 times.	A
7	Drop	Devices are dropped from the height 75cm onto wooden block. (more than 30mm thickness.) Execution 3 times random drops	A
8	Solderability	Pre-heat temperature : +150±10°C Pre-heat time : 60~120s When the temperature of the specimen is reached at +215±3°C, it shall be left for 30±1sec. Peak temperature 240±5°C Material: Pb-free (Sn-3.0Ag-0.5Cu) Flux : Rosin resin methyl alcohol solvent (1 : 4)	B
9	Reflow resistance	Pre-heat temperature : +150~180°C Pre-heat time : 90±30s Heat temperature : more than +230°C Heat time : 30s±10s Peak temperature : +260±5°C Peak time : less than 10s	A

Specification code	Specification
A	$\Delta f/f \leq \pm 5$ ppm $\Delta Cl/Cl \leq \pm 15$ % or 5 Ω make use larger value
B	The electrodes should be covered by a new solder at least 90% of immersed area.

单击下面可查看定价，库存，交付和生命周期等信息

[>>NDK\(电波\)](#)

[>>点击查看相关商品](#)