

# On-Resistance Load Switch

## 5.5 V, 3.9 mΩ, 10 A

### NLPS22990, NLPS22990N

The NLPS22990 and NLPS22990N devices are 3.9 mΩ, single-channel load switches with controlled and adjustable turn ons and integrated PG indicators.

Each device is an N-channel MOSFET operating over an input voltage range of 0.6 V to 5.5 V. The switch supports a maximum continuous current of 10 A. 3.9 mΩ switch on resistance minimizes both the voltage drop across the load switch and the power loss from the load switch.

Controlled rise time of the device switch reduces inrush currents caused by large bulk load capacitances, thereby reducing or eliminating power supply droop. Adjustable slew rate through CT provides the design flexibility to trade off inrush current and power up timing requirements. Integrated PG indicator notifies the system about the status of the load switch to facilitate seamless power sequencing.

The NLPS22990 has a 200-Ω On-chip resistor for quick discharge of the output when switch is disabled. This avoids unknown state caused by floating supply to the downstream load.

#### Features

- Integrated Single Channel Load Switch
- V<sub>BIAS</sub> Voltage Range: 2.5 V to 5.5 V
- V<sub>IN</sub> Voltage Range: 0.6 V to V<sub>BIAS</sub>
- On-Resistance
  - ◆ R<sub>ON</sub> = 3.9 mΩ (typical) at V<sub>IN</sub> = 5 V (V<sub>BIAS</sub> = 5 V)
  - ◆ R<sub>ON</sub> = 3.9 mΩ (typical) at V<sub>IN</sub> = 3.3 V (V<sub>BIAS</sub> = 3.3 V)
- 10-A Maximum Continuous Switch Current
- Quiescent Current
  - ◆ I<sub>Q,VBIAS</sub> = 85 μA at V<sub>BIAS</sub> = 5 V
- Shutdown Current
  - ◆ I<sub>SD,VBIAS</sub> = 0.3 μA at V<sub>BIAS</sub> = 5 V
  - ◆ I<sub>SD,VIN</sub> = 1.3 μA at V<sub>BIAS</sub> = 5 V, V<sub>IN</sub> = 5 V
- Controlled and Adjustable Slew Rate through CT
- Power Good (PG) Indicator
- Quick Output Discharge (QOD) (NLPS22990 Only)
- 3-mm x 2-mm WQFN 10-pin Package with Thermal Pad
- ESD Performance Tested per JESD 22
  - ◆ 2 kV HBM and 1 kV CDM

#### Applications

- Notebooks, Chromebooks and Tablets
- Desktop PC and Industrial PC
- Solid State Drives (SSDs)
- Servers
- Telecom Systems



ON Semiconductor®

[www.onsemi.com](http://www.onsemi.com)

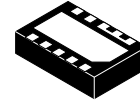

WDFN10  
MN SUFFIX  
CASE 511DX

#### MARKING DIAGRAM

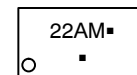

22A = Specific Device Code  
M = Date Code  
▪ = Pb-Free Package

(Note: Microdot may be in either location)

#### ORDERING INFORMATION

Device	Package	Shipping†
NLPS22990MN1TAG	WDFN10 (Pb-Free)	3000 / Tape & Reel
NLPS22990NMN1TAG (In development)		

†For information on tape and reel specifications, including part orientation and tape sizes, please refer to our Tape and Reel Packaging Specification Brochure, BRD8011/D.

# NLPS22990, NLPS22990N

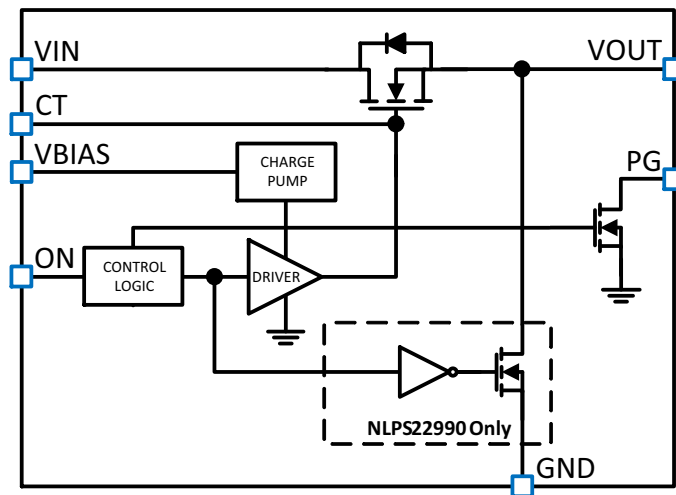

Figure 1. Block Diagram

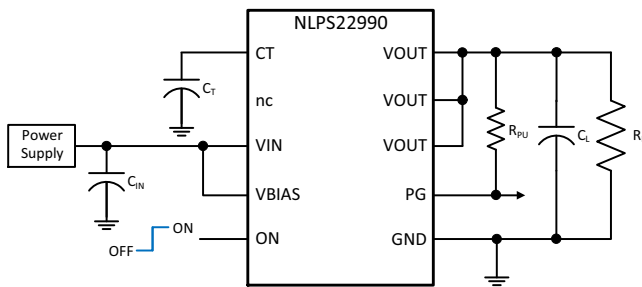

Figure 2. Typical Application

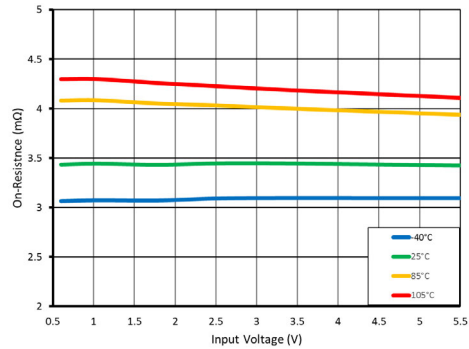

Figure 3. On Resistance vs. Input Voltage

## DEVICE COMPARISON

Device	$R_{ON}$ at $V_{BIAS} = 5\text{ V}$	$I_{MAX}$	ENABLE	QOD
NLPS22990	3.9 mΩ	10 A	Active High	Yes
NLPS22990N	3.9 mΩ	10 A	Active High	No

## NLPS22990, NLPS22990N

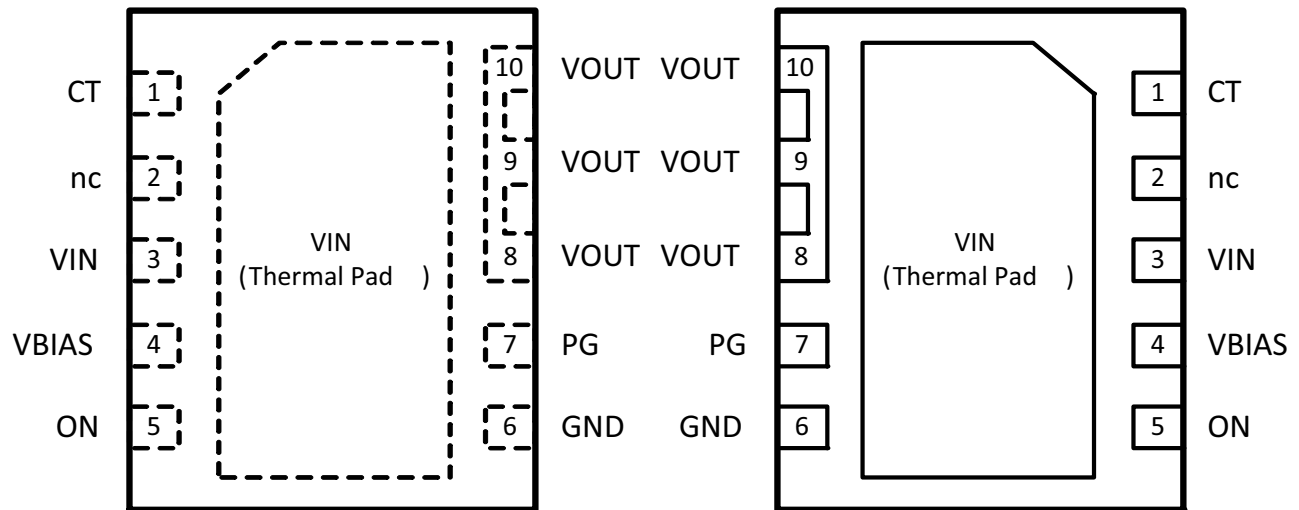

Figure 4. WDFN10 Pin Assignment

Table 1. PIN DESCRIPTIONS

Pin Name	Pin	Pin Type	Description
CT	1	O	V <sub>OUT</sub> slew rate control.
nc	2	-	No connect.
V <sub>IN</sub>	3	I	Switch input. Bypass this input with a ceramic capacitor to GND.
V <sub>BIAS</sub>	4	P	Bias voltage. Power supply to the device.
ON	5	I	Active high switch control input. Do not leave floating.
GND	6	GND	Device ground.
PG	7	O	Power good. Active high open-drain output. Tie to GND if not used.
V <sub>OUT</sub>	8	O	Switch output.
	9		
	10		
V <sub>IN</sub>	Thermal Pad	I	Switch input. VIN and thermal pad (exposed center pad) to alleviate thermal stress. See the layout section for layout guidelines.

# NLPS22990, NLPS22990N

**Table 2. MAXIMUM RATINGS**

Symbol	Rating	Value	Unit
V <sub>BIAS</sub>	Bias Voltage	-0.3 to +6	V
V <sub>IN</sub>	Input Voltage	-0.3 to +6	V
V <sub>OUT</sub>	Output Voltage	-0.3 to +6	V
V <sub>ON</sub>	ON Voltage	-0.3 to +6	V
V <sub>PG</sub>	PG Voltage	-0.3 to +6	V
V <sub>CT</sub>	CT Voltage	-0.3 to +15	V
I <sub>MAX</sub>	Continuous Switch Current at T <sub>J</sub> = 125°C	10	A
I <sub>PLS</sub>	Pulsed Switch Current, Pulse < 300 μs 2% Duty Cycle	12	A
V <sub>IN</sub>	Digital Control Pin Voltage on EN, SEL	-0.5 to V <sub>CC</sub> +0.5	V
T <sub>s</sub>	Storage Temperature	-65 to +150	°C
T <sub>L</sub>	Lead Temperature, 1 mm from Case for 10 seconds	300	°C
T <sub>J</sub>	Junction Temperature	125	°C
MSL	Moisture Sensitivity (Note 1)	Level 1	
ESD	ESD Protection (Note 2)		V
	Human Body Model	±2000	
	Charged Device Model	±1000	

Stresses exceeding those listed in the Maximum Ratings table may damage the device. If any of these limits are exceeded, device functionality should not be assumed, damage may occur and reliability may be affected.

- Moisture Sensitivity Level (MSL): 1 per IPC/JEDEC standard: J-STD-020A.
- This device series contains ESD protection and passes the following tests:  
Human Body Model (HBM) ±2.0 kV per JEDEC standard: JESD22-A114.  
Charged Device Model (CDM) ±1000 V per JEDEC standard: JESD22-C101.

**Table 3. RECOMMENDED OPERATING CONDITIONS**

Symbol	Parameter	Min	Max	Unit
V <sub>BIAS</sub>	Bias Voltage	2.5	5.5	V
V <sub>IN</sub>	Input Voltage	0.6	V <sub>BIAS</sub>	V
V <sub>OUT</sub>	Output Voltage		V <sub>IN</sub>	V
V <sub>ON</sub>	ON Voltage	0	5.5	V
V <sub>PG</sub>	PG Voltage	0	5.5	V
C <sub>IN</sub>	Input Capacitor (Note 3)	1		μF
T <sub>A</sub>	Operating Temperature Range	-40	+105	°C

Functional operation above the stresses listed in the Recommended Operating Ranges is not implied. Extended exposure to stresses beyond the Recommended Operating Ranges limits may affect device reliability.

- See Application Information section.

**Table 4. THERMAL INFORMATION**

Symbol	Parameter	Value	Unit
R <sub>θJA</sub>	Junction to Ambient Thermal Resistance	51.4	°C/W
R <sub>θJC(top)</sub>	Junction to Case (top) Thermal Resistance	65	°C/W
R <sub>θJB</sub>	Junction to Board Thermal Resistance	17.4	°C/W
ψ <sub>JT</sub>	Junction to Top Characterization Parameter	2.1	°C/W
ψ <sub>JB</sub>	Junction to Bottom Characterization Parameter	17	°C/W
R <sub>θJC(bot)</sub>	Junction to Case (bottom) Thermal Resistance	3.7	°C/W

- See Application Information section.

# NLPS22990, NLPS22990N

**Table 5. DC ELECTRICAL CHARACTERISTICS** (Typical values are at  $T_A = +25^\circ\text{C}$ , unless otherwise noted.)

Symbol	Parameter	Test Conditions	$V_{BIAS}$ (V)	-40°C to 85°C			-40°C to 105°C		Unit
				Min	Typ	Max	Min	Max	
<b>ON PIN</b>									
$V_{IH}$	Input Voltage High		5, 3.3	1.0	-	5.5	1.0	5.5	V
$V_{IL}$	Input Voltage Low		5, 3.3	0	-	0.5	0	0.5	V
$V_{HYS}$	Hysteresis Voltage		5	-	99	-	-	-	mV
				3.3	-	128	-	-	
$I_{ON,LKG}$	Input Leakage Current		5, 3.3	-	-	0.1	-	0.1	$\mu\text{A}$
<b>PG PIN</b>									
$V_{OL}$	Output Voltage Low	$V_{ON} = 0\text{ V}$ , $I_{PG} = 1\text{ mA}$	5, 3.3	-	-	0.2	-	0.2	V
$I_{PG,LKG}$	Leakage Current into Pin	$V_{PG} = 5\text{ V}$	5, 3.3	-	-	0.5	-	0.5	$\mu\text{A}$
<b>POWER SUPPLY AND OTHER CURRENTS</b>									
$I_{Q,VBIAS}$	$V_{BIAS}$ Quiescent Current	$I_{OUT} = 0\text{ A}$ , $V_{IN} = V_{ON} = 5\text{ V}$ $V_{IN} = V_{ON} = 3.3\text{ V}$	5	-	85	100	-	100	$\mu\text{A}$
				3.3	-	63	80	-	
$I_{SD,VBIAS}$	$V_{BIAS}$ Shutdown Current	$V_{ON} = 0\text{ V}$ , $V_{OUT} = 0\text{ V}$	5	-	0.3	7	-	7	$\mu\text{A}$
				3.3	-	0.3	6	-	
$I_{SD,VIN}$	$V_{IN}$ Shutdown Current	$V_{ON} = 0\text{ V}$ , $V_{OUT} = 0\text{ V}$ , $V_{IN} = 5\text{ V}$ $V_{IN} = 3.3\text{ V}$ $V_{IN} = 2.5\text{ V}$ $V_{IN} = 1.8\text{ V}$ $V_{IN} = 1.05\text{ V}$ $V_{IN} = 0.6\text{ V}$	5	-	1.3	4	-	10	$\mu\text{A}$
				-	0.8	3	-	7	
				-	0.6	2	-	5	
				-	0.5	2	-	4	
				-	0.4	1	-	3	
				-	0.2	1	-	2	
		$V_{ON} = 0\text{ V}$ , $V_{OUT} = 0\text{ V}$ , $V_{IN} = 3.3\text{ V}$ $V_{IN} = 2.5\text{ V}$ $V_{IN} = 1.8\text{ V}$ $V_{IN} = 1.05\text{ V}$ $V_{IN} = 0.6\text{ V}$	3.3	-	0.8	3	-	7	$\mu\text{A}$
				-	0.6	2	-	5	
				-	0.5	2	-	4	
				-	0.3	1	-	3	
				-	0.2	1	-	2	
				-	0.2	1	-	2	

Product parametric performance is indicated in the Electrical Characteristics for the listed test conditions, unless otherwise noted. Product performance may not be indicated by the Electrical Characteristics if operated under different conditions.

# NLPS22990, NLPS22990N

**Table 6. LOAD SWITCH RESISTANCE** (Typical values are at  $T_A = +25^\circ\text{C}$ , unless otherwise noted.)

Symbol	Parameter	Test Conditions	$V_{\text{BIAS}}$ (V)	25°C			-40°C to 85°C	-40°C to 105°C	Unit	
				Min	Typ	Max	Max	Max		
$R_{\text{ON}}$	On-State Resistance	$V_{\text{ON}} = 5\text{ V}$ , $I_{\text{OUT}} = -200\text{ mA}$ $V_{\text{IN}} = 5\text{ V}$ $V_{\text{IN}} = 3.3\text{ V}$ $V_{\text{IN}} = 2.5\text{ V}$ $V_{\text{IN}} = 1.8\text{ V}$ $V_{\text{IN}} = 1.05\text{ V}$ $V_{\text{IN}} = 0.6\text{ V}$	5							mΩ
				-	3.9	4.8	5.7	6		
				-	3.9	4.8	5.7	6		
				-	3.9	4.8	5.7	6		
				-	3.9	4.8	5.7	6		
				-	3.9	4.8	5.7	6		
				-	3.9	4.8	5.7	6		
								mΩ		
		$V_{\text{ON}} = 5\text{ V}$ , $I_{\text{OUT}} = -200\text{ mA}$ $V_{\text{IN}} = 3.3\text{ V}$ $V_{\text{IN}} = 2.5\text{ V}$ $V_{\text{IN}} = 1.8\text{ V}$ $V_{\text{IN}} = 1.05\text{ V}$ $V_{\text{IN}} = 0.6\text{ V}$	3.3	-	3.9	4.8	5.7		6	
				-	3.9	4.8	5.7		6	
				-	3.9	4.8	5.7		6	
				-	3.9	4.8	5.7		6	
				-	3.9	4.8	5.7		6	
				-	3.9	4.8	5.7		6	
-	3.9			4.8	5.7	6				

**Table 7. OUTPUT PULL-DOWN RESISTANCE (NLPS22990 Only)** (Typical values are at  $T_A = +25^\circ\text{C}$ , unless otherwise noted.)

Symbol	Parameter	Test Conditions	$V_{\text{BIAS}}$ (V)	-40°C to 105°C			Unit
				Min	Typ	Max	
$R_{\text{PD}}$	Output Pulldown Resistance	$V_{\text{ON}} = 0\text{ V}$ , $V_{\text{IN}} = V_{\text{OUT}} = 5\text{ V}$	5	-	197	280	Ω
		$V_{\text{ON}} = 0\text{ V}$ , $V_{\text{IN}} = V_{\text{OUT}} = 3.3\text{ V}$	3.3	-	204	280	

# NLPS22990, NLPS22990N

**Table 8. SWITCHING CHARACTERISTICS** (Typical values are at  $T_A = +25^\circ\text{C}$ , unless otherwise noted.)

Symbol <sup>4</sup>	Parameter	Test Conditions	V <sub>BIAS</sub> (V)	Min	Typ	Max	Unit
t <sub>ON</sub>	Turn-On Time	V <sub>IN</sub> = 5 V, V <sub>ON</sub> = V <sub>BIAS</sub> , R <sub>L</sub> = 10 Ω, C <sub>L</sub> = 0.1 μF, C <sub>T</sub> = 0 pF, R <sub>PU</sub> = 10 kΩ, C <sub>IN</sub> = 1 μF	5	-	24	-	μs
t <sub>OFF</sub>	Turn-Off Time			-	6	-	
t <sub>R</sub>	V <sub>OUT</sub> Rise Time			-	31	-	
t <sub>F</sub>	V <sub>OUT</sub> Fall Time			-	2.9	-	
t <sub>D</sub>	ON Delay Time			-	13	-	
t <sub>PG,ON</sub>	PG Turn-On Time			-	119	-	
t <sub>PG,OFF</sub>	PG Turn-Off Time			-	0.15	-	
t <sub>ON</sub>	Turn-On Time	V <sub>IN</sub> = 1.05 V, V <sub>ON</sub> = V <sub>BIAS</sub> , R <sub>L</sub> = 10 Ω, C <sub>L</sub> = 0.1 μF, C <sub>T</sub> = 0 pF, R <sub>PU</sub> = 10 kΩ, C <sub>IN</sub> = 1 μF	5	-	23	-	μs
t <sub>OFF</sub>	Turn-Off Time			-	12	-	
t <sub>R</sub>	V <sub>OUT</sub> Rise Time			-	16	-	
t <sub>F</sub>	V <sub>OUT</sub> Fall Time			-	4.0	-	
t <sub>D</sub>	ON Delay Time			-	16	-	
t <sub>PG,ON</sub>	PG Turn-On Time			-	97	-	
t <sub>PG,OFF</sub>	PG Turn-Off Time			-	0.15	-	
t <sub>ON</sub>	Turn-On Time	V <sub>IN</sub> = 0.6 V, V <sub>ON</sub> = V <sub>BIAS</sub> , R <sub>L</sub> = 10 Ω, C <sub>L</sub> = 0.1 μF, C <sub>T</sub> = 0 pF, R <sub>PU</sub> = 10 kΩ, C <sub>IN</sub> = 1 μF	5	-	24	-	μs
t <sub>OFF</sub>	Turn-Off Time			-	13.5	-	
t <sub>R</sub>	V <sub>OUT</sub> Rise Time			-	11.7	-	
t <sub>F</sub>	V <sub>OUT</sub> Fall Time			-	3.8	-	
t <sub>D</sub>	ON Delay Time			-	18	-	
t <sub>PG,ON</sub>	PG Turn-On Time			-	95	-	
t <sub>PG,OFF</sub>	PG Turn-Off Time			-	0.15	-	
t <sub>ON</sub>	Turn-On Time	V <sub>IN</sub> = 3.3 V, V <sub>ON</sub> = 5 V, R <sub>L</sub> = 10 Ω, C <sub>L</sub> = 0.1 μF, C <sub>T</sub> = 0 pF, R <sub>PU</sub> = 10 kΩ, C <sub>IN</sub> = 1 μF	3.3	-	29	-	μs
t <sub>OFF</sub>	Turn-Off Time			-	7.4	-	
t <sub>R</sub>	V <sub>OUT</sub> Rise Time			-	29	-	
t <sub>F</sub>	V <sub>OUT</sub> Fall Time			-	3.3	-	
t <sub>D</sub>	ON Delay Time			-	18	-	
t <sub>PG,ON</sub>	PG Turn-On Time			-	112	-	
t <sub>PG,OFF</sub>	PG Turn-Off Time			-	0.21	-	
t <sub>ON</sub>	Turn-On Time	V <sub>IN</sub> = 1.05 V, V <sub>ON</sub> = 5 V, R <sub>L</sub> = 10 Ω, C <sub>L</sub> = 0.1 μF, C <sub>T</sub> = 0 pF, R <sub>PU</sub> = 10 kΩ, C <sub>IN</sub> = 1 μF	3.3	-	30	-	μs
t <sub>OFF</sub>	Turn-Off Time			-	11	-	
t <sub>R</sub>	V <sub>OUT</sub> Rise Time			-	18.5	-	
t <sub>F</sub>	V <sub>OUT</sub> Fall Time			-	4.0	-	
t <sub>D</sub>	ON Delay Time			-	22	-	
t <sub>PG,ON</sub>	PG Turn-On Time			-	101	-	
t <sub>PG,OFF</sub>	PG Turn-Off Time			-	0.21	-	
t <sub>ON</sub>	Turn-On Time	V <sub>IN</sub> = 0.6 V, V <sub>ON</sub> = 5 V, R <sub>L</sub> = 10 Ω, C <sub>L</sub> = 0.1 μF, C <sub>T</sub> = 0 pF, R <sub>PU</sub> = 10 kΩ, C <sub>IN</sub> = 1 μF	3.3	-	31	-	μs
t <sub>OFF</sub>	Turn-Off Time			-	13	-	
t <sub>R</sub>	V <sub>OUT</sub> Rise Time			-	14	-	
t <sub>F</sub>	V <sub>OUT</sub> Fall Time			-	3.8	-	
t <sub>D</sub>	ON Delay Time			-	25	-	
t <sub>PG,ON</sub>	PG Turn-On Time			-	99	-	
t <sub>PG,OFF</sub>	PG Turn-Off Time			-	0.21	-	

5. Turn-off time and fall time are dependent on the time constant at the load. For NLPS22990N, there is no QOD. The time constant is  $R_L \times C_L$ . For NLPS22990, internal pull down R<sub>PD</sub> is enabled when the switch is disabled. The time constant is  $(R_{PD}/R_L) \times C_L$ .

Typical Characteristics

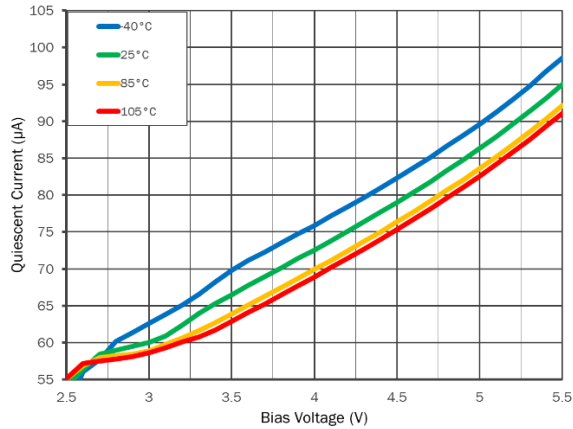

$V_{ON} = 5\text{ V}, I_{OUT} = 0\text{ A}, V_{IN} = V_{BIAS}$

Figure 5. Quiescent Current vs. Bias Voltage

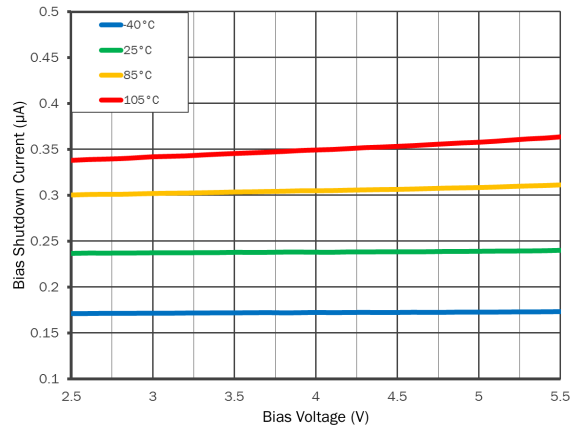

$V_{ON} = 0\text{ V}, V_{OUT} = 0\text{ V}, V_{IN} = V_{BIAS}$

Figure 6. Bias Shutdown Current vs. Bias Voltage

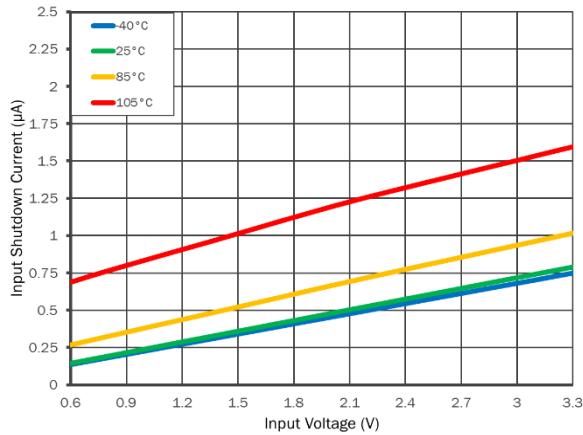

$V_{ON} = 0\text{ V}, V_{BIAS} = 3.3\text{ V}, V_{OUT} = 0\text{ V}$

Figure 7. Input Shutdown Current vs. Input Voltage

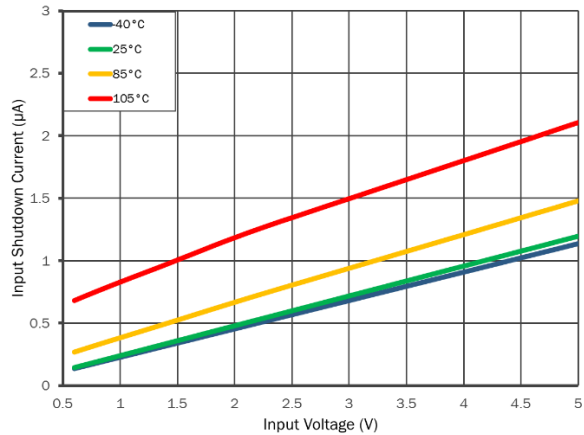

$V_{ON} = 0\text{ V}, V_{BIAS} = 5\text{ V}, V_{OUT} = 0\text{ V}$

Figure 8. Input Shutdown Current vs. Input Voltage

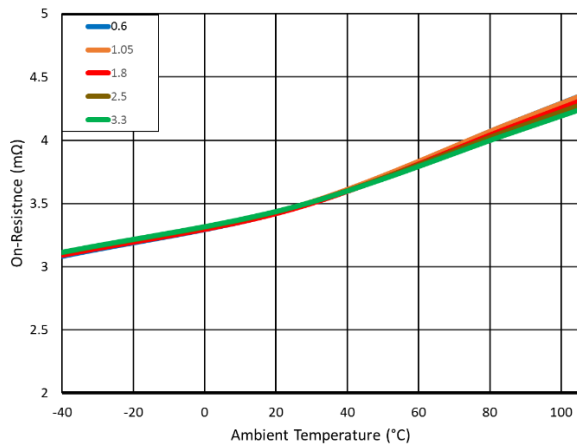

$V_{ON} = 5\text{ V}, V_{BIAS} = 3.3\text{ V}, I_{OUT} = -200\text{ mA}$

Figure 9. On-Resistance vs. Ambient Temperature

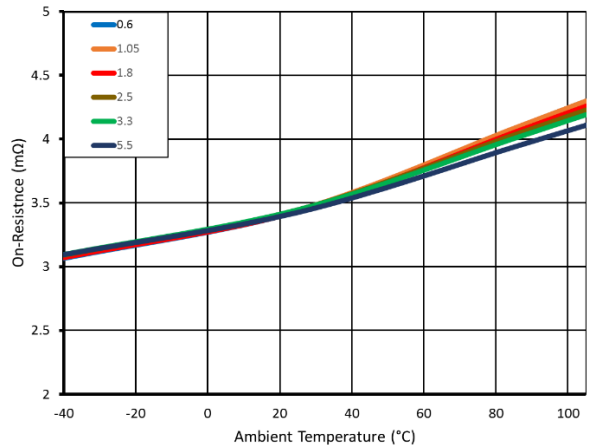

$V_{ON} = 5\text{ V}, V_{BIAS} = 5\text{ V}, I_{OUT} = -200\text{ mA}$

Figure 10. On-Resistance vs. Ambient Temperature



Typical Characteristics

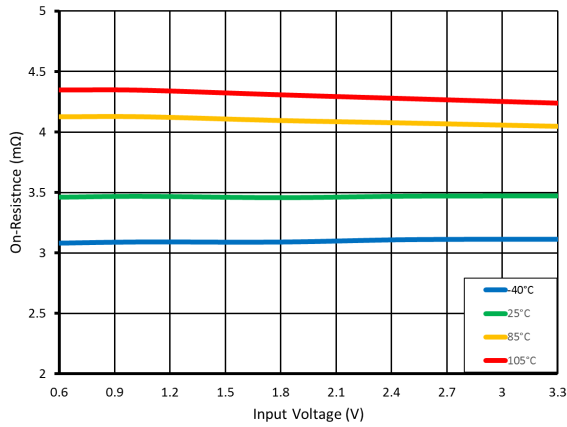

$V_{ON} = 5\text{ V}$ ,  $V_{BIAS} = 3.3\text{ V}$ ,  $I_{OUT} = -200\text{ mA}$

Figure 11. On-Resistance vs. Input Voltage

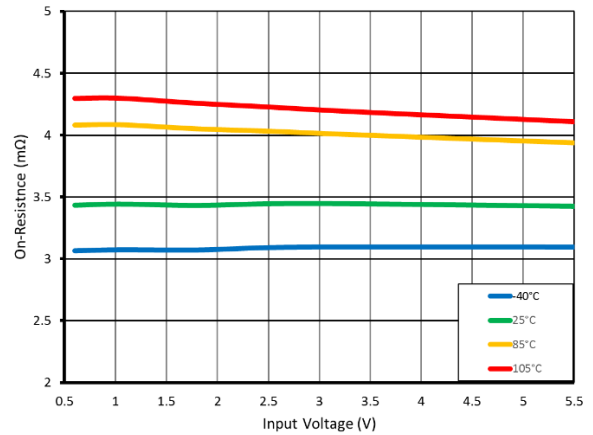

$V_{ON} = 5\text{ V}$ ,  $V_{BIAS} = 5\text{ V}$ ,  $I_{OUT} = -200\text{ mA}$

Figure 12. On-Resistance vs. Input Voltage

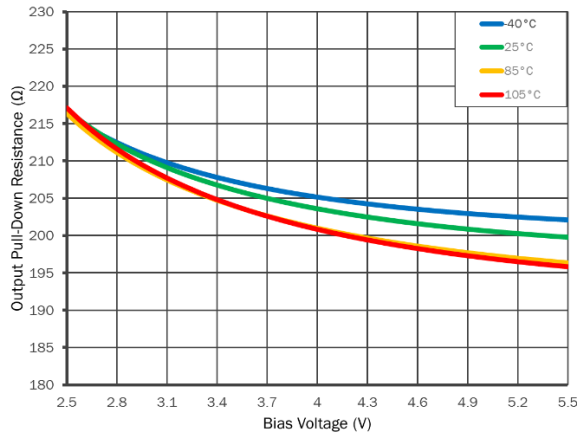

$V_{ON} = 0\text{ V}$ ,  $V_{OUT} = V_{IN} = 1.05\text{ V}$

Figure 13. Output Pull-Down Resistance vs. Bias Voltage

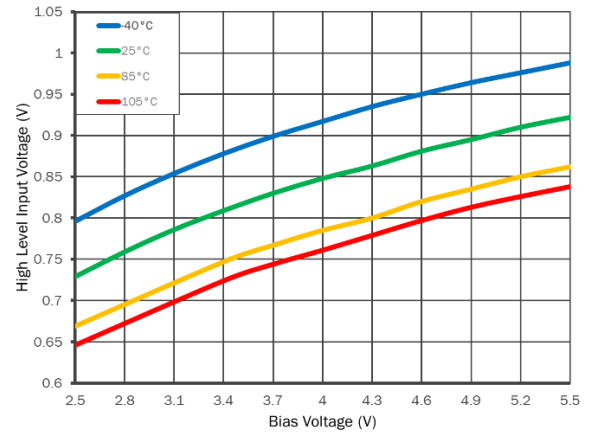

$I_{OUT} = 0\text{ A}$

Figure 14. High-Level Input Voltage vs. Bias Voltage

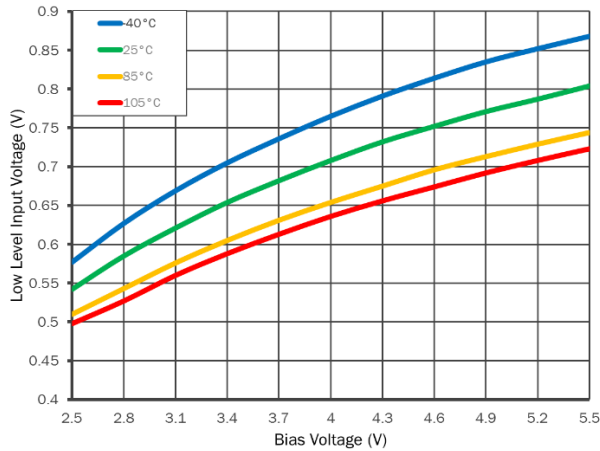

$I_{OUT} = 0\text{ A}$

Figure 15. Low-Level Input Voltage vs. Bias Voltage

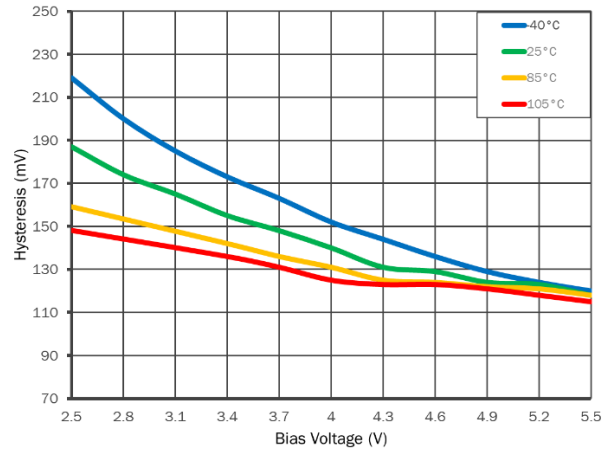

$I_{OUT} = 0\text{ A}$

Figure 16. Hysteresis vs. Bias Voltage

Typical Characteristics

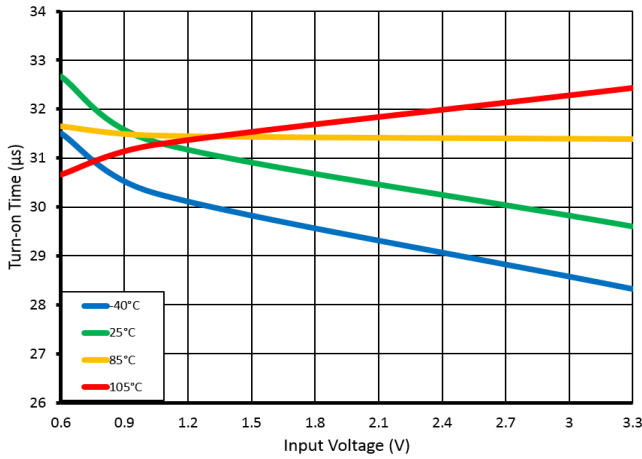

$V_{BIAS} = 3.3\text{ V}$ ,  $V_{ON} = 5\text{ V}$ ,  $C_T = 0\text{ pF}$ ,  
 $C_{IN} = 1\text{ }\mu\text{F}$ ,  $C_L = 0.1\text{ }\mu\text{F}$ ,  $R_L = 10\text{ }\Omega$

Figure 17. Turn-on Time vs. Input Voltage

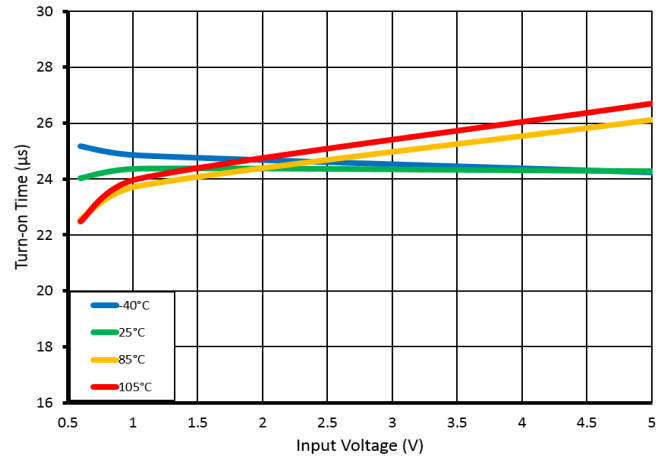

$V_{BIAS} = 5\text{ V}$ ,  $V_{ON} = 5\text{ V}$ ,  $C_T = 0\text{ pF}$ ,  
 $C_{IN} = 1\text{ }\mu\text{F}$ ,  $C_L = 0.1\text{ }\mu\text{F}$ ,  $R_L = 10\text{ }\Omega$

Figure 18. Turn-on Time vs. Input Voltage

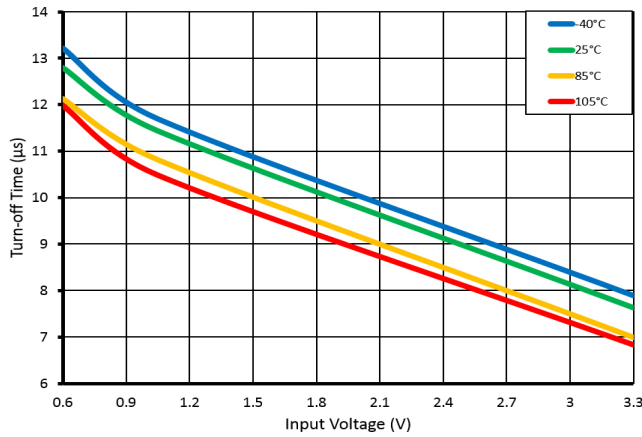

$V_{BIAS} = 3.3\text{ V}$ ,  $V_{ON} = 5\text{ V}$ ,  $C_T = 0\text{ pF}$ ,  
 $C_{IN} = 1\text{ }\mu\text{F}$ ,  $C_L = 0.1\text{ }\mu\text{F}$ ,  $R_L = 10\text{ }\Omega$

Figure 19. Turn-off Time vs. Input Voltage

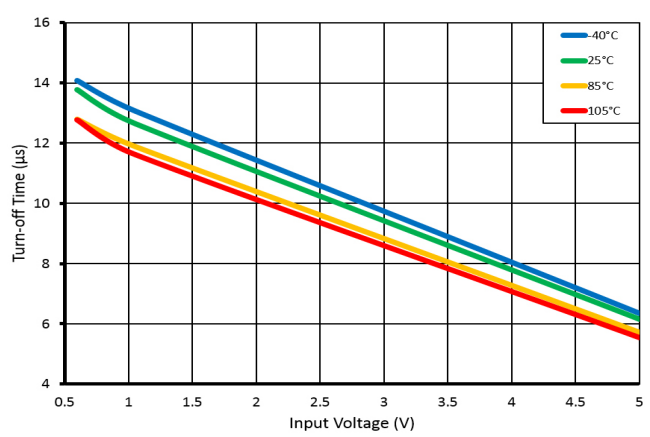

$V_{BIAS} = 5\text{ V}$ ,  $V_{ON} = 5\text{ V}$ ,  $C_T = 0\text{ pF}$ ,  
 $C_{IN} = 1\text{ }\mu\text{F}$ ,  $C_L = 0.1\text{ }\mu\text{F}$ ,  $R_L = 10\text{ }\Omega$

Figure 20. Turn-off Time vs. Input Voltage

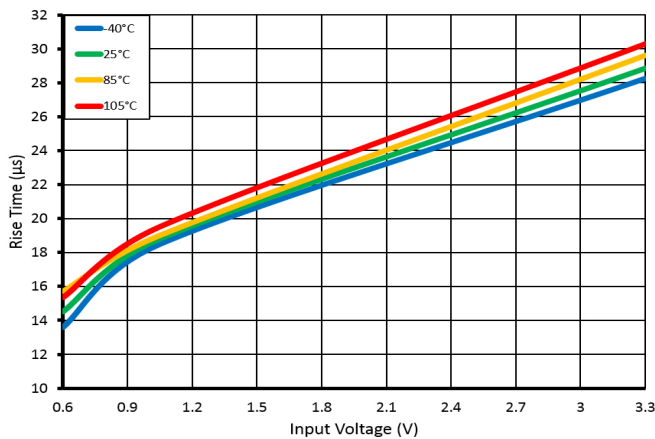

$V_{BIAS} = 3.3\text{ V}$ ,  $V_{ON} = 5\text{ V}$ ,  $C_T = 0\text{ pF}$ ,  
 $C_{IN} = 1\text{ }\mu\text{F}$ ,  $C_L = 0.1\text{ }\mu\text{F}$ ,  $R_L = 10\text{ }\Omega$

Figure 21. Rise Time vs. Input Voltage

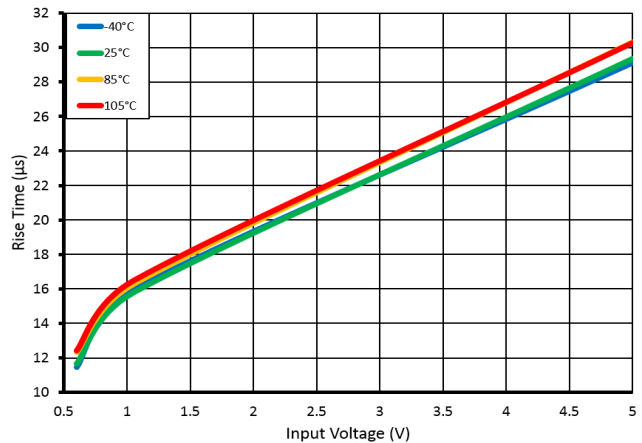

$V_{BIAS} = 5\text{ V}$ ,  $V_{ON} = 5\text{ V}$ ,  $C_T = 0\text{ pF}$ ,  
 $C_{IN} = 1\text{ }\mu\text{F}$ ,  $C_L = 0.1\text{ }\mu\text{F}$ ,  $R_L = 10\text{ }\Omega$

Figure 22. Rise Time vs. Input Voltage

Typical Characteristics

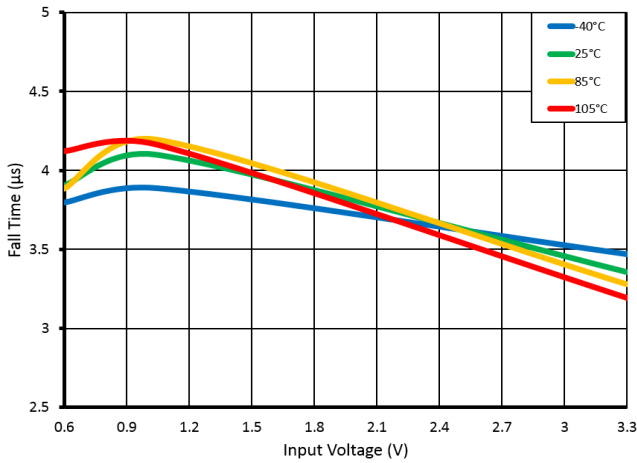

$V_{BIAS} = 3.3\text{ V}$ ,  $V_{ON} = 5\text{ V}$ ,  $C_T = 0\text{ pF}$ ,  
 $C_{IN} = 1\text{ }\mu\text{F}$ ,  $C_L = 0.1\text{ }\mu\text{F}$ ,  $R_L = 10\text{ }\Omega$   
**Figure 23. Fall Time vs. Input Voltage**

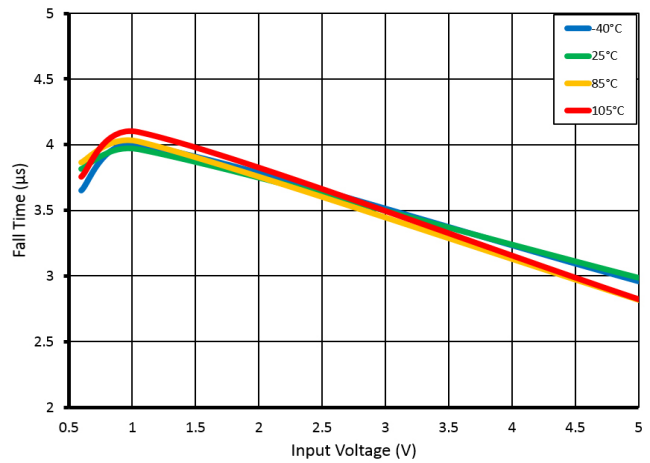

$V_{BIAS} = 5\text{ V}$ ,  $V_{ON} = 5\text{ V}$ ,  $C_T = 0\text{ pF}$ ,  
 $C_{IN} = 1\text{ }\mu\text{F}$ ,  $C_L = 0.1\text{ }\mu\text{F}$ ,  $R_L = 10\text{ }\Omega$   
**Figure 24. Fall Time vs. Input Voltage**

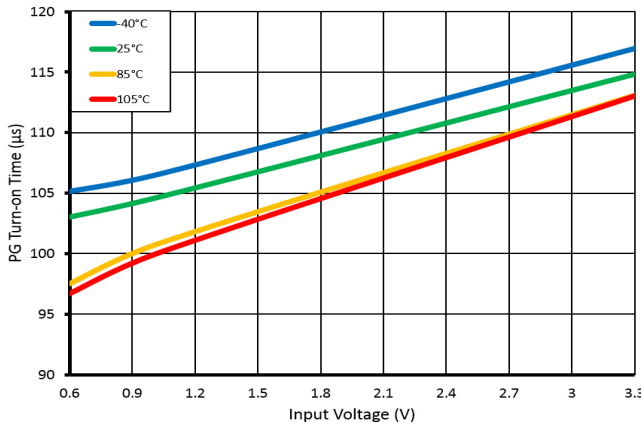

$V_{BIAS} = 3.3\text{ V}$ ,  $V_{ON} = 5\text{ V}$ ,  $C_T = 0\text{ pF}$ ,  
 $R_{PU} = 10\text{ k}\Omega$ ,  $C_L = 0.1\text{ }\mu\text{F}$ ,  $R_L = 10\text{ }\Omega$   
**Figure 25. PG Turn-on Time vs. Input Voltage**

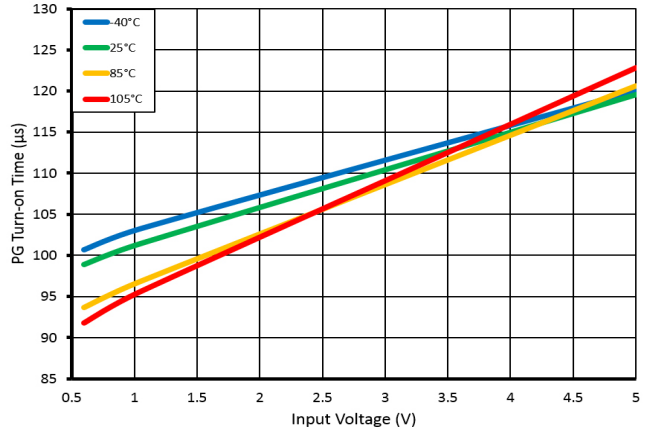

$V_{BIAS} = 5\text{ V}$ ,  $V_{ON} = 5\text{ V}$ ,  $C_T = 0\text{ pF}$ ,  
 $R_{PU} = 10\text{ k}\Omega$ ,  $C_L = 0.1\text{ }\mu\text{F}$ ,  $R_L = 10\text{ }\Omega$   
**Figure 26. PG Turn-on Time vs. Input Voltage**

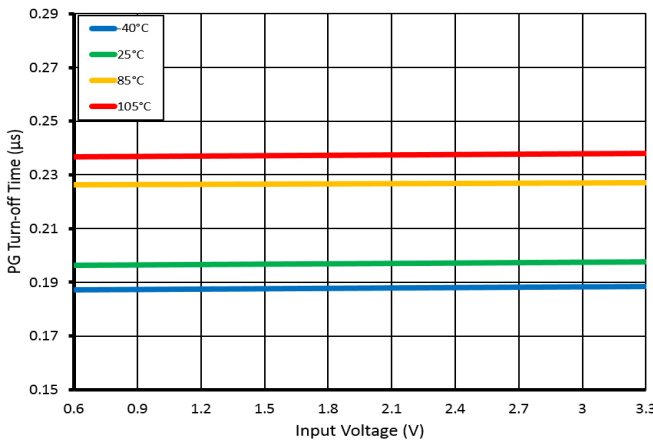

$V_{BIAS} = 3.3\text{ V}$ ,  $V_{ON} = 5\text{ V}$ ,  $C_T = 0\text{ pF}$ ,  
 $R_{PU} = 10\text{ k}\Omega$ ,  $C_L = 0.1\text{ }\mu\text{F}$ ,  $R_L = 10\text{ }\Omega$   
**Figure 27. PG Turn-off vs. Input Voltage**

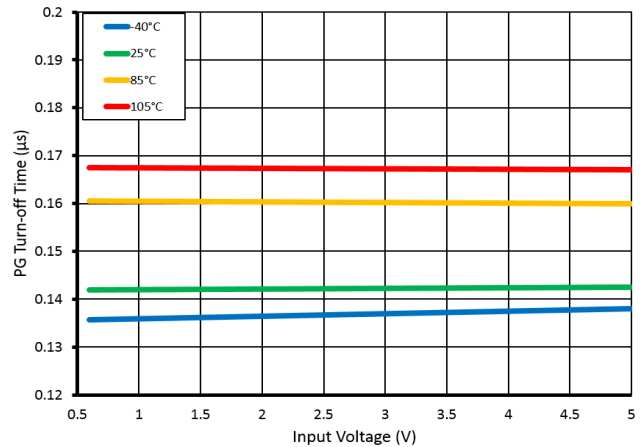

$V_{BIAS} = 5\text{ V}$ ,  $V_{ON} = 5\text{ V}$ ,  $C_T = 0\text{ pF}$ ,  
 $R_{PU} = 10\text{ k}\Omega$ ,  $C_L = 0.1\text{ }\mu\text{F}$ ,  $R_L = 10\text{ }\Omega$   
**Figure 28. PG Turn-off Time vs. Input Voltage**

# NLPS22990, NLPS22990N

## Typical Characteristics

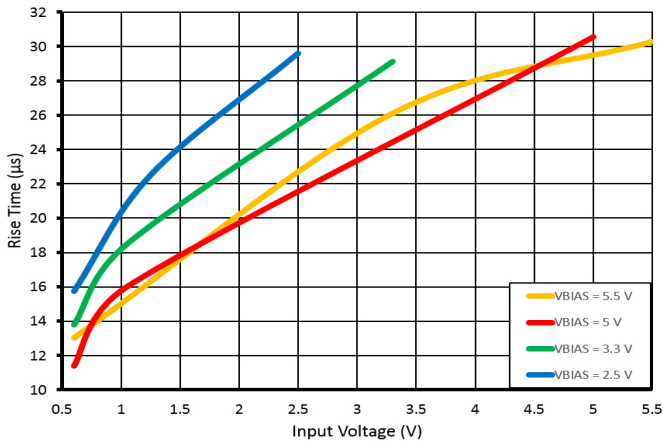

$T_A = 25\text{ }^\circ\text{C}$ ,  $C_L = 0.1\text{ }\mu\text{F}$ ,  $C_T = 0\text{ pF}$ ,  
 $C_{IN} = 1\text{ }\mu\text{F}$ ,  $R_L = 10\text{ }\Omega$

Figure 29. Rise Time vs. Input Voltage

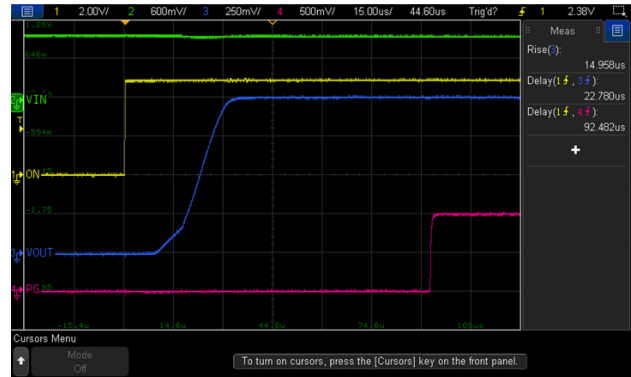

$V_{BIAS} = 5\text{ V}$ ,  $V_{IN} = 1.05\text{ V}$ ,  $C_T = 0\text{ pF}$ ,  
 $C_{IN} = 1\text{ }\mu\text{F}$ ,  $C_L = 0.1\text{ }\mu\text{F}$ ,  $R_L = 10\text{ }\Omega$

Figure 30. Turn-on Response

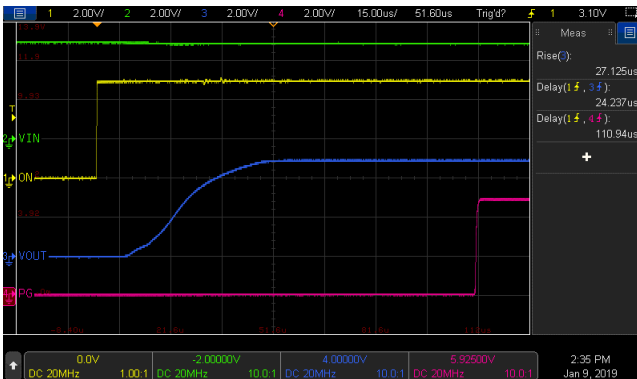

$V_{BIAS} = 5\text{ V}$ ,  $V_{IN} = 5\text{ V}$ ,  $C_T = 0\text{ pF}$ ,  
 $C_{IN} = 1\text{ }\mu\text{F}$ ,  $C_L = 0.1\text{ }\mu\text{F}$ ,  $R_L = 10\text{ }\Omega$

Figure 31. Turn-on Response

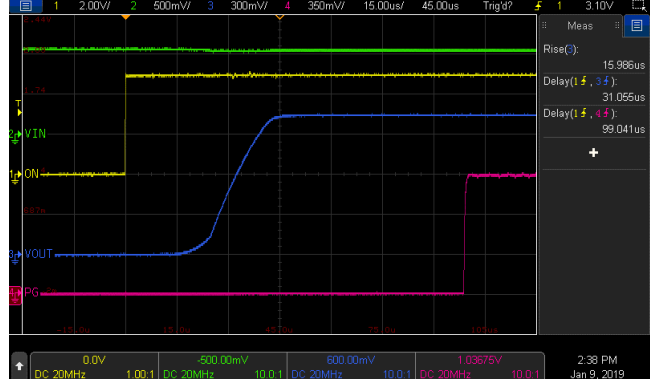

$V_{BIAS} = 3.3\text{ V}$ ,  $V_{IN} = 1.05\text{ V}$ ,  $C_T = 0\text{ pF}$ ,  
 $C_{IN} = 1\text{ }\mu\text{F}$ ,  $C_L = 0.1\text{ }\mu\text{F}$ ,  $R_L = 10\text{ }\Omega$

Figure 32. Turn-on Response

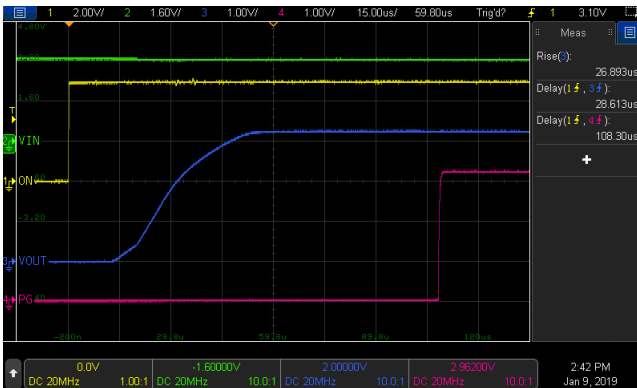

$V_{BIAS} = 3.3\text{ V}$ ,  $V_{IN} = 3.3\text{ V}$ ,  $C_T = 0\text{ pF}$ ,  
 $C_{IN} = 1\text{ }\mu\text{F}$ ,  $C_L = 0.1\text{ }\mu\text{F}$ ,  $R_L = 10\text{ }\Omega$

Figure 33. Turn-on Response

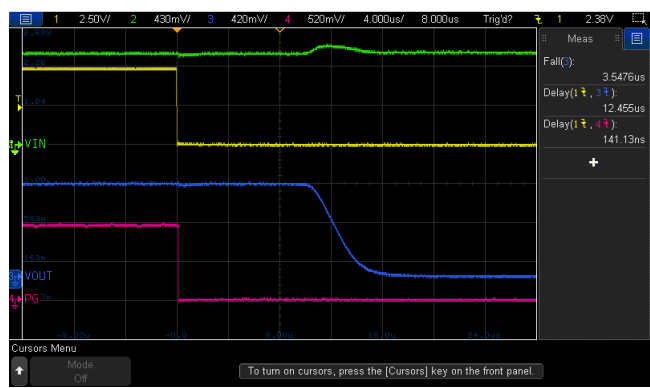

$V_{BIAS} = 5\text{ V}$ ,  $V_{IN} = 1.05\text{ V}$ ,  $C_T = 0\text{ pF}$ ,  
 $C_{IN} = 1\text{ }\mu\text{F}$ ,  $C_L = 0.1\text{ }\mu\text{F}$ ,  $R_L = 10\text{ }\Omega$

Figure 34. Turn-on Response

# NLPS2290, NLPS2290N

## Typical Characteristics

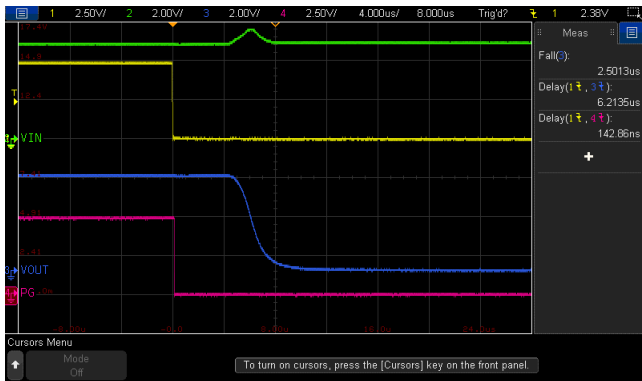

$V_{BIAS} = 5\text{ V}$ ,  $V_{IN} = 5\text{ V}$ ,  $C_T = 0\text{ pF}$ ,  
 $C_{IN} = 1\text{ }\mu\text{F}$ ,  $C_L = 0.1\text{ }\mu\text{F}$ ,  $R_L = 10\text{ }\Omega$

**Figure 35. Turn-off Response**

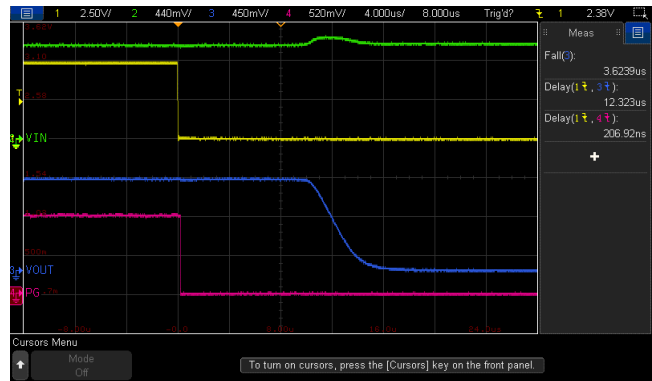

$V_{BIAS} = 3.3\text{ V}$ ,  $V_{IN} = 1.05\text{ V}$ ,  $C_T = 0\text{ pF}$ ,  
 $C_{IN} = 1\text{ }\mu\text{F}$ ,  $C_L = 0.1\text{ }\mu\text{F}$ ,  $R_L = 10\text{ }\Omega$

**Figure 36. Turn-off Response**

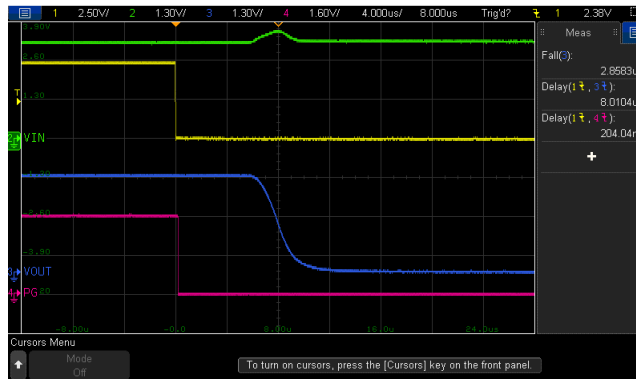

$V_{BIAS} = 3.3\text{ V}$ ,  $V_{IN} = 3.3\text{ V}$ ,  $C_T = 0\text{ pF}$ ,  
 $C_{IN} = 1\text{ }\mu\text{F}$ ,  $C_L = 0.1\text{ }\mu\text{F}$ ,  $R_L = 10\text{ }\Omega$

**Figure 37. Turn-off Response**

# NLPS22990, NLPS22990N

## Parameter Measurement Information

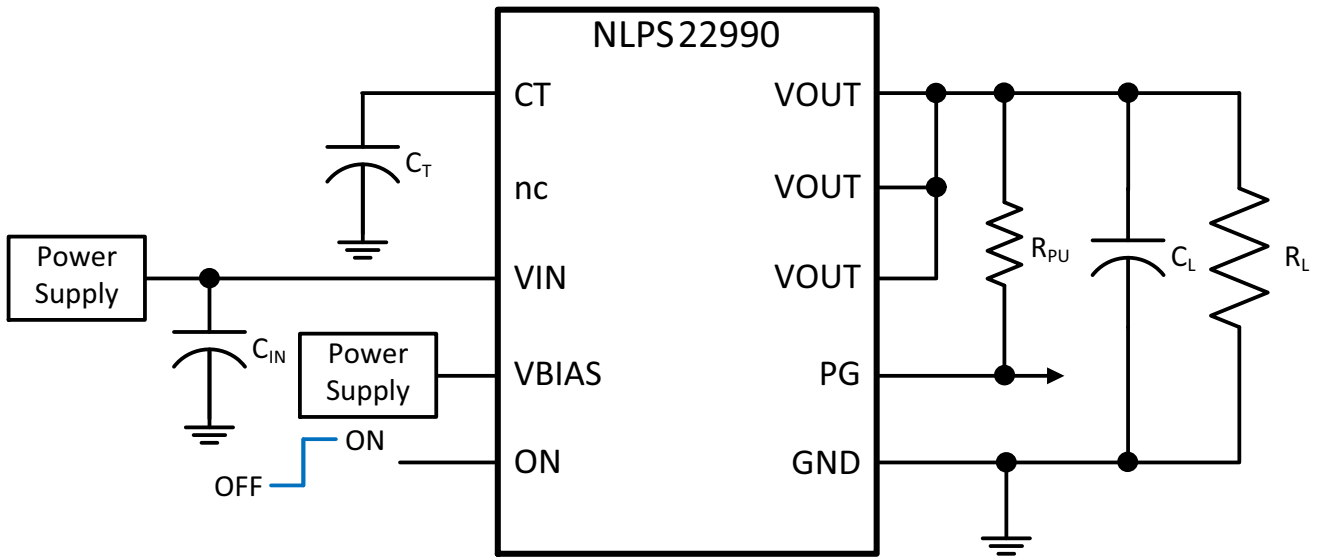
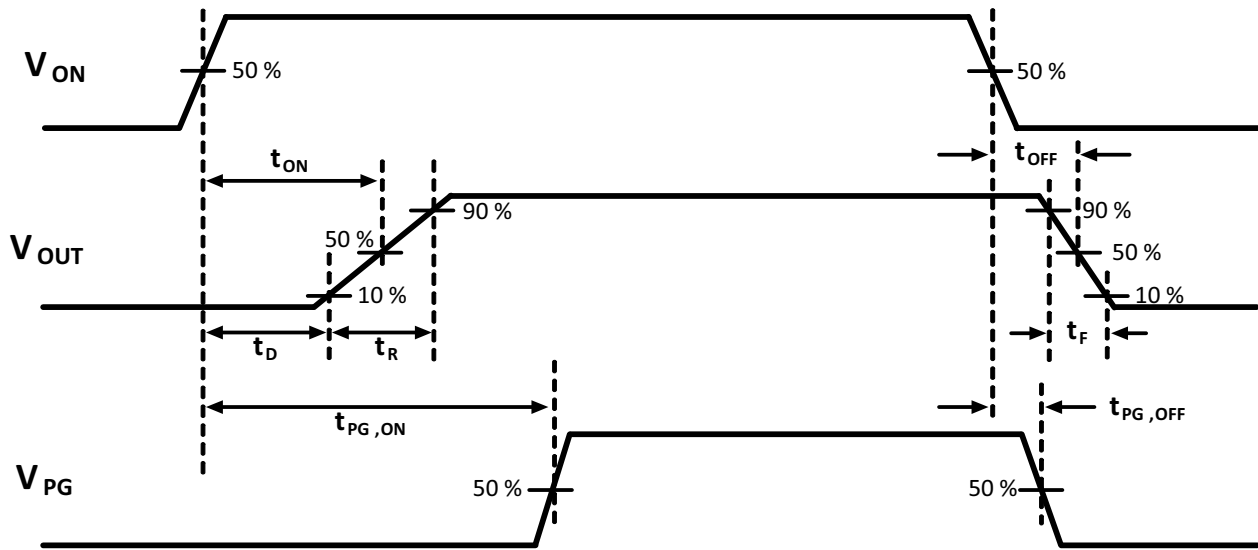

Figure 38. Timing Test Circuit



Rise/fall time of the control signals is 100 ns.

Figure 39. Timing Waveforms

# NLPS22990, NLPS22990N

## Detailed Description

### Overview

The NLPS22990 / NLPS22990N device is a single channel load switch with controlled adjustable turn-on time and an integrated PG indicator. The device contains an N-channel MOSFET that can operate over an input voltage range of 0.6 V to 5.5 V and can support a maximum continuous current of 10 A. The wide input voltage range and high current capability enable this device to be used across multiple designs and end equipment. The on-resistance of 3.9-mΩ minimizes the voltage drop across the load switch and the power loss due to the load switch.

The controlled rise time for the device greatly reduces inrush current caused by large bulk load capacitances, thereby reducing or eliminating power supply droop. Adjustable slew rate through the CT pin provides design flexibility in trading off inrush current and power up timing requirements. The integrated PG indicator notifies the system about the status of the load switch to facilitate seamless power sequencing. During shutdown, the device has very low leakage current, thereby reducing unnecessary leakages for downstream modules during standby. The NLPS22990 features an internal 200-Ω resistor for quick discharge of the output when switch is disabled. The NLPS22990N does not have this quick output discharge feature.

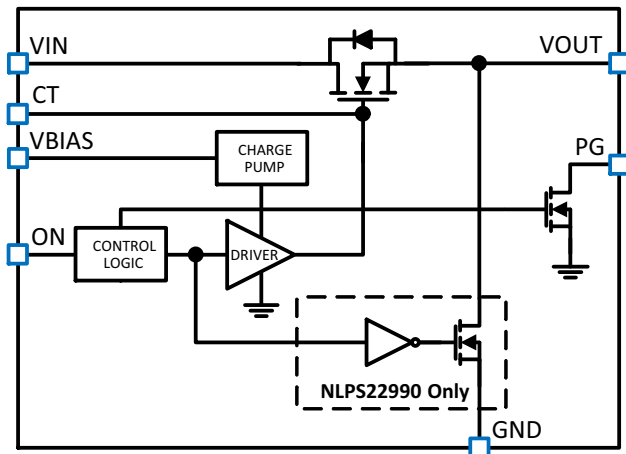

Figure 40. Functional Block Diagram

### Feature Description

#### On and Off Control

The ON pin controls the state of the load switch. Asserting the pin high enables the switch. The minimum voltage that guarantees logic high is 1.0 V. This pin cannot be left floating and must be tied either high or low for proper functionality.

#### Adjustable Rise Time

The NLPS22990 / NLPS22990N features adjustable rise time for inrush current control. A capacitor to GND on the CT pin adjusts the rise time. Without any capacitor on the CT, the rise time is at its minimum for fastest timing. The voltage on the CT pin can be as high as 15 V; therefore the minimum voltage rating for the CT capacitor must be 25 V for optimal performance. An approximate equation for the relationship between CT, V<sub>IN</sub> and rise time when V<sub>BIAS</sub> is set to 5 V is shown in Equation 1. As shown in Figure 39, rise time is defined as from 10% to 90% measurement on V<sub>OUT</sub>.

$$t_R = (0.0058 \times V_{IN} + 0.0005) \times C_T + 5.4 \times V_{IN} + 2.8 \quad (\text{eq. 1})$$

where

- t<sub>R</sub> is the rise time (in μs)
- V<sub>IN</sub> is the input voltage (in V)
- C<sub>T</sub> is the capacitance value on the CT pin (in pF)

Table 9 contains rise time values measured on a typical device. Rise times shown below are only valid for the power-up sequence where V<sub>IN</sub> and V<sub>BIAS</sub> are already in steady state condition before the ON pin is asserted high.

Table 9. RISE TIME VS. CT CAPACITOR

C <sub>T</sub> (pF)	Rise Time (μs) at 25°C, C <sub>L</sub> = 0.1 μF, C <sub>IN</sub> = 1 μF, R <sub>L</sub> = 10 Ω, V <sub>BIAS</sub> = 5 V				
	V <sub>IN</sub> = 5 V	V <sub>IN</sub> = 3.3 V	V <sub>IN</sub> = 1.8 V	V <sub>IN</sub> = 1.05 V	V <sub>IN</sub> = 0.6 V
0	26.4	23.5	19.6	14.2	10.7
220	30.5	26.2	21.4	14.6	11.0
470	36.6	29.4	21.7	16.0	12.2
1000	52.9	40.6	28.1	20.7	14.9
2200	86.6	63.7	41.7	29.0	20.1
4700	160.5	112.0	70.6	46.9	32.7
10000	310.8	214.1	130.4	84.0	56.4

## NLPS22990, NLPS22990N

### Power Good (PG)

The NLPS22990 / NLPS22990N has a power good (PG) output signal used to indicate that the gate of the pass FET is driven high, and that the switch is on with On-resistance close to its final value (full load ready). PG is an active high open-drain output which can be connected to a voltage source through an external pull up resistor,  $R_{PU}$ . This voltage source can be  $V_{OUT}$  from the NLPS22990 / NLPS22990N or another external voltage.  $V_{BIAS}$  is required for PG to have a valid output. Equation 2 shows the approximate equation for the relationship between  $C_T$ ,  $V_{IN}$  and PG turn-on time ( $t_{PG,ON}$ ) when  $V_{BIAS}$  is set to 5 V.

(eq. 2)

$$t_{PG,ON} = (0.0083 \times V_{IN} + 0.023) \times C_T + 4.4 \times V_{IN} + 85$$

where

- $t_{PG,ON}$  is the PG turn-on time (in  $\mu s$ )
- $V_{IN}$  is the input voltage (in V)
- $C_T$  is the capacitance value on the CT pin (in pF)

Table 10 contains PG turn-on time values measured on a typical device.

**Table 10. PG TURN-ON TIME VS. CT CAPACITOR**

$C_T$ (pF)	Typical PG Turn-on Time ( $\mu s$ ) at 25°C $C_L = 0.1 \mu F$ , $C_{IN} = 1 \mu F$ , $R_L = 10 \Omega$ , $V_{BIAS} = 5 V$				
	$V_{IN} = 5 V$	$V_{IN} = 3.3 V$	$V_{IN} = 1.8 V$	$V_{IN} = 1.05 V$	$V_{IN} = 0.6 V$
0	110.86	101.19	95.5	92.01	91.68
220	125.05	112.49	104.0	99.84	97.7
470	140.84	125.02	114.01	108.67	104.53
1000	174.71	151.86	134.84	126.33	120.87
2200	249.15	210.8	179.5	164.72	155.37
4700	408.76	335.95	276.0	246.93	229.46
10000	734.93	594.64	474.98	415.5	380.43

### Quick Output Discharge (QOD) (NLPS22990 Only)

The NLPS22990 includes a QOD feature. When the switch is disabled, a discharge resistor is connected between  $V_{OUT}$  and GND. This resistor has a typical value of 200  $\Omega$  and prevents the output from floating while the switch is disabled.

The NLPS22990N does not have this feature.

### Device Functional Modes

Table 11 shows the function table for NLPS22990.

**Table 11. FUNCTION TABLE**

ON	$V_{IN}$ to $V_{OUT}$	OUTPUT DISCHARGE (Note 6)
L	OFF	ENABLED
H	ON	DISABLED

6. This feature is in the NLPS22990 only (not in NLPS22990N).



## Application and Implementation

### Application Information

#### Input to Output Voltage Drop

The input to output voltage drop in the device is determined by the  $R_{ON}$  of the device and the load current. The  $R_{ON}$  of the device depends upon the  $V_{IN}$  and  $V_{BIAS}$  conditions of the device. See the  $R_{ON}$  specifications in the Resistance Characteristics table of this datasheet. Once the  $R_{ON}$  of the device is determined based upon the  $V_{IN}$  and  $V_{BIAS}$  conditions, use Equation 3 to calculate the input to output voltage drop.

$$\Delta V = I_{LOAD} \times R_{ON} \quad (\text{eq. 3})$$

where

- $\Delta V$  is the voltage drop from  $V_{IN}$  to  $V_{OUT}$
- $I_{LOAD}$  is the load current
- $R_{ON}$  is the on-resistance of the device for a specific  $V_{IN}$  and  $V_{BIAS}$
- An appropriate  $I_{LOAD}$  must be chosen such that the  $I_{MAX}$  specification of the device is not violated

#### Input Capacitor

The use of a capacitor between  $V_{IN}$  and GND close to these pins is recommended. This helps limit the voltage drop on the input supply caused by transient inrush currents into a discharged capacitor at the load when the switch is turned on. A 1- $\mu$ F ceramic capacitor,  $C_{IN}$ , is usually sufficient. Higher values of  $C_{IN}$  can be used to further reduce the voltage drop. A  $C_{IN}$  to  $C_L$  ratio of 10 to 1 is recommended for minimizing  $V_{IN}$  dip caused by inrush currents during startup.  $C_L$  refers to the load capacitance.

#### Thermal Consideration

The maximum junction temperature should be limited below 125°C. Use Equation 4 to calculate the maximum allowable dissipation,  $P_{D(max)}$  for a given output load current and ambient temperature.  $R_{\theta JA}$  is highly dependent upon board layout.

$$P_{D(max)} = \frac{T_{J(max)} - T_A}{R_{\theta JA}} \quad (\text{eq. 4})$$

where

- $P_{D(max)}$  is the maximum allowable power dissipation
- $T_{J(max)}$  is the maximum allowable junction temperature
- $T_A$  is the ambient temperature
- $R_{\theta JA}$  is the junction-to-air thermal impedance

#### PG Pull Up Resistor

PG is an open-drain output which should be connected to a voltage source through a pull up resistor  $R_{PU}$ . The PG signal can be used to drive the enable pins of downstream devices, EN. PG is active high, and its voltage is given by Equation 5.

$$V_{PG} = V_{OUT} - (I_{PG,LK} + I_{EN,LK}) \times R_{PU} \quad (\text{eq. 5})$$

where

- $V_{OUT}$  is the voltage where PG is tied to
- $I_{PG,LK}$  is the leakage current into PG pin
- $I_{EN,LK}$  is the leakage current into the EN pin driven by PG
- $R_{PU}$  is the pull up resistance

$V_{PG}$  needs to be higher than  $V_{IH,MIN}$  of the EN pin to be interpreted as a valid logic high. The maximum  $R_{PU}$  is determined by Equation 6.

$$R_{PU,MAX} = \frac{V_{OUT} - V_{IH,MIN}}{I_{PG,LK} + I_{EN,LK}} \quad (\text{eq. 6})$$

When PG is disabled, a 1 mA current into PG pin ( $I_{PG} = 1$  mA) produces a  $V_{PG,OL}$  of less than 0.2 V. This  $V_{PG,OL}$  will be interpreted as a valid logic low as long as  $V_{IL,MAX}$  of the EN pin is greater than 0.2 V. The minimum  $R_{PU}$  is determined by Equation 7.

$$R_{PU,MIN} = \frac{V_{OUT}}{I_{PG} + I_{EN,LK}} \quad (\text{eq. 7})$$

$R_{PU}$  can be chosen within the range defined by  $R_{PU,MIN}$  and  $R_{PU,MAX}$ .  $R_{PU} = 10$  k $\Omega$  is used for characterization.

## NLPS22990, NLPS22990N

### Power Sequencing

The NLPS22990 / NLPS22990N has an integrated power good indicator which can be used for power sequencing. As shown in Figure 41, the switch to the second load is controlled by the PG signal from the first switch. This

ensures that the power to load 2 is only enabled after the power to load 1 is enabled and the first switch is full-load ready.

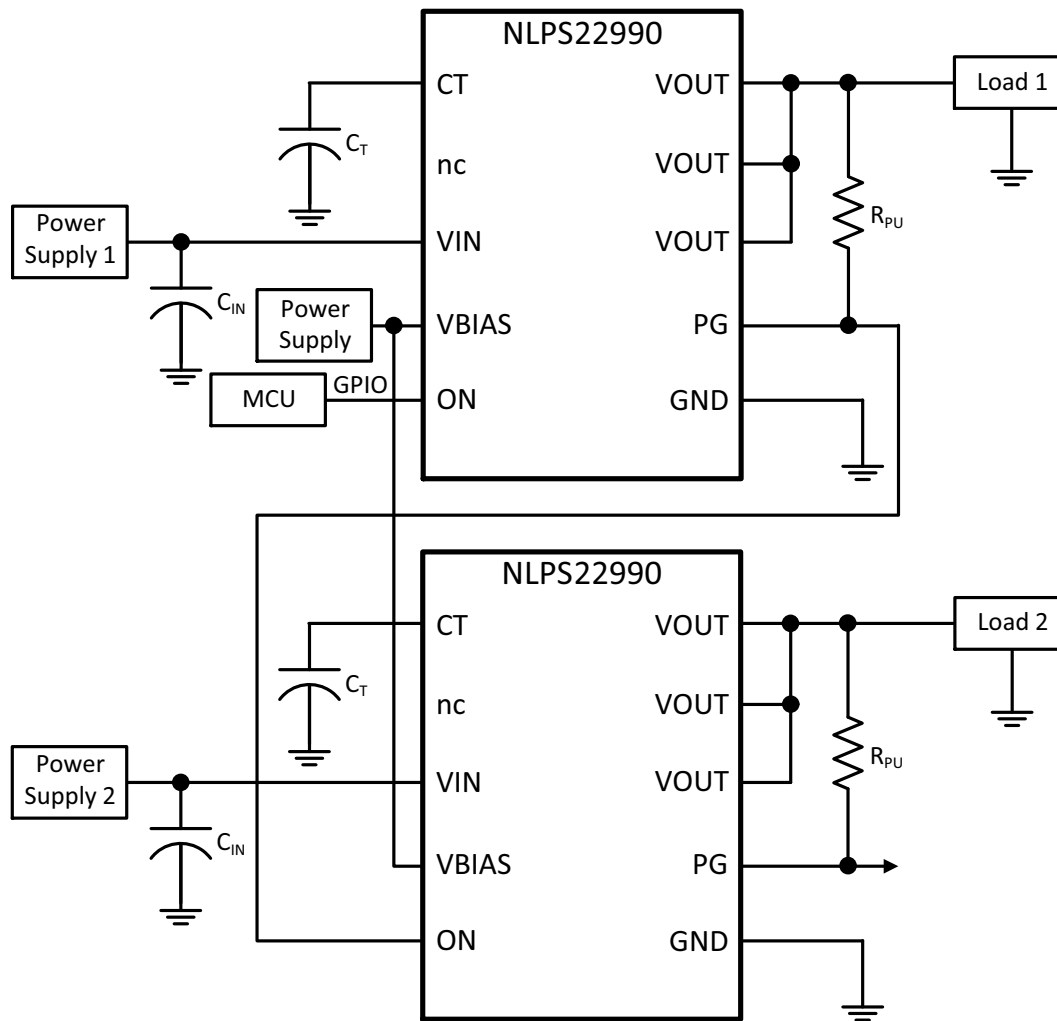

Figure 41. Power Sequencing

## NLPS22990, NLPS22990N

### Standby Power Reduction

Any end equipment that is powered by a battery sees the need to reduce current consumption in order to maintain the battery charge for a longer time. The NLPS22990 / NLPS22990N devices help to accomplish this reduction by

turning off the supply to the downstream modules that are in standby state. Turning off the supply significantly reduces the leakage current overhead of the standby modules as shown in Figure 42.

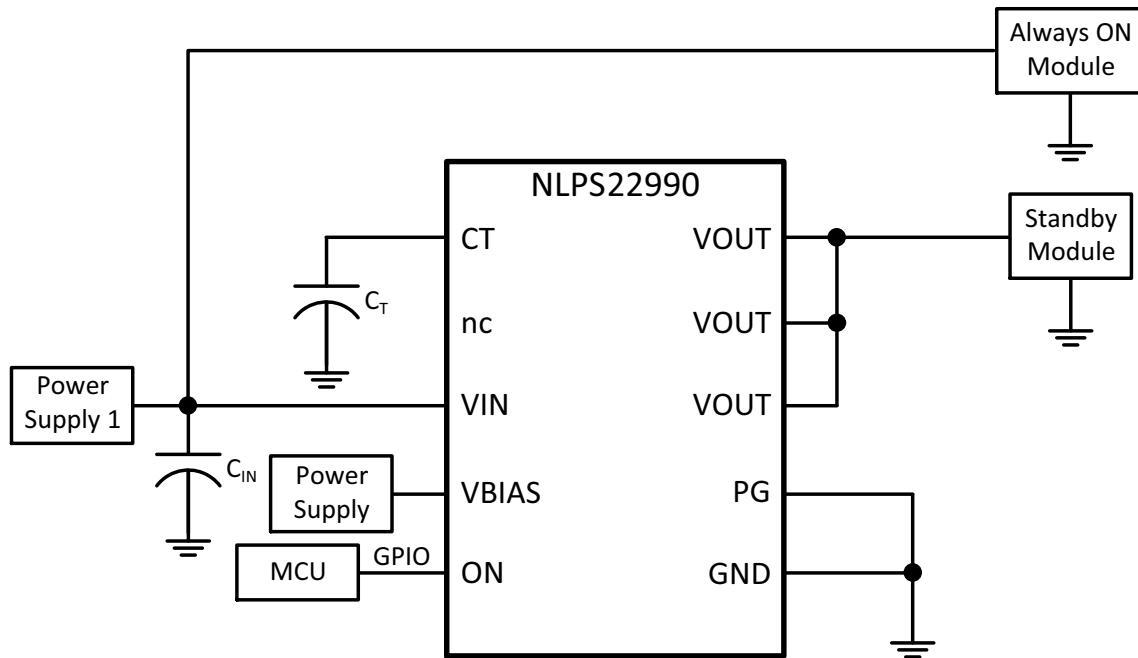

Figure 42. Standby Power Reduction

### Power Supply Recommendations

The device is designed to operate with a  $V_{BIAS}$  range of 2.5 V to 5.5 V, and a  $V_{IN}$  range of 0.6 V to  $V_{BIAS}$ . The supply must be well regulated and placed as close to the device terminal as possible with the recommended 1- $\mu$ F bypass capacitor. If the supply is located more than a few inches



from the device terminals, additional bulk capacitance may be required in addition to the ceramic bypass capacitors. In the case where the power supply is slow to respond to a large load current step, additional bulk may also be required. If additional bulk capacitance is required, an electrolytic, tantalum, or ceramic capacitor of 10  $\mu$ F may be sufficient.

**Layout**

**Layout Guidelines**

For best performance, all traces must be as short as possible. To be most effective, the input and output

capacitors must be placed close to the device to minimize the effects that parasitic trace inductances may have on normal operation. Using wide traces for  $V_{IN}$ ,  $V_{OUT}$ , and GND helps minimize the parasitic electrical effects. The  $C_T$  trace must be as short as possible to reduce parasitic capacitance.

-  VIA to Power Ground Plane
-  VIA to VIN Plane

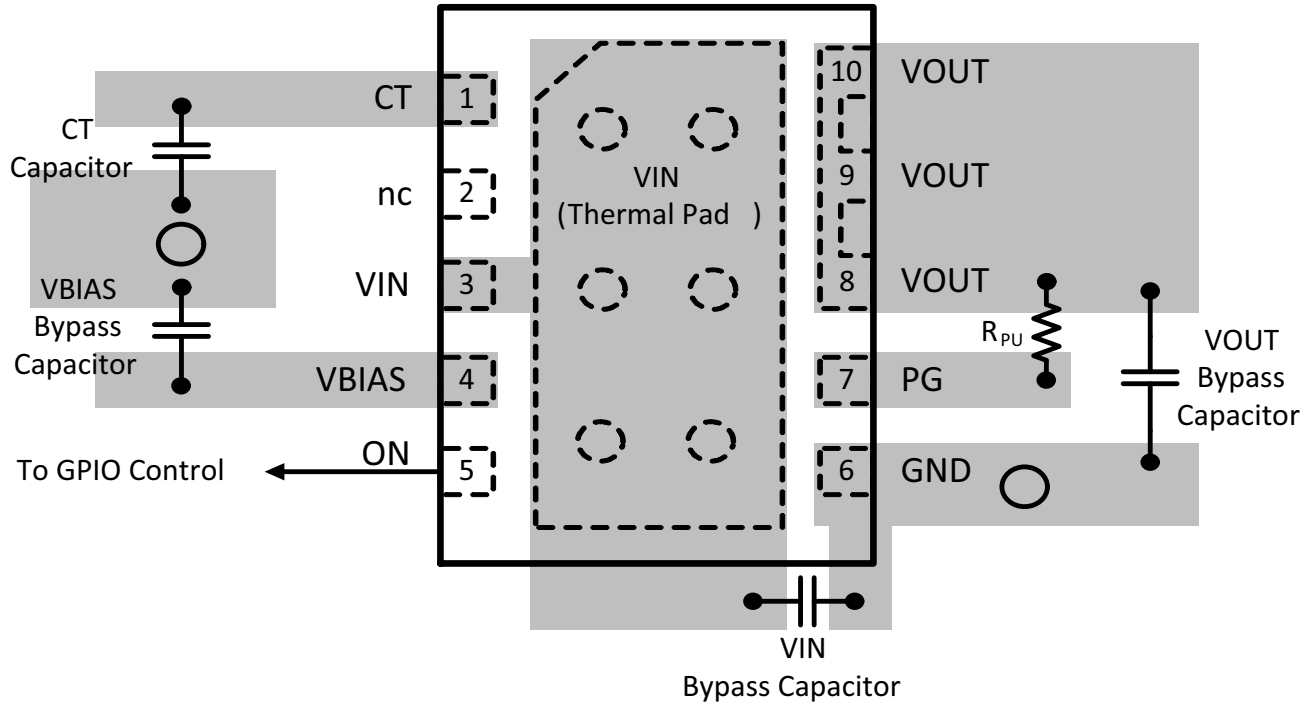
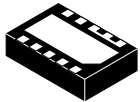

Figure 43. Layout Example

# MECHANICAL CASE OUTLINE

## PACKAGE DIMENSIONS

ON Semiconductor®



SCALE 4:1

### WDFN10 3.0x2.0, 0.5P CASE 511DX ISSUE A

DATE 15 NOV 2018

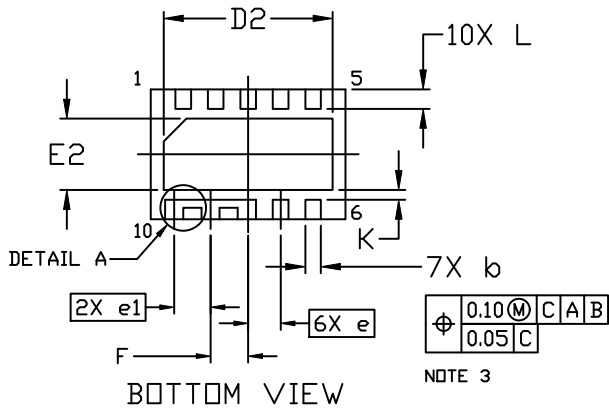
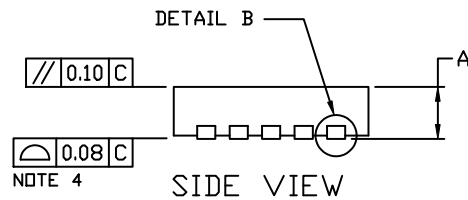
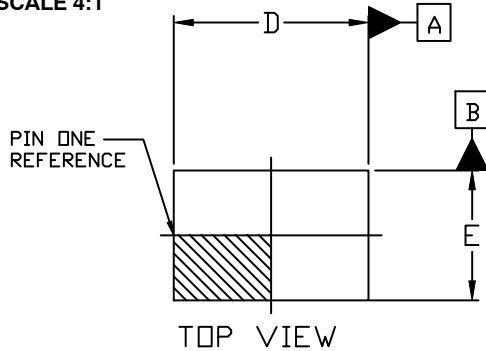

NOTES:

1. DIMENSIONING AND TOLERANCING PER ASME Y14.5M, 1994.
2. CONTROLLING DIMENSION: MILLIMETERS
3. DIMENSION b, b1 AND b2 APPLIES TO THE PLATED TERMINALS AND IS MEASURED BETWEEN 0.10 AND 0.20mm FROM THE TERMINAL TIP.
4. PROFILE APPLIES TO THE EXPOSED PAD AS WELL AS THE TERMINALS.

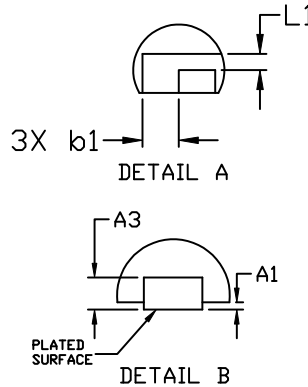

DIM	MILLIMETERS		
	MIN.	NOM.	MAX.
A	0.70	0.75	0.80
A1	0.00	---	0.05
A3	0.20 REF		
b	0.19	0.24	0.29
b1	0.23	0.28	0.33
D	2.90	3.00	3.10
D2	2.50	2.60	2.70
E	1.90	2.00	2.10
E2	1.00	1.10	1.20
e	0.50 BSC		
e1	0.56 BSC		
F	0.58 REF		
k	0.15 REF		
L	0.25	0.30	0.35
L1	0.125 REF		

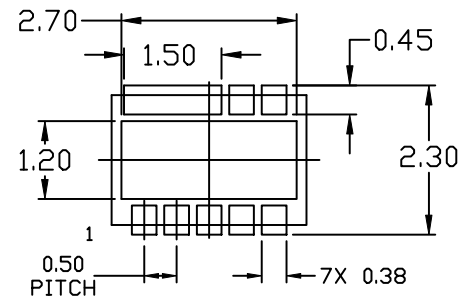

### GENERIC MARKING DIAGRAM\*

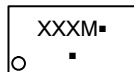

XXX = Specific Device Code  
M = Date Code  
▪ = Pb-Free Package

(Note: Microdot may be in either location)

\*This information is generic. Please refer to device data sheet for actual part marking. Pb-Free indicator, "C" or microdot "▪", may or may not be present. Some products may not follow the Generic Marking.

\* For additional information on our Pb-Free strategy and soldering details, please download the ON Semiconductor Soldering and Mounting Techniques Reference Manual, SOLDERRM/D.

<b>DOCUMENT NUMBER:</b>	<b>98AON80338G</b>	Electronic versions are uncontrolled except when accessed directly from the Document Repository. Printed versions are uncontrolled except when stamped "CONTROLLED COPY" in red.
<b>DESCRIPTION:</b>	<b>WDFN10 3.0x2.0, 0.5P</b>	<b>PAGE 1 OF 1</b>

ON Semiconductor and ON are trademarks of Semiconductor Components Industries, LLC dba ON Semiconductor or its subsidiaries in the United States and/or other countries. ON Semiconductor reserves the right to make changes without further notice to any products herein. ON Semiconductor makes no warranty, representation or guarantee regarding the suitability of its products for any particular purpose, nor does ON Semiconductor assume any liability arising out of the application or use of any product or circuit, and specifically disclaims any and all liability, including without limitation special, consequential or incidental damages. ON Semiconductor does not convey any license under its patent rights nor the rights of others.

**onsemi**, **Onsemi**, and other names, marks, and brands are registered and/or common law trademarks of Semiconductor Components Industries, LLC dba "**onsemi**" or its affiliates and/or subsidiaries in the United States and/or other countries. **onsemi** owns the rights to a number of patents, trademarks, copyrights, trade secrets, and other intellectual property. A listing of **onsemi**'s product/patent coverage may be accessed at [www.onsemi.com/site/pdf/Patent-Marking.pdf](http://www.onsemi.com/site/pdf/Patent-Marking.pdf). **onsemi** reserves the right to make changes at any time to any products or information herein, without notice. The information herein is provided "as-is" and **onsemi** makes no warranty, representation or guarantee regarding the accuracy of the information, product features, availability, functionality, or suitability of its products for any particular purpose, nor does **onsemi** assume any liability arising out of the application or use of any product or circuit, and specifically disclaims any and all liability, including without limitation special, consequential or incidental damages. Buyer is responsible for its products and applications using **onsemi** products, including compliance with all laws, regulations and safety requirements or standards, regardless of any support or applications information provided by **onsemi**. "Typical" parameters which may be provided in **onsemi** data sheets and/or specifications can and do vary in different applications and actual performance may vary over time. All operating parameters, including "Typicals" must be validated for each customer application by customer's technical experts. **onsemi** does not convey any license under any of its intellectual property rights nor the rights of others. **onsemi** products are not designed, intended, or authorized for use as a critical component in life support systems or any FDA Class 3 medical devices or medical devices with a same or similar classification in a foreign jurisdiction or any devices intended for implantation in the human body. Should Buyer purchase or use **onsemi** products for any such unintended or unauthorized application, Buyer shall indemnify and hold **onsemi** and its officers, employees, subsidiaries, affiliates, and distributors harmless against all claims, costs, damages, and expenses, and reasonable attorney fees arising out of, directly or indirectly, any claim of personal injury or death associated with such unintended or unauthorized use, even if such claim alleges that **onsemi** was negligent regarding the design or manufacture of the part. **onsemi** is an Equal Opportunity/Affirmative Action Employer. This literature is subject to all applicable copyright laws and is not for resale in any manner.

## PUBLICATION ORDERING INFORMATION

### LITERATURE FULFILLMENT:

Email Requests to: [orderlit@onsemi.com](mailto:orderlit@onsemi.com)

**onsemi Website:** [www.onsemi.com](http://www.onsemi.com)

### TECHNICAL SUPPORT

**North American Technical Support:**

Voice Mail: 1 800-282-9855 Toll Free USA/Canada

Phone: 011 421 33 790 2910

**Europe, Middle East and Africa Technical Support:**

Phone: 00421 33 790 2910

For additional information, please contact your local Sales Representative



单击下面可查看定价，库存，交付和生命周期等信息

[>>ON Semiconductor\(安森美\)](#)