



# ORIENT

## Photo coupler

### Product Data Sheet

Part Number: OR-3120\_OR-3150

Customer: \_\_\_\_\_

Date: \_\_\_\_\_

**SHENZHEN ORIENT COMPONENTS CO ., LTD**

Block A 3rd Floor No.4 Building, Tian'an Cyber Park, Huangge Rd, LongGang Dist, Shenzhen, GD

TEL: 0755-29681816  
FAX: 0755-29681200  
[www.orient-opto.com](http://www.orient-opto.com)

## 1. Features

- (1) 0.6A maximum peak output current for OR-3150,  
2.5A maximum peak output current for OR-3120.
- (2) 0.5A minimum peak output current for OR-3150,  
2.0A minimum peak output current for OR-3120.
- (3) 15-kV/ $\mu$ s minimum Common Mode Rejection (CMR) at  $V_{CM} = 1500V$
- (4) 1.0V maximum low level output voltage ( $V_{OL}$ ) eliminates need for negative gate drive
- (5)  $I_{CC} = 5$  mA maximum supply current
- (6) Under voltage lock-out protection (UVLO) with hysteresis
- (7) Wide operating  $V_{CC}$  range: 15V to 30V
- (8) 0.5 $\mu$ s maximum propagation delay
- (9)  $\pm 0.35\mu$ s maximum delay between devices/channels
- (10) Industrial temperature range:  $-40^{\circ}C$  to  $100^{\circ}C$
- (11) Safety approval
  - UL approved(No.E323844)
  - VDE approved(No.40029733)
  - CQC approved (No.CQC19001231254 )
- (12) In compliance with RoHS, REACH standards
- (13) MSL Class I

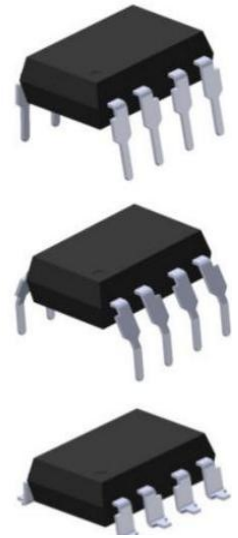

## 2. Instructions

The OR-3120/OR-3150 consists of an LED optically coupled to an integrated circuit with a power output stage. This optocoupler is ideally suited for driving power IGBTs and MOSFETs used in motor control inverter applications. The high operating voltage range of the output stage provides the drive voltages required by gate-controlled devices. The voltage and current supplied by this optocoupler makes it ideally suited for directly driving IGBTs with ratings up to 1200V/50A.

## 3. Application Range

- (1) IGBT/MOSFET gate drive
- (2) AC/Brushless DC motor drives
- (3) Industrial inverters
- (4) Switch mode power supplies

#### 4. Functional Diagram

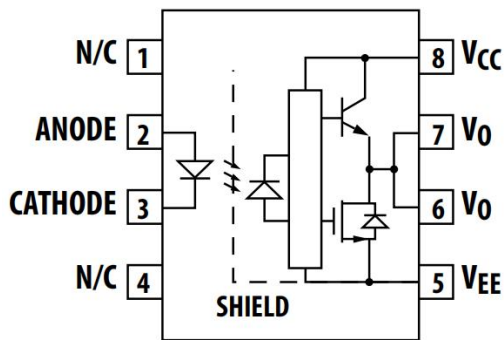

LED	$V_{CC} - V_{EE}$ “POSITIVE GOING” (i.e., TURN-ON)	$V_{CC} - V_{EE}$ “NEGATIVE GOING” (i.e., TURN-OFF)	$V_O$
OFF	0–30 V	0–30 V	LOW
ON	0–11 V	0–9.5 V	LOW
ON	11–13.5 V	9.5–12 V	TRANSITION
ON	13.5–30 V	12–30 V	HIGH

A0.1 $\mu$ F bypass capacitor must be connected between pins 5 and 8.

#### 5. Absolute Maximum Ratings ( $T_a=25^\circ\text{C}$ )\*1

Parameter		Symbol	Rated Value	Unit
Input	Average Forward Input Current	$I_F$	25	mA
	Reverse Input Voltage	$V_R$	5	V
Output	“High” Peak Output Current	OR-3120	2.5	A
		OR-3150	0.6	
	“Low” Peak Output Current	OR-3120	2.5	A
		OR-3150	0.6	
Output Collector Power Dissipation		$P_O$	250	mW
Total Power Dissipation		$P_T$	295	mW
Supply Voltage		$V_{CC}$	35	V
Insulation Voltage		$V_{iso}$	3750	$V_{rms}$
Working Temperature		$T_{opr}$	-40 ~ +110	°C
Storage Temperature		$T_{stg}$	-55 ~ +125	
*2 Soldering Temperature		$T_{sol}$	260	

\*1. Room temperature = 25 °C. Exceeding the maximum absolute rating can permanently damage the device. Working long hours at the maximum absolute rating can affect reliability.

\*2. soldering time is 10 seconds.

## 6. Opto-electronic Characteristics

Parameter		Symbol	Min.	Typ.	Max.	Units	Test Conditions
High Level Output Current	OR-3120	$I_{OH}$	0.5	1.5	—	A	$V_O = (V_{CC} - 4V)$
			2.0	—	—		$V_O = (V_{CC} - 15V)$
	OR-3150		0.1	0.4	—		$V_O = (V_{CC} - 4V)$
			0.5	—	—		$V_O = (V_{CC} - 15V)$
Low Level Output Current	OR-3120	$I_{OL}$	0.5	2.0	—	A	$V_O = (V_{EE} + 2.5V)$
			2.0	—	—		$V_O = (V_{EE} + 15V)$
	OR-3150		0.1	0.6	—		$V_O = (V_{EE} + 2.5V)$
			0.5	—	—		$V_O = (V_{EE} + 15V)$
High Level Output Voltage		$V_{OH}$	$(V_{CC} - 0.3)$	$(V_{CC} - 0.1)$	—	V	$I_O = -100\text{ mA}$
Low Level Output Voltage	OR-3120	$V_{OL}$	—	0.1	0.25	V	$I_O = 100\text{ mA}$
	OR-3150		—	0.4	1.0		
High Level Supply Current		$I_{CCH}$	—	1.6	3.0	mA	Output Open, $I_F = 7\text{ to }16\text{ mA}$
Low Level Supply Current		$I_{CCL}$	—	2.0	3.0	mA	Output Open, $V_F = -3.0\text{ to }+0.8V$
Threshold Input Current Low to High		$I_{FLH}$	—	2.2	5.0	mA	$I_O = 0\text{ mA}$ , $V_O > 5V$
Threshold Input Voltage High to Low		$V_{FHL}$	0.8	—	—	V	$I_O = 0\text{ mA}$ , $V_O < 5V$
Input Forward Voltage		$V_F$	1.2	1.5	1.8	V	$I_F = 10\text{ mA}$
Temperature Coefficient of Forward Voltage		$\Delta V_F / \Delta T_A$	—	-1.6	—	mV/°C	$I_F = 10\text{ mA}$
Input Reverse Breakdown Voltage		$B_{VR}$	5	—	—	V	$I_R = 10\text{ }\mu\text{A}$
Input Capacitance		$C_{IN}$	—	70	—	pF	$f = 1\text{ MHz}$ , $V_F = 0V$
UVLO Threshold		$V_{UVLO+}$	11.0	12.3	13.5	V	$V_O > 5V$ $I_F = 10\text{ mA}$
		$V_{UVLO-}$	9.5	10.7	12.0		
UVLO Hysteresis		$U_{VLOHYS}$	—	1.6	—		

1. All typical values at  $T_A = 25^\circ\text{C}$  and  $V_{CC} - V_{EE} = 30V$ , unless otherwise noted.
2. Maximum pulse width = 10  $\mu\text{s}$ , maximum duty cycle = 0.2%. This value is intended to allow for component tolerances for designs with  $I_O$  peak minimum = 0.5 A. See Applications section for additional details on limiting  $I_{OH}$  peak.
3. Maximum pulse width = 50  $\mu\text{s}$ , maximum duty cycle = 0.5%.
4. In this test,  $V_{OH}$  is measured with a dc load current. When driving capacitive loads  $V_{OH}$  will approach  $V_{CC}$  as  $I_{OH}$  approaches zero amps.
5. Maximum pulse width = 1 ms, maximum duty cycle = 20%.

## 7. Switching Characteristics

Parameter	Symbol	Min.	Typ	Max.	Units	Test Conditions
Propagation Delay Time to High Output Level	$t_{PLH}$	0.10	0.30	0.50	$\mu\text{s}$	<b>OR-3120:</b> $R_g=10\Omega, C_g=10\text{nF}$ , $f=10\text{kHz}$ , Duty Cycle=50%
Propagation Delay Time to Low Output Level	$t_{PHL}$	0.10	0.30	0.50	$\mu\text{s}$	
Pulse Width Distortion	PWD	—	—	0.3	$\mu\text{s}$	<b>OR-3150:</b> $R_g=47\Omega, C_g=3\text{nF}$ , $f=10\text{kHz}$ , Duty Cycle = 50%
Propagation Delay Difference Between Any Two Parts	PDD ( $t_{PHL} - t_{PLH}$ )	-0.35	—	0.35	$\mu\text{s}$	
Rise Time	$t_r$	—	0.1	—	$\mu\text{s}$	
Fall Time	$t_f$	—	0.1	—	$\mu\text{s}$	
UVLO Turn On Delay	$t_{UVLO\ ON}$	—	0.9	—	$\mu\text{s}$	$V_O > 5\text{V}, I_F = 10\text{mA}$
UVLO Turn Off Delay	$t_{UVLO\ OFF}$	—	0.8	—		$V_O < 5\text{V}, I_F = 10\text{mA}$
Output High Level Common Mode Transient Immunity	$ CM_H $	25	35	—	$\text{kV}/\mu\text{s}$	$T_A=25^\circ\text{C}$ , $I_F=10$ to $16\text{mA}$ , $V_{CM}=1500\text{V}$ , $V_{CC}=30\text{V}$
Output Low Level Common Mode Transient Immunity	$ CM_L $	25	35	—	$\text{kV}/\mu\text{s}$	$T_A=25^\circ\text{C}$ , $V_{CM}=1500\text{V}$ , $V_F=0\text{V}, V_{CC}=30\text{V}$

- All typical values at  $T_A = 25^\circ\text{C}$  and  $V_{CC} - V_{EE} = 30\text{V}$ , unless otherwise noted.
- This load condition approximates the gate load of a 1200 V/75A IGBT.
- Pulse Width Distortion (PWD) is defined as  $|t_{PHL} - t_{PLH}|$  for any given device.
- The difference between  $t_{PHL}$  and  $t_{PLH}$  between any two OR-3120 parts under the same test condition.
- Pins 1 and 4 need to be connected to LED common.
- Common mode transient immunity in the high state is the maximum tolerable  $dV_{CM}/dt$  of the common mode pulse,  $V_{CM}$ , to assure that the output will remain in the high state (i.e.,  $V_O > 15.0\text{V}$ ).
- Common mode transient immunity in a low state is the maximum tolerable  $dV_{CM}/dt$  of the common mode pulse,  $V_{CM}$ , to assure that the output will remain in a low state (i.e.,  $V_O < 1.0\text{V}$ ).

## 8. Order Information

Part Number

**OR-3120Y-Z**  
Or **OR-3150Y-Z**

Note

3120 / 3150 = Part Number.

Y = Lead form option (S, M or none)

Z = Tape and reel option ( TA,TA1 or none).

Option	Description	Packing quantity
None	Standard SMD Option	45 units per tube
M	Wide lead bend (0.4 inch spacing)	45 units per tube
TA	Surface mount lead form (low profile) + TA tape & reel option	1000 units per reel
TA1	Surface mount lead form (low profile) + TA1 tape & reel option	1000 units per reel

## 9. Naming Rule

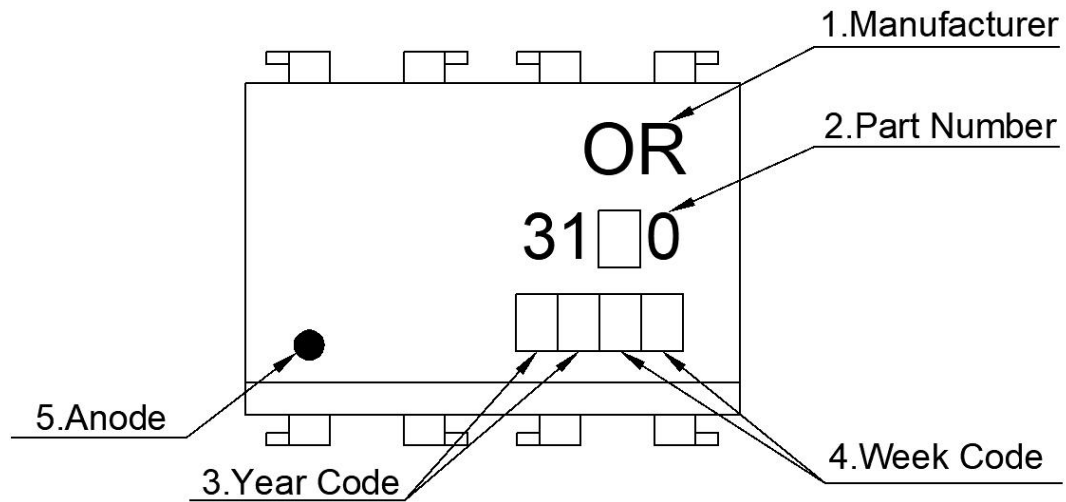

### NOTE:

1. Manufacturer : ORIENT.
2. Part Number : 3120 or 3150.
3. Year Code : '21' means '2021' and so on.
4. Week Code : 01 represents the first week, 02 represents the second week, and so on.
5. Anode.

## 10. Outer Dimension

### (1) OR-3120\_OR-3150

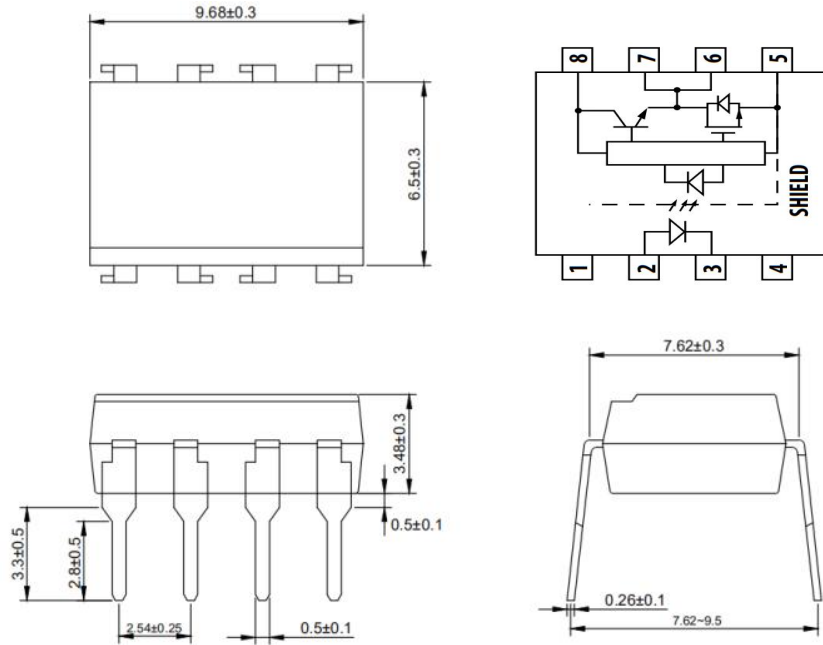

### (2) OR-3120M\_OR-3150M

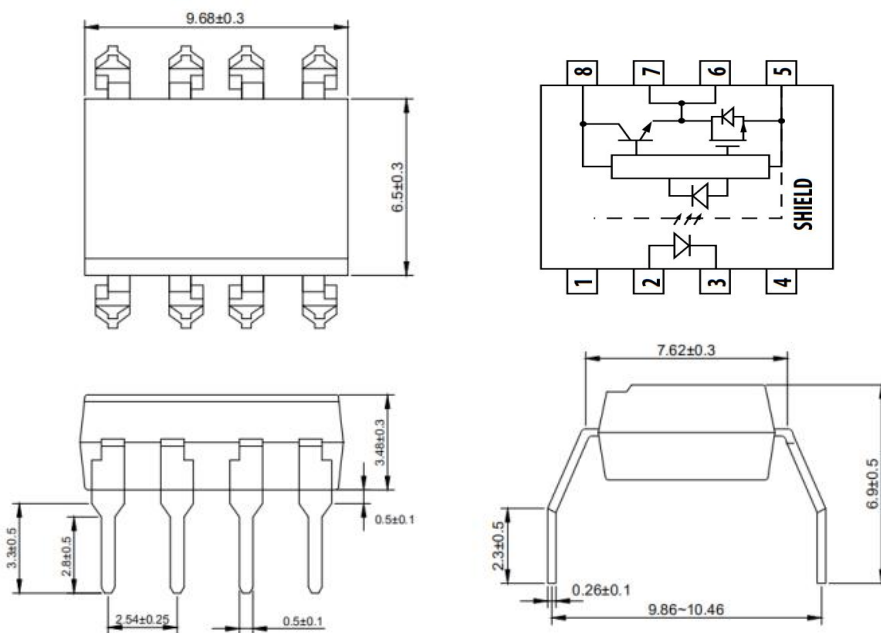



(3) OR-3120S\_OR-3150S

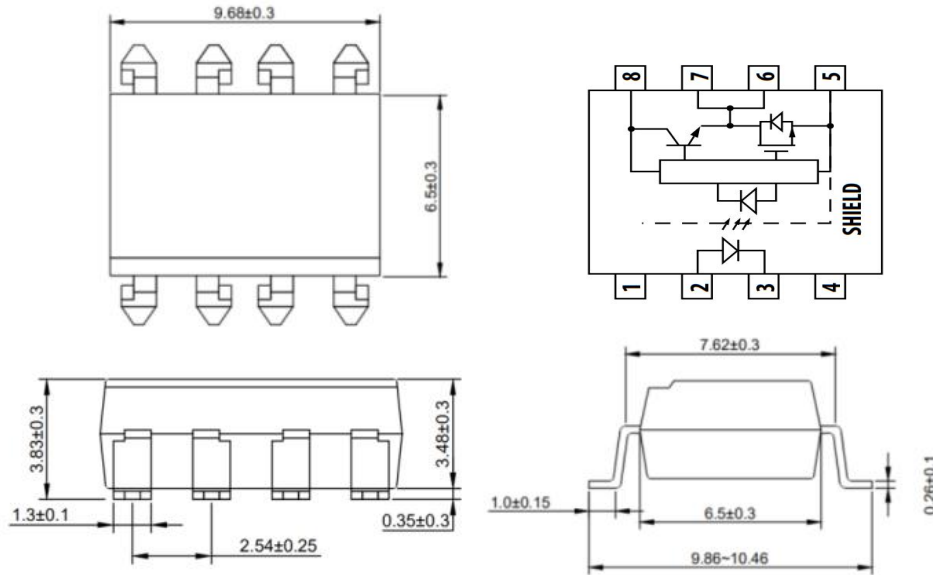

11. Recommended Foot Print Patterns (Mount Pad)

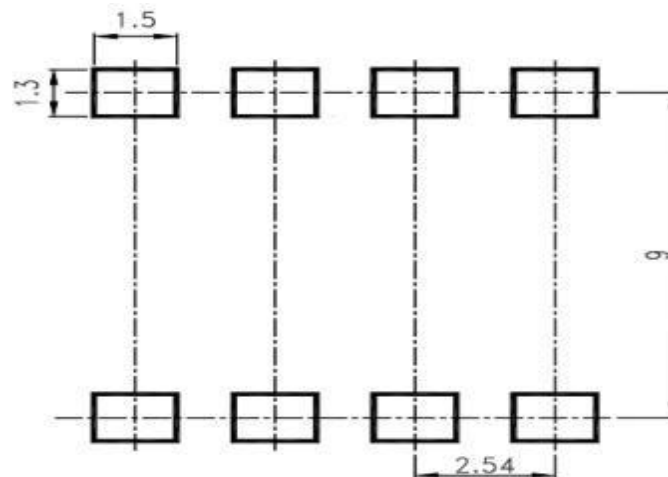

unit: mm

## 12. Taping Dimensions

### (1) OR-3120S-TA\_OR-3150S-TA

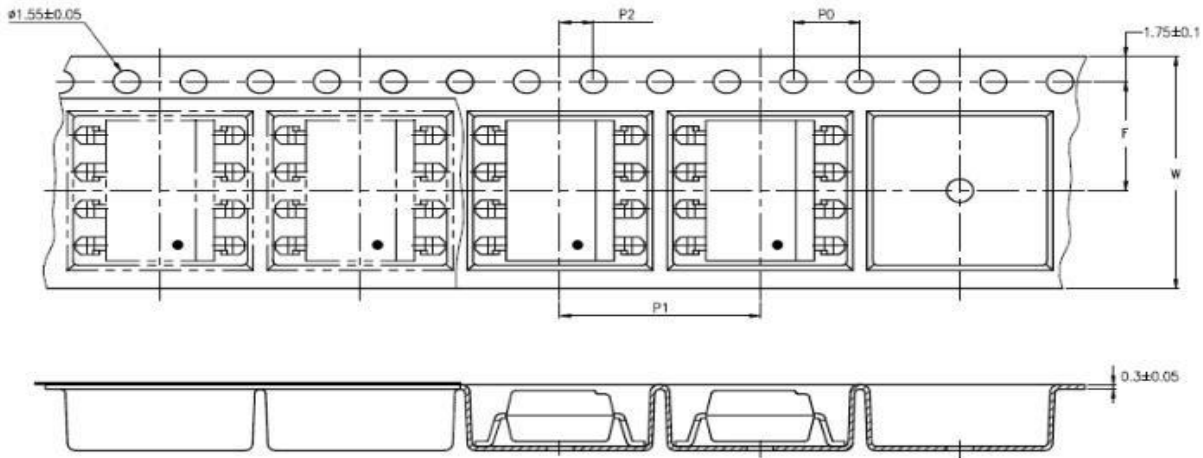

### (2) OR-3120S-TA1\_OR-3150S-TA1

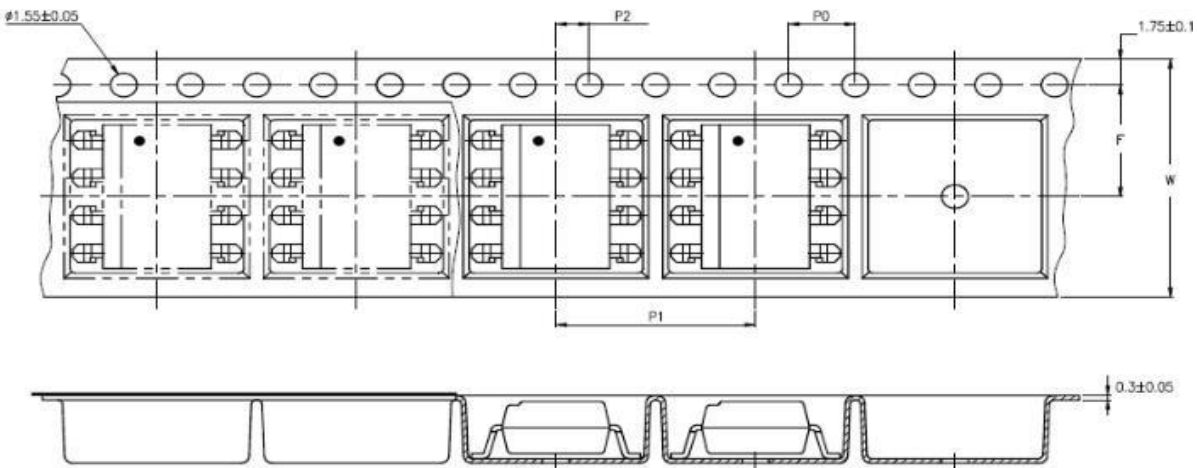

type	symbol	Size: mm ( inches )
bandwidth	W	16±0.3 (0.63)
pitch	P0	4±0.1 (0.15)
pitch	F	7.5±0.1 (0.295)
	P2	2±0.1 (0.079)
interval	P1	12±0.1 (0.472)

Encapsulation type	TA/TA1
amount (pcs)	1000

### 13. Package Dimension

#### (1) package dimension

DIP Type

Packing Information	
Packing type	Tube
Qty per Tube	45pcs
Small box (Inner) Dimension	525*128*60mm
Large box (Outer) Dimension	545*290*335mm
The Amount per Inner Box	2,250pcs
The Amount per Outer Box	22,500pcs

SOP Type

Packing Information	
Packing type	Reel type
Tape Width	16mm
Qty per Reel	1,000pcs
Small box (inner) Dimension	345*345*58.5mm
Large box (Outer) Dimension	620x360x360mm
Max qty per small box	2,000pcs
Max qty per large box	20,000pcs

#### (2)Packing Label Sample



**Note:**

1. P/N :Contents with "Order Information" in the specification.
2. LOT NO : The production lot.
3. BATCH : The Electrical rank.
4. Quantity :Packaging quantity.
5. Product Data :Date of manufacture.

## 14. Temperature Profile Of Soldering

### (1) IR Reflow soldering (JEDEC-STD-020C compliant)

Note: one solder backflow is recommended under the conditions described below in the temperature and time profile. Do not weld more than three times.

Profile item	Conditions
Preheat	150°C
- Temperature Min (T Smin )	200°C
- Temperature Max (T Smax )	90±30 sec
- Time (min to max) (ts)	
Soldering zone	217°C
- Temperature (TL )	60 sec
- Time (t L )	
Peak Temperature	260°C
Peak Temperature time	20 sec
Ramp-up rate	3°C / sec max.
Ramp-down rate from peak temperature	3~6°C / sec
Reflow times	≤3

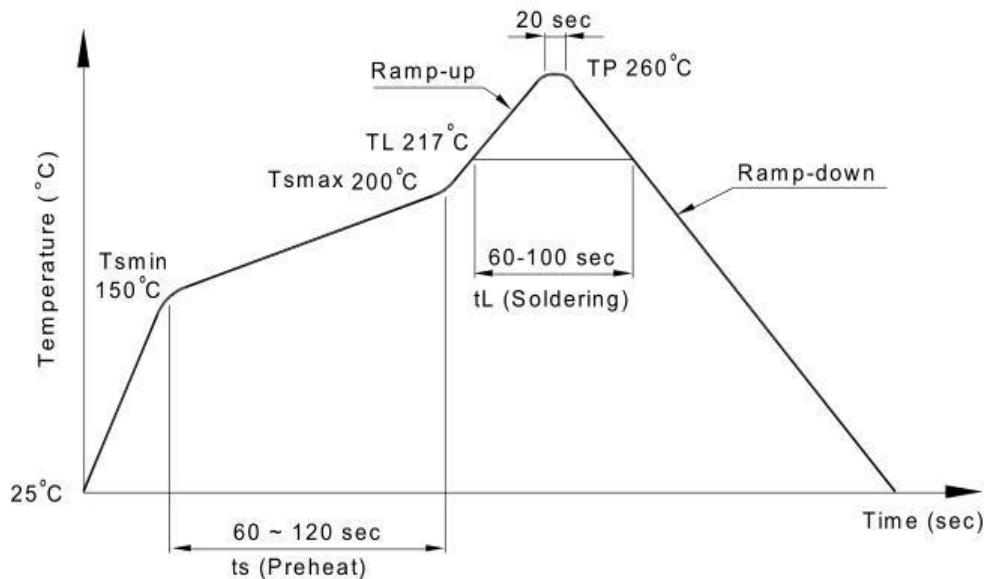

(2) Wave soldering (JEDEC22A111 compliant)

One-time welding is recommended under the temperature condition.

Temperature	260+0/-5°C
Time	10 sec
Preheat temperature	5 to 140°C
Preheat time	30 to 80sec

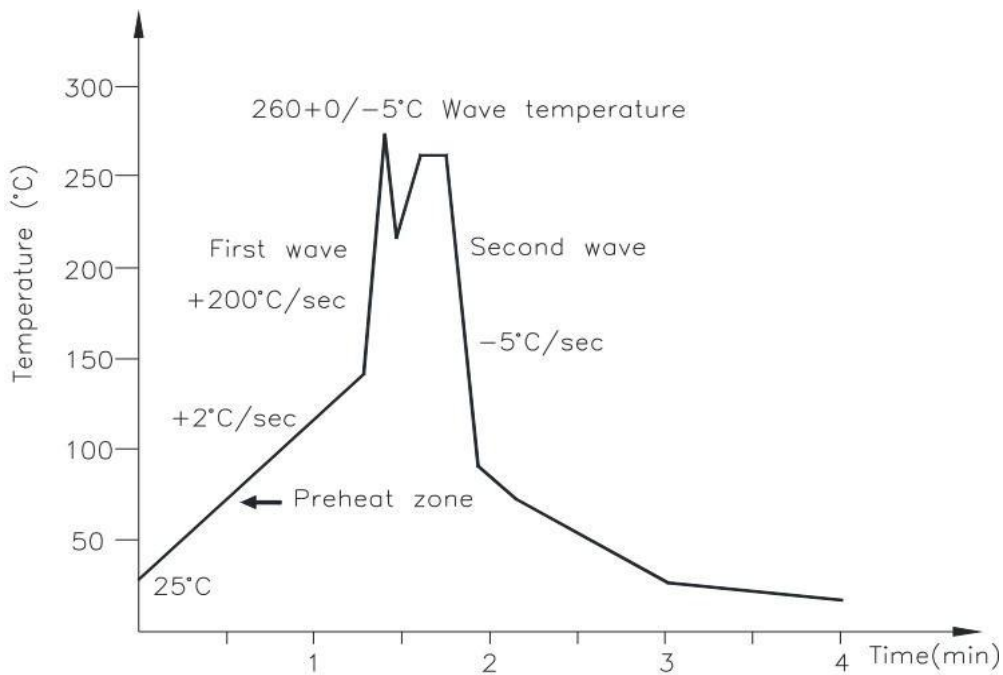

(3) Hand soldering by soldering iron

Single lead welding is allowed in each process and one-time welding is recommended.

Temperature	380+0/-5°C
Time	3 sec max

## 15. Characteristics Curve

Figure 1:  $V_{OH}$  vs. Temperature

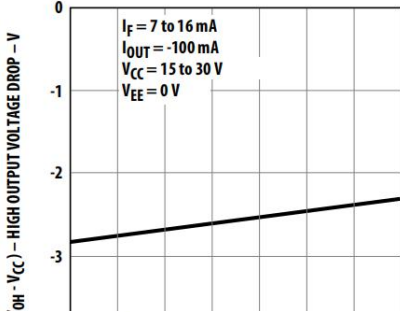

Figure 2:  $I_{OH}$  vs. Temperature

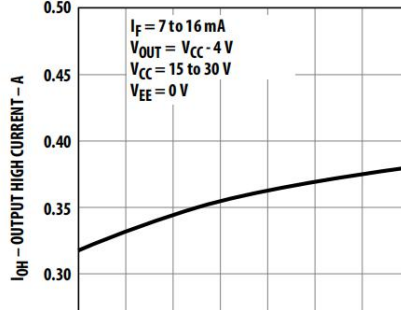

Figure 3:  $V_{OH}$  vs.  $I_{OH}$

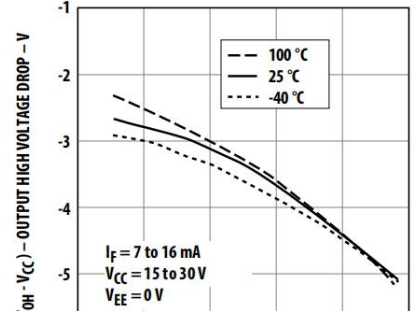

Figure 4:  $V_{OL}$  vs. Temperature

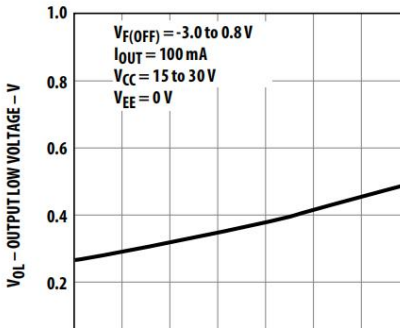

Figure 5:  $I_{OL}$  vs. Temperature

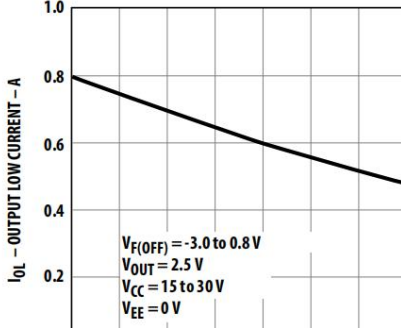

Figure 6:  $V_{OL}$  vs.  $I_{OL}$

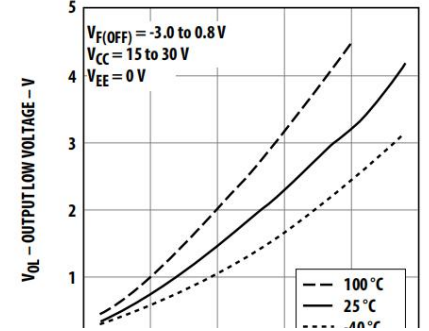

Figure 7:  $I_{CC}$  vs. Temperature

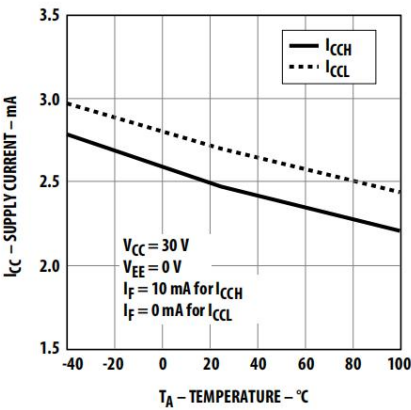

Figure 8:  $I_{CC}$  vs.  $V_{CC}$

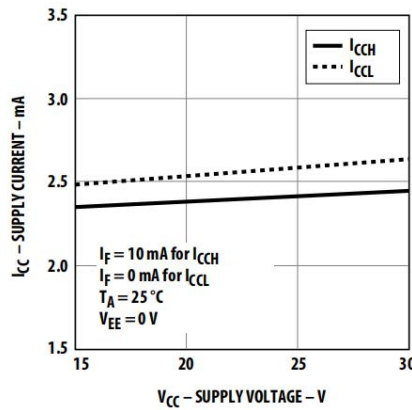
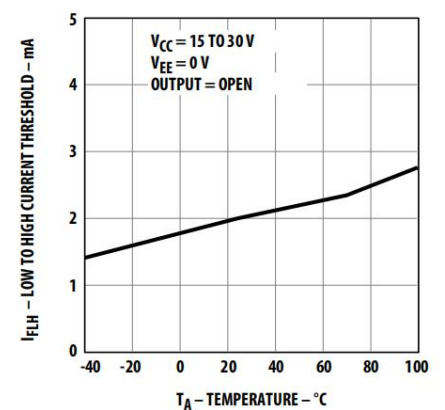
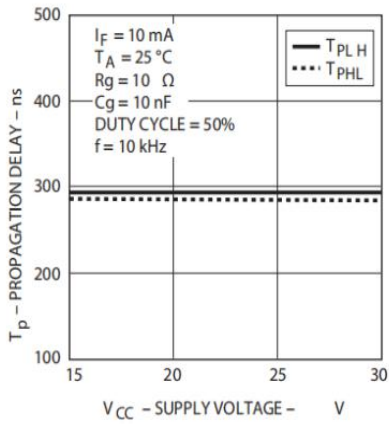

Figure 9:  $I_{FLH}$  vs. Temperature



**Figure 10 Propagation Delay vs.  $V_{CC}$  (OR-3120)**



**Figure 11 Propagation Delay vs.  $I_F$  (OR-3120)**

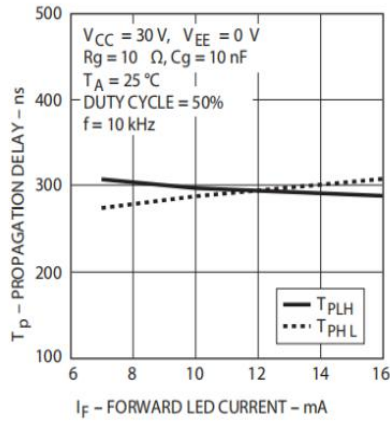

**Figure 12 Propagation Delay vs. Temperature (OR-3120)**

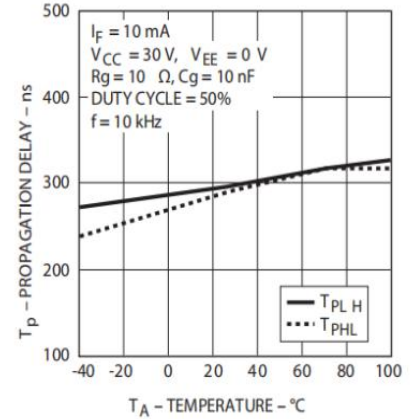

**Propagation Delay vs.  $V_{CC}$  (OR-3150)**

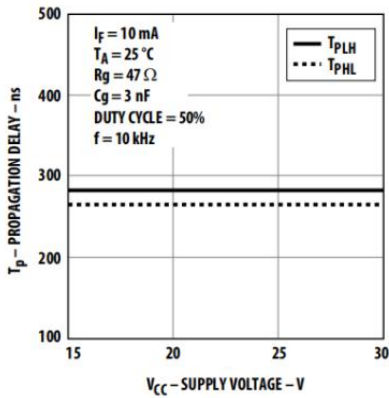

**Propagation Delay vs.  $I_F$  (OR-3150)**

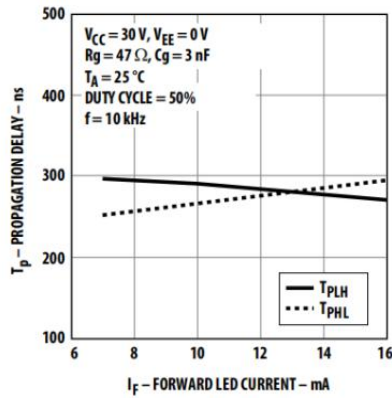

**Propagation Delay vs. Temperature (OR-3150)**

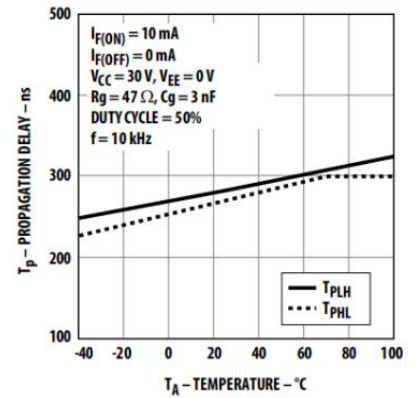

**Figure 13 Propagation Delay vs. Rg (OR-3120)**

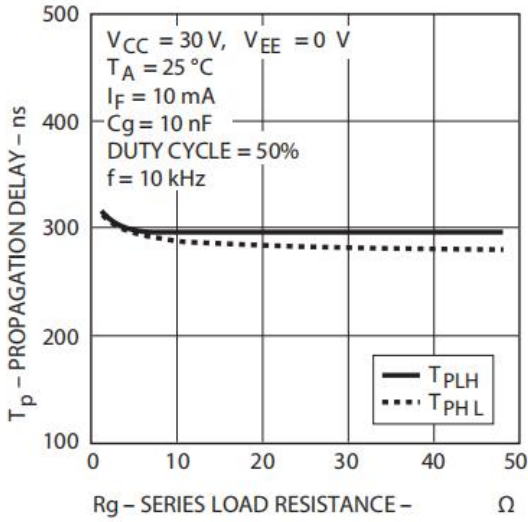

**Figure 14 Propagation Delay vs. Cg (OR-3120)**

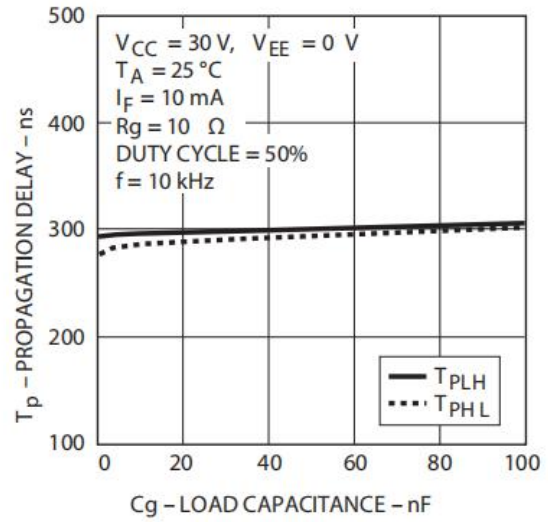

**Propagation Delay vs. Rg (OR-3150)**

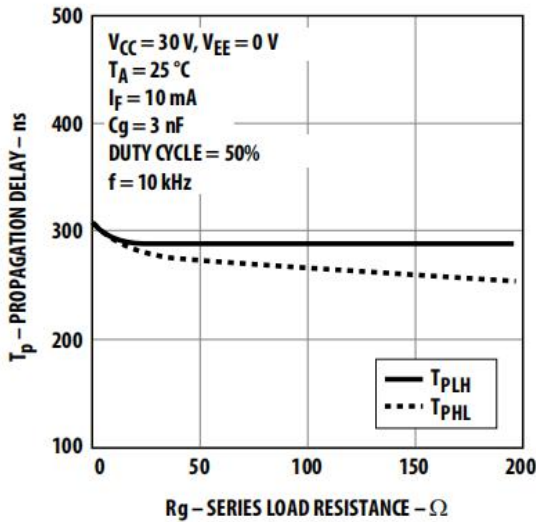

**Propagation Delay vs. Cg (OR-3150)**

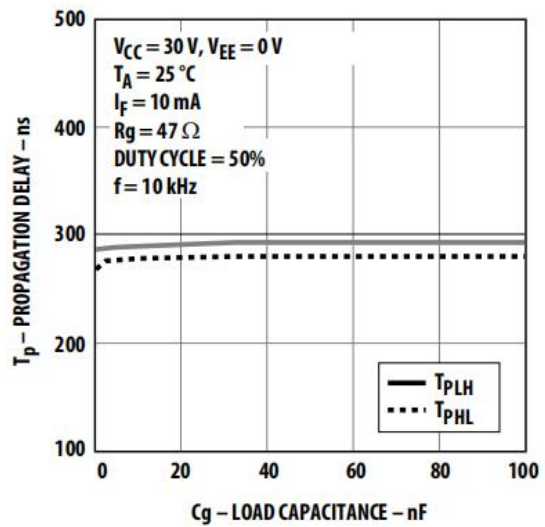



**Figure 15 Transfer Characteristics**

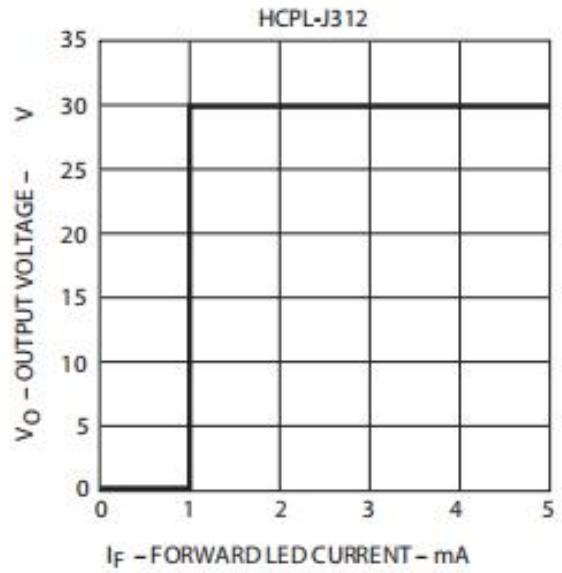
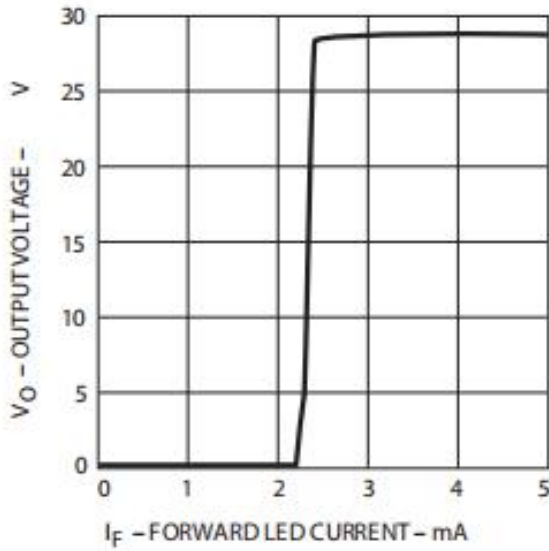

**Figure 16 Input Current vs Forward Voltage**

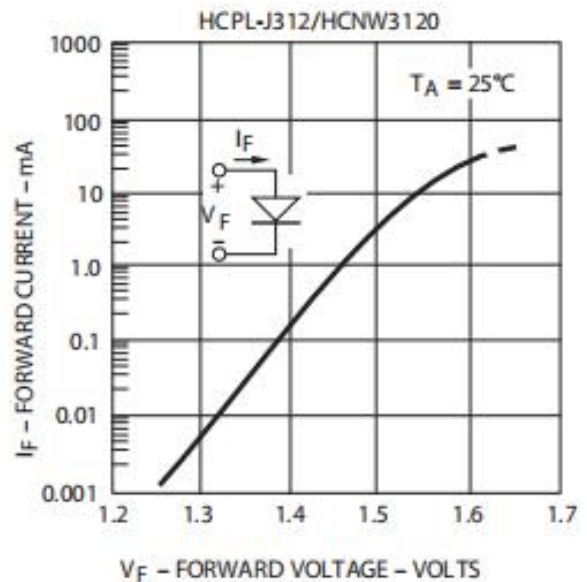
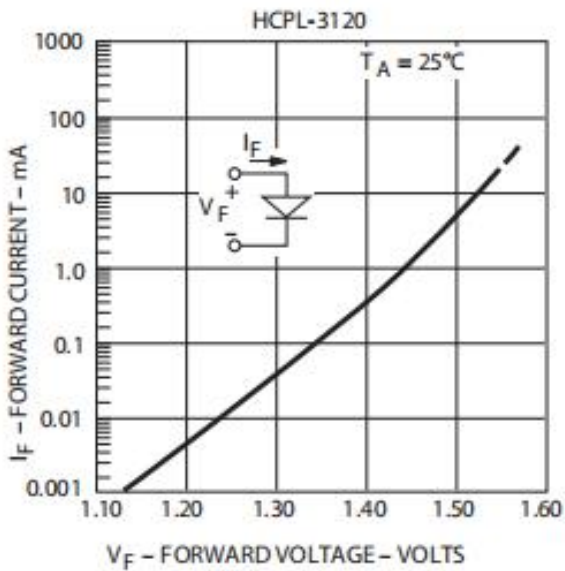

Figure 17:  $I_{OH}$  Test Circuit

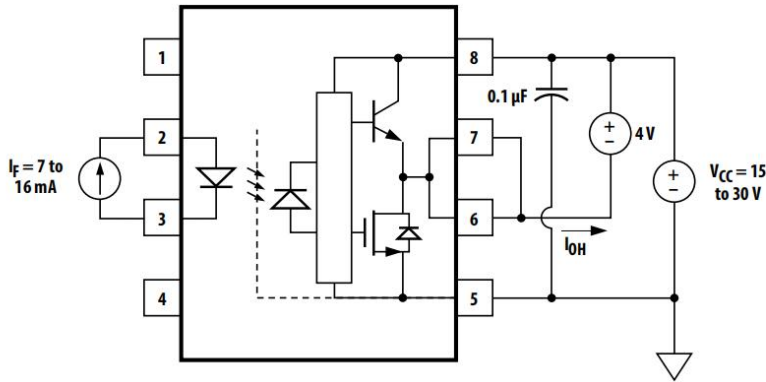

Figure 18:  $I_{OL}$  Test Circuit

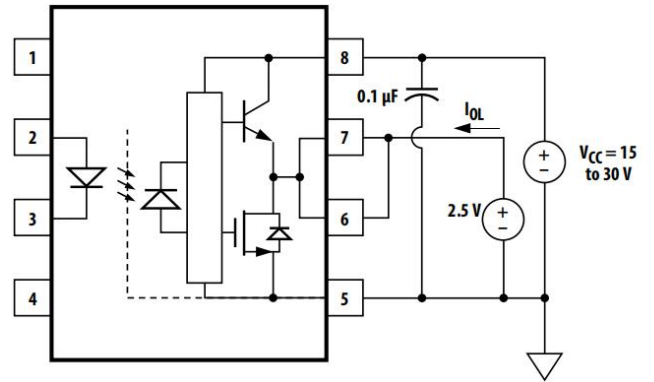

Figure 19:  $V_{OH}$  Test Circuit

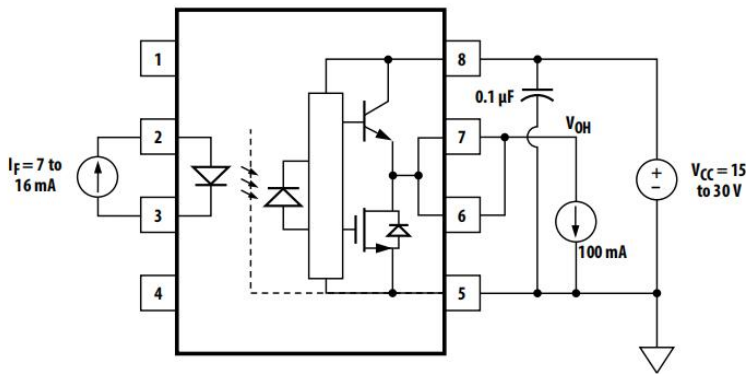

Figure 20:  $V_{OL}$  Test Circuit

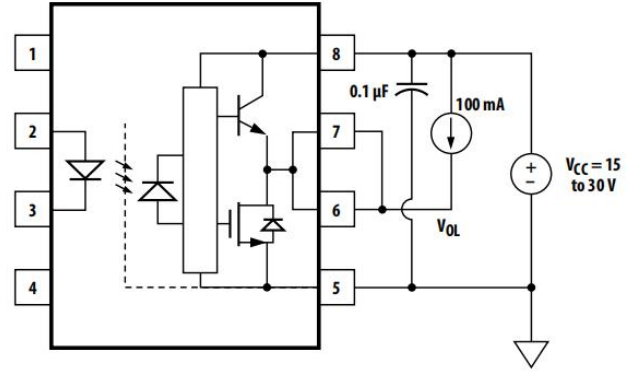

Figure 21:  $I_{FLH}$  Test Circuit

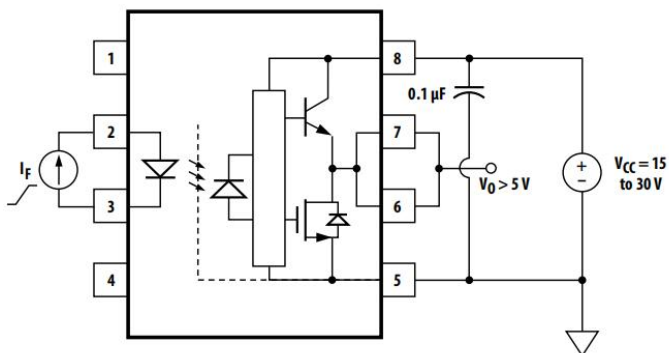

Figure 22: UVLO Test Circuit

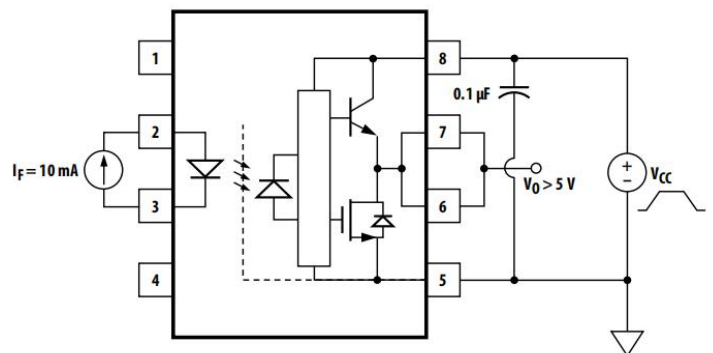

Figure 23:  $t_{PLH}$ ,  $t_{PHL}$ ,  $t_r$ , and  $t_f$  Test Circuit and Waveforms

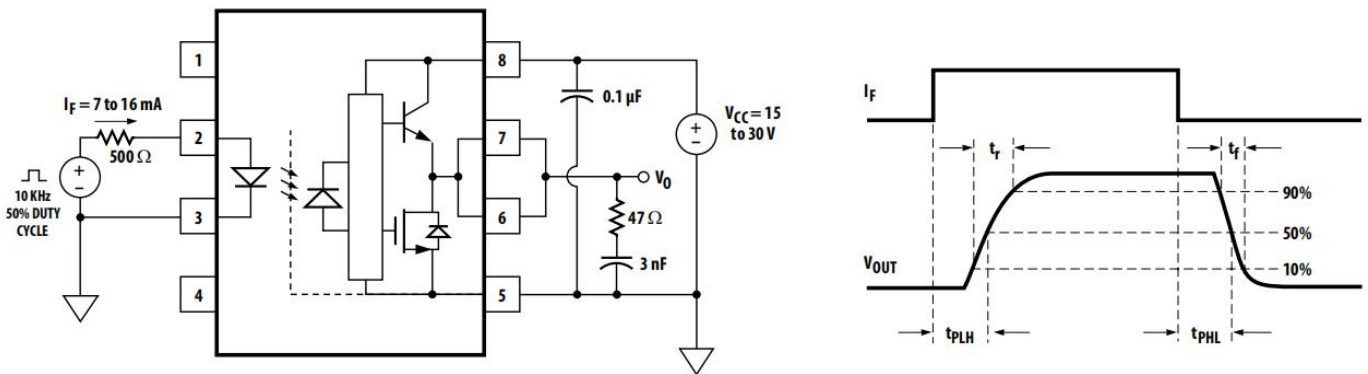
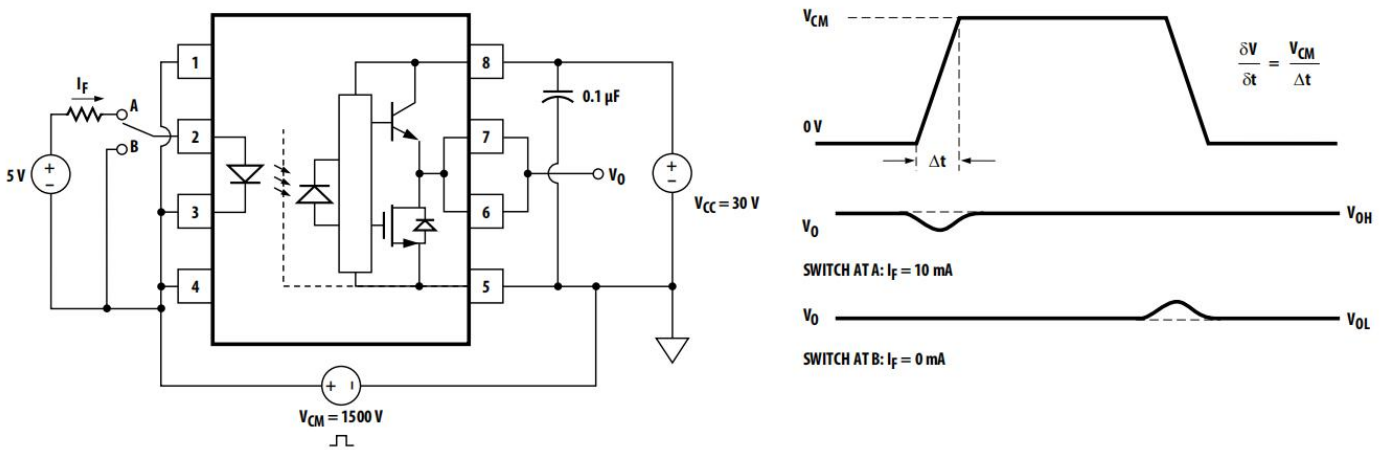

Figure 24: CMR Test Circuit and Waveforms



单击下面可查看定价，库存，交付和生命周期等信息

[>>ORIENT\(奥伦德\)](#)