



FEATURES

- 1. Slim size (width 5 mm .197 inch, height 12.5 mm .492 inch) permits higher density mounting**
Despite the slim 5 mm width, the 20 mm length is still compact and the 12.5 mm profile is low. Even when a socket is used, the height is still only 18 mm. Suitable for high-density mounting, these relays enable device size smaller.
- 2. Nominal operating power: High sensitivity of 120mW**
Enables smaller power supplies, facilitates energy saving applications, and contributes to device size smaller.

- 3. Control from low level loads to 5 A**
Use of gold-clad twin contacts enables control of low level loads down to 100 mV 100 μ A and up to 5 A 250 V AC and 30 V DC.
- 4. Reinforced according to IEC1131-2 (TÜV)**
PAD type Min. 3.0 mm/
PA type Min. 2.0 mm clearance
PAD type Min. 3.0 mm/
PA type Min. 3.0 mm creepage distance
- 5. High surge breakdown voltage (4000 V) and high breakdown voltage (2000 V)**
Between contacts and coil of 2,000 V and surge resistance of 4,000 V work to prevent controller malfunctions caused by noise and surges.
- 6. Outstanding vibration and shock resistance.**
Functional shock resistance: 147 m/s²
Functional vibration resistance: 10 to 55 Hz (at double amplitude of 2.5 mm .098 inch)
Keeps equipment from misoperation due to vibration and shock.

- Can be used as mounted on control panel doors.
- 7. Sealed construction allows automatic washing.**
 - 8. SIL (single in line) terminal layout**
 - 9. Complies with safety standards**
Complies with Japanese Electrical Appliance and Material Safety Law, and certified by UL, CSA, and TÜV.
 - 10. Sockets are also available**

TYPICAL APPLICATIONS

- 1. Industrial equipment, office equipment**
- 2. Measuring devices and test equipment**
- 3. Interface relays for programmable controllers**
- 4. Output relays in small devices such as timers, counters, sensors, and temperature controllers.**

ORDERING INFORMATION

PA(D) 1a -

Contact arrangement
1a: 1 Form A (Bifurcated)

Coil voltage (DC)
4.5, 5, 6, 9, 12, 18, 24V

Notes: 1) The PAD type offers slightly higher clearance (min. 3.0 mm) and creepage distance (min. 3.0 mm).
2) UL/CSA, TÜV approved type is standard.

TYPES

Contact arrangement	Nominal coil voltage	Part No.	
		PA type	PAD type
1 Form A	4.5V DC	PA1a-4.5V	—
	5.0V DC	PA1a-5V	PAD1a-5V
	6.0V DC	PA1a-6V	—
	9.0V DC	PA1a-9V	—
	12.0V DC	PA1a-12V	PAD1a-12V
	18.0V DC	PA1a-18V	PAD1a-18V
	24.0V DC	PA1a-24V	PAD1a-24V
	24.0V DC	PA1aS-24V	—

Standard packing: Carton: 25 pcs.; Case: 1,000 pcs.
* For sockets, see page 6.

PA(D)

RATING

1. Coil data

1) PA type

Nominal coil voltage	Pick-up voltage (at 20°C 68°F)	Drop-out voltage (at 20°C 68°F)	Nominal operating current [$\pm 10\%$] (at 20°C 68°F)	Coil resistance [$\pm 10\%$] (at 20°C 68°F)	Nominal operating power	Max. allowable voltage (at 20°C 68°F)
4.5V DC	70%V or less of nominal voltage (Initial)	5%V or more of nominal voltage (Initial)	26.0mA	169 Ω	120mW	120%V of nominal voltage
5V DC			24.0mA	208 Ω		
6V DC			20.0mA	300 Ω		
9V DC			13.3mA	675 Ω		
12V DC			10.0mA	1,200 Ω		
18V DC			6.7mA	2,700 Ω		
24V DC			7.5mA	3,200 Ω	180mW	
24V DC			5.0mA	4,800 Ω	120mW	

2) PAD type

Nominal coil voltage	Pick-up voltage (at 20°C 68°F)	Drop-out voltage (at 20°C 68°F)	Nominal operating current [$\pm 10\%$] (at 20°C 68°F)	Coil resistance [$\pm 10\%$] (at 20°C 68°F)	Nominal operating power	Max. allowable voltage (at 20°C 68°F)
5V DC	70%V or less of nominal voltage (Initial)	5%V or more of nominal voltage (Initial)	36.0mA	139 Ω	180mW	120%V of nominal voltage
12V DC			15.0mA	800 Ω		
18V DC			10.0mA	1,800 Ω		
24V DC			7.5mA	3,200 Ω		

2. Specifications

Characteristics	Item	Specifications	
		PA type	PAD type
Contact	Arrangement	1 Form A	
	Initial contact resistance, max.	Max. 30 m Ω (By voltage drop 6 V DC 1A)	
	Contact material	Au-clad AgNi type	
Rating	Nominal switching capacity (resistive load)	5 A 250 V AC, 5 A 30 V DC	3 A 250 V AC, 3 A 30 V DC
	Max. switching power (resistive load)	1,250 VA, 150 W	750 VA, 90 W
	Max. switching voltage	250 V (AC), 110 V (DC)	
	Max. switching current	5 A	3 A
	Nominal operating power	120 mW (5 to 24 V DC), 180 mW (24 V DC)	180 mW
	Min. switching capacity (Reference value) ^{*1}	100 μ A 100mV DC	
Electrical characteristics	Insulation resistance (Initial)	Min. 1,000M Ω (at 500V DC) Measurement at same location as "Initial breakdown voltage" section.	
	Breakdown voltage (Initial)	Between open contacts	1,000 Vrms for 1min. (Detection current: 10mA.)
		Between contact and coil	2,000 Vrms for 1min. (Detection current: 10mA.)
	Surge breakdown voltage (Initial)	Between contacts and coil ^{*2}	4,000 V
	Temperature rise (at 20°C 68°F)	Max. 45°C (By resistive method, nominal voltage applied to the coil, nominal switching capacity.)	
	Operate time (at nominal voltage) (at 20°C 68°F)	Max. 10 ms	
Release time (at nominal voltage) (at 20°C 68°F)	Max. 5 ms		
Mechanical characteristics	Shock resistance	Functional	Min. 147 m/s ² (Half-wave pulse of sine wave: 11 ms; detection time: 10 μ s.)
		Destructive	Min. 980 m/s ² (Half-wave pulse of sine wave: 6 ms.)
	Vibration resistance	Functional	10 to 55 Hz at double amplitude of 2.5 mm (Detection time: 10 μ s.)
		Destructive	10 to 55 Hz at double amplitude of 3.5 mm
Expected life	Mechanical	Min. 2 $\times 10^7$ (at 180 times/min.)	
	Electrical	3 A 250 V AC, 30 V DC	Min. 1 $\times 10^5$ operations (at 20 times/min.)
5 A 250 V AC, 30 V DC		Min. 5 $\times 10^4$ operations (at 20 times/min.)	—
Conditions	Conditions for operation, transport and storage ^{*3}	Ambient temperature: -40°C to 70°C -40°F to 158°F; Humidity: 5 to 85% R.H. (Not freezing and condensing at low temperature)	
	Max. operating speed (at rated load)	20 times/min.	
Unit weight	Approx. 3 g .15 oz		

Notes:

*1 This value can change due to the switching frequency, environmental conditions, and desired reliability level, therefore it is recommended to check this with the actual load.

*2 Wave is standard shock voltage of $\pm 1.2 \times 50 \mu$ s according to JEC-212-1981.

*3 Refer to "6. Usage, Storage and Transport Conditions" in [AMBIENT ENVIRONMENT](#) section in [Relay Technical Information](#).

REFERENCE DATA

1. Max. switching capacity

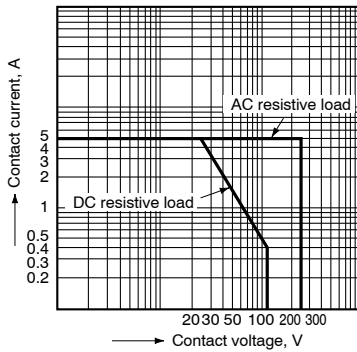

2. Life curve

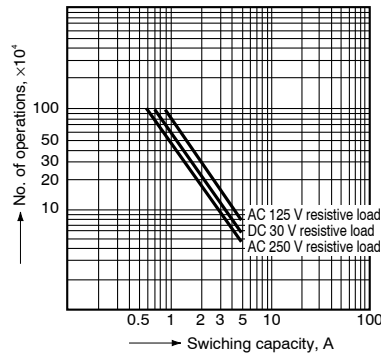

3.-(1) Coil temperature rise (120 mW)

Tested sample: PA1a-12V
Measured portion: Inside the coil
Ambient temperature: 20°C 68°F

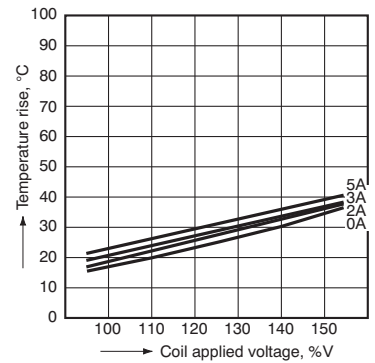

3.-(2) Coil temperature rise (180 mW)

Tested sample: PA1a-24V
Measured portion: Inside the coil
Ambient temperature: 20°C 68°F

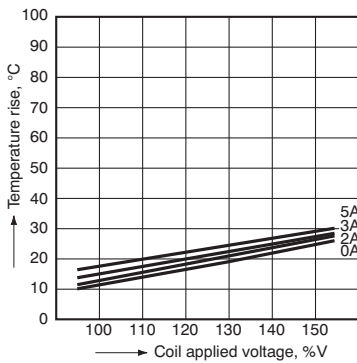

4.-(1) Operate & release time (120 mW)

Tested sample: PA1a-12V, 20 pcs.

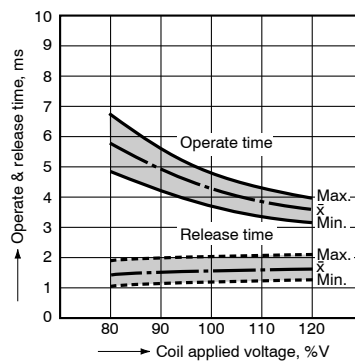

4.-(2) Operate & release time (180 mW)

Tested sample: PA1a-24V, 20 pcs.

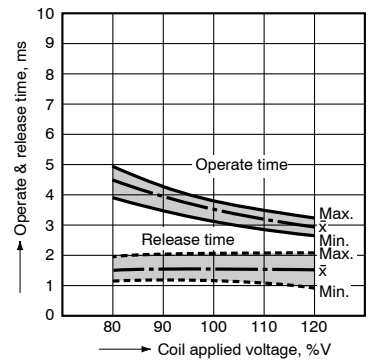

5. Ambient temperature characteristics

Tested sample: PA1a-12V, 6 pcs.

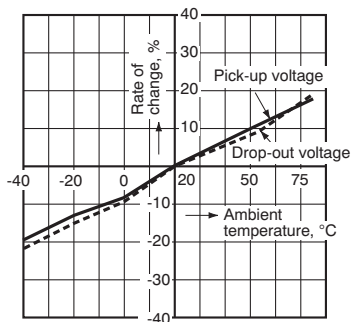

6. Malfunctional shock

Tested sample: PA1a-12V, 6 pcs.

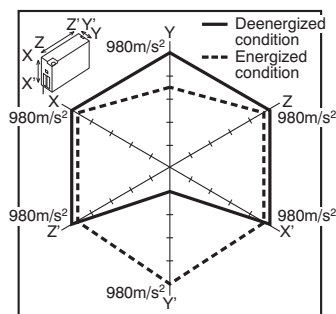

PA(D)

DIMENSIONS (mm inch)

Download [CAD Data](#) from our Web site.

[CAD Data](#)

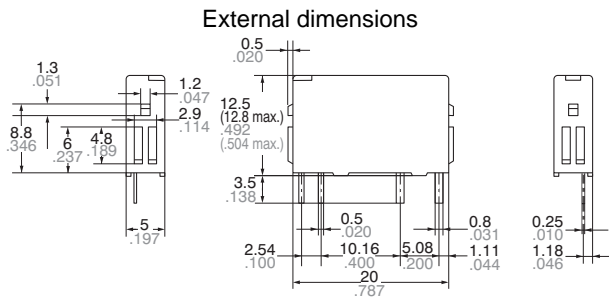

General tolerance: $\pm 0.3 \pm .012$

PC board pattern (Bottom view)

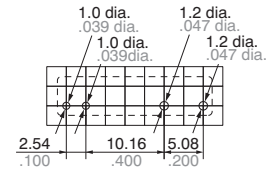

Tolerance: $\pm 0.1 \pm .004$

Schematic (Bottom view)

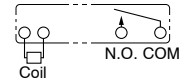

SAFETY STANDARDS

Certification authority	File No.	PA type rating	PAD type rating	Remarks
UL/C-UL (Recognized)	E43149	3A 250V AC (1×10^5 operations) 3A 30V DC (1×10^5 operations) 5A 250V AC (5×10^4 operations) 5A 250V AC (5×10^4 operations)	3A 250V AC (1×10^5 operations) 3A 30V DC (1×10^5 operations)	—
CSA (Certified)	LR26550 etc.	3A 250V AC (1×10^5 operations) 3A 30V DC (1×10^5 operations) 5A 250V AC (5×10^4 operations) 5A 30V DC (5×10^4 operations)	3A 250V AC (1×10^5 operations) 3A 30V DC (1×10^5 operations)	—
TÜV (Certified)	B 12 01 13461 316	IEC1131-2 Reinforced 3A 250V AC ($\cos\phi=1.0$) (1×10^5) 3A 30V AC (0ms) (1×10^5) 5A 250V AC ($\cos\phi=1.0$) (5×10^4) 5A 30V AC (0ms) (5×10^4)	IEC1131-2 Reinforced 3A 250V AC ($\cos\phi=1.0$) (1×10^5) 3A 30V AC (0ms) (1×10^5)	—

NOTES

1. If it includes ripple, the ripple factor should be less than 5%.
2. Specification values for pick-up and drop-out voltages are for the relay mounting with its terminals below.

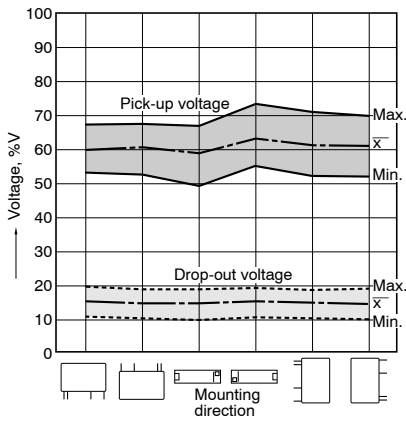

3. When mounting the relays within 1 mm .039 inch, please notice the condition below.

- 1) Mount the relays in the same direction.

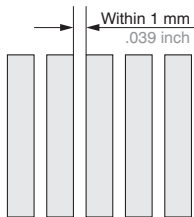

- 2) Coil terminals (Terminal No. 1 & 2) polarity should be arranged in the same direction.

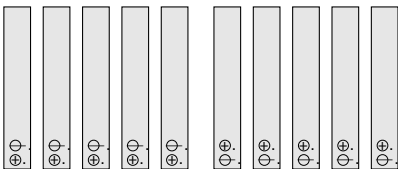

- 3) Allowable contact current is 2 A.
- 4) About the electrical life for close mounting, please refer to data below.

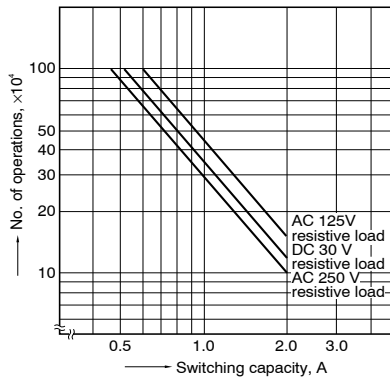
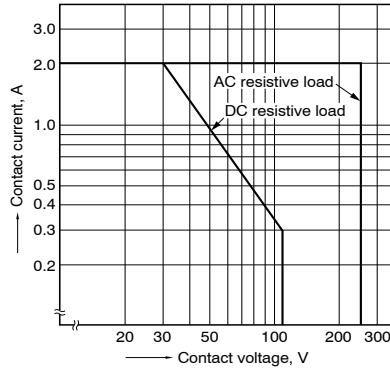

4. Soldering conditions
Please obey the following conditions when soldering automatically:
(1) Preheating: Within 120°C 248°F (bottom of the PC board) and within 120 seconds
(2) Soldering iron: 260°C±5°C 500°F±41°F (solder temperature) and within 6 seconds (soldering time)

For Cautions for Use, see [Relay Technical Information](#).

TYPES

Product name	Part No.
Standard type terminal socket	PA1a-PS
Self clinching type terminal socket	PA1a-PS-H



Standard type terminal socket



Self clinching type terminal socket

DIMENSIONS (mm inch)

Download [CAD Data](#) from our Web site.

Standard type terminal socket

[CAD Data](#)

External dimensions

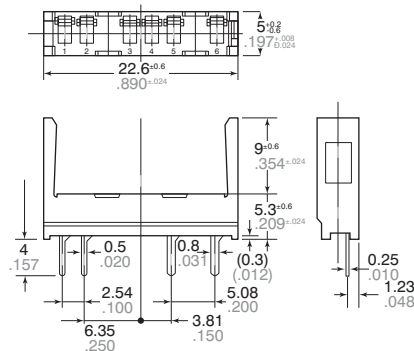

General tolerance: $\pm 0.3 \pm 0.12$

PC board pattern (Bottom view)

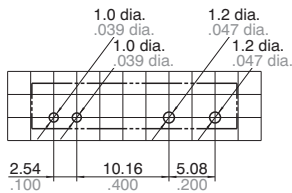

Tolerance: $\pm 0.1 \pm 0.04$

Self clinching type terminal socket

[CAD Data](#)

External dimensions

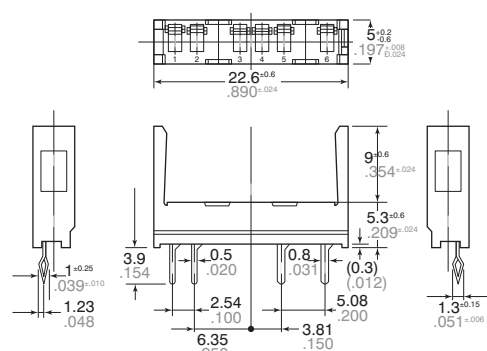

General tolerance: $\pm 0.3 \pm 0.12$

PC board pattern (Bottom view)

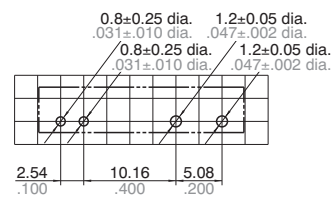

INSTALLING AND REMOVING

Installing and removing the relay

1) Firmly insert the relay into the socket with the terminals going in the direction of the blade receptacles.

(1) Insert the removal key into the socket slots.

2) The relay can be easily removed using the removal key (APA801).

(2) Pull the removal key up to remove the relay.

(3) Slide the removal key off of the relay.

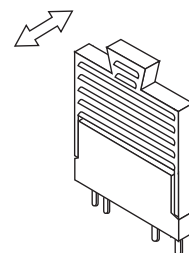
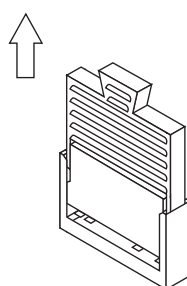
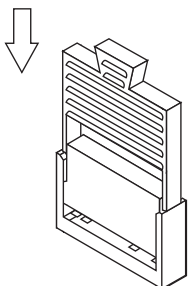

单击下面可查看定价，库存，交付和生命周期等信息

[>>Panasonic\(松下\)](#)