



NEW! Special Function Motor Drivers

AN41908A Lens Driver

AN41919A DC Iris Driver

Panasonic Special Function Motor Drivers For Network and Security Cameras



**Dome Type Cameras
(Iris Servo for Hall Sensor)**



**Box Type Camera
(Iris Servo for Dumping Coil)**

	Type	Function	Package (Chip size)	Status
Lens Driver for Dome type	AN41908A	5ch motor drive controller (Zoom 2ch + Focus 2ch + Iris servo for hall sensor 1ch)	QFN44 (6mm × 6mm)	Under MP
DC Iris Driver for Box type	AN41919A	1ch Iris controller (Iris servo for dumping coil 1ch)		

Panasonic AN41908A Lens Driver for Dome Type Camera (Iris Servo for Hall Sensor)



Block Diagram of Network Camera (Hall Sensor)

Block diagram

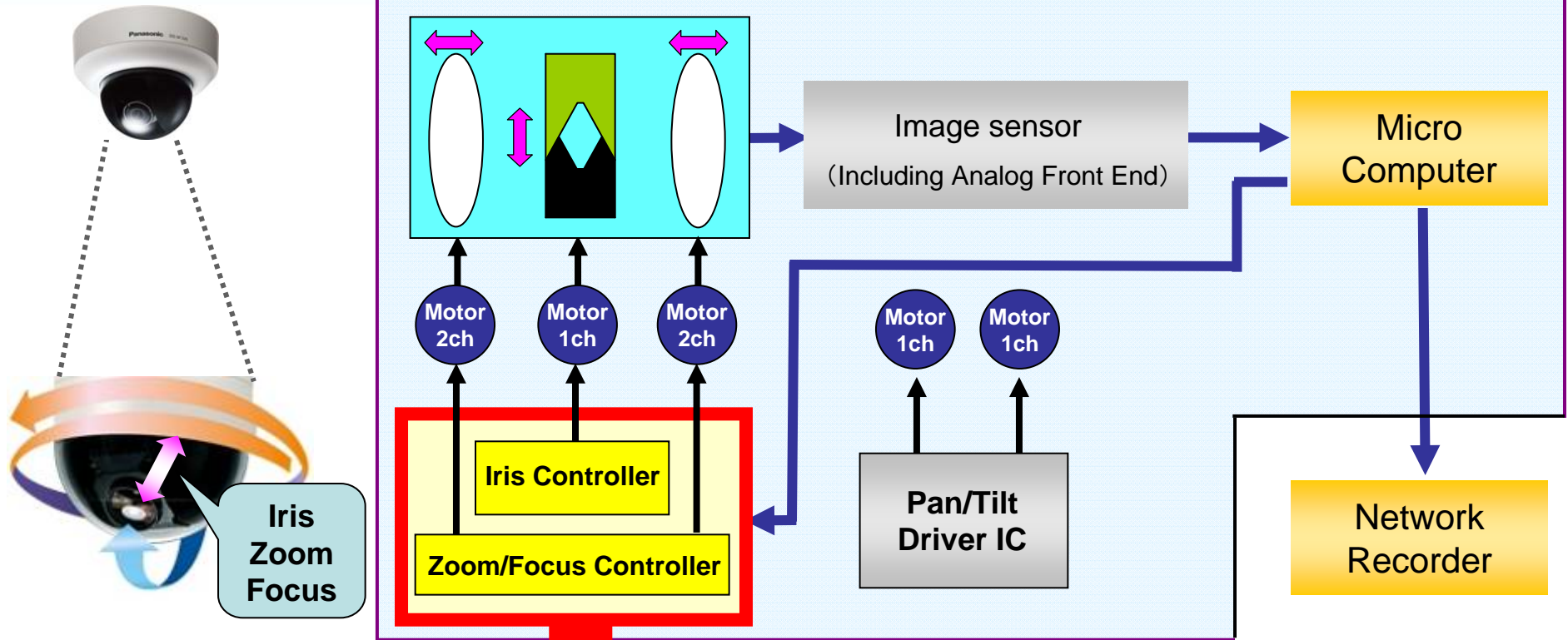

**Single chip solution
Lens Driver
AN41908A**

Panasonic AN41908A Block Diagram

To Integrate Iris Control Function on Zoom & Focus Driver

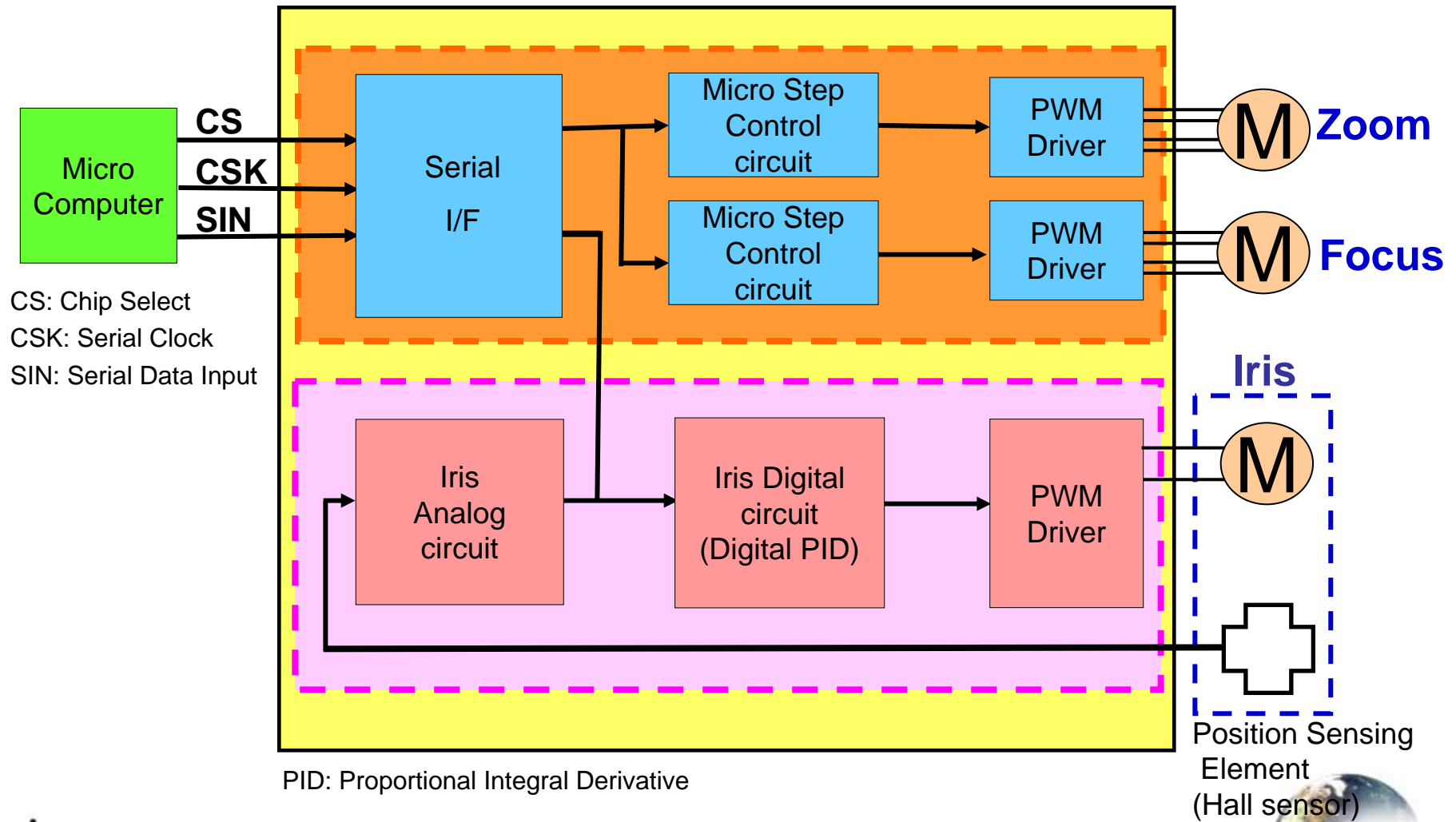

Panasonic AN41908A Single Chip Advantages

- PCB Space Reduction
- Reduced Design-In Time
- Low Acoustic Noise
- Low Power Consumption

PCB Space Reduction

Company A

Total Area = 381mm²

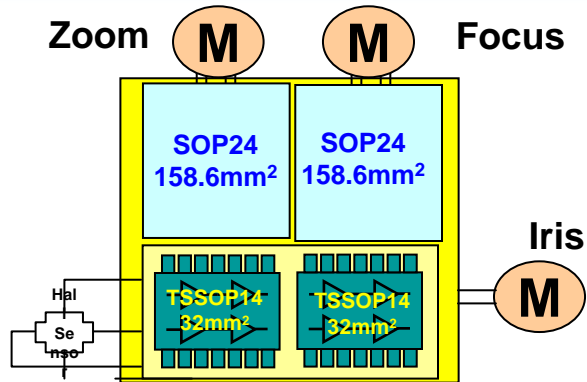

90.5% Reduction

8 OP Amps and external parts are needed for Iris function...

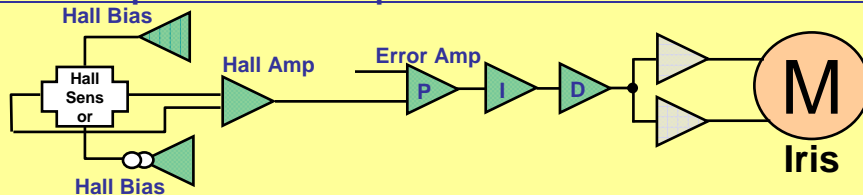

Company B

Total Area = 162mm²

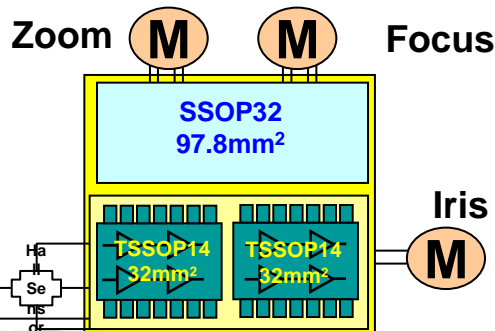

78% Reduction

AN41908A

1Chip LSI of Zoom, Focus and Iris function

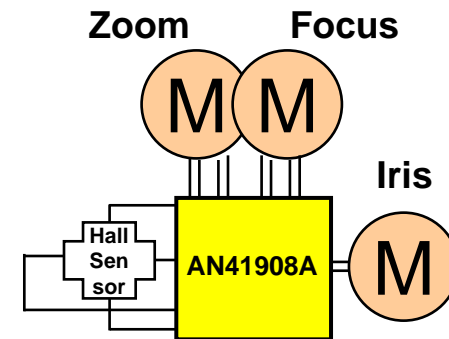

Total Area = 36mm²
(About 80-90% reduction!!)

Advantage for

- Small Camera design
- PCB cost reduction

Reduced Design-In Time

Easy Adjustment of Iris Circuit

Existing system

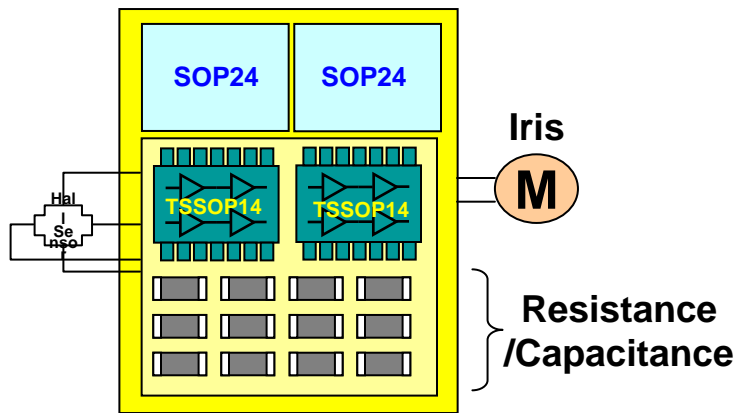

AN41908A

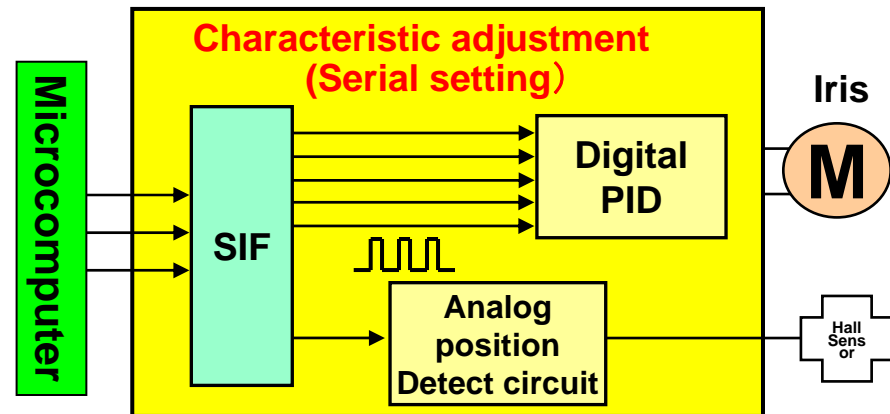

SIF: Serial Inter Face

PID: Proportion / integral calculus / differential calculus 3 elements digital control system

Inconvenient...

You needed to adjust Iris circuit when you start to design camera...

You needed to change external resistance and capacitance for Iris adjustment...

Improved !!

Software can arrange the circuit by SIF because of built-in digital PID

Low Noise Micro Step Drive for Zoom and Focus

Less Acoustic Noise by Motor Tolerance Correction Function

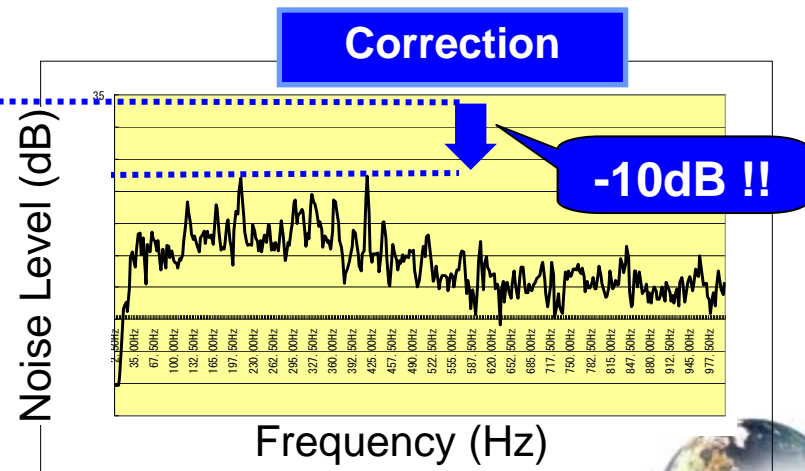
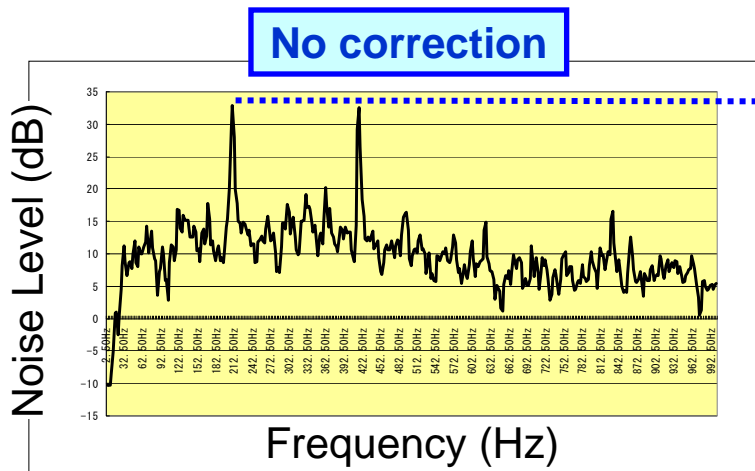
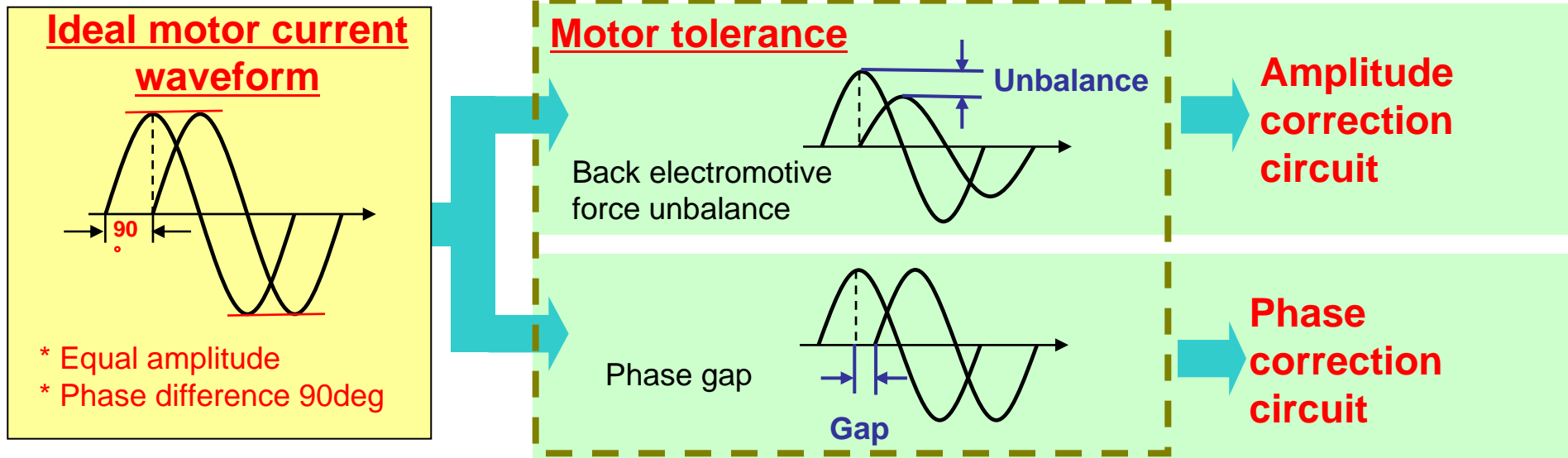

Low Power Consumption

50% power reduction by PWM driving system !!

(Compared with Linear driving system)

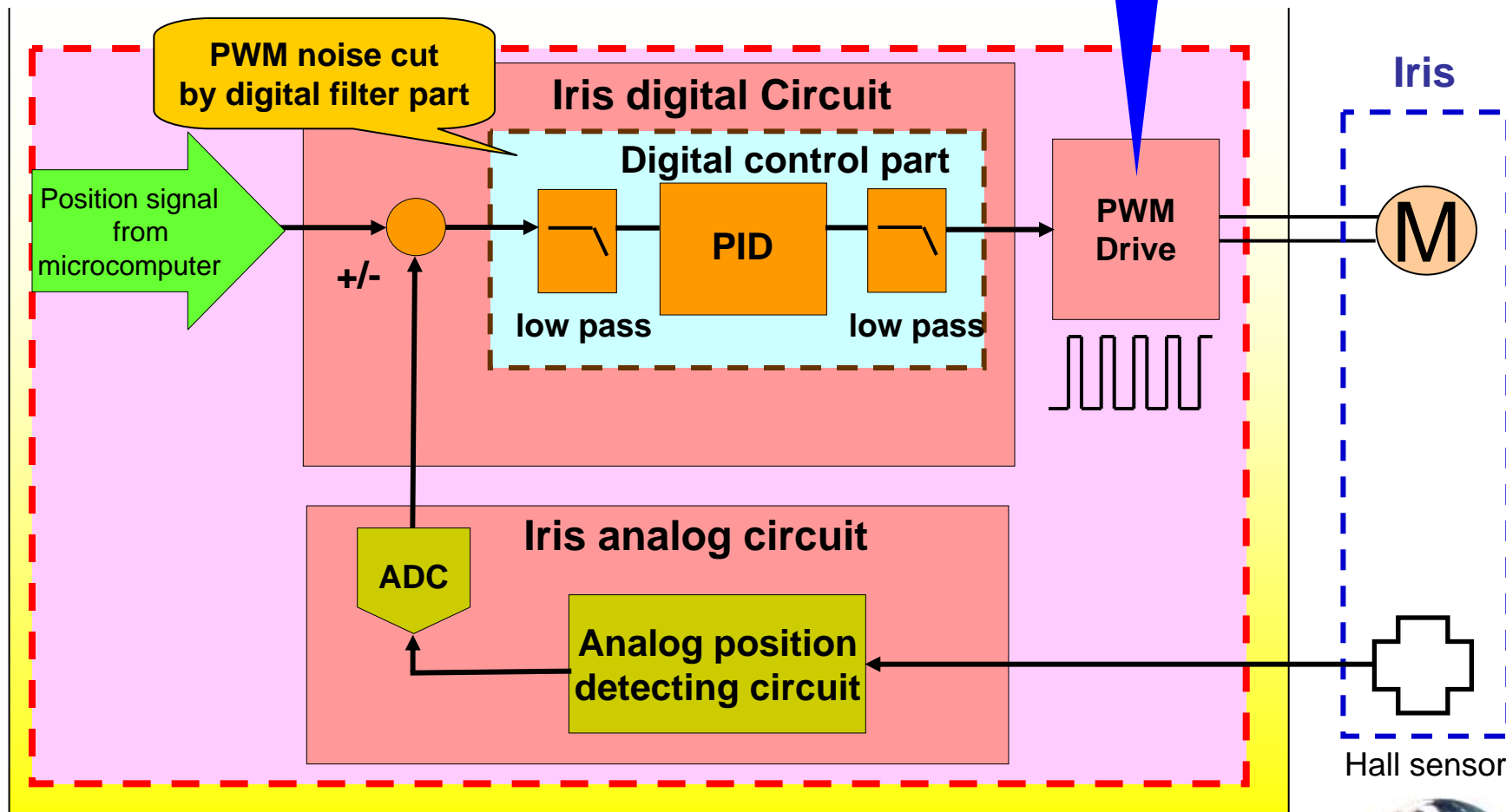

Panasonic AN41908A Application Circuit

Panasonic can prepare evaluation board and more specific application notes.

Overview

AN41908A is a lens motor driver IC for camcorder and security-camera featuring the functions of Iris control. Voltage drive system and several torque ripple correction techniques enable super- low noise microstep drive.

Features

- Voltage drive system 256-step microstep drivers (2 systems)
- Built-in Iris controller
- Motor control by 4-line serial data communication
- 2 systems of open-drain for driving LED

Applications

- Camcorders, Security Cameras

Package

- 44 pin Plastic Quad Flat Non-leaded Package

Type

- Bi-COMS IC

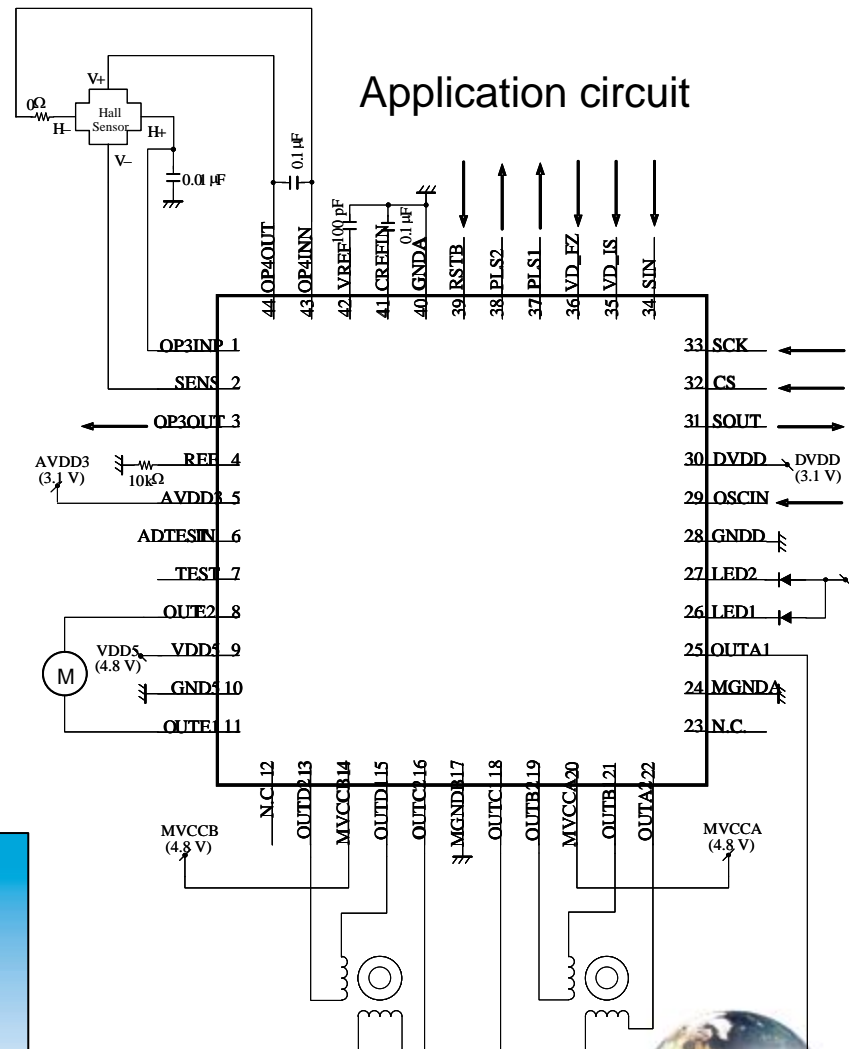

Evaluation Board

Connection for quick start-up

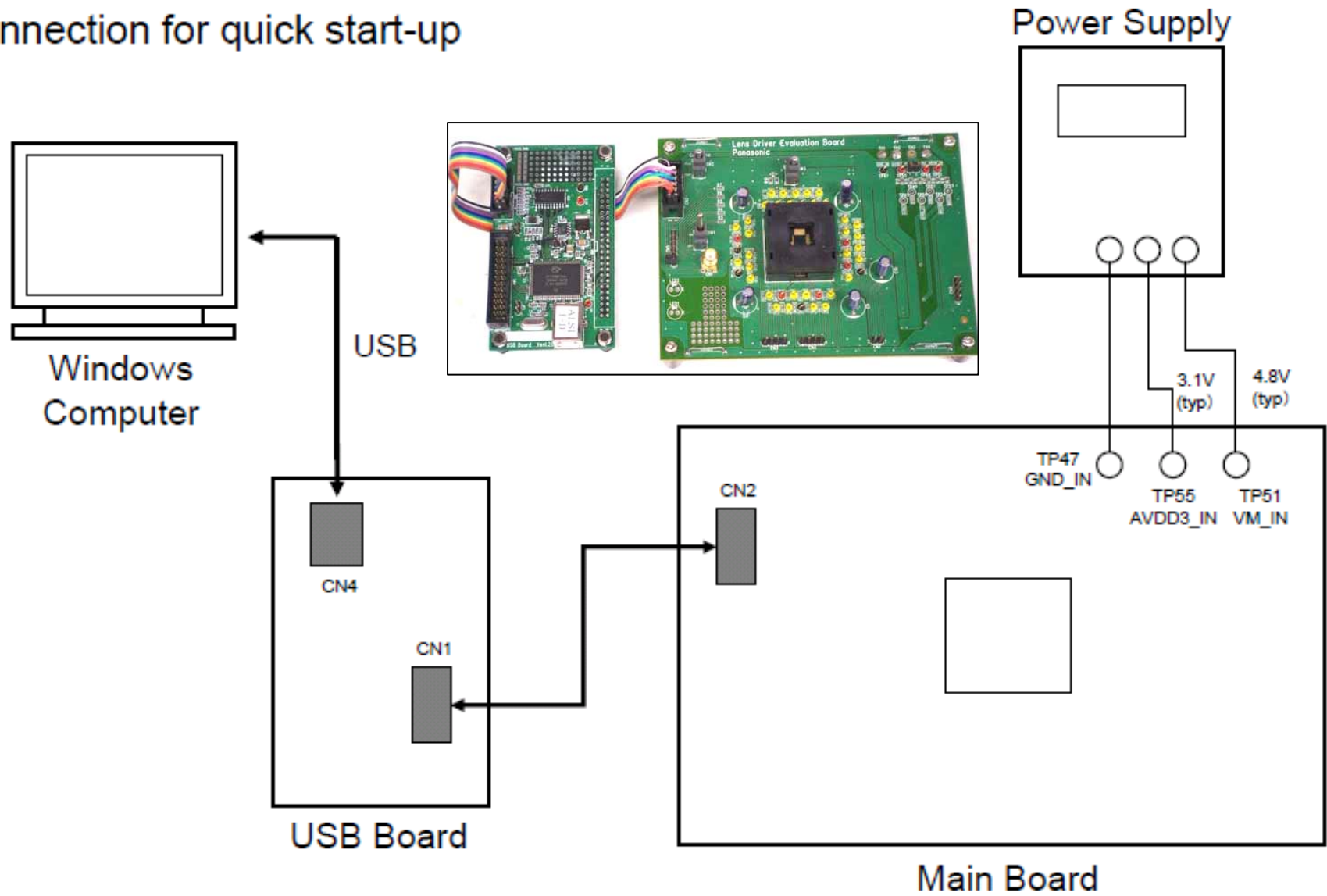

Panasonic AN41919A DC Iris Driver for Box Type Camera

(Iris Servo for Dumping Coil)



Block Diagram of Network Camera (DC-Iris)

Block diagram

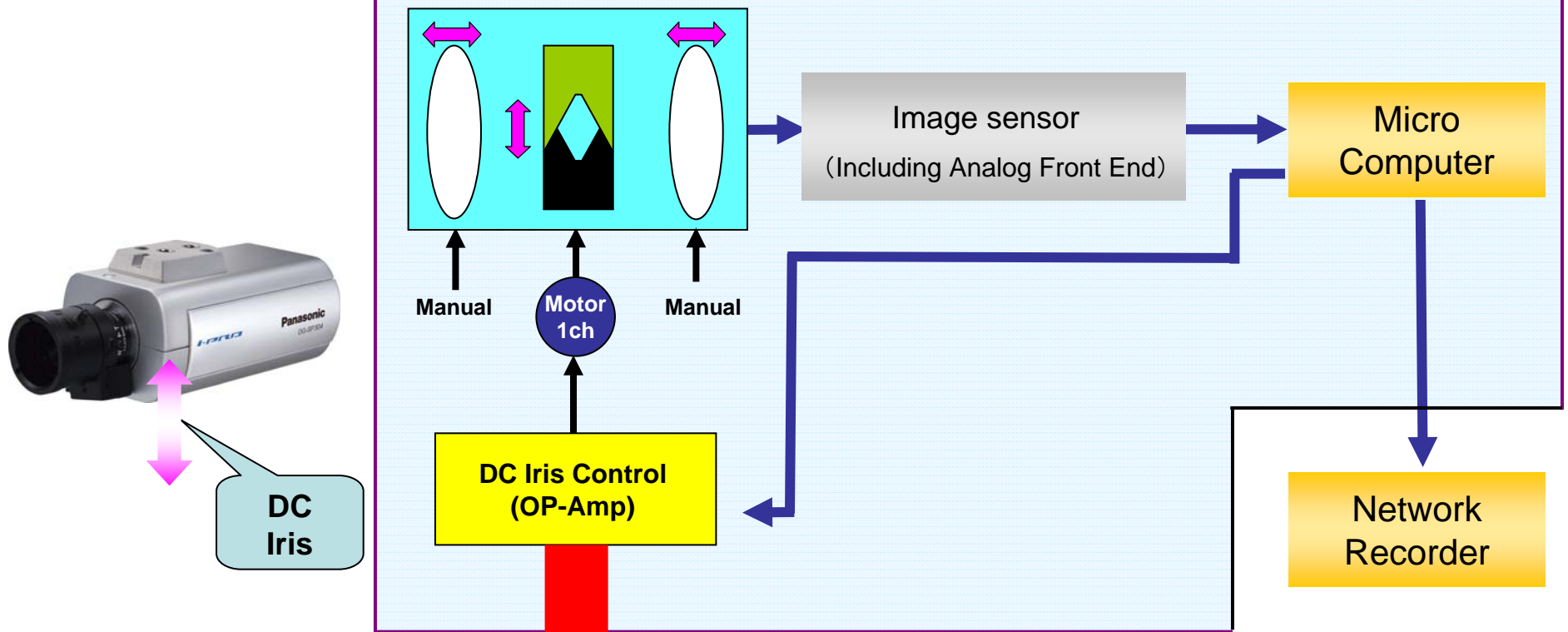

**Single chip solution
DC Iris Driver
AN41919A**

**Integration,
Industry's first !!**

Panasonic AN41919A Block Diagram

Contributes to Sets' Miniature Design.

AN41919A

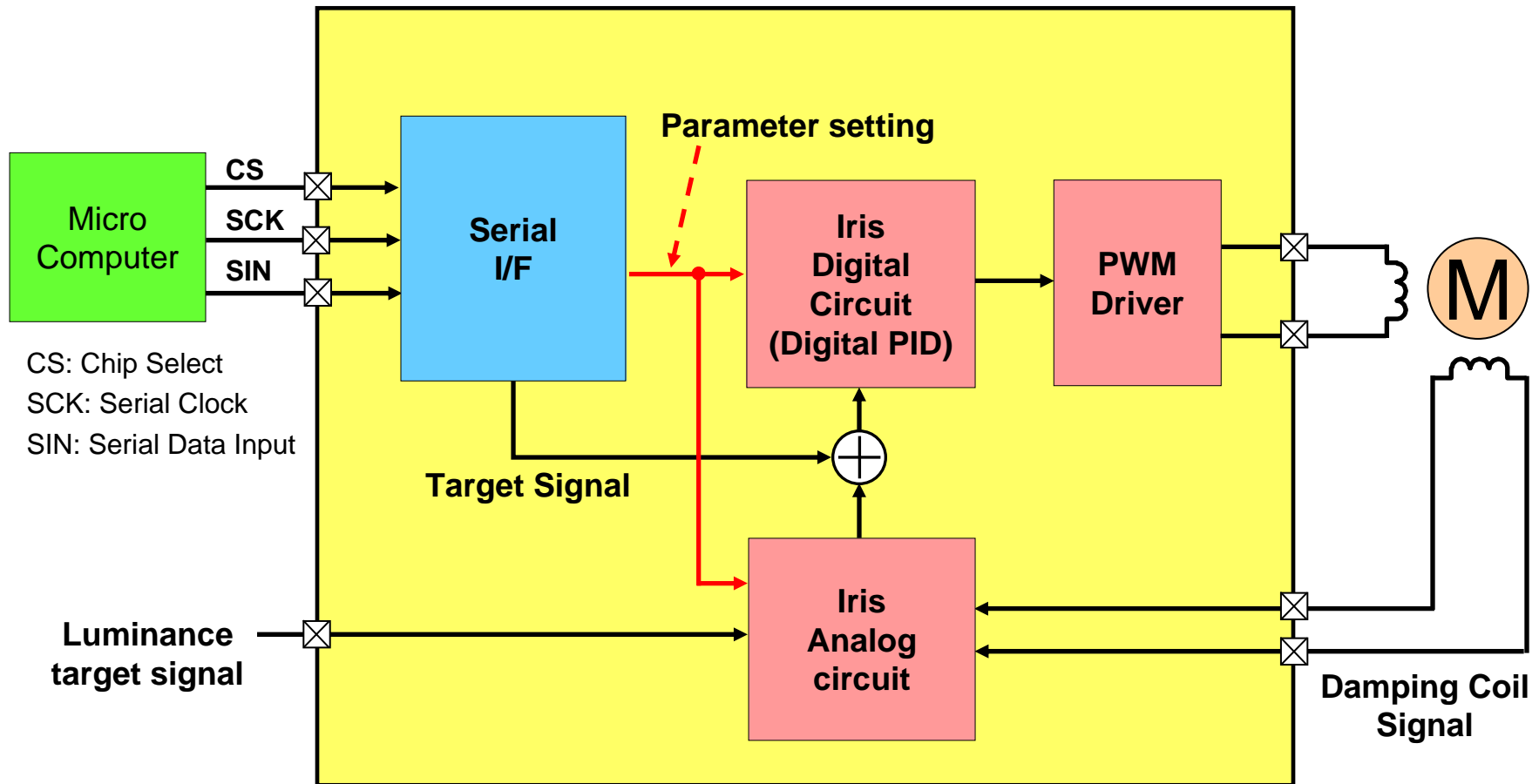

Single Chip Solution of DC Iris Function

Panasonic AN41919A Advantages

- **Reduced Design-In Time**
- **Low Power Consumption**

Reduced Design-In Time

Easy Adjustment of Iris Circuit

Existing System

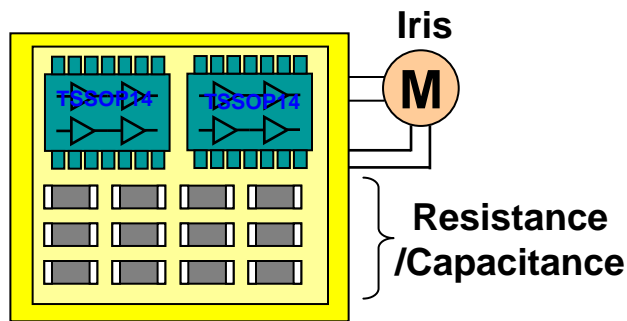

AN41919A

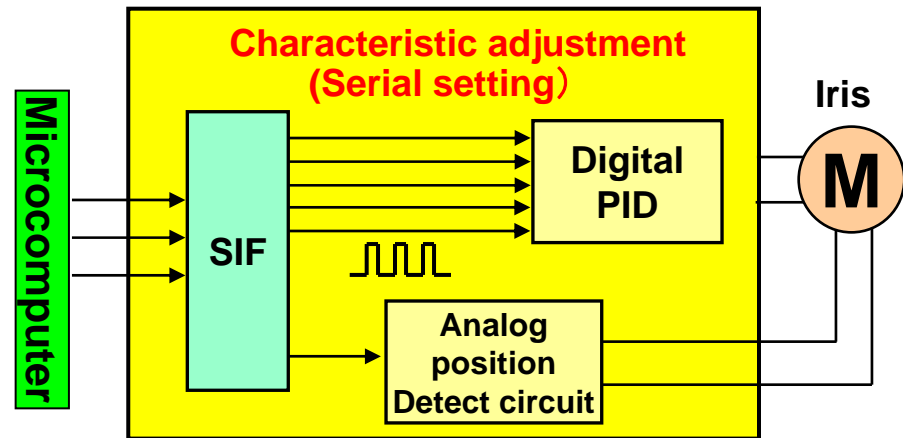

SIF: Serial Inter Face

PID: Proportion / integral calculus / differential calculus 3 elements digital control system

Inconvenient...

You needed to adjust Iris circuit when you start to design camera...

You needed to change external resistance and capacitance for Iris adjustment...

Improved !!

Software can arrange the circuit by SIF because of built-in digital PID

Low Power Consumption

50% Power Reduction by PWM Driving System

(Compared with Linear driving system)

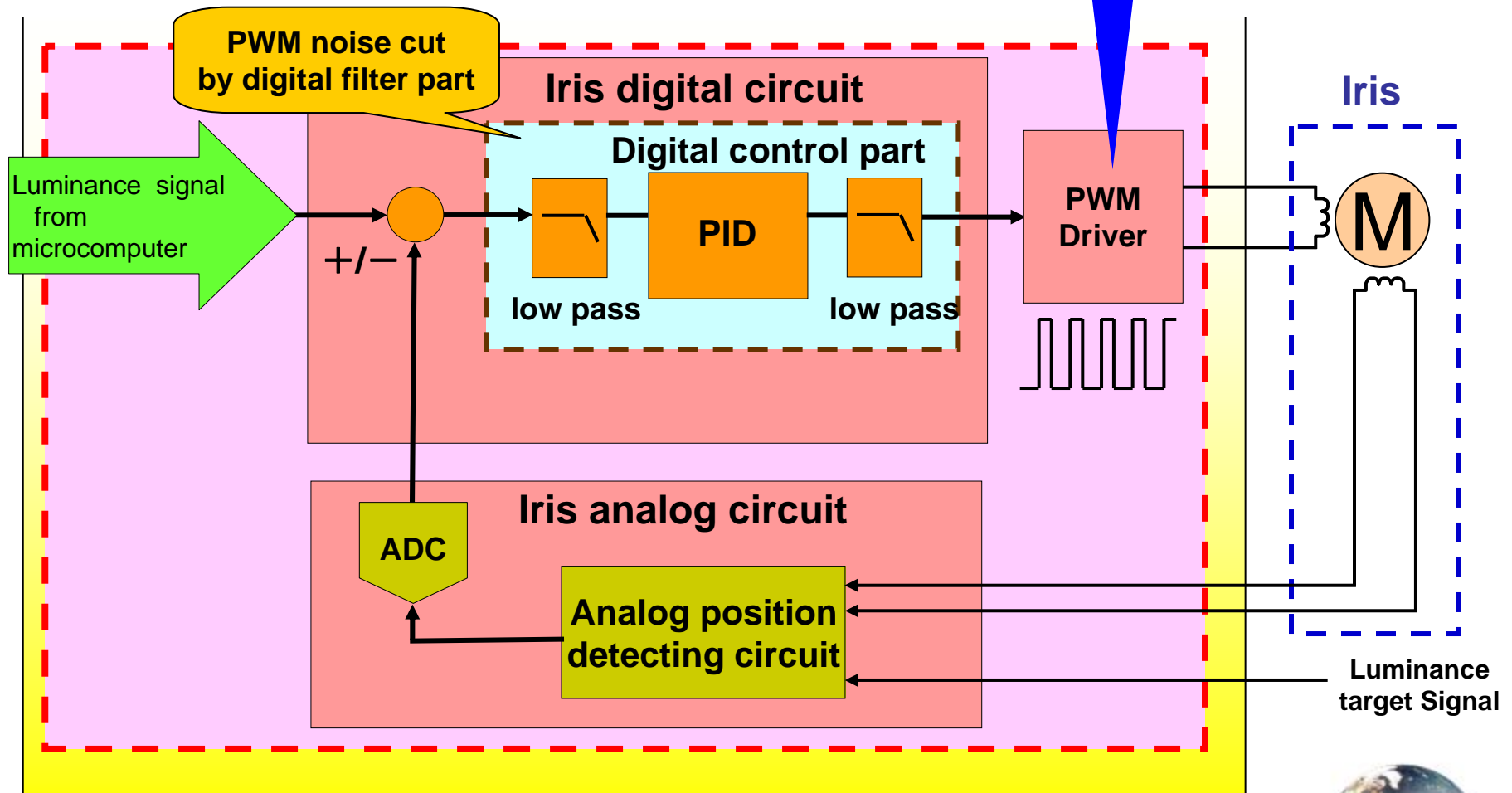

Panasonic AN41919A Application Circuit

Panasonic can prepare evaluation board and more specific application notes.

Overview

AN41919A is a iris control LSI for IP-camera and security-camera.

Features

- Built-in Iris controller
- Iris control by 4-line serial data communication

Applications

- IP-camera, Security-camera

Package

- 44 pin Plastic Quad Flat Non-leaded Package

Type

- Bi-COMS IC

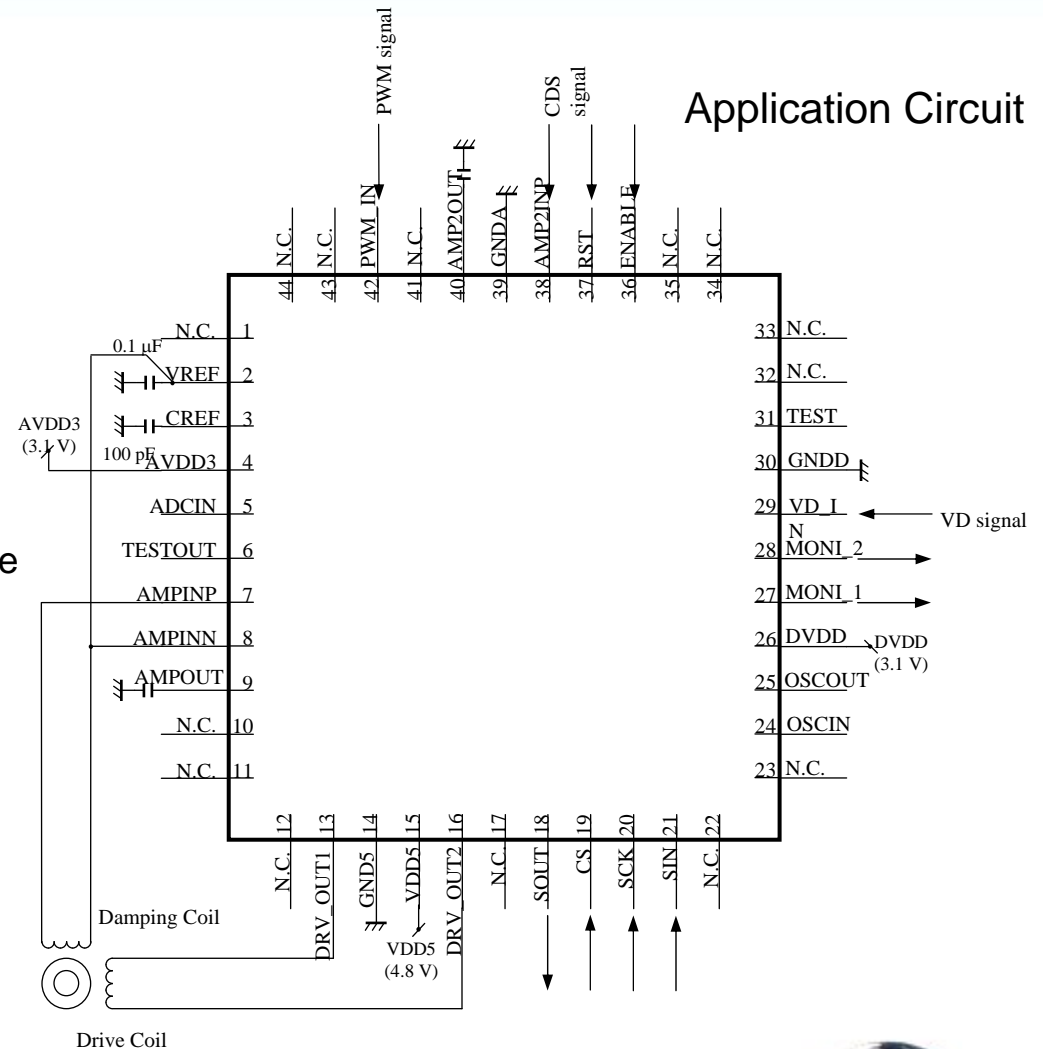

Evaluation Board

Connection for quick start-up

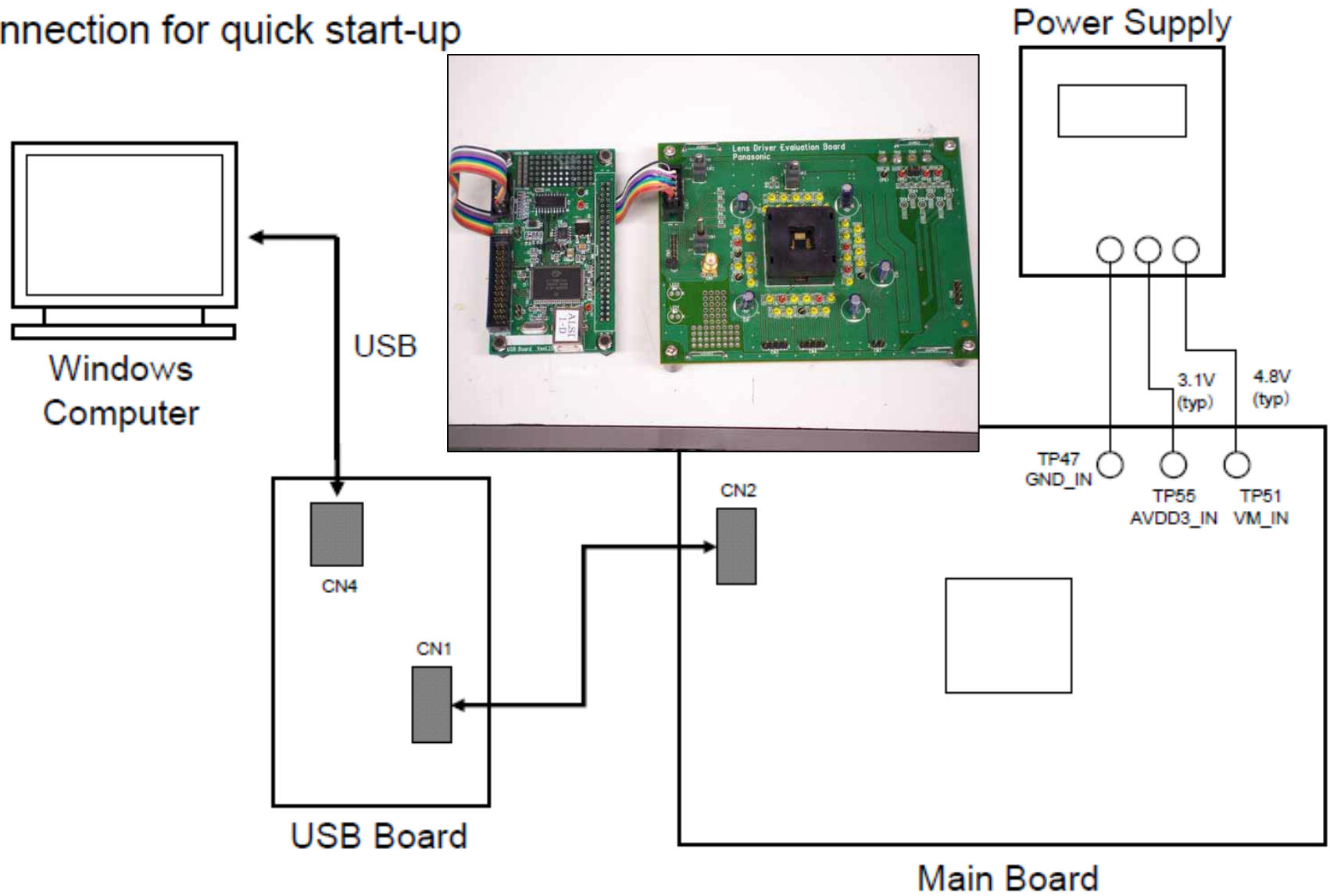



NEW! Special Function Motor Drivers

AN41908A Lens Driver

AN41919A DC Iris Driver

单击下面可查看定价，库存，交付和生命周期等信息

[>>Panasonic\(松下\)](#)