

Notification about the transfer of the semiconductor business

The semiconductor business of Panasonic Corporation was transferred on September 1, 2020 to Nuvoton Technology Corporation (hereinafter referred to as "Nuvoton"). Accordingly, Panasonic Semiconductor Solutions Co., Ltd. became under the umbrella of the Nuvoton Group, with the new name of Nuvoton Technology Corporation Japan (hereinafter referred to as "NTCJ").

In accordance with this transfer, semiconductor products will be handled as NTCJ-made products after September 1, 2020. However, such products will be continuously sold through Panasonic Corporation.

Publisher of this Document is NTCJ.

If you would find description "Panasonic" or "Panasonic semiconductor solutions", please replace it with NTCJ.

※ Except below description page

"Request for your special attention and precautions in using the technical information and semiconductors described in this book"

Nuvoton Technology Corporation Japan

Driver IC for single phase Brushless Motor

FEATURES

- Supply voltage range: 5.0 V ~ 28 V
- Auto phase shift correction with built-in Soft Switching function
- Wide range operation (12V/24V)
- Speed Control by direct PWM input
- Motor lock protection and built-in Auto-recovery Adjustable by a external capacitance
- Output pin for FG pulse (open drain)
- Output pin for lock detection (open drain)
- Various protection functions:
Under Voltage Lock Out (UVLO), Thermal protection
GND short protection, and Over Current Protection
- Package : SO type
14pin(0.65mm pitch)



DESCRIPTION

- AN44169A is a high efficiency single phase motor driver IC with built-in Soft Switching function for low noise operation. The soft switching period is automatically adjusted based on the motor current. This eliminates the need for individual adjustment of the soft switching period based on the Motor's specifications.
- With a wide input voltage range of 12V/24V, this IC is most suitable for usage in OA and FA equipment.

APPLICATIONS

- Fan motor

TYPICAL APPLICATION

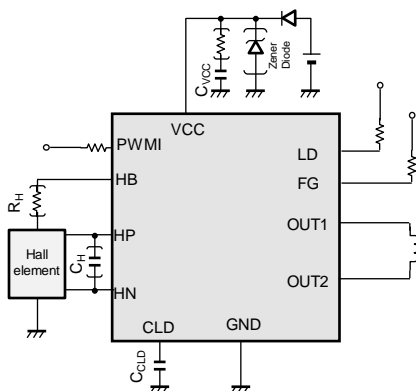

TYPICAL CHARACTERISTICS

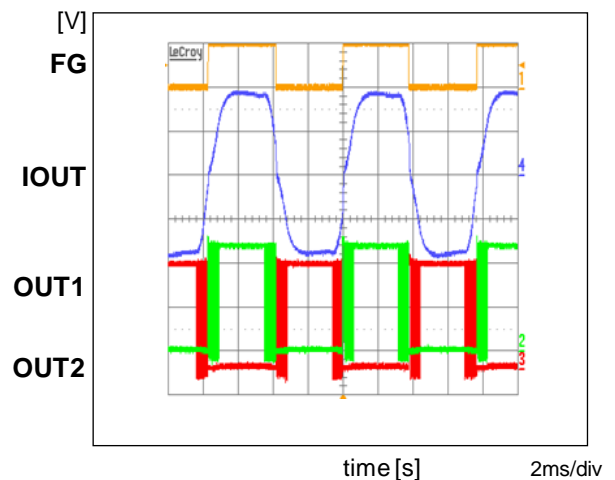

Condition:

$V_{CC} = 12\text{ V}$, PWMI = 100% duty , $C_{VCC} = 1\ \mu\text{F}$

Notes: The application circuit is an example. The operation of the mass production set is not guaranteed. Sufficient evaluation and verification is required in the design of the mass production set. The Customer is fully responsible for the incorporation of the above illustrated application circuit in the design of the equipment.

CONTENTS

■ FEATURES	1
■ DESCRIPTION	1
■ APPLICATIONS	1
■ TYPICAL APPLICATION	1
■ TYPICAL CHARACTERISTICS	1
■ CONTENTS	2
■ ABSOLUTE MAXIMUM RATINGS	3
■ POWER DISSIPATION RATING	3
■ RECOMMENDED OPERATING CONDITIONS	4
■ ELECTRICAL CHARACTERISTICS	5
■ PIN FUNCTIONS	7
■ PIN CONFIGURATION	7
■ FUNCTIONAL BLOCK DIAGRAM	8
■ OPERATION / Protection Function	9
■ OPERATION / Drive State Diagram	10
■ OPERATION / Functional explanation	11
■ AREA OF SAFE OPERATION	19
■ PIN EQUIVALENT CIRCUIT	20
■ APPLICATION INFORMATION	23
■ PACKAGE INFORMATION	27
■ IMPORTANT NOTICE	30

ABSOLUTE MAXIMUM RATINGS

Parameter	Symbol	Rating	Unit	Notes
Supply voltage	V_{CC}	-0.3 to +36	V	*1
Operating ambient temperature	T_{opr}	-40 to +90	°C	*2
Junction temperature	T_j	-40 to +150	°C	*2
Storage temperature	T_{stg}	-55 to +150	°C	*2
Input Voltage Range	V_{CLD}, V_{HP}, V_{HN}	-0.3 to +6	V	—
	V_{PWM}	-0.3 to +36	V	—
Output Voltage Range	V_{OUT1}, V_{OUT2}	-0.3 to +36	V	*1*3
	V_{FG}, V_{LD}	-0.3 to +36	V	—
	V_{HB}	-0.3 to +6	V	*3
Output Current Range	$I_{OUT1peak}, I_{OUT2peak}$	-1.4 to +1.4	A	*5
	I_{OUT1}, I_{OUT2}	-0.8 to +0.8	A	*6
	I_{FG}, I_{LD}	-5 to +10	mA	—
	I_{HB}	-10 to 0	mA	*4
ESD	HBM	2	kV	—
	MM	200	V	—

Notes: This product may sustain permanent damage if subjected to conditions higher than the above stated absolute maximum rating. This rating is the maximum rating and device operating at this range is not guaranteed as it is higher than our stated recommended operating range. When subjected under the absolute maximum rating for a long time, the reliability of the product may be affected.

*1: The values under the condition not exceeding the above absolute maximum ratings and the power dissipation.

*2: Except for the power dissipation, operating ambient temperature, and storage temperature, all ratings are for $T_a = 25^\circ\text{C}$.

*3: Applying external voltage into these pins is prohibited. Do not exceed the stated ratings even in transient state.

*4: Applying external current into these pins is prohibited. Do not exceed the stated ratings even in transient state.

*5: For $V_{CC} \geq 6\text{V}$, output current of $\pm 1.4\text{A}$ is only allowed within 1s.

*6: Applying external current into these pins is prohibited, the maximum value in the case of satisfying the rated power consumption and other rating items. However, I except the * 1 conditions.

POWER DISSIPATION RATING

Package	θ_{ja}	P_D ($T_a=25^\circ\text{C}$)	P_D ($T_a=90^\circ\text{C}$)
14 pin Plastic TSSOP Package (0.65mm Pitch)	157.7°C/W	792.8mW	380.5mW

Notes: For the actual usage, please refer to the P_D - T_a characteristics diagram in the package specification, follow the power supply voltage, load and ambient temperature conditions to ensure that there is enough margin and the thermal design does not exceed the allowable value.

*1: Glass-Epoxy Substrate (1 Layers) [70 × 70 × 1.6 t](mm)



CAUTION

Although this IC has built-in ESD protection circuit, it may still sustain permanent damage if not handled properly. Therefore, proper ESD precautions are recommended to avoid electrostatic damage to the MOS gates.

RECOMMENDED OPERATING CONDITIONS

Parameter	Symbol	Min.	Typ.	Max.	Unit	Notes
Supply voltage range	V_{CC}	5.0	—	28	V	*1
Input voltage range	V_{HP}	0	—	1.5	V	*2
	V_{HN}	0	—	1.5	V	*2
	V_{PWM}	0	—	28	V	*2
External constants	C_{VCC}	—	1	—	μF	*3
	C_{CLD}	—	330	—	pF	*3

Notes *1: It is a value under the conditions which do not exceed the absolute maximum rating and the power dissipation.

*2: For setting range of input control voltage, refer to Electrical Characteristics and Operation.

*3: Operation of mass production set is not guaranteed. Perform enough evaluation and verification on the design of mass production set. If the VCC terminal voltage is raised by the regenerative current, at the time of start-up or stop operating Please connect a zener diode between VCC – GND terminal.

ELECTRICAL CHARACTERISTICS

 $V_{CC} = 12.0\text{ V}, 24.0\text{ V}$

 Note: $T_a = 25^\circ\text{C} \pm 2^\circ\text{C}$ unless otherwise noted.

Parameter	Symbol	Condition	Limits			Unit	Note
			Min	Typ	Max		
Circuit Current							
V_{CC} current 1	I_{CC1}	Output OPEN, Lock State	—	1.5	3	mA	—
V_{CC} current 2	I_{CC2}	Output OPEN, 50% duty	—	2.0	4	mA	—
FG Block							
Low-level output voltage	V_{OLFG}	$I_O = 5\text{ mA}$	—	0.1	0.3	V	—
Output leak current	I_{LFG}	$V_O = 28\text{ V}$	—	—	30	μA	—
LD Block							
Low-level output voltage	V_{OLD}	$I_O = 5\text{ mA}$	—	0.1	0.3	V	—
Output leak current	I_{LLD}	$V_O = 28\text{ V}$	—	—	30	μA	—
Power Block							
On resistance (High Side + Low Side)	R_{ONHL}	$I = 200\text{ mA}$	—	1.6	2.25	Ω	—
Diode forward voltage	V_{DI}	$I = 200\text{ mA}$	0.6	0.8	1	V	—
Hall Block							
Input dynamic range	V_{HA}	—	0	—	1.5	V	—
Pin input current	I_{HA}	—	-2	0	2	μA	—
Minimum input voltage amplitude	V_{HA}	—	25	—	—	mV	—
Hysteresis width	V_{HHYS}	—	—	10	20	mV	—
Hall Bias							
Output Voltage	V_{HB}	$I_O = -2\text{ mA}$	1.05	1.2	1.35	V	—
PWM Input							
Stop control input	V_{PWMIN}		2	4	6	%	—
Maximum speed input	V_{PWMMAX}		—	100	—	%	—
Low-level input voltage	V_{PWML}		—	—	0.55	V	—
High-level input voltage	V_{PVMH}		2.0	—	—	V	—
Low-level input current	I_{PVMINL}	$V_i = 0\text{ V}$	-39	-26	-13	μA	—
High-level input current	I_{PVMINH}	$V_i = 3.3\text{ V}$	5.5	11	16.5	μA	—
Input current at max. V_{CC}	$I_{PVMINHH}$	$V_i = 35\text{ V}$	480	686	892	μA	—
Input frequency range	F_{PWM}	—	15	—	50	kHz	—

Notes : *1 : These are values checked by design but not production tested.

*2 : Typical Design Value.

ELECTRICAL CHARACTERISTICS (continued)

 $V_{CC} = 12.0\text{ V}, 24.0\text{ V}$

 Note: $T_a = 25^\circ\text{C} \pm 2^\circ\text{C}$ unless otherwise noted.

Parameter	Symbol	Condition	Limits			Unit	Note
			Min	Typ	Max		
Motor Lock Protection							
Lock protection time setting for reference clock frequency	F_{LOCK}	$C_{\text{CLD}}=330\text{pF}$	7.6	10.2	12.8	kHz	—
Lock detection time	t_{LOCK1}	$C_{\text{CLD}}=330\text{pF}$	—	0.48	—	s	*2
Lock release time	t_{LOCK2}	$C_{\text{CLD}}=330\text{pF}$	—	4.8	—	s	*2
Lock protection ratio	LD_{RATIO}	—	—	10	—	—	*2
Thermal Protection							
Protection operating temperature	TSD_{ON}	—	—	160	—	$^\circ\text{C}$	*2
Hysteresis width	TSD_{HYS}	—	—	25	—	$^\circ\text{C}$	*2
Under Voltage Lock Out							
Protection operating voltage	V_{LVON}	—	—	3.5	—	V	*2
Hysteresis width	V_{LVOHYS}	—	—	0.2	—	V	*2
Overcurrent Protection							
Output limit Current	I_{OCL}	Normal operation with Motor	1.0	1.2	1.4	A	—

Notes : *1 : These are values checked by design but not production tested.

*2 : Typical Design Value.

PIN CONFIGURATION

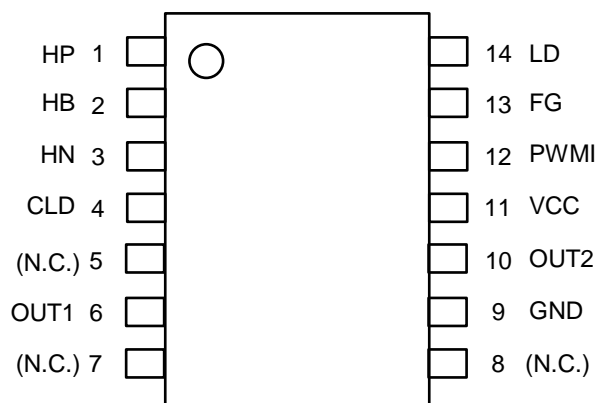

PIN FUNCTIONS

Pin No.	Pin name	Type	Description
1	HP	Input	Hall amplifier input (+)
2	HB	Output	Hall bias output
3	HN	Input	Hall amplifier input (-)
4	CLD	Input	Capacitor connection pin for reference clock
5	(N.C.)	—	Non connection
6	OUT1	Output	Channel 1 output
7	(N.C.)	—	Non connection
8	(N.C.)	—	Non connection
9	GND	Ground	Ground
10	OUT2	Output	Channel 2 output
11	VCC	Power	Supply voltage for internal circuit
12	PWMI	Input	Voltage input for setting rotating speed
13	FG	Output	FG external output
14	LD	Output	LD external output

BLOCK DIAGRAM

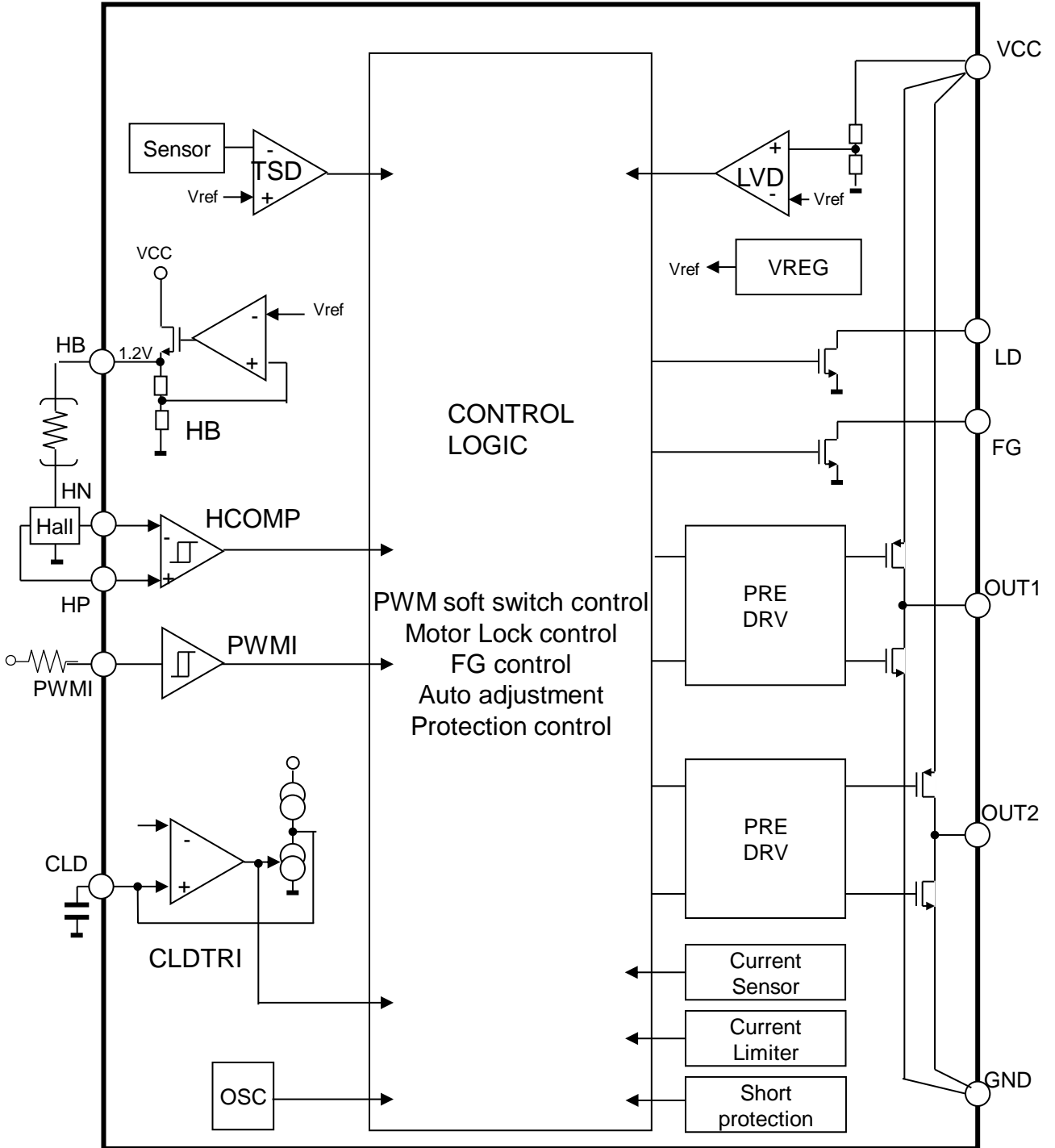

OPERATION

■ Protection Function

Note) The characteristics listed below are reference values derived from design of the IC and are not guaranteed.

Function name	Operate	Release	Note
TSD	160°C	135°C	Low side power-Tr are OFF while protection function works.
Current limit	1.2A	After fixed time progress	If motor current reaches 1.2A, output current will be restricted in turning off an output for a fixed time. ON time , and OFF time are such as below. ON : 2μsec, OFF : 10.0μsec (in start up period ON:1.5μsec, OFF:40μsec)
UVLO (VCC)	3.5V	3.7V	It is protection of the low-voltage condition of the power supply voltage. If protected operation is carried out, high side output are switching according HALL input, and low side output power is turned off.
Motor locked protection	When FG pulse does not change within a set time. (latch protection)	<ul style="list-style-type: none"> • at UVLO • After fixed time progress • at PWMI stop control 	UVLO and PWMI stop control release protection and a count are reset. A protection setting time is determined by the external capacitance connected to the CLD pin. (Time(s) = External Cap(pF) × 0.00145) Restart after this time × 10
Short protection of Motor output - VCC	Current limiting	After fixed time progress	Protection by output current limiting
Short protection of Motor output - GND	latch protection by constant time detection.	• at UVLO	Latch protection is carried out. Release is performed by UVLO.

Note : These are values checked by design but not production tested.

OPERATION (continued)

■ Drive State Diagram (Soft Switching)

Soft switching section counts the period of the FG signal, a half cycle of the FG signal as an electrical angle 180deg, is set to a fixed electric angle 22.5deg. (Rising = falling = 22.5deg)

Note) The characteristics listed below are reference values derived from design of the IC and are not guaranteed.

without PWM control

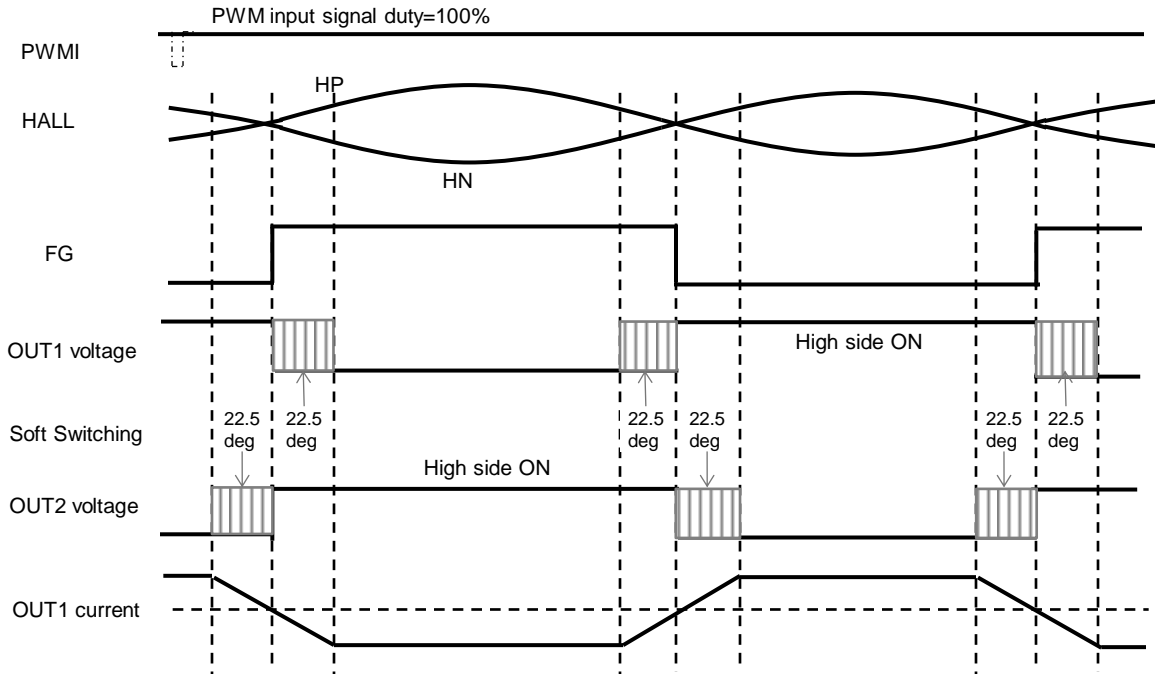

with PWM control

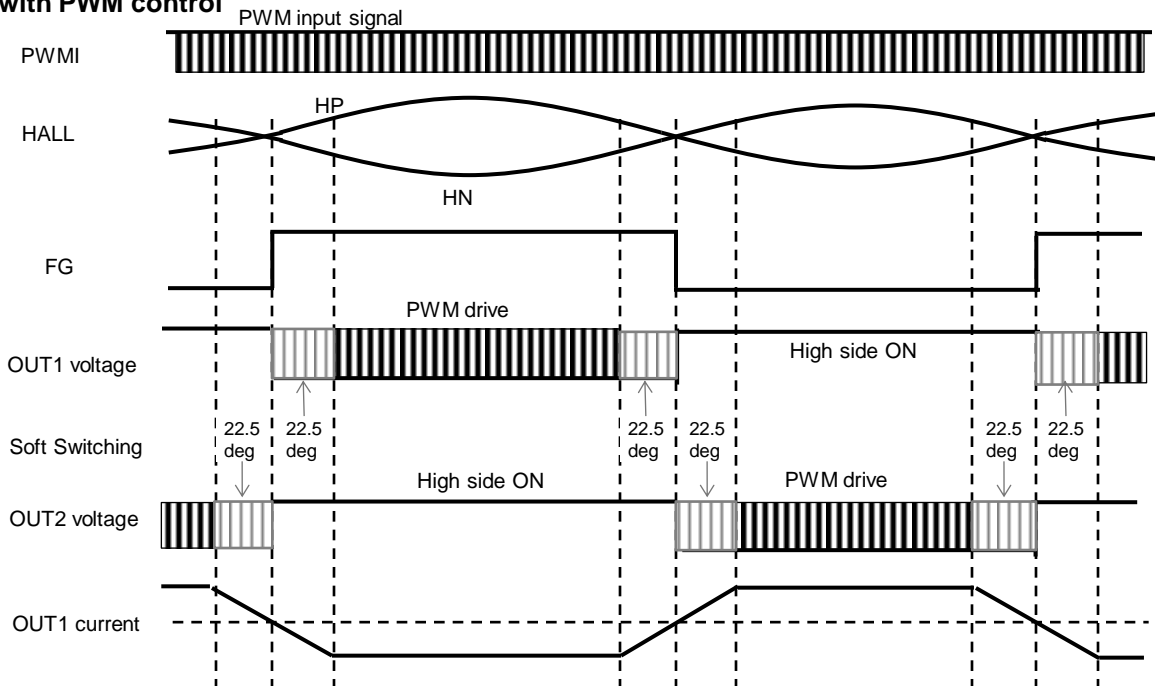

OPERATION (continued)

■ Functional explanation

Note) The characteristics listed below are reference values derived from design of the IC and are not guaranteed.

1. Start up (In the case without PWM control)

Start up..... After applying the VCC of power supply within the operation limits, IC becomes start mode as normal startup mode, when you open the PWMI terminal, In startup, it will start on the PWM operation at a fixed duty (duty=50%, f=40kHz). After HALL input is switched two periods, it becomes normal driving of duty = 100%.

Soft switching...HALL comparator detects the switching of the HALL, OUT1 and OUT2 operates soft switching in the phase angle period of 22.5 degree and 40kHz. And this function make the fluctuation of the driving current smoothly.

【 Start up with HP < HN】

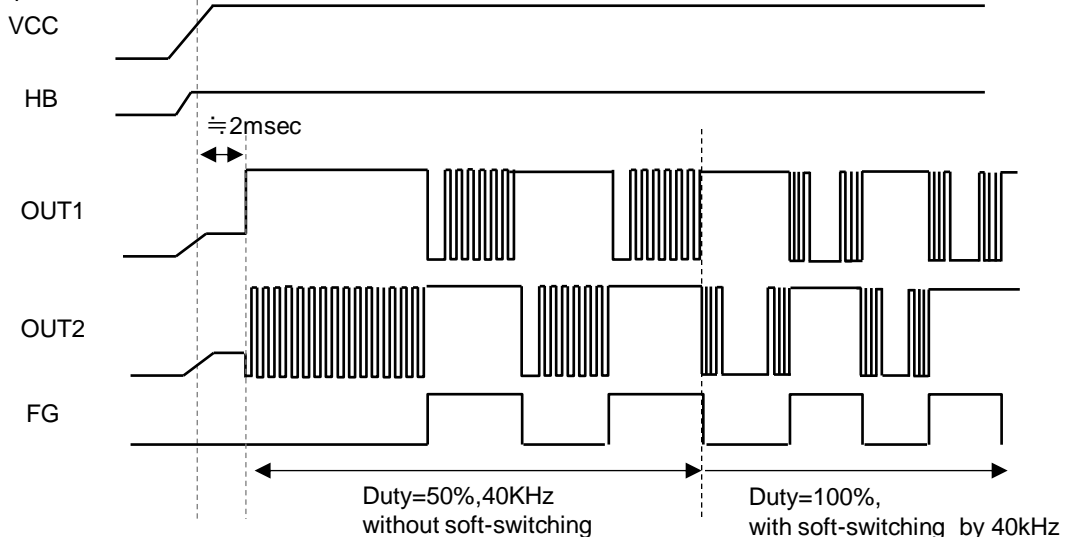

【Start up with HP > HN】

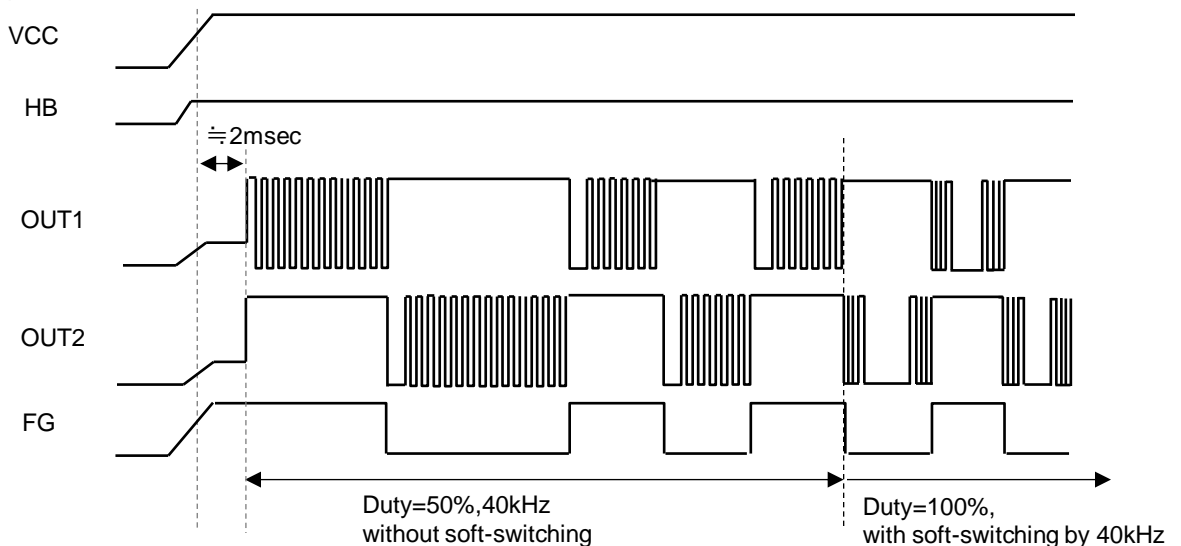

It starts without software SW, fixed duty=50%.

By detecting the Hall two periods, operates to set duty=100% & software switching

OPERATION (continued)

■ Functional explanation (continued)

Note) The characteristics listed below are reference values derived from design of the IC and are not guaranteed.

2. Start up (In the case with PWM control)

Start up After applying the VCC of power supply within the operation limits,
IC becomes start mode by duty=50% PWM operation in the two period of HALL.
When PWM signal are input from PWMI terminal, and drive in PWM mode after the above two periods.

Soft-switching Soft switching operates at the frequency of the PWM input signal, soft switching operation.

【 Start up with HP<HN】

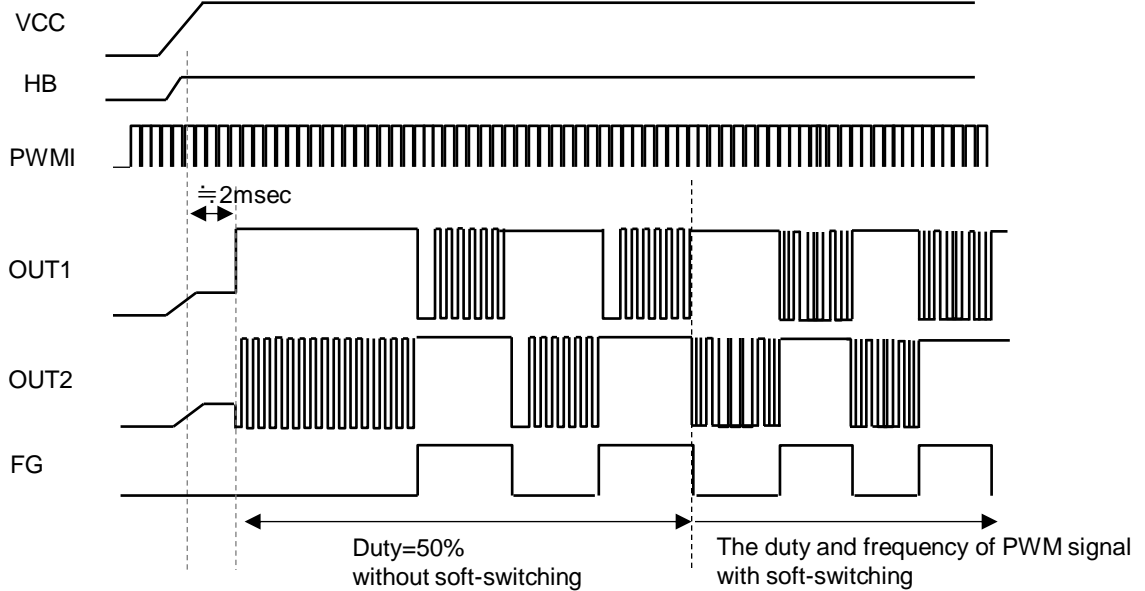

【 Start up with HP>HN】

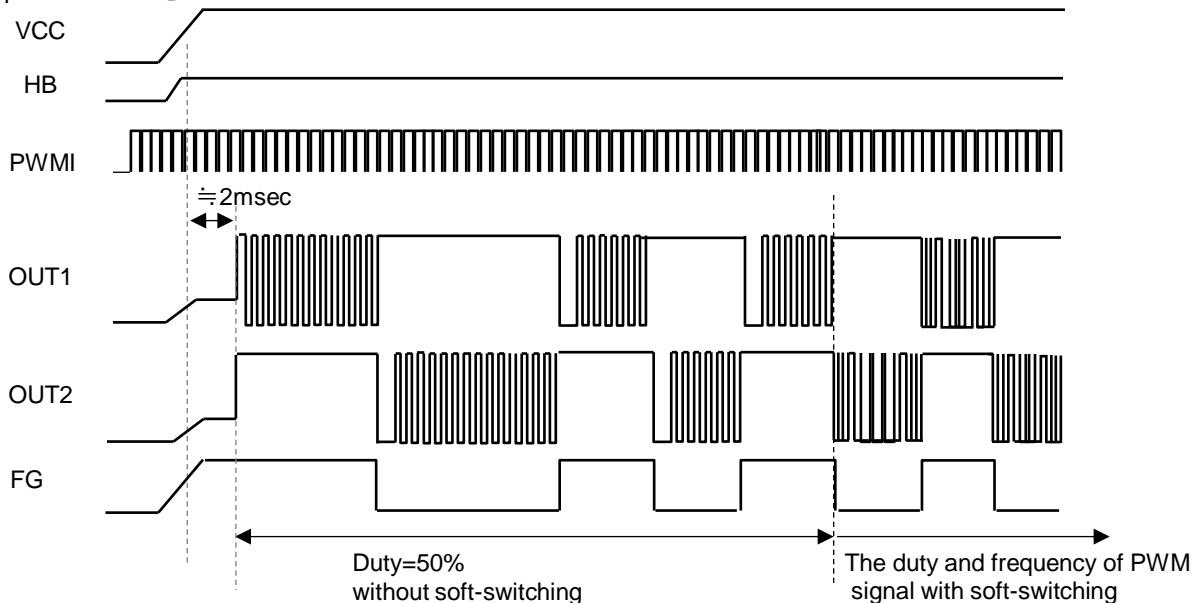

It starts without software SW, fixed duty=50%.

By detecting the Hall two periods, operates to set PWMI duty & software switching

OPERATION (continued)

■ Functional explanation (continued)

Note) The characteristics listed below are reference values derived from design of the IC and are not guaranteed.

3. Speed control

-PWM signal input

By inputting a PWM signal to PWMI pin and controlling its duty, it controls the output.

PWMI pin:

H level voltage input → PWM phase (Low side) output ON

L level voltage input → PWM phase (Low side) output OFF

Drive mode	PWM system	PWM generation	Summary block diagram
PWM mode	PWM through	PWMIN = PWM OUT	

The frequency range which can be input to IC is from 15kHz to 50kHz.

If the PWM frequency which is input to IC is over the setting range, the built-in frequency limit circuit operates and The control circuit operates on the following states.

- 1) If the PWM frequency is higher than the setting range. (PWM frequency > 200kHz (typical value))
The both the PWM frequency and the PWM duty are latched and IC continues the operation.
- 2) If the PWM frequency is lower than the setting range. (PWM frequency < 10kHz (typical value))
The PWM frequency is latched only.
The PWM duty rises with decreasing the frequency and IC finally continues the operation on 100% duty.

OPERATION (continued)

■ Functional explanation (continued)

Note) The characteristics listed below are reference values derived from design of the IC and are not guaranteed.

4. Motor locked protection circuit

When FG non-signal state continues for a certain period of time in the motor normal operation mode, locked protection circuit operates.

In the locked protection mode, low side power outputs are OFF state.

The value of the locked protection time can be calculated by the following equation approximately.

$$\text{Restricted protection setting time (sec)} \approx \text{Capacitance value of CLD (pF)} \times 0.00145$$

If you connect capacitance of 330pF in CLD pin, the restricted protection time is about 0.48s.

Make setting with a margin for motor start-up time.

Conditions to release the motor restricted protection, and to reset the counter are as follows.

- In detecting UVLO mode
- After fixed time progress (Restricted protection setting time x 10 (sec), : about 4.8 sec / $C_{CLD}=330\text{pF}$)
- at inputting PWMI stop control

If you do not use the locked protection, connect the CLD pin to the GND.

•Restricted protection explanation

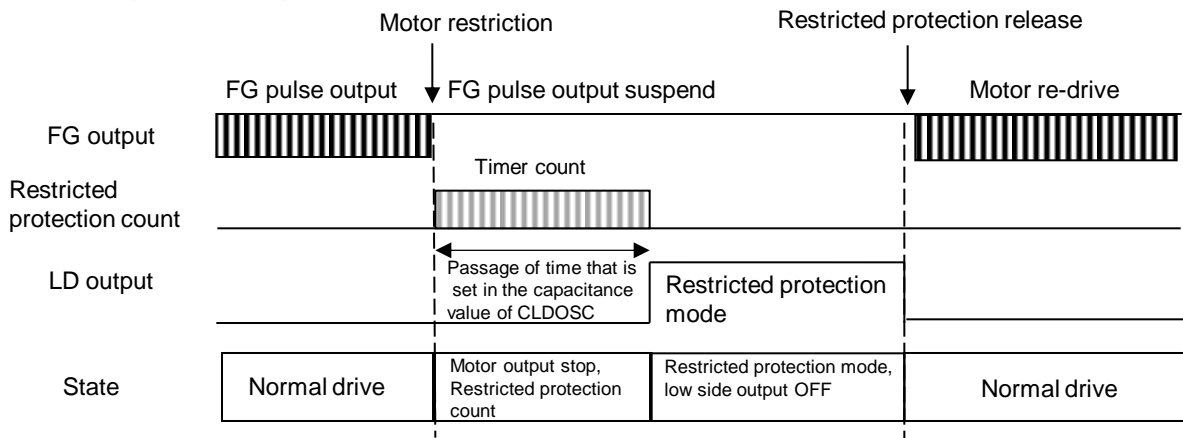

OPERATION (continued)

■ Functional explanation (continued)

Note) The characteristics listed below are reference values derived from design of the IC and are not guaranteed.

5. Low voltage protection

This IC monitors the voltage VCC. If VCC voltage becomes 3.5V or less, low-voltage protection is activated. In the low voltage protection operation, the output of each phase is high side on, low side off.

In addition, if the VCC voltage drops further, the internal circuit is no longer working properly, the outputs, all phases are HiZ (all phases OFF).

Hysteresis of 0.2V is set in the VCC low voltage protection function. If the VCC is restored to 3.7V from protection mode, the low voltage protection is released.

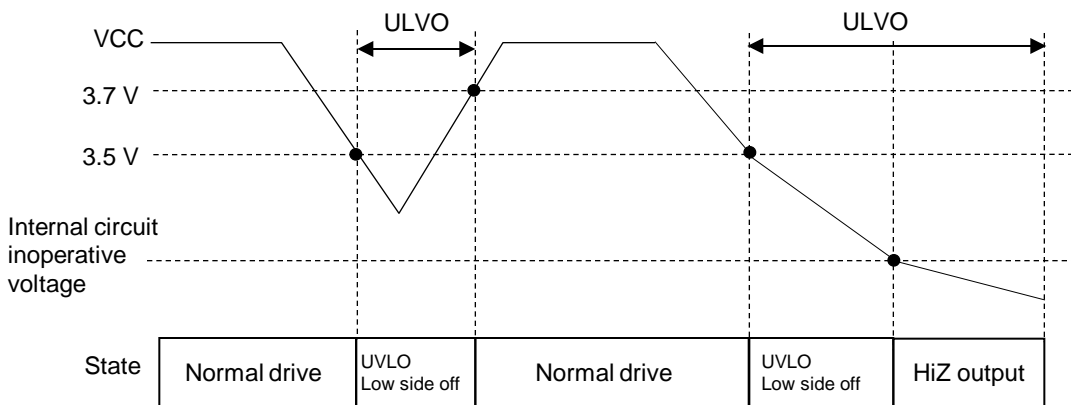

6. Thermal protection (TSD)

If an IC junction temperature is 160°C (design target value) or more, the thermal protection is activated, and the motor outputs becomes low side off .

If the IC junction temperature is 135°C (design target value) or less, the protection is released.

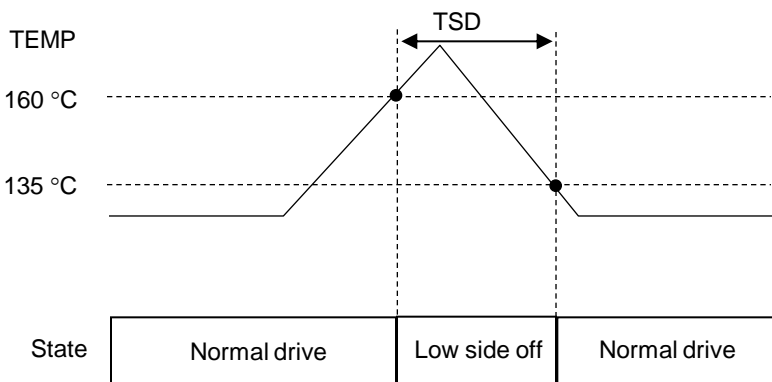

OPERATION (continued)

■ Functional explanation (continued)

Note) The characteristics listed below are reference values derived from design of the IC and are not guaranteed.

7. Overcurrent protection (PWMIN mode)

Here, describes the overcurrent protection.

It detects an overcurrent at 1.2A, as overcurrent does not flow at OUT1, OUT2

After detecting a current greater than the setting value, by shutting off the output transistor during the predetermined time, it protects an over-current.

On time 2 μsec (in start up period 1.5 μsec)

Off time 10 μsec (in start up period 40 μsec)

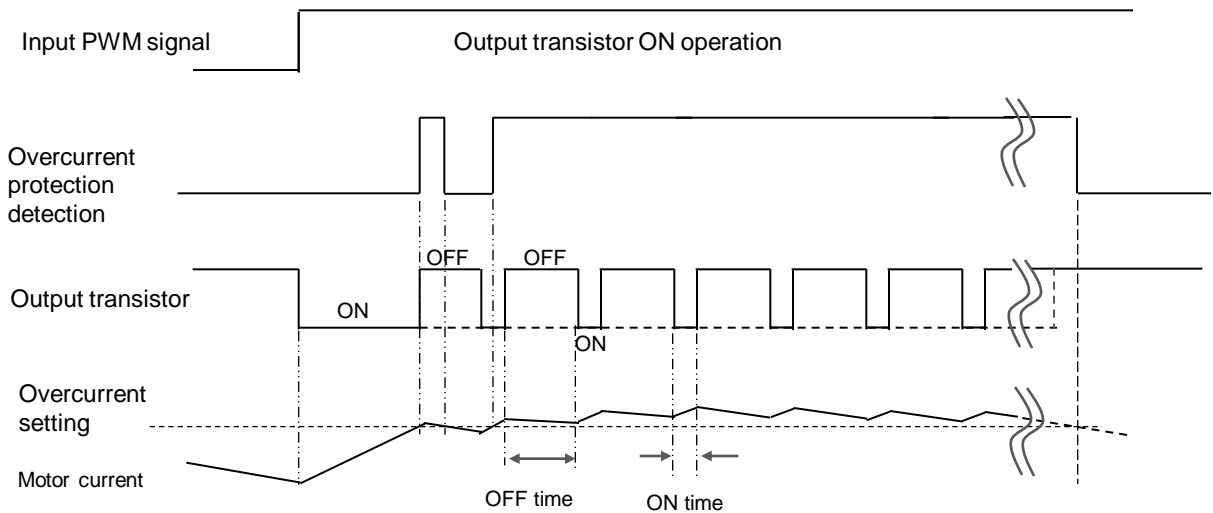

OPERATION (continued)

■ Functional explanation (continued)

Note) The characteristics listed below are reference values derived from design of the IC and are not guaranteed.

8. Hall input

Hall hysteresis comparator carries out position detection. If the amplitude of the sine wave is small, the phase delay of the comparator output becomes significant, therefore, increase the amplitude. Recommendation is 200 mV or more. Also, if the hole chattering occurs, put capacitor between HP (1 pin) and HN (3 pin).

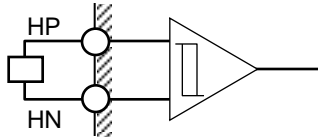

The following is a schematic diagram of the characteristics.

J-1 hysteresis level: 5 mV L → H

J-2 hysteresis level: 5 mV H → L

J-3 hysteresis width: 10 mV (typ)

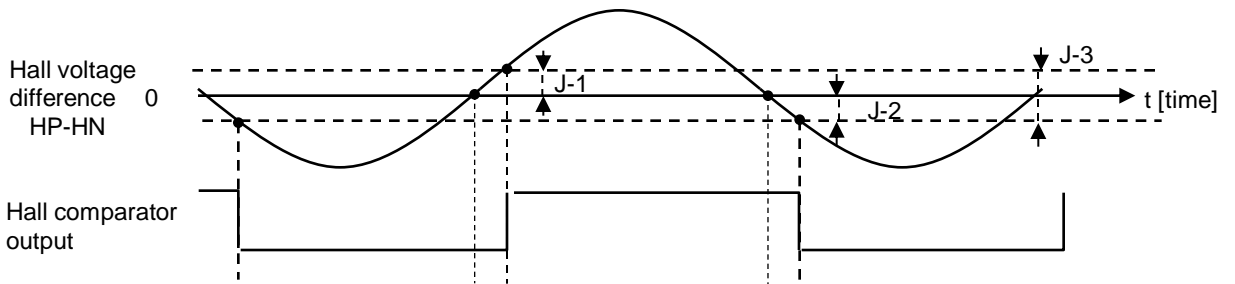

• Relationship between Hall voltage and FG

For the one cycle sine wave of Hall, it outputs FG pulse one cycle.

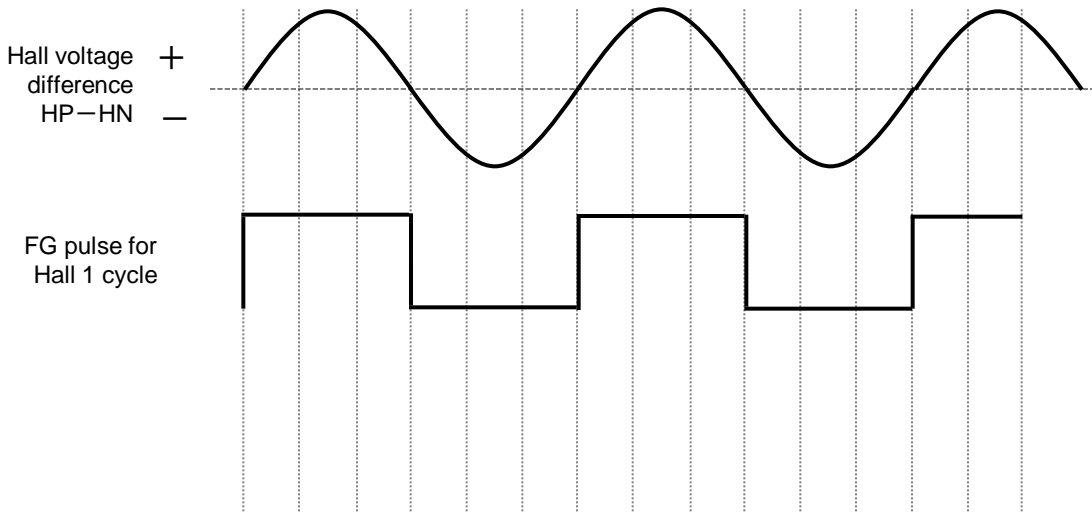

OPERATION (continued)**■ Functional explanation (continued)**

Note) The characteristics listed below are reference values derived from design of the IC and are not guaranteed.

9. CLD pin

CLD pin is the terminal that generates a clock for lock protection.

By varying the capacitor connected to this terminal, to set the protection time.

When you use 330pF, it is detected by 0.48sec, and restart after stopping during 4.8sec.

10. LD pin

LD pin outputs the judgment of lock protection.

Since it is an open-drain output, please connect a pull-up resistor to the power supply, when you use this function.

In the normal operation, LD outputs low during detection, and LD outputs high during protection.

11. FG pin

FG pin outputs a switching of HALL signal.

Since it is an open-drain output, please connect a pull-up resistor to the power supply, when you use this function.

FG outputs high, when HP voltage > HN voltage.

12. PWMI pin

PWMI pin is a terminal for inputting a PWM signal.

PWMI = H, PWM drive output of OUT1,OUT2 are on (on-duty).

PWMI = L, PWM drive output of OUT1,OUT2 are off (off-duty).

When you open PWMI terminal, it is biased about 1.9V by the internal circuit, and it outputs as 100% duty for the motor drive.

13. HB pin

HB pin is a terminal for supplying the bias voltage to the hall element.

1.2V is outputted from HB terminal.

If it is necessary to take countermeasures to prevent the noise, please add the hall capacitance between HB terminal and GND terminal.

The maximum value of the hall capacitance is 0.1μF.

It has the effect of suppressing the heat generation of the IC by adding a series resistor to the Hall element. However, Hall amplitude should be setting the resistance constant perform sufficient evaluation because it becomes smaller in proportion.

AREA OF SAFE OPERATION

Note) The characteristics listed below are reference values derived from design of the IC and are not guaranteed.

This data is a single pulse data under $T_a = 25\text{ }^\circ\text{C}$.
Under the actual usage, there could be T_j rising and more than one pulse applied.
Therefore, please use this data only as a reference.
Customer shall conduct sufficient reliability evaluation and verification on the set.

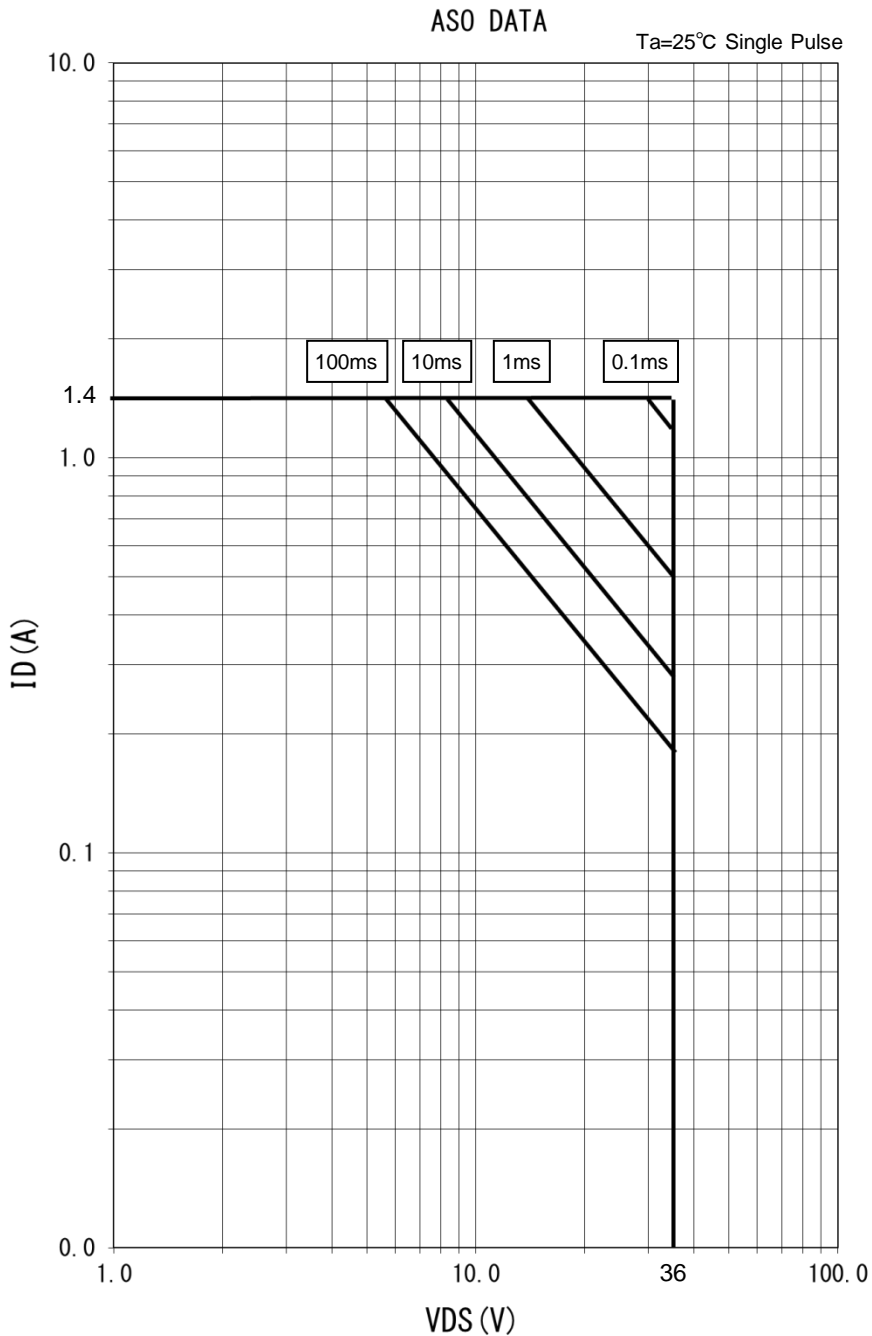

PIN EQUIVALENT CIRCUIT

Note: The characteristics listed below are reference values derived from the design of the IC and are not guaranteed.

Pin No.	Internal circuit	Impedance	Description
1, 3		—	<p>Pin1(HP) :Hall amplifier + input pin</p> <p>Pin3(HN) :Hall amplifier – input pin</p>
2		120kΩ	<p>Pin2(HB) :Hall bias 1.2V output pin</p>

PIN EQUIVALENT CIRCUIT (continued)

Note: The characteristics listed below are reference values derived from the design of the IC and are not guaranteed.

Pin No.	Internal circuit	Impedance	Description
4		—	<p>Pin4(CLD) :Connect a capacitor to set oscillation frequency of motor restricted protection pin</p>
6, 10		—	<p>Pin6(OUT1), Pin10(OUT2) :Motor drive output pin</p>

PIN EQUIVALENT CIRCUIT (continued)

Note: The characteristics listed below are reference values derived from the design of the IC and are not guaranteed.

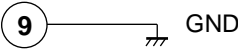
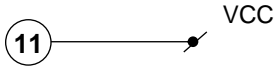
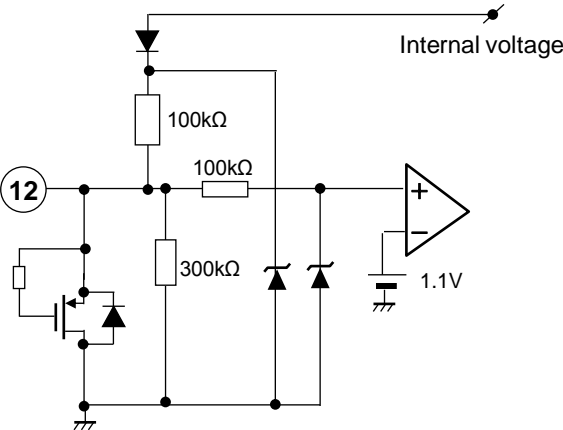
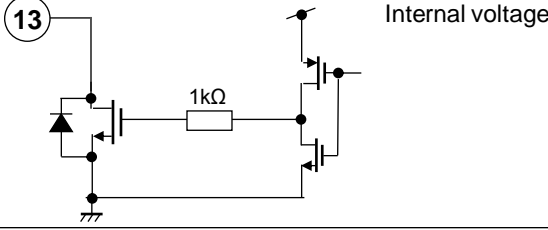
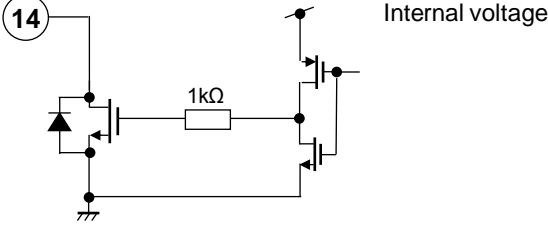
Pin No.	Internal circuit	Impedance	Description
9		—	Pin9(GND) :GND pin
11		—	Pin11(VCC) :Power supply pin
12		—	Pin12(PWMI) :PWM signal input pin, High period is on, Low period is off
13		—	Pin13(FG) :FG signal output pin
14		—	Pin14(LD) :Motor lock protection signal output pin

APPLICATION INFORMATION

1. Precaution at restarting under decelerating.

When IC turns on, The duty of PWM pulse is forced 50% without Auto Phase Shift and Soft Switch until second FG pulse. So, in case of restarting under condition which motor is decelerating. Because the possibility which the motor current is switched before the motor current becomes to zero is high, the motor current flows into VCC. So VCC rises higher than setting voltage, there is possibility that VCC voltage is over IC's absolute maximum voltage. If this situation happens, IC destroys at worst.

Please countermeasure to cramp VCC voltage by adding the zener diode in parallel with bypass capacitance and ensure sufficient evaluation is performed to verify that there is no problem.

2. Precaution at turn off VCC

When the power supply voltage is turned off under high speed rotation. Because the motor's BEMF voltage is high, VCC is supplied by BEMF voltage, and IC repeats start and stop.

The possibility which the motor current flows into VCC is high, VCC rises higher than setting voltage, there is possibility that VCC voltage is over IC's absolute maximum voltage.

Please countermeasure to cramp VCC voltage by adding the zener diode in parallel with bypass capacitance and ensure sufficient evaluation is performed to verify that there is no problem.

If the reverse current to VCC, including of above 1 or 2, occurs and the countermeasure is needed, please countermeasure to cramp VCC voltage by adding the zener diode in parallel with bypass capacitance and ensure sufficient evaluation is performed to verify that there is no problem.

(Countermeasure Circuit)

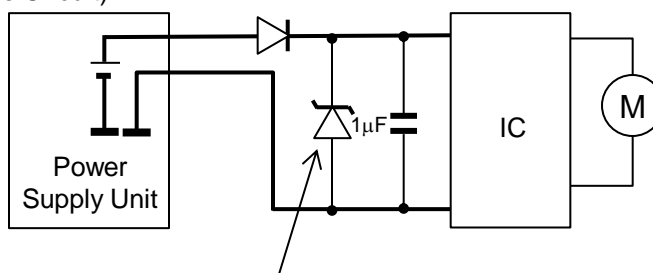

Add the zener diode in parallel with bypass capacitance

APPLICATION INFORMATION (continued)

3.Precaution at PWM Motion

When VCC and GND wire is long, There is possibility which current peak of motor input current is caused at PWM motion due to wire's parasitic inductance.

Please countermeasure to reduce current peak of motor input current by adding a resistance in series with bypass capacitance and ensure sufficient evaluation is performed to verify that there is no problem.

(Circuit)

The current peak is caused at PWM motion due to the wire's parasitic inductance.

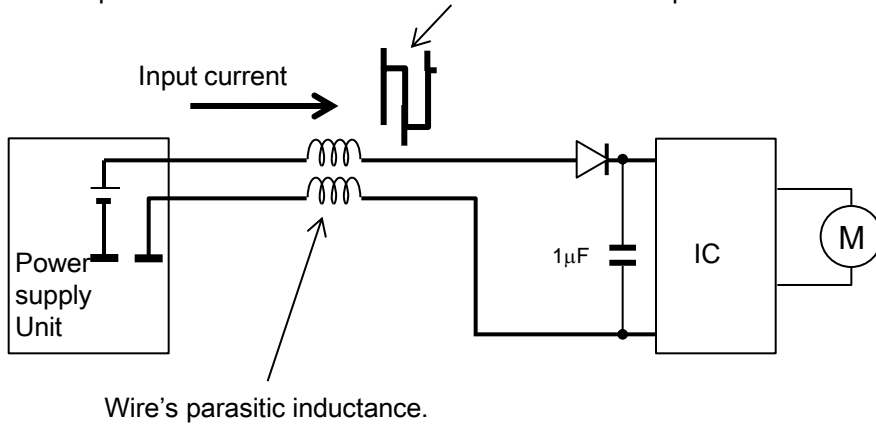

(Countermeasure Circuit)

The current peak is reduces according to adding in series with bypass capacitance.

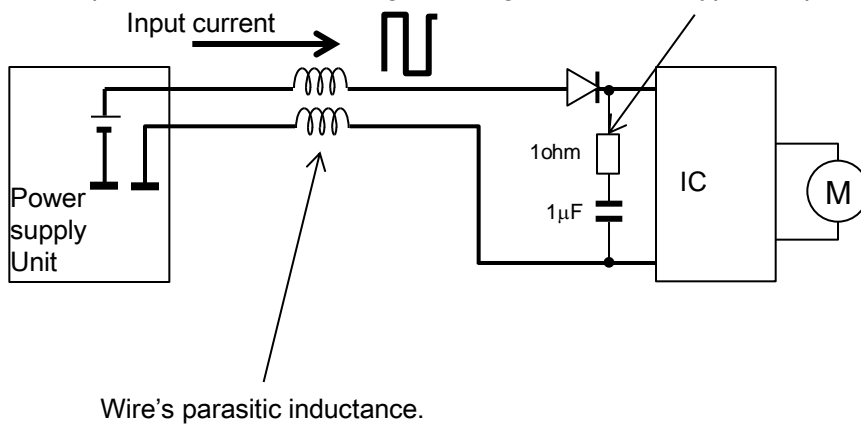

APPLICATION INFORMATION (continued)

4. Precaution at inputting power to VCC

When the IC is powered on, it is recommended that VCC voltage rises slower than $0.24\text{V}/\mu\text{s}$, also when IC is shut down, it is recommended that VCC voltage falls higher than $-0.24\text{V}/\mu\text{s}$. When power up is performed at high-speed, rush current must flow into bypass capacitance between VCC and GND. So VCC rises higher than setting voltage due to wire's parasitic inductance, there is possibility that VCC voltage is over IC's absolute maximum voltage.

please countermeasure to reduce rush current by adding a resistance in series with bypass capacitance and ensure sufficient evaluation is performed to verify that there is no problem.

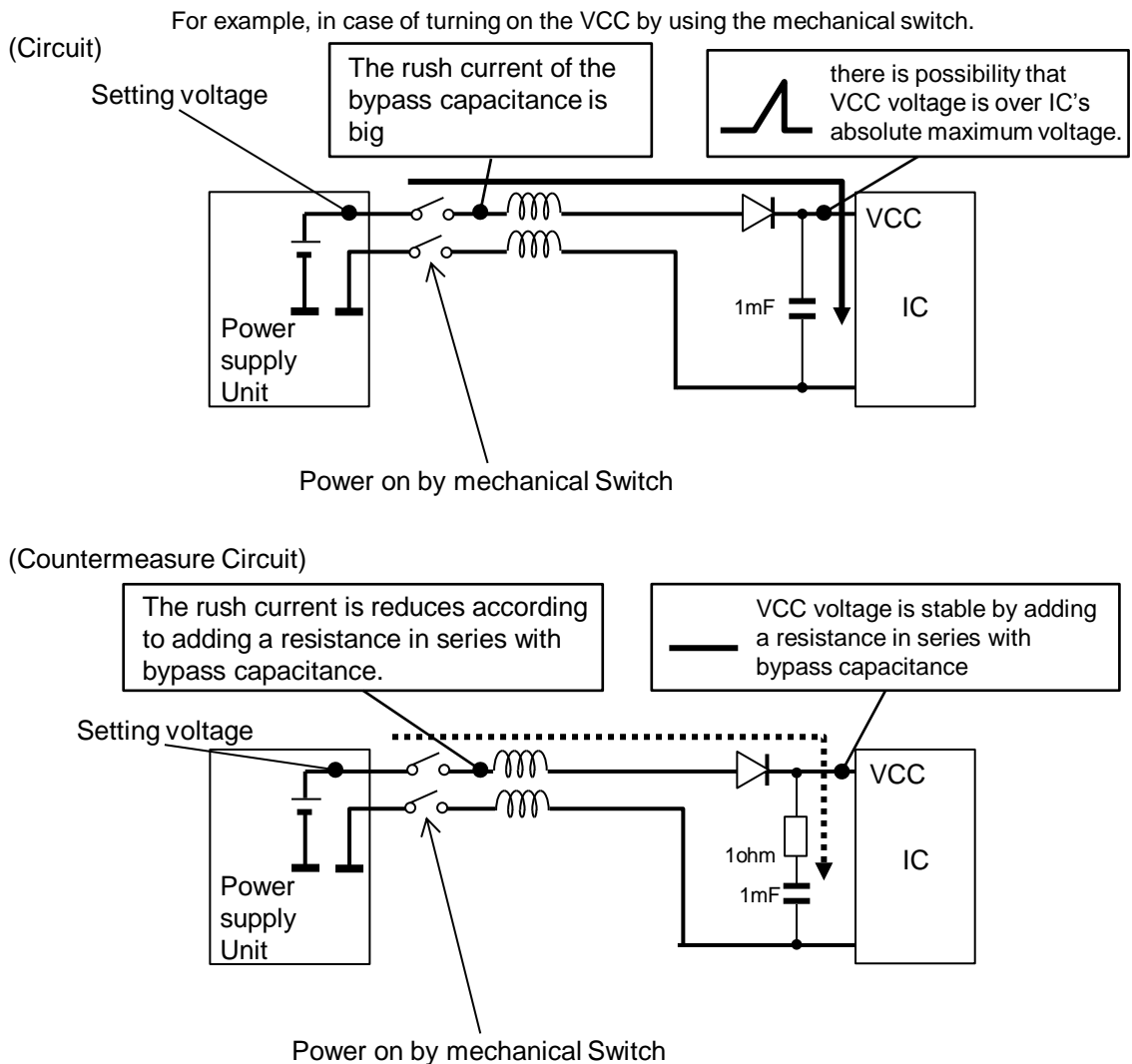

APPLICATION INFORMATION (continued)

5. Recommended position for hall element

This driver detects the ineffective current during phase switching and this driver has automatic phase adjustment for optimized motor current.

We recommend that you set the hall element in the position shown in the following figure1.

If you set the hall element in the position shown in the following figure2, it may not be started the motor and it may be that automatic phase adjustment is low performance.

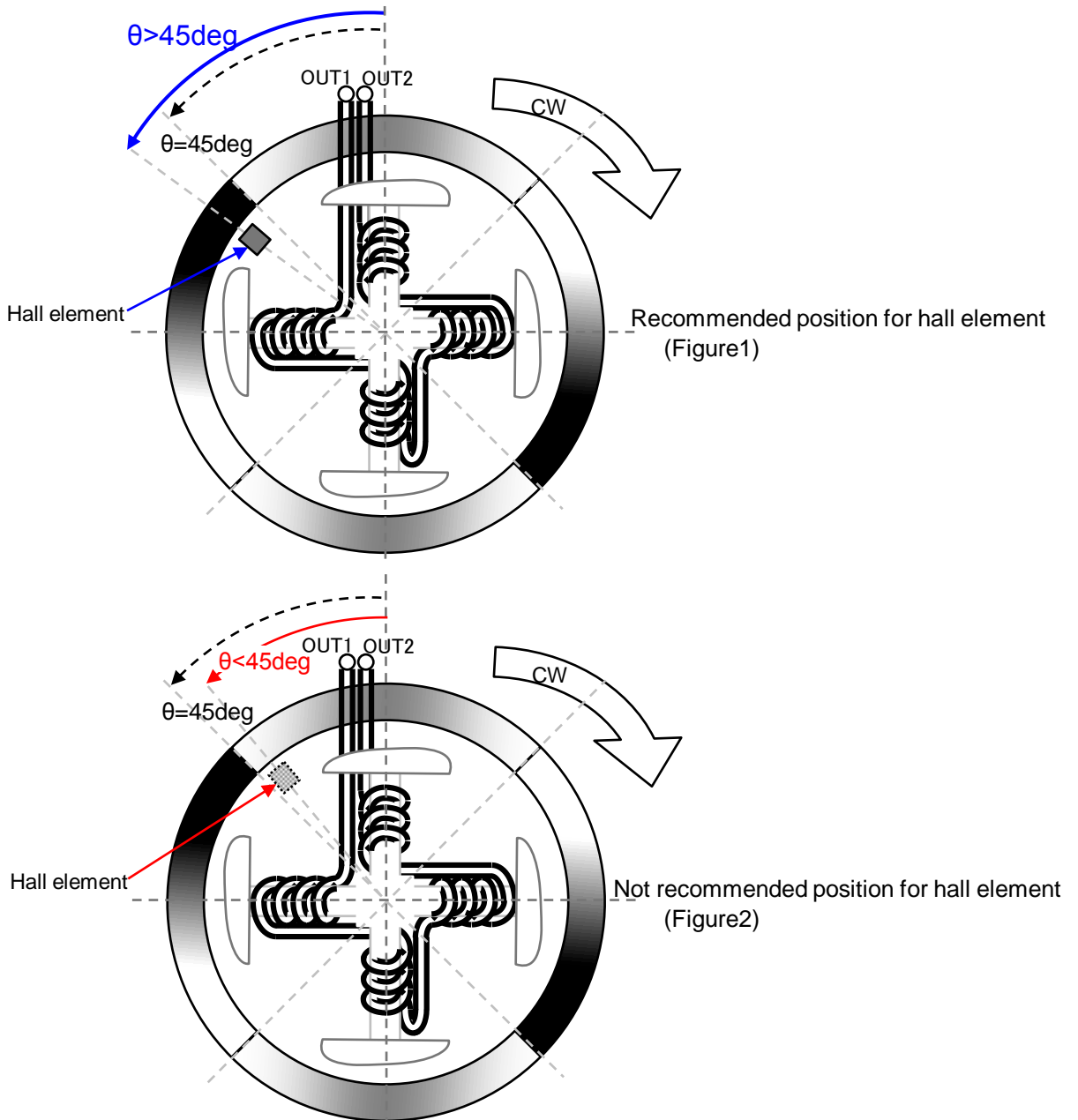

PACKAGE INFORMATION

Package code : MSOP014-P-0225XZL (TSSOP14)

Unit : mm

Outline Drawing

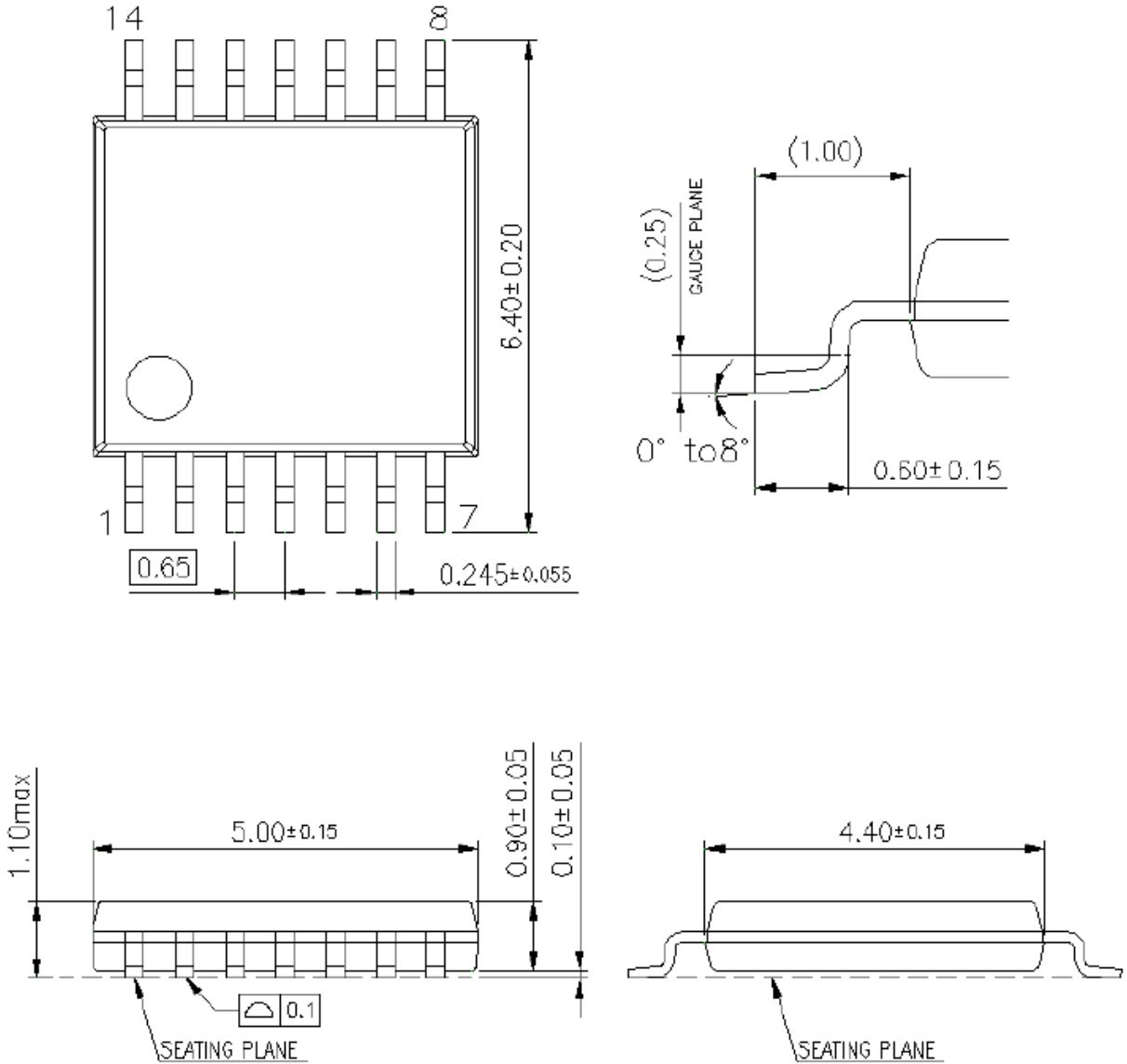

Body Material : Br/Sb Free Epoxy Resin
Lead Material : Cu Alloy
Lead Finish Method : Pd Plating

PACKAGE INFORMATION (Continued)
Power Dissipation (Technical Report)

Package code : MSOP014-P-0225XZL (TSSOP14)

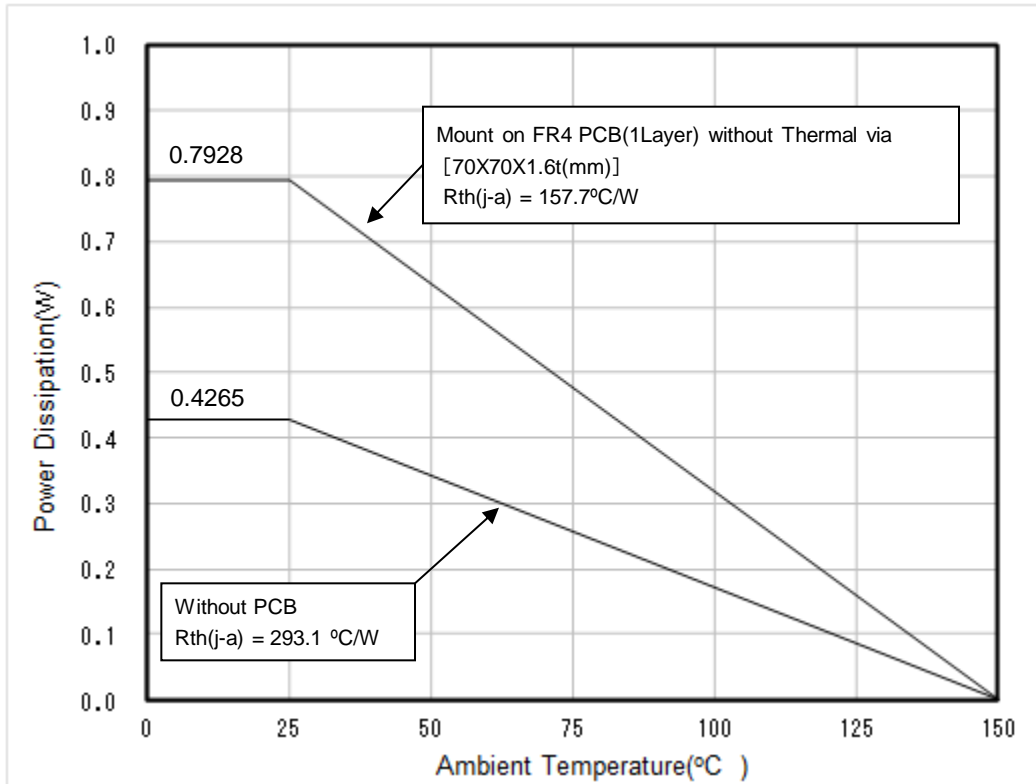

PACKAGE INFORMATION (Continued)

Power Dissipation (Supplementary Explanation)

[Experiment environment]

Power Dissipation (Technical Report) is a result in the experiment environment of SEMI standard conformity. (Ambient air temperature (Ta) is 25 degrees C)

[Supplementary information of PWB to be used for measurement]

The supplement of PWB information for Power Dissipation data (Technical Report) are shown below.

Indication	Total Layer	Resin Material
Phenolic cellulose paper	1-layer	FR-1
Glass-Epoxy	1-layer	FR-4
Glass-Epoxy 2layer	2-layer	FR-4

[Notes about Power Dissipation (Thermal Resistance)]

Power Dissipation value (Thermal Resistance) depend on the conditions of the surroundings, such as specification of PWB, mounting condition and ambient temperature. (Power Dissipation (Thermal Resistance) is not a fixed value.)

The Power Dissipation value (Technical Report) is the result based on evaluation under specified conditions (Evaluation environment under SEMI International Standards). Power Dissipation value (Thermal resistance) depends and changes with the environmental conditions.

[Definition of each temperature and thermal resistance]

Ta : Ambient air temperature

※Air temperature is defined as temperature separated from the heating elements and not affected by convection, radiation, etc.

Tc : Temperature near the center of a package surface. Opposite side of the package mounting surface.

Tj : Semiconductor element surface temperature (Junction temperature.)

Rth(j-c) : Thermal resistance (Temperature difference per 1 Watts) between the semiconductor element junction part and the package surface.

Rth(c-a) : Thermal resistance (Temperature difference per 1 Watts) between the package surface and ambient air temperature.

Rth(j-a) : Thermal resistance (Temperature difference per 1 Watts) between a semiconductor element junction part and ambient air temperature.

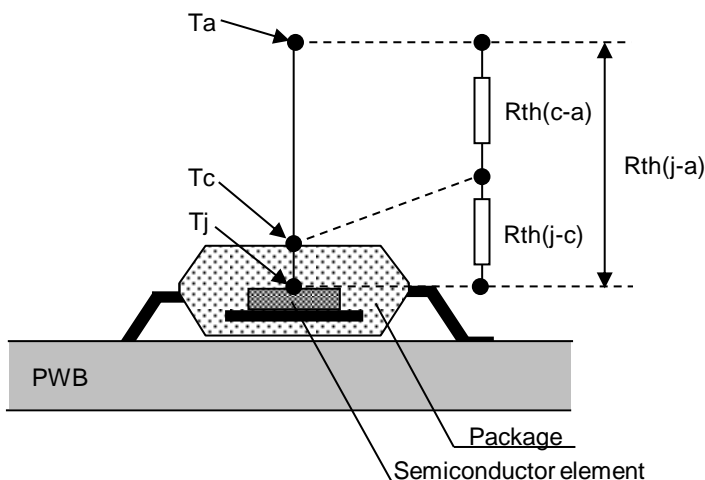

Fig1. Definition image

[Definition formula]

$$T_j = \{R_{th(j-c)} + R_{th(c-a)}\} \times P + T_a$$

$$= R_{th(j-a)} \times P + T_a$$

$$R_{th(j-c)} = \frac{T_j - T_c}{P} \quad (^\circ\text{C/W})$$

$$R_{th(c-a)} = \frac{T_c - T_a}{P} \quad (^\circ\text{C/W})$$

$$R_{th(j-a)} = \frac{T_j - T_a}{P} \quad (^\circ\text{C/W})$$

$$= R_{th(j-c)} + R_{th(c-a)}$$

P: power(W)

IMPORTANT NOTICE

1. When using the IC for new models, verify the safety including the long-term reliability for each product.
2. When the application system is designed by using this IC, please confirm the notes in this book.
Please read the notes to descriptions and the usage notes in the book.
3. This IC is intended to be used for general electronic equipment.
Consult our sales staff in advance for information on the following applications: Special applications in which exceptional quality and reliability are required, or if the failure or malfunction of this IC may directly jeopardize life or harm the human body. Any applications other than the standard applications intended.
 - (1) Space appliance (such as artificial satellite, and rocket)
 - (2) Traffic control equipment (such as for automotive, airplane, train, and ship)
 - (3) Medical equipment for life support
 - (4) Submarine transponder
 - (5) Control equipment for power plant
 - (6) Disaster prevention and security device
 - (7) Weapon
 - (8) Others : Applications of which reliability equivalent to (1) to (7) is required

Our company shall not be held responsible for any damage incurred as a result of or in connection with the IC being used for any special application, unless our company agrees to the use of such special application.
However, for the IC which we designate as products for automotive use, it is possible to be used for automotive.
4. This IC is neither designed nor intended for use in automotive applications or environments unless the IC is designated by our company to be used in automotive applications.
Our company shall not be held responsible for any damage incurred by customers or any third party as a result of or in connection with the IC being used in automotive application, unless our company agrees to such application in this book.
5. Please use this IC in compliance with all applicable laws and regulations that regulate the inclusion or use of controlled substances, including without limitation, the EU RoHS Directive. Our company shall not be held responsible for any damage incurred as a result of our IC being used by our customers, not complying with the applicable laws and regulations.
6. Pay attention to the direction of the IC. When mounting it in the wrong direction onto the PCB (printed-circuit-board), it might be damaged.
7. Pay attention in the PCB (printed-circuit-board) pattern layout in order to prevent damage due to short circuit between pins. In addition, refer to the Pin Description for the pin configuration.
8. Perform visual inspection on the PCB before applying power, otherwise damage might happen due to problems such as solder-bridge between the pins of the IC. Also, perform full technical verification on the assembly quality, because the same damage possibly can happen due to conductive substances, such as solder ball, that adhere to the IC during transportation.
9. Take notice in the use of this IC that it might be damaged and be emitted a little smoke when an abnormal state occurs such as output pin-VCC short (Power supply fault), output pin-GND short (Ground fault), or output-to-output-pin short (load short). Safety measures such as installation of fuses are recommended because the extent of the above-mentioned damage will depend on the current capability of the power supply.
Although the following pins comes with short circuit protection function, the IC may be damaged and emit smoke depending on the VCC voltage. Pins with short circuit protection function: Pin6(OUT1) and Pin10(OUT2).
10. The protection circuit is for maintaining safety against abnormal operation.
When sudden voltage or current change is applied to the pin, it may exceed the designated voltage and current level and therefore, customer shall perform sufficient evaluation and verification to ensure these are not exceeded in the usage.
Especially for the thermal protection circuit, if the area of safe operation or the absolute maximum rating is momentarily exceeded due to output pin to VCC short (Power supply fault), or output pin to GND short (Ground fault), the IC might be damaged and emit smoke before the thermal protection circuit could operate.
11. Unless specified in the product specifications, make sure that negative voltage or excessive voltage are not applied to the pins because the IC might be damaged, which could happen due to negative voltage or excessive voltage generated during the ON and OFF timing when the inductive load of a motor coil or actuator coils of optical pick-up is being driven.
12. Product which has specified ASO (Area of Safe Operation) should be operated in ASO
13. Verify the risks which might be caused by the malfunctions of external components.

IMPORTANT NOTICE (Continued)

14. Comply with the instructions for use in order to prevent breakdown and characteristics change due to external factors (ESD, EOS, thermal stress and mechanical stress) at the time of handling, mounting or at customer's process.
15. Dip soldering is not recommended.
16. Follow the power supply voltage, load and ambient temperature conditions to ensure that there is enough margin and the thermal design does not exceed the allowable value.
17. When designing your equipment, comply with the range of absolute maximum rating and the guaranteed operating conditions (operating power supply voltage and operating environment, etc.). Especially, please be careful not to exceed the range of absolute maximum rating on the transient state, such as power-on, power-off and mode switching. Otherwise, we will not be liable for any defect which may arise later in your equipment.
Even when the products are used within the guaranteed values, take into the consideration of incidence of break down and failure mode, possible to occur to semiconductor products. Measures on the systems such as redundant design, arresting the spread of fire or preventing glitch are recommended in order to prevent physical injury, fire, social damage, for example, by using the products.
18. Pin 12(PWMIN) pins are MCU interface. In the case that the current setting of the motor is large and lead line of GND is long, the potential of GND pin of the IC may be increased.
If 0V is input from the microcomputer, there is a case to be negative potential in the potential difference between the GND pin of this IC and the interface pin. If these pins detect under -0.3V, note that there is a possibility to break or malfunction

Revision History

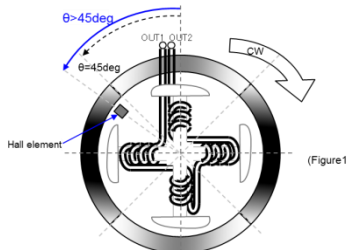
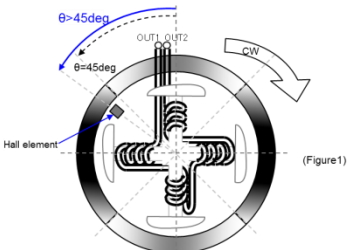
Control No.	Revision date	Page	Item	Before revision	After revision
	28.Mar.2016	P5	ELECTRICAL CHARACTERISTICS	PWM Input Low-level input voltage Limit max 0.5V	Limit max 0.55V
		P26	APPLICATION INFORMATION	Figure of Recommended position for hall element 	
		P19	AREA OF SAFE OPERATION	VDSmax=28V	VDSmax=36V
		P9	Protection Function	Release condition of Motor locked protection • at UVLO • After fixed time progress	• at UVLO • After fixed time progress • at PWMI stop control(added)
		P14	Functional explanation	Release condition of Motor locked protection • In detecting UVLO mode • After fixed time progress	• In detecting UVLO mode • After fixed time progress • In inputting PWMI stop control
	6.Apr.2016	P1	Package picture	-	Modified to the real product picture of AN44169A.

Request for your special attention and precautions in using the technical information and semiconductors described in this book

- (1) If any of the products or technical information described in this book is to be exported or provided to non-residents, the laws and regulations of the exporting country, especially, those with regard to security export control, must be observed.
- (2) The technical information described in this book is intended only to show the main characteristics and application circuit examples of the products. No license is granted in and to any intellectual property right or other right owned by Panasonic Corporation, Nuvoton Technology Corporation Japan or any other company. Therefore, no responsibility is assumed by our company as to the infringement upon any such right owned by any other company which may arise as a result of the use of technical information de-scribed in this book.
- (3) The products described in this book are intended to be used for general applications (such as office equipment, communications equipment, measuring instruments and household appliances), or for specific applications as expressly stated in this book.
Please consult with our sales staff in advance for information on the following applications, moreover please exchange documents separately on terms of use etc.: Special applications (such as for in-vehicle equipment, airplanes, aerospace, automotive equipment, traffic signaling equipment, combustion equipment, medical equipment and safety devices) in which exceptional quality and reliability are required, or if the failure or malfunction of the products may directly jeopardize life or harm the human body.
Unless exchanging documents on terms of use etc. in advance, it is to be understood that our company shall not be held responsible for any damage incurred as a result of or in connection with your using the products described in this book for any special application.
- (4) The products and product specifications described in this book are subject to change without notice for modification and/or improvement. At the final stage of your design, purchasing, or use of the products, therefore, ask for the most up-to-date Product Standards in advance to make sure that the latest specifications satisfy your requirements.
- (5) When designing your equipment, comply with the range of absolute maximum rating and the guaranteed operating conditions (operating power supply voltage and operating environment etc.). Especially, please be careful not to exceed the range of absolute maximum rating on the transient state, such as power-on, power-off and mode-switching. Otherwise, we will not be liable for any defect which may arise later in your equipment.
Even when the products are used within the guaranteed values, take into the consideration of incidence of break down and failure mode, possible to occur to semiconductor products. Measures on the systems such as redundant design, arresting the spread of fire or preventing glitch are recommended in order to prevent physical injury, fire, social damages, for example, by using the products.
- (6) Comply with the instructions for use in order to prevent breakdown and characteristics change due to external factors (ESD, EOS, thermal stress and mechanical stress) at the time of handling, mounting or at customer's process. We do not guarantee quality for disassembled products or the product re-mounted after removing from the mounting board.
When using products for which damp-proof packing is required, satisfy the conditions, such as shelf life and the elapsed time since first opening the packages.
- (7) When reselling products described in this book to other companies without our permission and receiving any claim of request from the resale destination, please understand that customers will bear the burden.
- (8) This book may be not reprinted or reproduced whether wholly or partially, without the prior written permission of our company.

No.070920

单击下面可查看定价，库存，交付和生命周期等信息

[>>Panasonic\(松下\)](#)