



Guidelines and precautions regarding the technical information and use of our products described in this online catalog.

- If you want to use our products described in this online catalog for applications requiring special qualities or reliability, or for applications where the failure or malfunction of the products may directly jeopardize human life or potentially cause personal injury (e.g. aircraft and aerospace equipment, traffic and transportation equipment, combustion equipment, medical equipment, accident prevention, anti-crime equipment, and/or safety equipment), it is necessary to verify whether the specifications of our products fit to such applications. Please ensure that you will ask and check with our inquiry desk as to whether the specifications of our products fit to such applications use before you use our products.
- The quality and performance of our products as described in this online catalog only apply to our products when used in isolation. Therefore, please ensure you evaluate and verify our products under the specific circumstances in which our products are assembled in your own products and in which our products will actually be used.
- If you use our products in equipment that requires a high degree of reliability, regardless of the application, it is recommended that you set up protection circuits and redundancy circuits in order to ensure safety of your equipment.
- The products and product specifications described in this online catalog are subject to change for improvement without prior notice. Therefore, please be sure to request and confirm the latest product specifications which explain the specifications of our products in detail, before you finalize the design of your applications, purchase, or use our products.
- The technical information in this online catalog provides examples of our products' typical operations and application circuits. We do not guarantee the non-infringement of third party's intellectual property rights and we do not grant any license, right, or interest in our intellectual property.
- If any of our products, product specifications and/or technical information in this online catalog is to be exported or provided to non-residents, the laws and regulations of the exporting country, especially with regard to security and export control, shall be observed.

<Regarding the Certificate of Compliance with the EU RoHS Directive/REACH Regulations>

- The switchover date for compliance with the RoHS Directive/REACH Regulations varies depending on the part number or series of our products.
- When you use the inventory of our products for which it is unclear whether those products are compliant with the RoHS Directive/REACH Regulation, please select "Sales Inquiry" in the website inquiry form and contact us.

We do not take any responsibility for the use of our products outside the scope of the specifications, descriptions, guidelines and precautions described in this online catalog.

EMC Components / ESD Components CONTENTS

| Classification | Product Item | Part No. | Page | |
|-------------------|---|---------------------------------|----------------|--------------------|
| EMC Components | Common mode Noise Filters | EXC X4CZ | 1 | |
| | | EXC X4CH | 4 | |
| | | EXC X4CE | 6 | |
| | | EXC X4CT NRFND | 8 | |
| | | EXC 14CH | 10 | |
| | | EXC 14CG, 14CE | 12 | |
| | | EXC 14CT | 15 | |
| | | EXC 14CX | 17 | |
| | | EXC 16CT | 19 | |
| | | EXC 24CH | 21 | |
| | | EXC 24CG | 23 | |
| | | EXC 24CE, 24CF | 25 | |
| | | EXC 34CG, 34CE | 27 | |
| | | Common mode Noise Filters Array | EXC 18CG, 18CE | 29 |
| | EXC 28CH | | 31 | |
| | EXC 28CG | | 33 | |
| | EXC 28CE | | 35 | |
| | Packaging methods, Land pattern and Soldering conditions for Common mode Noise Filters / Array | | | 37 |
| | Common mode Noise Filters with ESD Suppressor | EXC 14CS NRFND | 39 | |
| | | EXC 24CS NRFND | 41 | |
| | Common mode Noise Filters Array with ESD Suppressor | EXC 18CS NRFND | 43 | |
| | Packaging methods and Soldering conditions for Common mode Noise Filters with ESD Suppressor | | | NRFND 45 |
| | 2 mode Noise Filters | EXC 14CP | 47 | |
| | | EXC 24CB, 24CP, 24CN | 49 | |
| | Packaging methods, Land pattern and Soldering conditions for 2 mode Noise Filters | | | 52 |
| | Performance for Common mode Noise Filters/Common mode Noise Filters with ESD Suppressor/2 mode Noise Filters | | | 54 |
| | Safety precautions for Common mode Noise Filters/Common mode Noise Filters with ESD Suppressor/2 mode Noise Filters | | | 55 |
| ESD Components | ESD Suppressor | EZA EG2A, EG3A | 57 | |
| | | EZA EG1N, EG2N | 59 | |
| | ESD Suppressor Array | EZA EGCA | 61 | |
| | ESD Suppressor High Withstanding Type | EZA EG3W | 63 | |
| | Packaging methods, Soldering conditions and Safety precautions for ESD Suppressor / Array | | | 65 |
| | Multilayer Varistor (Automotive Grade) | EZJ Z-M / EZJ P-M | 68 | |
| | Common specifications Packaging methods and Safety precautions for Multilayer Varistor (Automotive Grade) | | | 70 |
| | Multilayer Varistor (DC voltage lines / High speed signal lines) | EZJ Z / EZJ P | 82 | |
| | Multilayer Varistor (DC voltage lines) | EZJ S | 87 | |
| | Common specifications Packaging methods and Safety precautions for Multilayer Varistor | | | 93 |

Common mode Noise Filters

Type: **EXCX4CZ**



Features

- Small and thin (L 0.65 mm×W 0.50 mm×H 0.30 mm)
- High-common mode attenuation at 2.4GHz, Suitable for noise suppression at Wi-Fi band
- Strong multilayer/sintered structure, excellent reflow resistance and high mounting reliability
- Lead, halogen and antimony-free
- RoHS compliant

Recommended Applications

- Smartphones, Tablet PCs and DSC
- Suppresses noise radiation to Wi-Fi Equipment

Explanation of Part Numbers

| | | | | | | | | | | | |
|--------------|----------|----------|-------------------------------|---------------------|----------------|-----------------------------------|--|----------|----------|--|--------|
| 1 | 2 | 3 | 4 | 5 | 6 | 7 | 8 | 9 | 10 | 11 | 12 |
| E | X | C | X | 4 | C | Z | 2 | 0 | 0 | X | |
| Product Code | | Size | | Number of Terminals | Type | Characteristics | Nominal Impedance | | Form | | Suffix |
| Noise Filter | | Code | Dimensions(mm) | 4 Terminals | C Coupled type | Wide band width, high attenuation | The first two digits are significant figure of impedance value, and the third one denotes the number of zeros following. | | Code | Packing | |
| | | X | 0.65×0.50×0.30 (L)×(W)×(H) | | | | | | X | Pressed Carrier Taping 2 mm pitch, 10,000 pcs | |

Construction

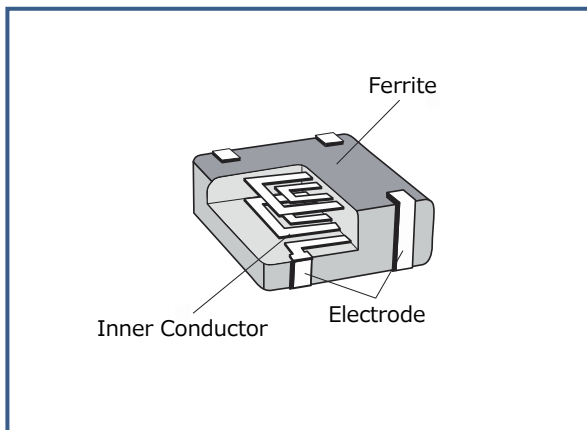

Dimensions in mm (not to scale)

| Part No. (inch size) | Dimensions(mm) | | | | | | Mass (Weight) (mg/ pc.) |
|-------------------------|----------------|---------------|---------------|---------------|---------------|---------------|-------------------------------|
| | A | B | C | D | E | F | |
| EXCX4CZ (0202) | 0.50 ±0.05 | 0.65 ±0.05 | 0.30 ±0.05 | 0.12 ±0.10 | 0.40 ±0.10 | 0.15 ±0.10 | 0.28 |

Circuit Configuration (No Polarity)

※ The pin numbers shown here are for reference purposes only. Confirm the actual pin number arrangement with the exchanged specification documents.

Ratings

| Part Number | Impedance (Ω) at 100 MHz | Rated Voltage (V) DC | Rated Current (mA) DC | DC Resistance (Ω)max. |
|------------------------|-----------------------------------|----------------------|-----------------------|--------------------------------|
| | Common Mode | | | |
| NEW EXCX4CZ040X | 4 Ω \pm 2 Ω | 5 | 100 | 1.0 \pm 30 % |
| NEW EXCX4CZ090X | 9 Ω \pm 3 Ω | 5 | 100 | 1.9 \pm 30 % |
| EXCX4CZ200X | 20 Ω \pm 30 % | 5 | 100 | 3.0 \pm 30 % |

● Category Temperature Range -40 °C to +85 °C

Impedance Characteristics (Typical)

● EXCX4CZ040X

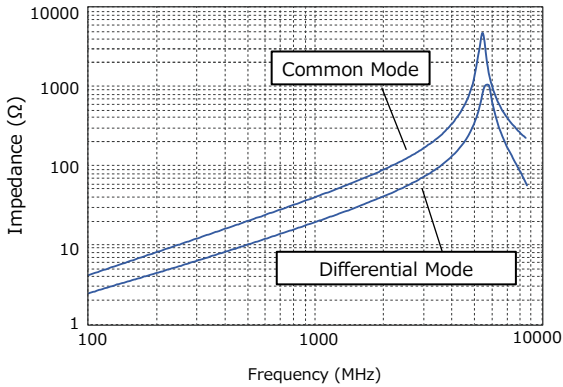

● EXCX4CZ090X

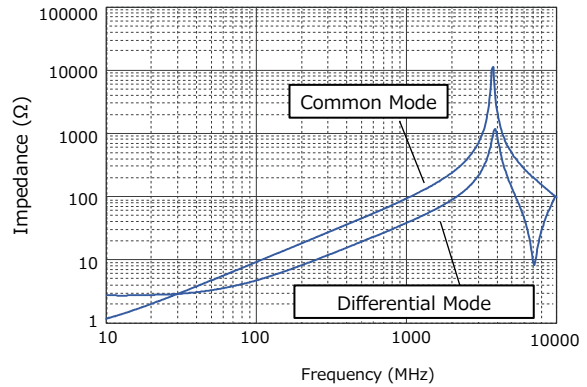

● EXCX4CZ200X

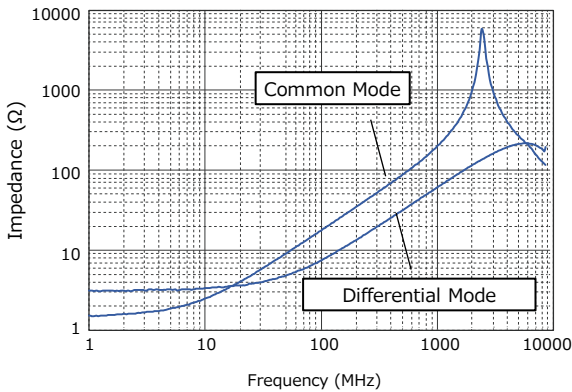

● Measurement Circuit

(A) Common Mode

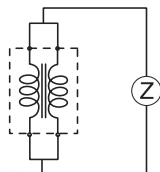

(B) Differential Mode

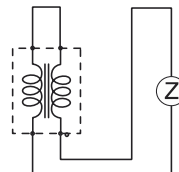

Attenuation Characteristics (Typical)

● EXCX4CZ040X

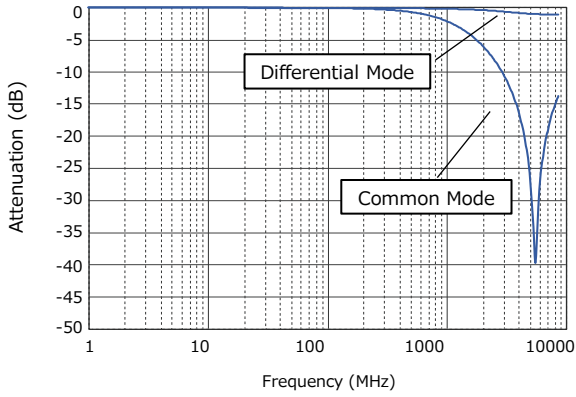

● EXCX4CZ090X

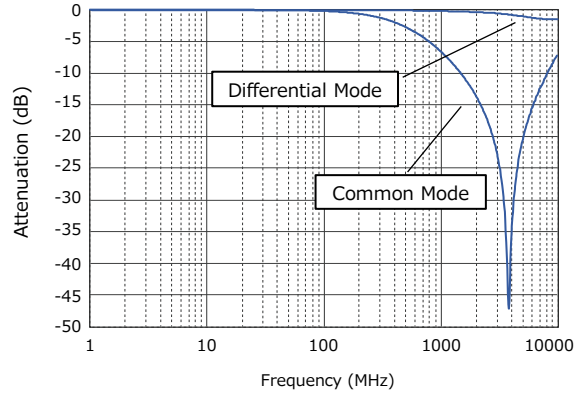

● EXCX4CZ200X

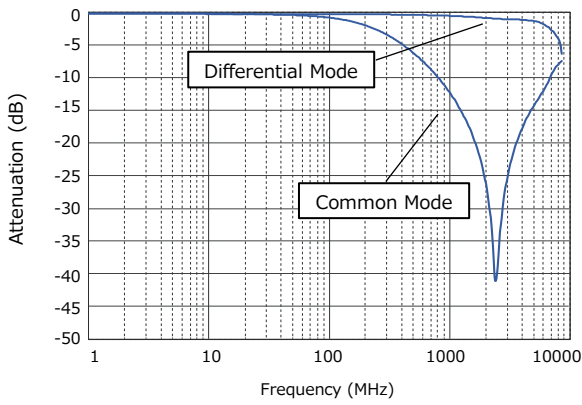

■ As for Packaging Methods, Land Pattern, Soldering Conditions and Safety Precautions, Please see Data Files

Common mode Noise Filters

Type: **EXCX4CH**



Features

- Small and thin (L 0.65 mm×W 0.50 mm×H 0.30 mm)
- High common mode attenuation in high-speed differential transmission lines, Cut-off frequency is more than 8.5 GHz, and an influence to differential transmission signal quality is little
- Strong multilayer/sintered structure, excellent reflow resistance and high mounting reliability
- Lead, halogen and antimony-free
- RoHS compliant

Recommended Applications

- Smartphones, Tablet PCs and DSC
- Noise suppression of high-speed differential data lines such as USB, LVDS and HDMI

Explanation of Part Numbers

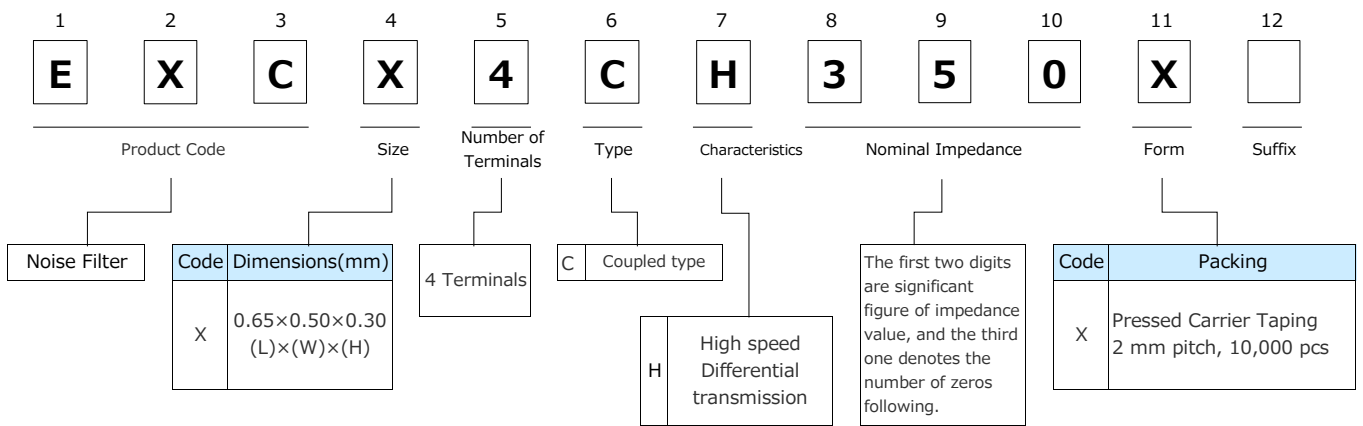

Construction

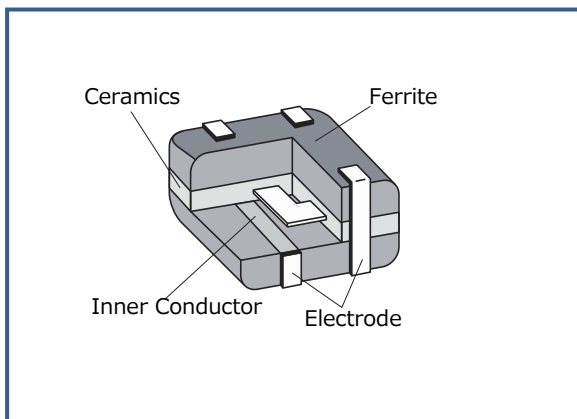

Dimensions in mm (not to scale)

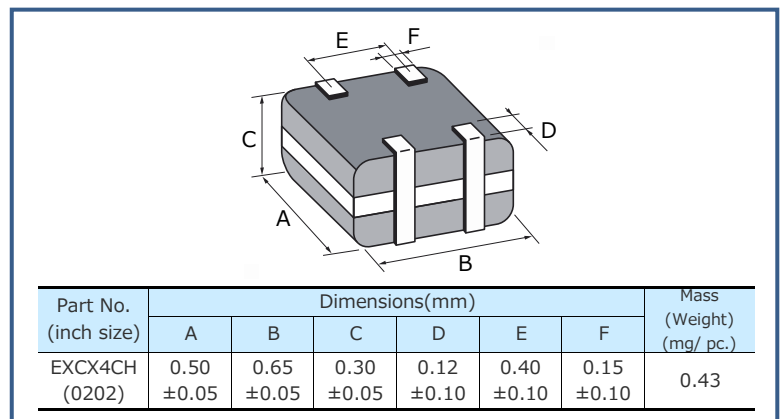

Circuit Configuration (No Polarity)

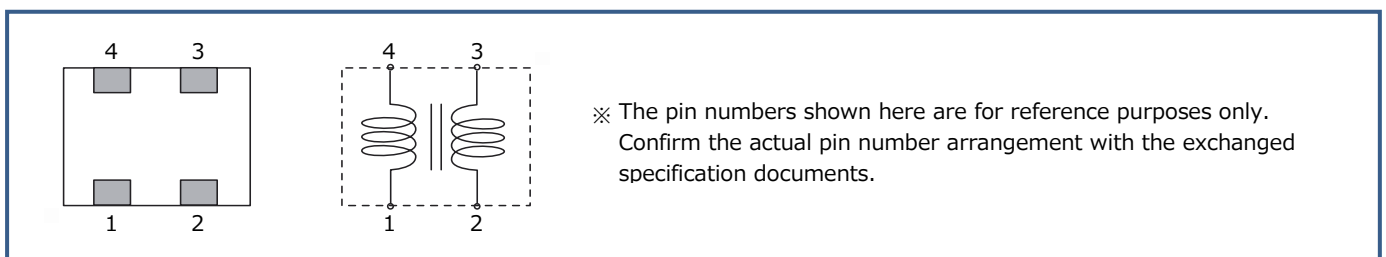

| Ratings | | | | | |
|-------------|-----------------------------------|--|----------------------|-----------------------|--------------------------------|
| Part Number | Impedance (Ω) at 100 MHz | | Rated Voltage (V) DC | Rated Current (mA) DC | DC Resistance (Ω)max. |
| | Common Mode | | | | |
| EXCX4CH120X | 12 Ω \pm 5 Ω | | 5 | 100 | 2.0 |
| EXCX4CH350X | 35 Ω \pm 30 % | | 5 | 100 | 2.7 |

● Category Temperature Range -40 °C to +85 °C

Impedance Characteristics (Typical)

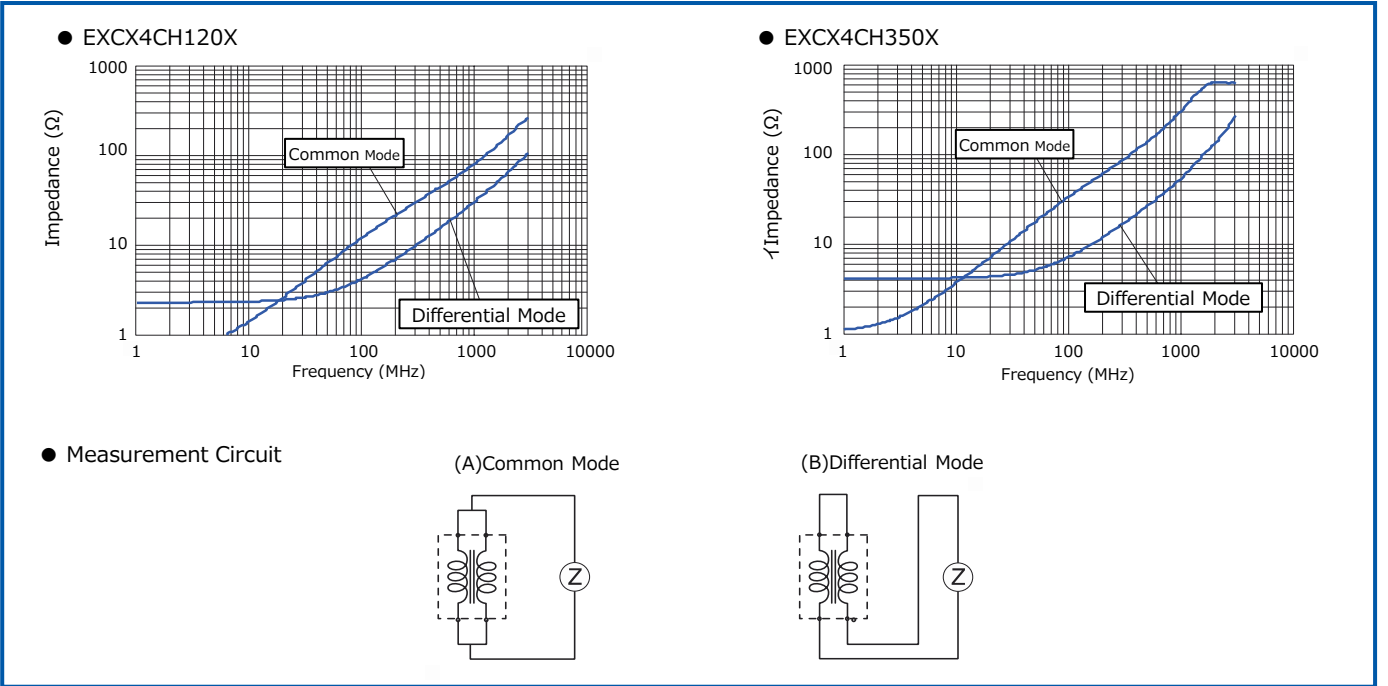

Insertion Loss (Typical)

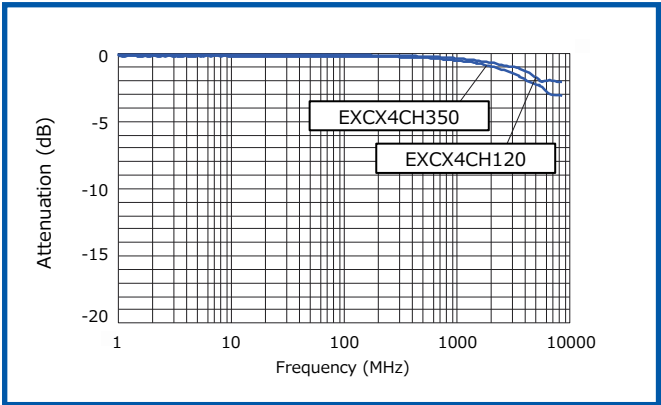

Common mode Attenuation Characteristics (Typical)

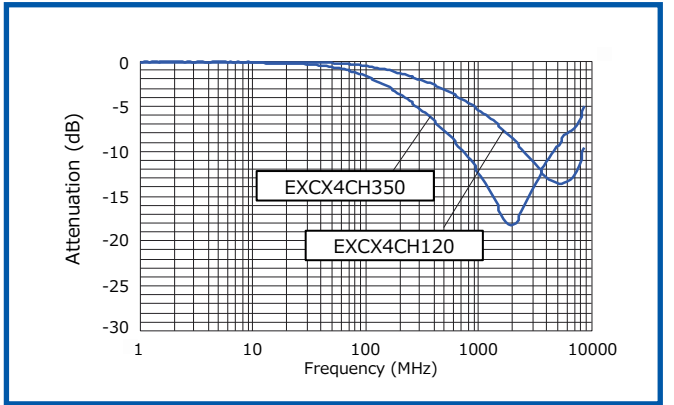

■ As for Packaging Methods, Land Pattern, Soldering Conditions and Safety Precautions, Please see Data Files

Common mode Noise Filters

Type: **EXCX4CE**



Features

- Small and thin (L 0.65 mm×W 0.50 mm×H 0.30 mm)
- Noise suppression of high-speed differential transmission lines with little influence of waveform rounding on signal transmission
- Strong multilayer/sintered structure, excellent reflow resistance and high mounting reliability
- Lead, halogen and antimony-free
- RoHS compliant

Recommended Applications

- Smartphones, Tablet PCs and DSC
- Noise suppression of high-speed differential data lines such as MIPI, USB and LVDS

Explanation of Part Numbers

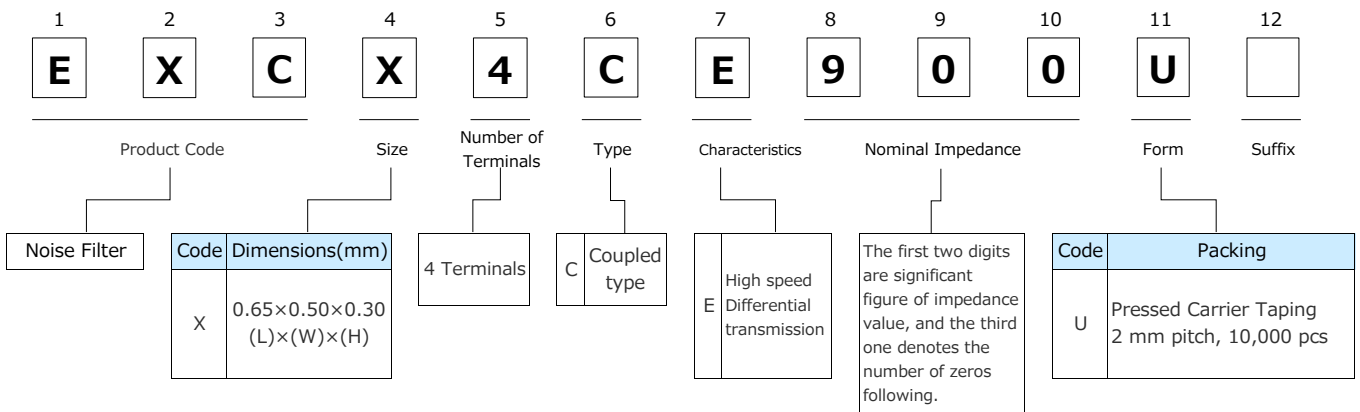

Construction

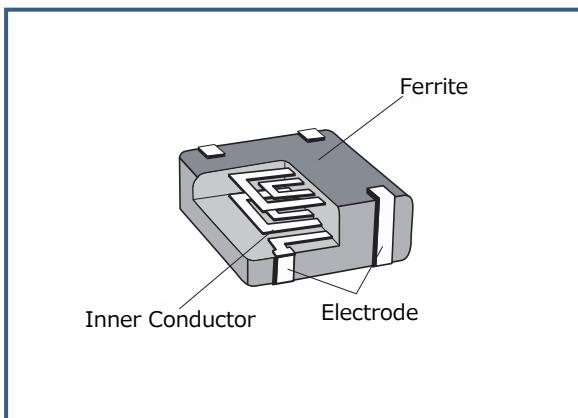

Dimensions in mm (not to scale)

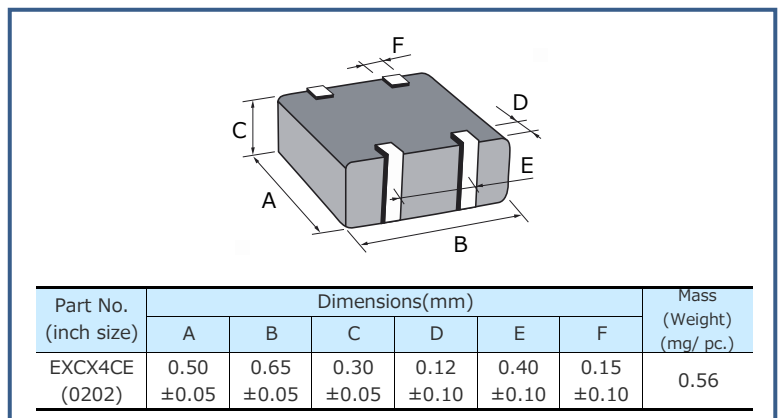

Circuit Configuration (No Polarity)

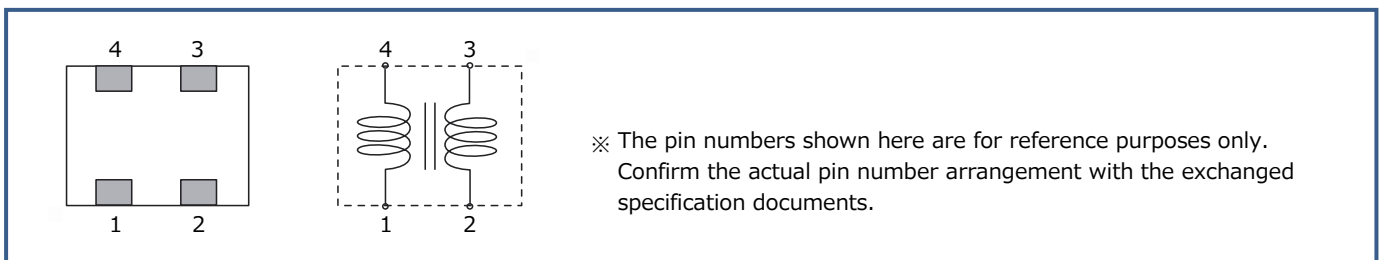

Ratings

| Part Number | Impedance (Ω) at 100 MHz | | Rated Voltage (V) DC | Rated Current (mA) DC | DC Resistance (Ω)max. |
|-------------|-----------------------------------|-------------------|----------------------|-----------------------|--------------------------------|
| | Common Mode | Differential Mode | | | |
| EXCX4CE600U | 60 Ω ±20 % | 18 Ω max. | 5 | 100 | 2.4±30 % |
| EXCX4CE900U | 90 Ω ±20 % | 20 Ω max. | 5 | 100 | 3.0±30 % |

● Category Temperature Range -40 °C to +85 °C

Impedance Characteristics (Typical)

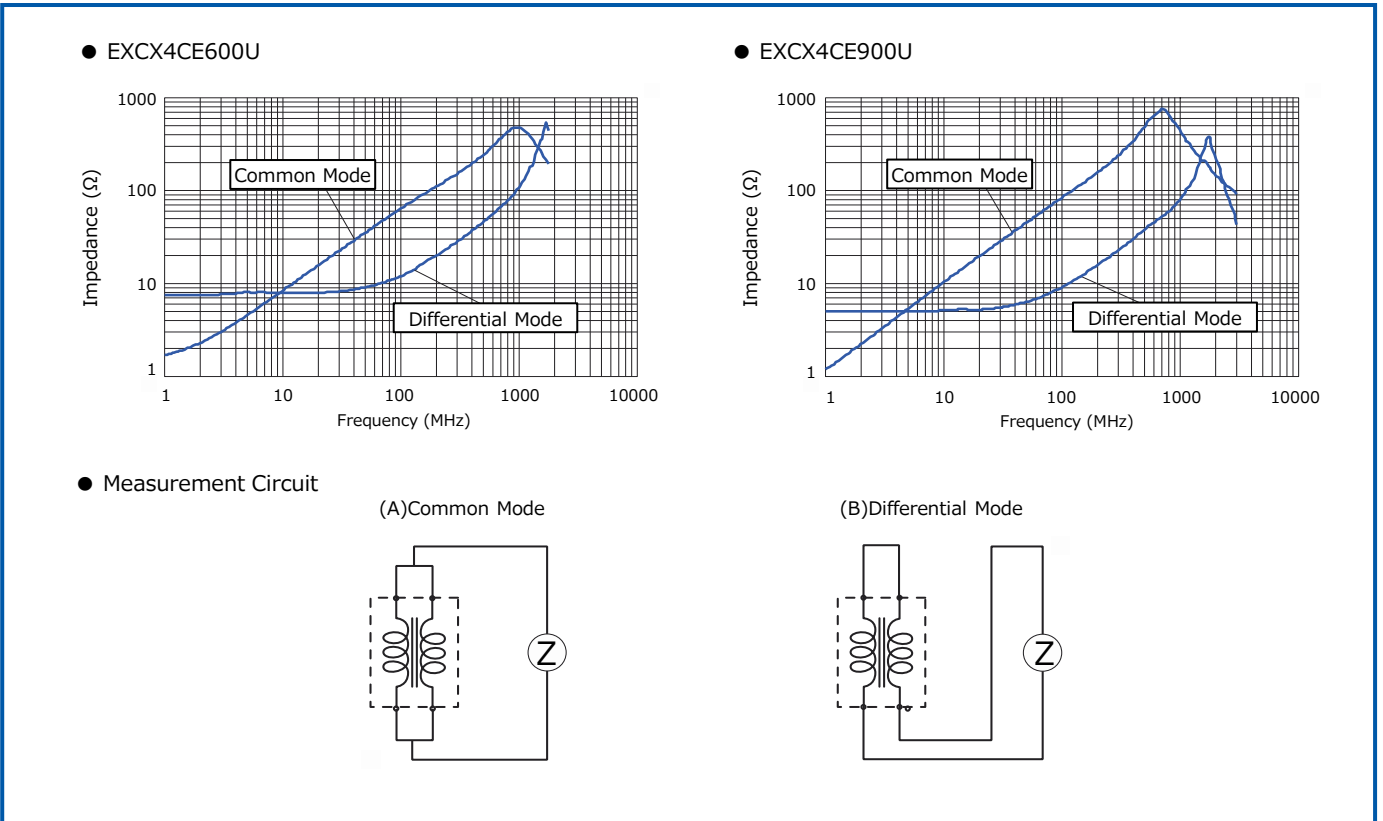

■ As for Packaging Methods, Land Pattern, Soldering Conditions and Safety Precautions, Please see Data Files



Common mode Noise Filters

Type: **EXCX4CT**



This series is not a recommended product.
Not recommended for new design.

Features

- Small and thin (L 0.65 mm×W 0.50 mm×H 0.30 mm)
- High attenuation at common-mode for noise suppression of harmonic signal components and cellular frequency
- Cut-off frequency is more than 3 GHz, the insertion loss is low in differential transmission line
- Strong multilayer/sintered structure, excellent reflow resistance and high mounting reliability
- Lead, halogen and antimony-free
- RoHS compliant

Recommended Applications

- Smartphones, Tablet PCs and DSC
- Noise suppression of high-speed differential data lines such as MIPI, USB and LVDS

Explanation of Part Numbers

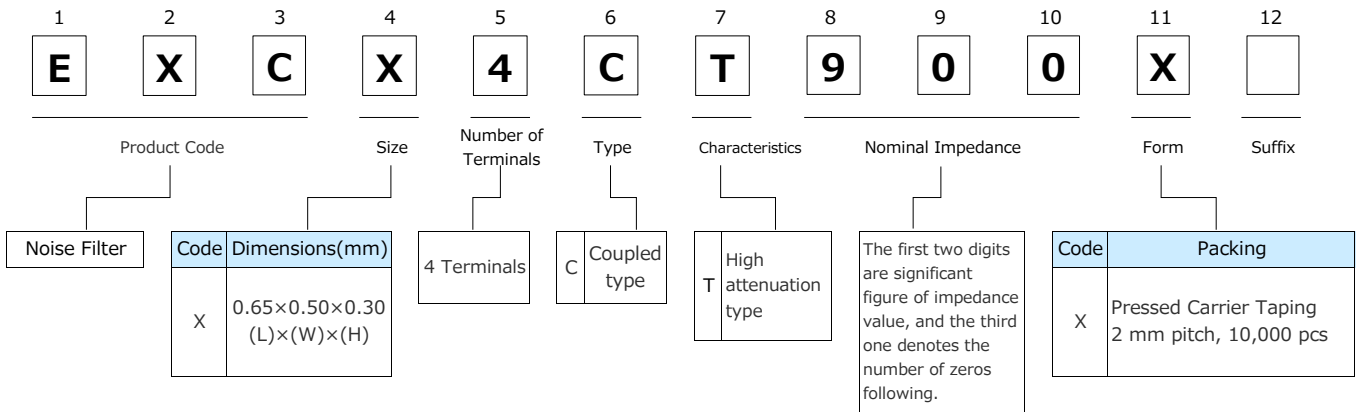

Construction

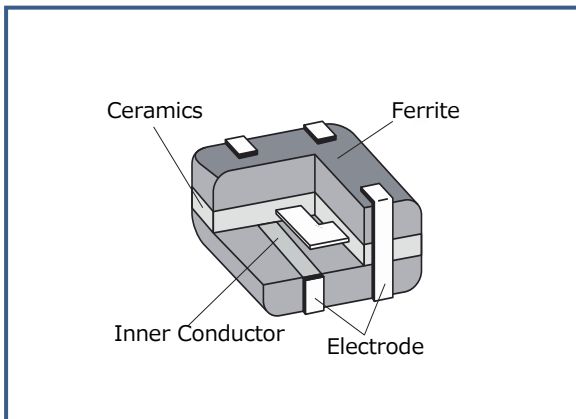

Dimensions in mm (not to scale)

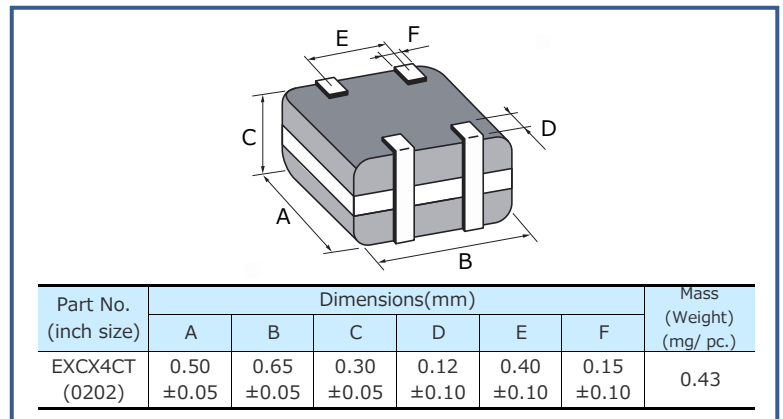

Circuit Configuration (No Polarity)

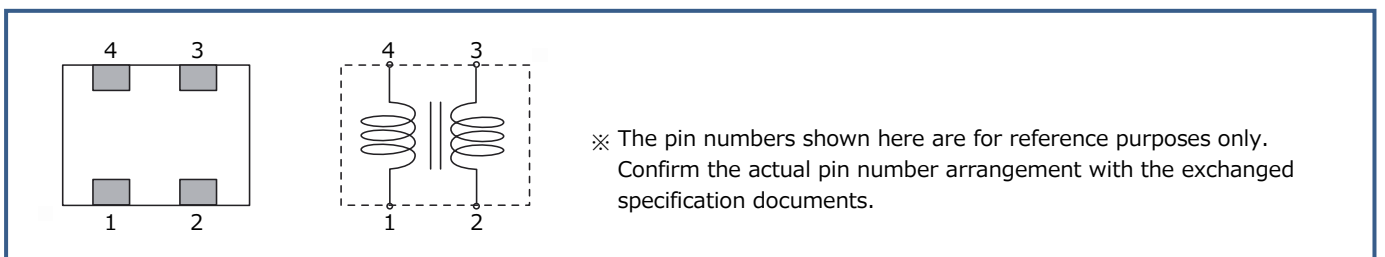

| Ratings | | | | | |
|-------------|-----------------------------------|--|----------------------|-----------------------|--------------------------------|
| Part Number | Impedance (Ω) at 100 MHz | | Rated Voltage (V) DC | Rated Current (mA) DC | DC Resistance (Ω)max. |
| | Common Mode | | | | |
| EXCX4CT650X | 65 $\Omega \pm 20\%$ | | 10 | 100 | 2.7 $\Omega \pm 30\%$ |
| EXCX4CT900X | 90 $\Omega \pm 20\%$ | | 10 | 100 | 3.0 $\Omega \pm 30\%$ |

● Category Temperature Range $-40\text{ }^{\circ}\text{C}$ to $+85\text{ }^{\circ}\text{C}$

Impedance Characteristics (Typical)

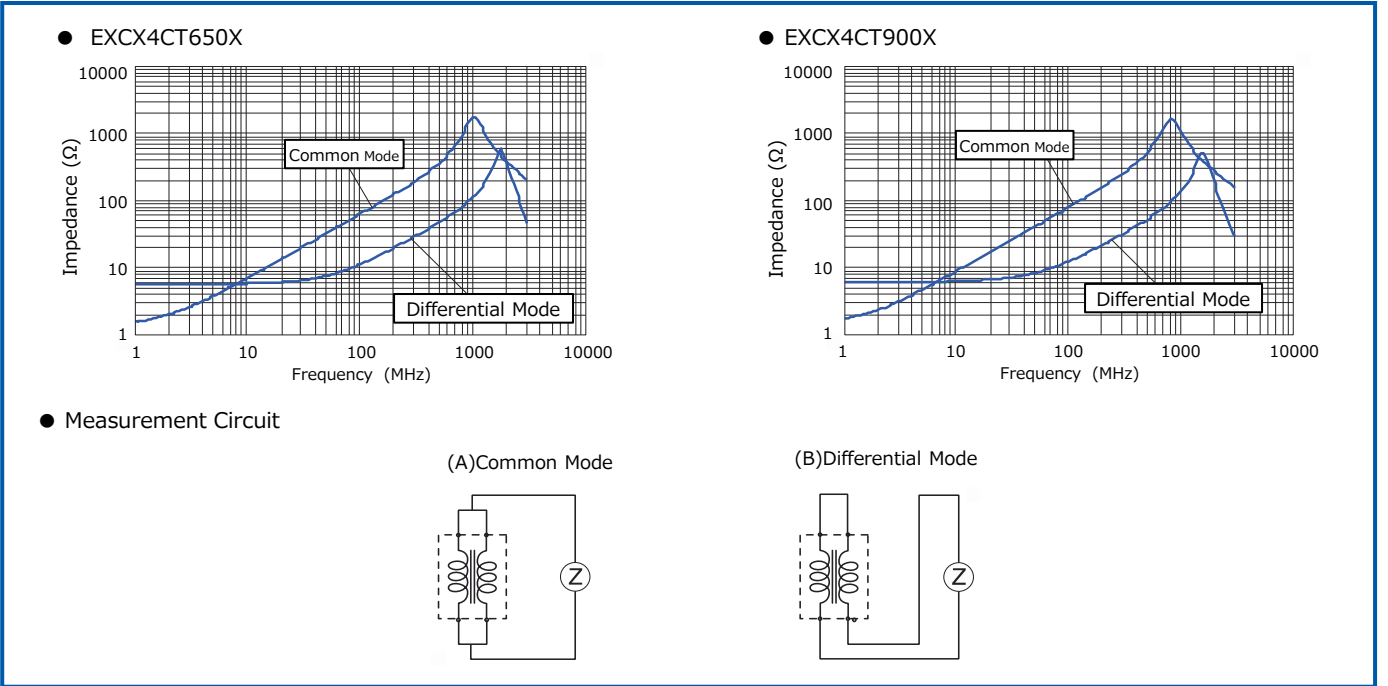

Insertion Loss (Typical)

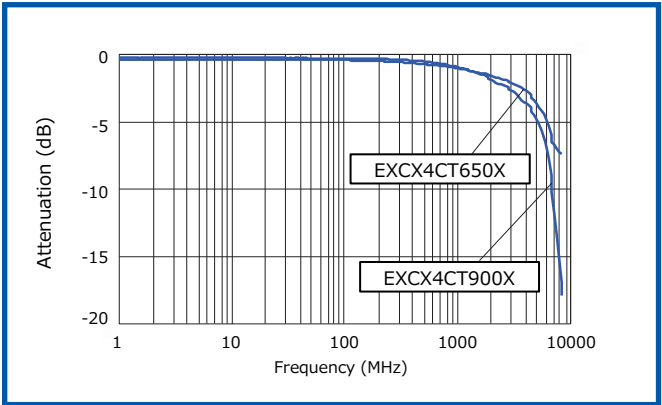

Common mode Attenuation Characteristics (Typical)

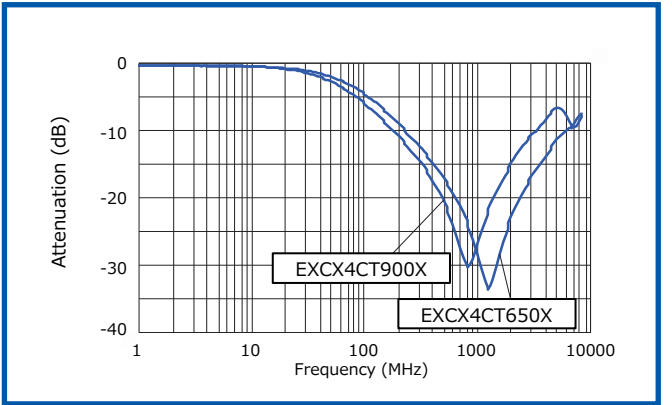

■ As for Packaging Methods, Land Pattern, Soldering Conditions and Safety Precautions, Please see Data Files

Common mode Noise Filters

Type: **EXC14CH**



Features

- Small and thin (L 0.85 mm×W 0.65 mm×H 0.45 mm)
- High common mode attenuation in high-speed differential transmission lines, Cut-off frequency is more than 8.5 GHz, and an influence to differential transmission signal quality is little
- Strong multilayer/sintered structure, excellent reflow resistance and high mounting reliability
- Lead, halogen and antimony-free
- RoHS compliant

Recommended Applications

- Smartphones, Tablet PCs and DSC
- Noise suppression of high-speed differential data lines such as USB, LVDS and HDMI

Explanation of Part Numbers

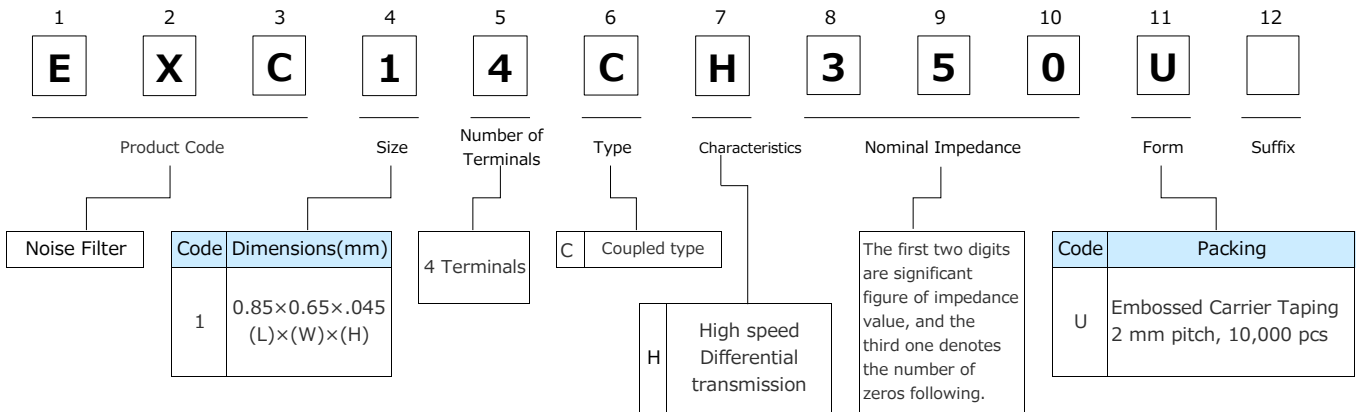

Construction

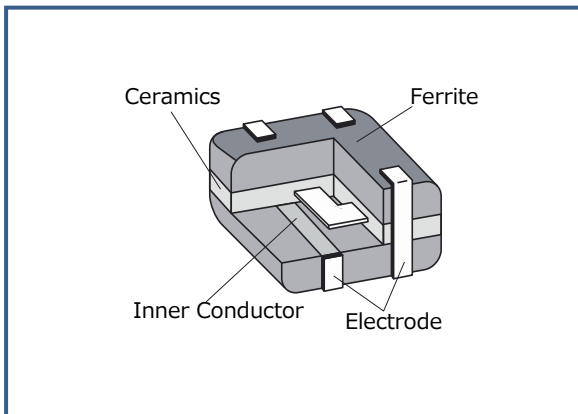

Dimensions in mm (not to scale)

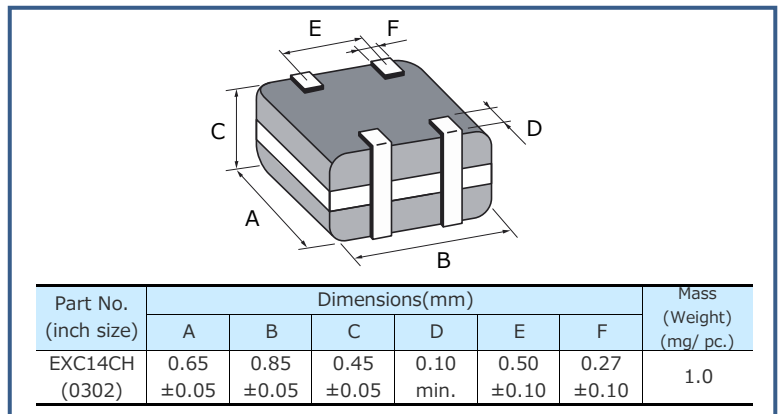

Circuit Configuration (No Polarity)

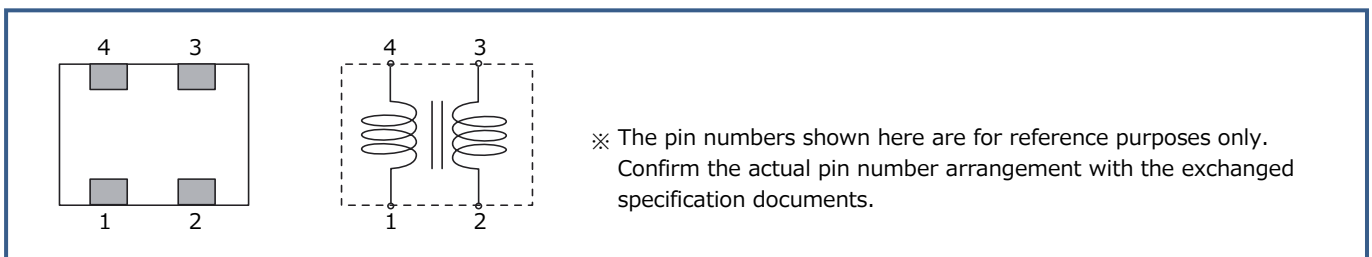

| Ratings | | | | | |
|-------------|-----------------------------------|-------------------|----------------------|-----------------------|--------------------------------|
| Part Number | Impedance (Ω) at 100 MHz | | Rated Voltage (V) DC | Rated Current (mA) DC | DC Resistance (Ω)max. |
| | Common Mode | Differential Mode | | | |
| EXC14CH120U | 12 Ω ±25 % | 10 Ω max. | 5 | 100 | 1.0 |
| EXC14CH350U | 35 Ω ±30 % | 15 Ω max. | 5 | 100 | 1.5 |

● Category Temperature Range -40 °C to +85 °C

Impedance Characteristics (Typical)

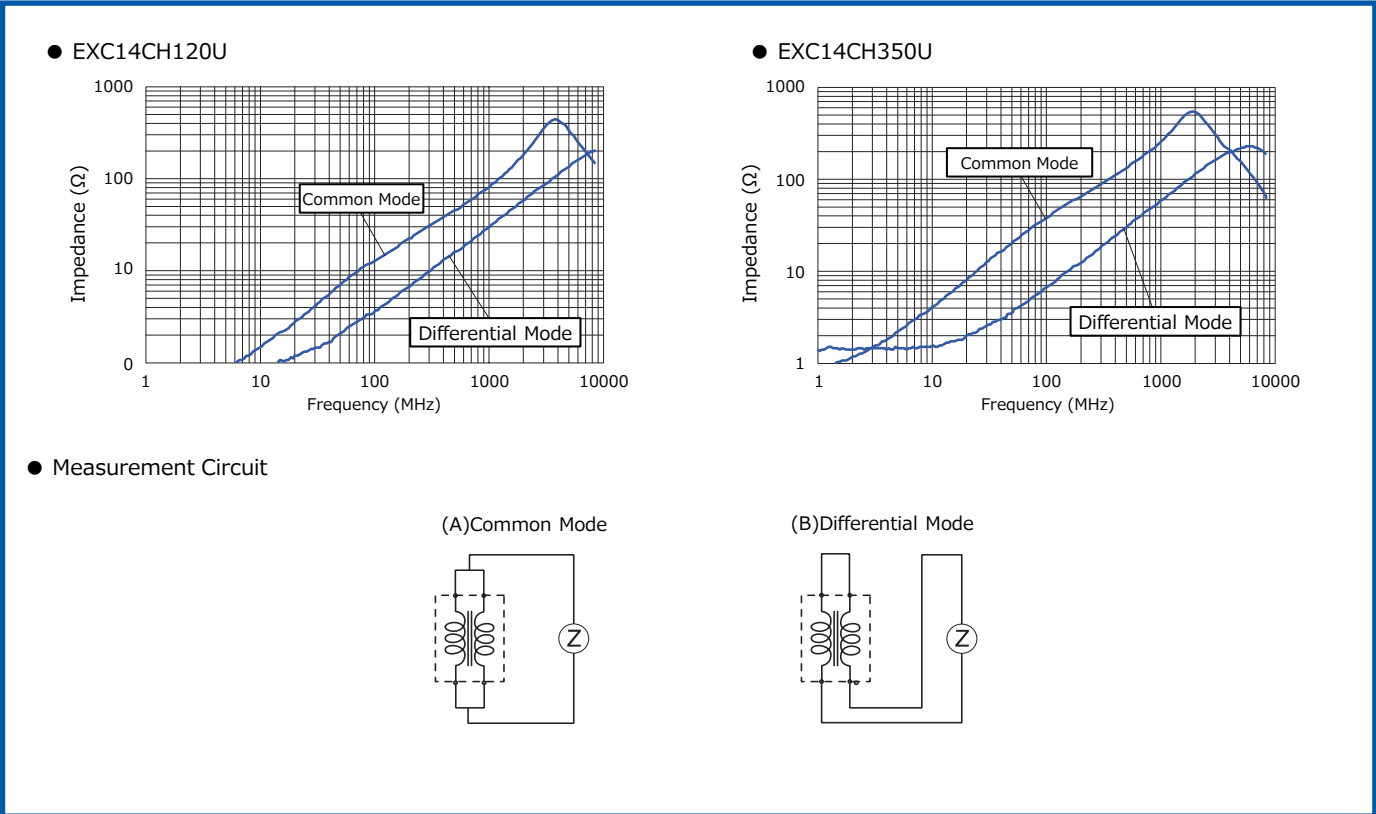

Insertion Loss (Typical)

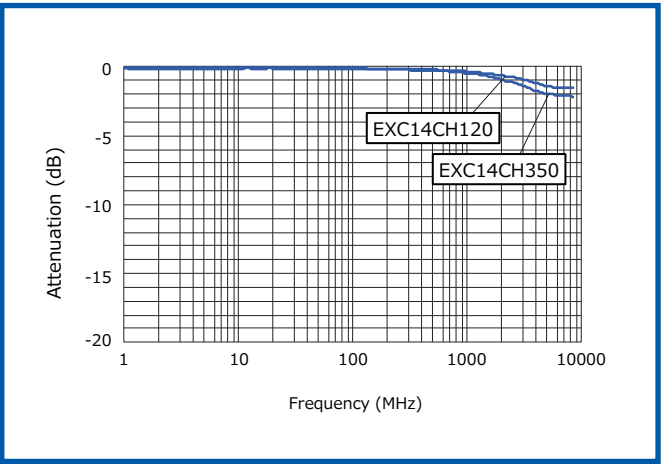

Common mode Attenuation Characteristics (Typical)

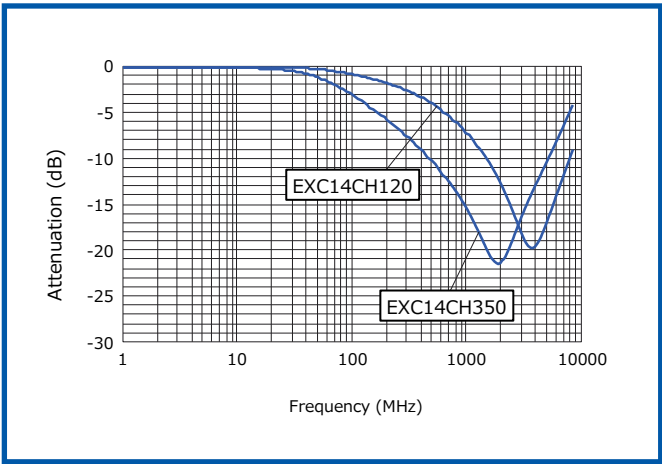

■ As for Packaging Methods, Land Pattern, Soldering Conditions and Safety Precautions, Please see Data Files

Common mode Noise Filters

Type: **EXC14CG/EXC14CE**



Features

- Small and thin (L 0.85 mm×W 0.65 mm×H 0.45 mm)
- Noise suppression of high-speed differential transmission lines with little influence of waveform rounding on signal transmission
- Low DC resistance and low insertion loss
- High-Q value and high impedance of GHz zone : EXC14CG type
- Strong multilayer/sintered structure, excellent reflow resistance and high mounting reliability
- Lead, halogen and antimony-free
- RoHS compliant

Recommended Applications

- Smartphones, Tablet PCs and DSC
- Noise suppression of high-speed differential data lines such as USB, LVDS and MHL

Explanation of Part Numbers

| | | | | | | | | | | | |
|--------------|------|----------------------------|----------------|---------------------|----------------|---|--|---|----|------|---|
| 1 | 2 | 3 | 4 | 5 | 6 | 7 | 8 | 9 | 10 | 11 | 12 |
| E | X | C | 1 | 4 | C | E | 9 | 0 | 0 | U | |
| Product Code | | | Size | Number of Terminals | Type | Characteristics | Nominal Impedance | | | Form | Suffix |
| Noise Filter | Code | | Dimensions(mm) | 4 Terminals | C Coupled type | E High speed Differential transmission G High-Q type | The first two digits are significant figure of impedance value, and the third one denotes the number of zeros following. | | | Code | Packing |
| | 1 | 0.85×0.65×.045 (L)×(W)×(H) | | | | | | | | U | Embossed Carrier Taping 2 mm pitch, 10,000 pcs |

Construction

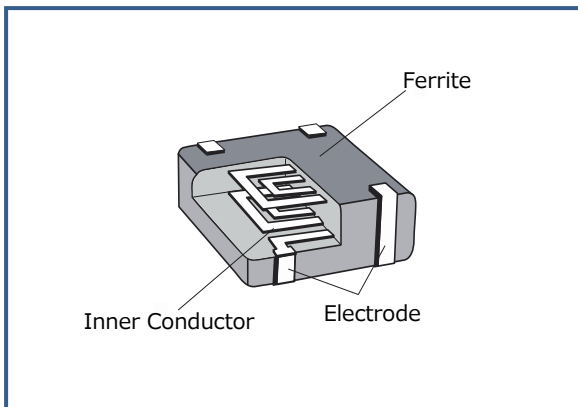

Dimensions in mm (not to scale)

| Part No. (inch size) | Dimensions(mm) | | | | | | Mass (Weight) (mg/ pc.) |
|-------------------------|----------------|-------|-------|------|-------|-------|-------------------------------|
| | A | B | C | D | E | F | |
| EXC14CE | 0.65 | 0.85 | 0.45 | 0.10 | 0.50 | 0.27 | 1.4 |
| EXC14CG (0302) | ±0.05 | ±0.05 | ±0.05 | min. | ±0.10 | ±0.10 | |

Circuit Configuration (No Polarity)

※ The pin numbers shown here are for reference purposes only. Confirm the actual pin number arrangement with the exchanged specification documents.

| Ratings | | | | | |
|-------------|-----------------------------------|-------------------|----------------------|-----------------------|--------------------------------|
| Part Number | Impedance (Ω) at 100 MHz | | Rated Voltage (V) DC | Rated Current (mA) DC | DC Resistance (Ω)max. |
| | Common Mode | Differential Mode | | | |
| EXC14CG120U | 12 Ω ±30 % | 10 Ω max. | 5 | 130 | 2.0 |
| EXC14CG350U | 35 Ω ±30 % | 15 Ω max. | 5 | 100 | 2.0 |
| EXC14CG430U | 43 Ω ±25 % | 15 Ω max. | 5 | 100 | 2.7 |
| EXC14CE650U | 65 Ω ±20 % | 20 Ω max. | 5 | 130 | 2.5 |
| EXC14CE900U | 90 Ω ±20 % | 20 Ω max. | 5 | 130 | 2.5 |
| EXC14CE121U | 120 Ω ±20 % | 20 Ω max. | 5 | 100 | 3.8 |

● Category Temperature Range -40 °C to +85 °C

Impedance Characteristics (Typical)

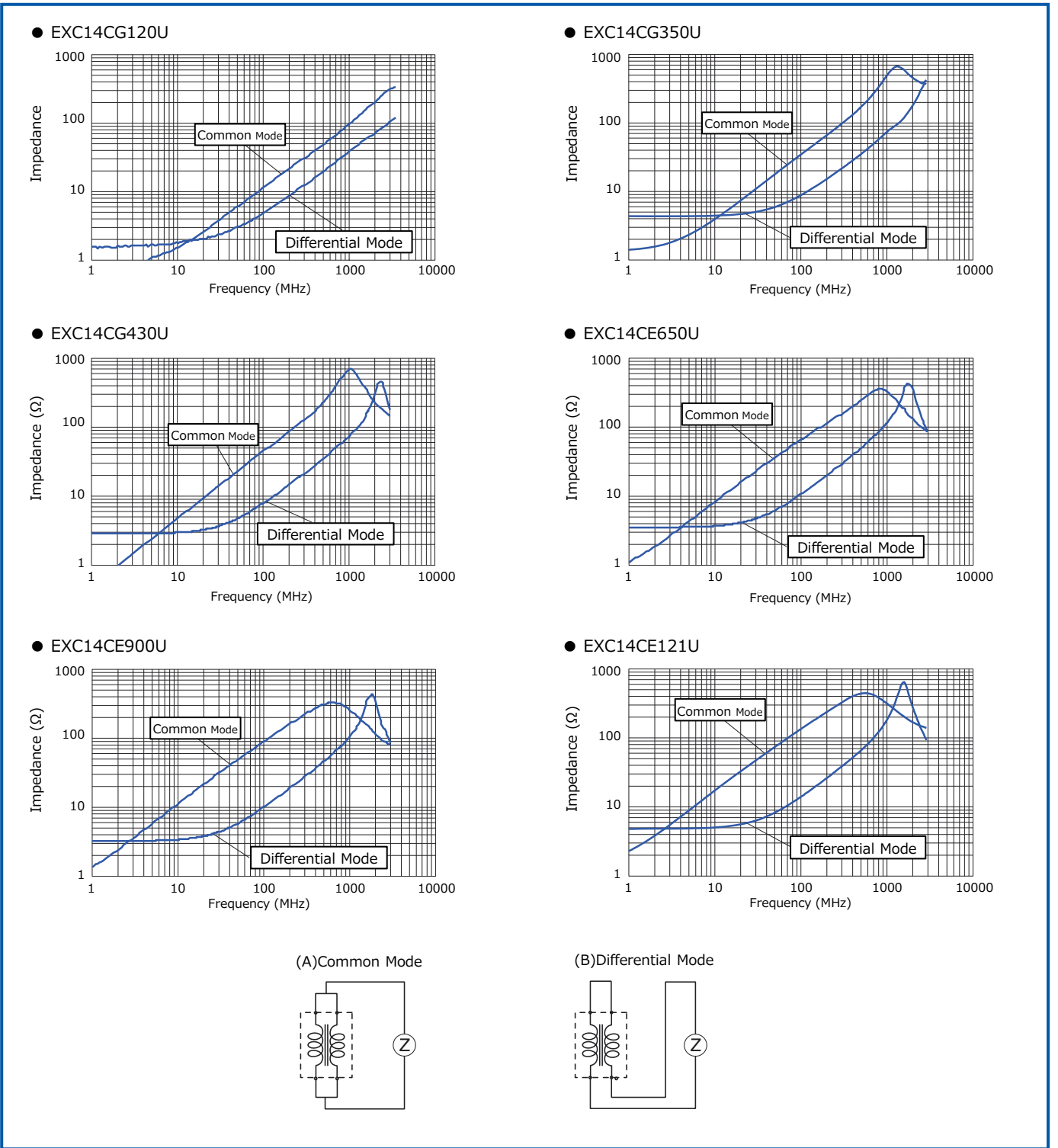

Design and specifications are each subject to change without notice. Ask factory for the current technical specifications before purchase and/or use. Should a safety concern arise regarding this product, please be sure to contact us immediately.

Attenuation Characteristics (Typical)

● EXC14CG120U

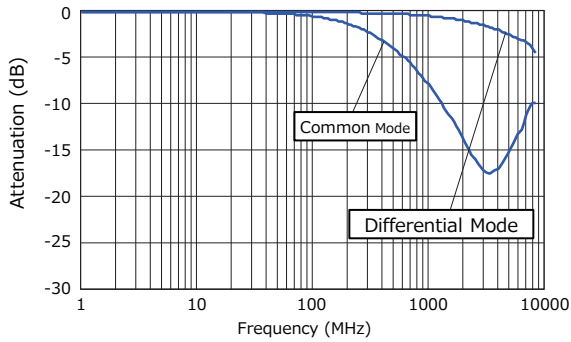

● EXC14CG350U

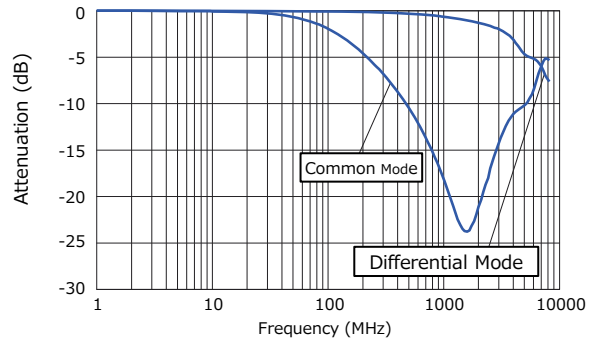

● EXC14CG430U

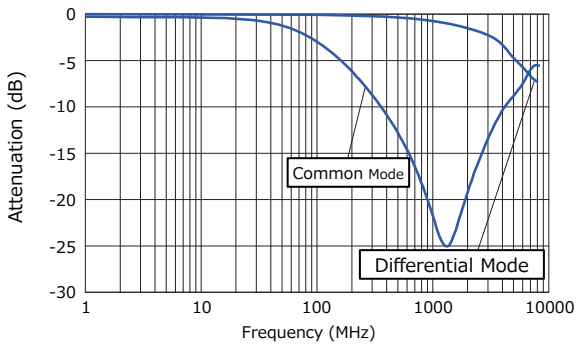

● EXC14CE650U

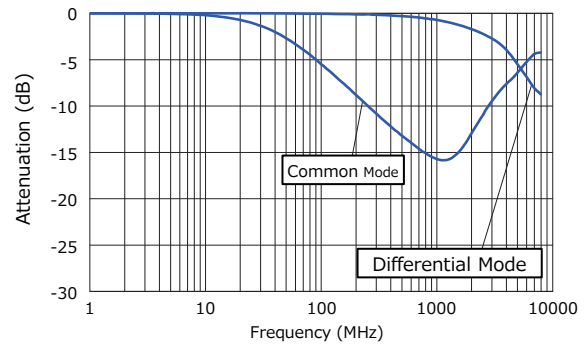

● EXC14CE900U

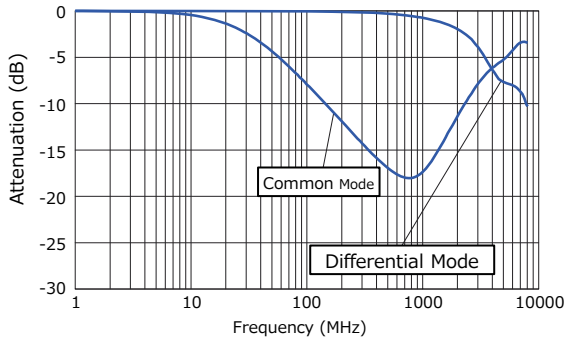

● EXC14CE121U

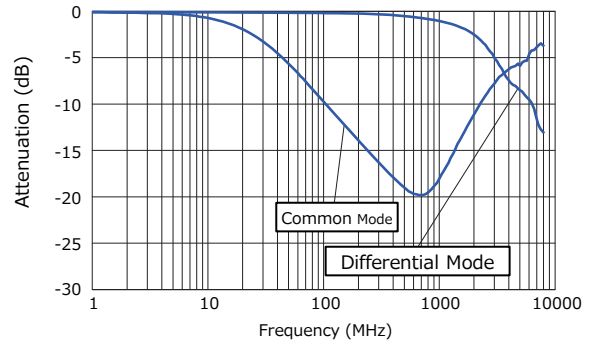

■ As for Packaging Methods, Land Pattern, Soldering Conditions and Safety Precautions, Please see Data Files

Common mode Noise Filters

Type: **EXC14CT**



Features

- Small and thin(L 0.85 mm×W 0.65 mm×H 0.45 mm)
- High attenuation at common-mode for noise suppression of harmonic signal components and cellular frequency
- High cut-off frequency and capability of coping with high-speed signals (USB and HDMI)
- Strong multilayer/sintered structure, excellent reflow resistance and high mounting reliability
- Lead, halogen and antimony-free
- RoHS compliant

Recommended Applications

- Smartphones, Tablet PCs and DSC
- Noise suppression of high-speed differential data lines such as MIPI, USB and LVDS

Explanation of Part Numbers

| | | | | | | | | | | | |
|--------------|------|----------------------------|-------------|---------------------|--------------|-----------------------|--|---|----|------|---|
| 1 | 2 | 3 | 4 | 5 | 6 | 7 | 8 | 9 | 10 | 11 | 12 |
| E | X | C | 1 | 4 | C | T | 9 | 0 | 0 | U | |
| Product Code | | | Size | Number of Terminals | Type | Characteristics | Nominal Impedance | | | Form | Suffix |
| Noise Filter | Code | Dimensions(mm) | 4 Terminals | C | Coupled type | T | The first two digits are significant figure of impedance value, and the third one denotes the number of zeros following. | | | Code | Packing |
| | 1 | 0.85×0.65×.045 (L)×(W)×(H) | | | | High attenuation type | | | | U | Embossed Carrier Taping 2 mm pitch, 10,000 pcs |

Construction

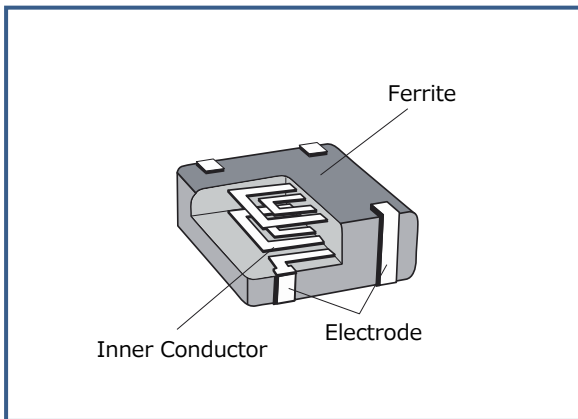

Dimensions in mm (not to scale)

| Part No. (inch size) | Dimensions(mm) | | | | | | Mass (Weight) (mg/ pc.) |
|-------------------------|----------------|---------------|---------------|--------------|---------------|---------------|-------------------------------|
| | A | B | C | D | E | F | |
| EXC14CT (0302) | 0.65 ±0.05 | 0.85 ±0.05 | 0.45 ±0.05 | 0.10 min. | 0.50 ±0.10 | 0.27 ±0.10 | 1.0 |

Circuit Configuration (No Polarity)

※ The pin numbers shown here are for reference purposes only. Confirm the actual pin number arrangement with the exchanged specification documents.

Ratings

| Part Number | Impedance (Ω) at 100 MHz | | Rated Voltage (V) DC | Rated Current (mA) DC | DC Resistance (Ω)max. |
|-------------|-----------------------------------|-------------------|----------------------|-----------------------|--------------------------------|
| | Common Mode | Differential Mode | | | |
| EXC14CT500U | 50 Ω ±25 % | 17 Ω max. | 5 | 100 | 2.3 Ω ±30 % |
| EXC14CT900U | 90 Ω ±20 % | 20 Ω max. | 5 | 100 | 3.3 Ω ±30 % |

● Category Temperature Range -40 °C to +85 °C

Impedance Characteristics (Typical)

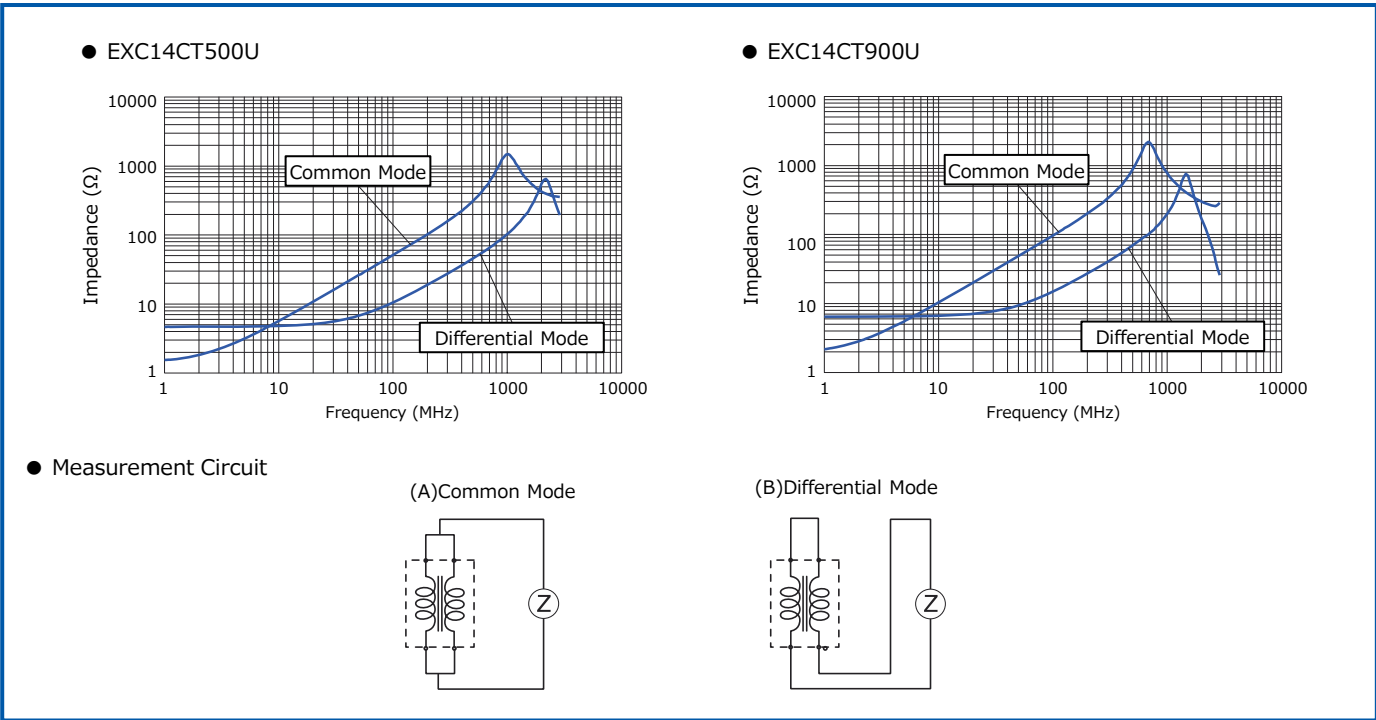

Attenuation Characteristics (Typical)

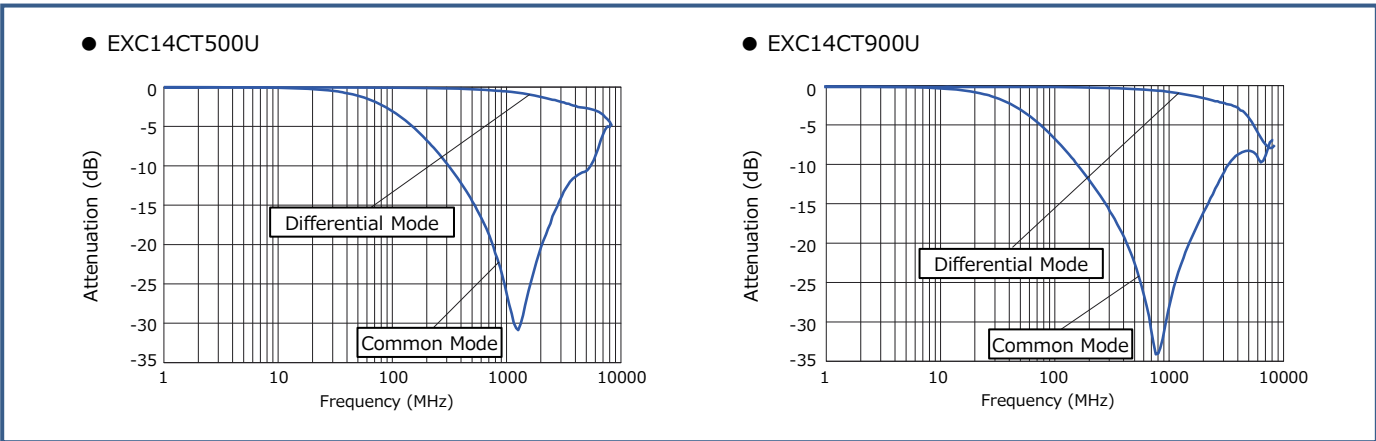

■ As for Packaging Methods, Land Pattern, Soldering Conditions and Safety Precautions, Please see Data Files

Common mode Noise Filters

Type: **EXC14CX**



Features

- Small and thin (L 0.85 mm×W 0.65 mm×H 0.45 mm)
- Effective noise suppression of smartphones by eliminating common mode noises and removing differential signal components
- Strong multilayer/sintered structure, excellent reflow resistance and high mounting reliability
- Lead, halogen and antimony-free
- RoHS compliant

Recommended Applications

- Smartphones, Tablet PCs and DSC
- Noise suppression of high-speed differential data lines such as MIPI, USB and LVDS

Explanation of Part Numbers

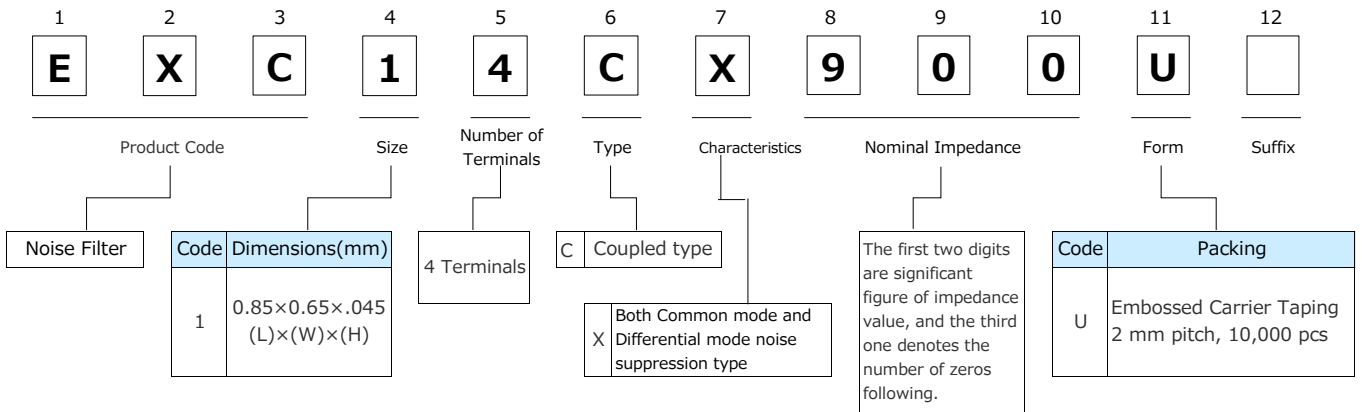

Construction

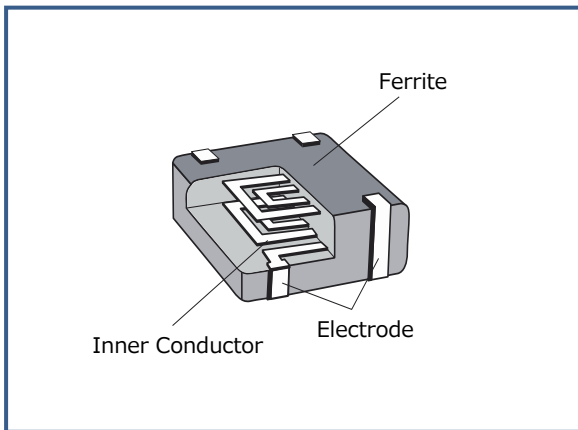

Dimensions in mm (not to scale)

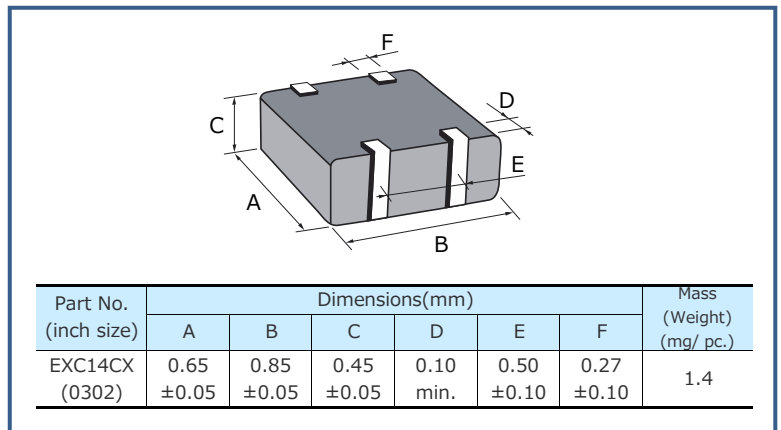

Circuit Configuration (No Polarity)

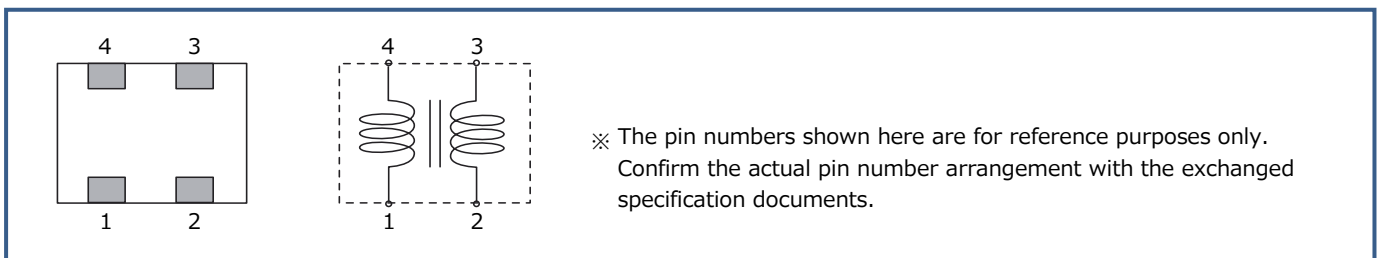

| Ratings | | | | | |
|-------------|-----------------------------------|-------------------|----------------------|-----------------------|--------------------------------|
| Part Number | Impedance (Ω) at 100 MHz | | Rated Voltage (V) DC | Rated Current (mA) DC | DC Resistance (Ω)max. |
| | Common Mode | Differential Mode | | | |
| EXC14CX280U | 28 Ω ±25 % | 25 Ω max. | 5 | 100 | 3.0 |
| EXC14CX400U | 40 Ω ±25 % | 30 Ω max. | 5 | 100 | 4.0 |

● Category Temperature Range -40 °C to +85 °C

Impedance Characteristics (Typical)

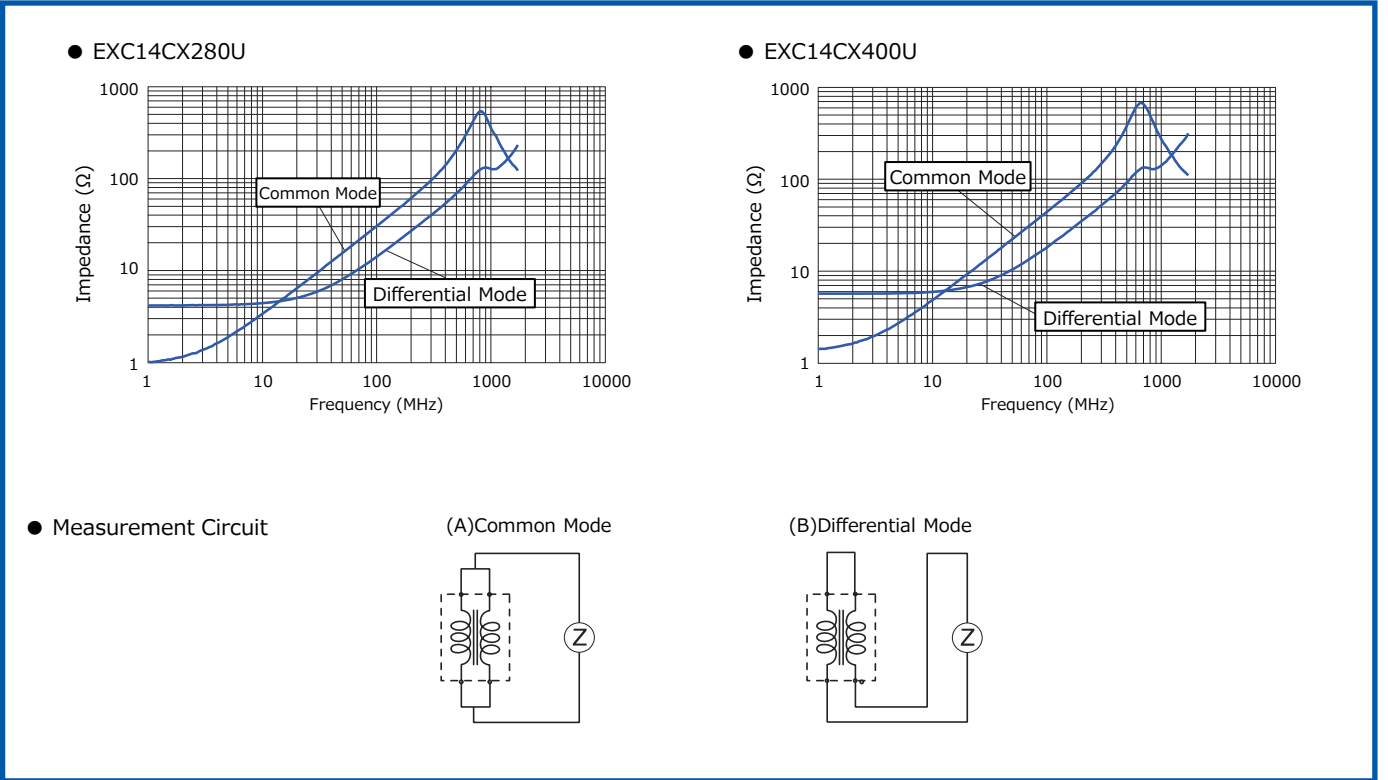

Attenuation Characteristics (Typical)

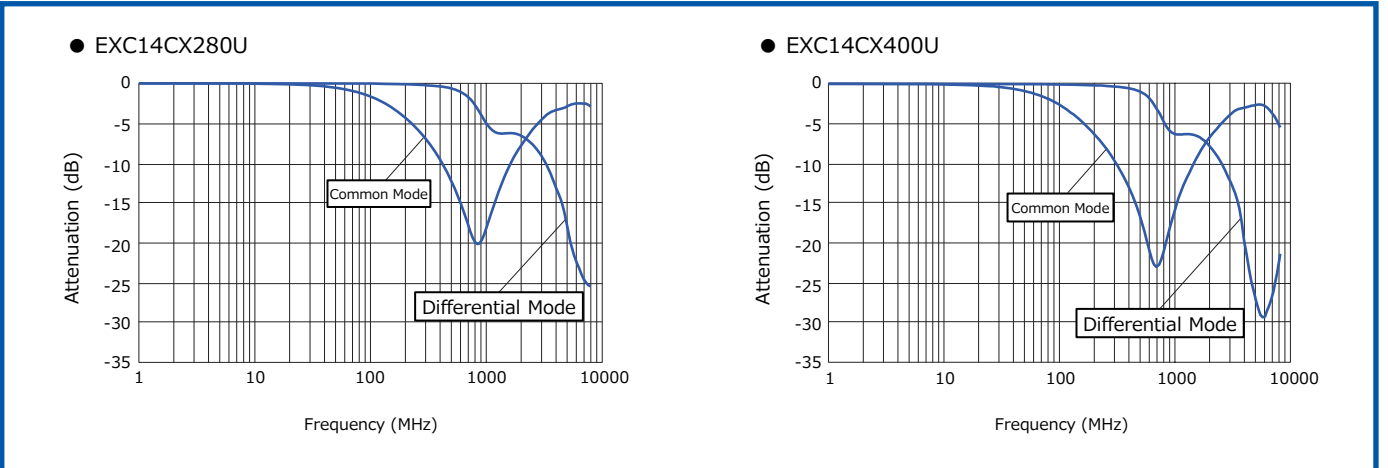

■ As for Packaging Methods, Land Pattern, Soldering Conditions and Safety Precautions, Please see Data Files

Common mode Noise Filters

Type: **EXC16CT**



Features

- Corresponding to new high-speed differential interface (MIPI C-PHY)
Corresponding to 3-line transmission, transmission rate up to 2.5 Gbps
- Unique plating fine coil process and ceramic multilayer process enable compact size
(L 0.90 × W 0.68 × H 0.40 mm)
around 40% reduction of mounting area (comparing with MIPI D-PHY)
- Strong multilayer/sintered structure, excellent reflow resistance and high mounting reliability
- Lead, halogen and antimony-free
- RoHS compliant

Recommended Applications

- High resolution camera and display equipped mobile devices (Smartphones, Tablet PCs and wearable)
- Noise suppression of high-speed differential data lines such as MIPI C-PHY

Explanation of Part Numbers

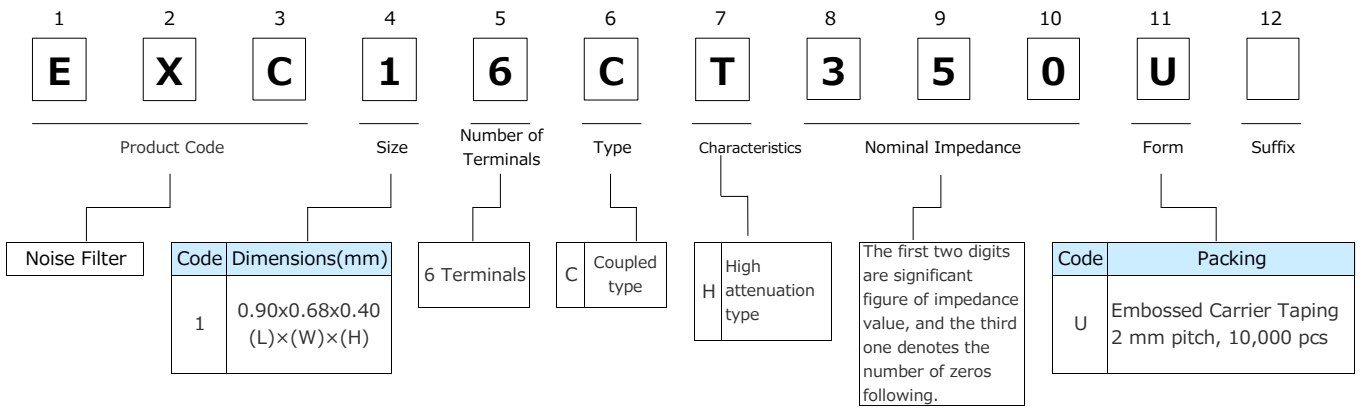

Construction

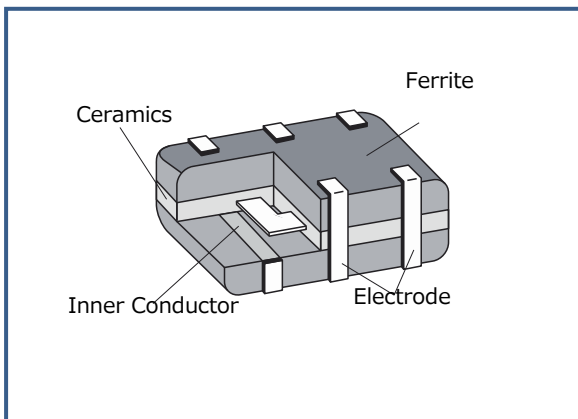

Dimensions in mm (not to scale)

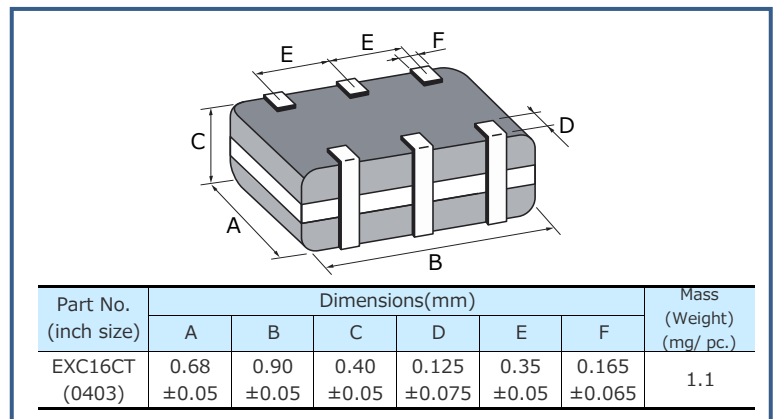

Circuit Configuration (No Polarity)

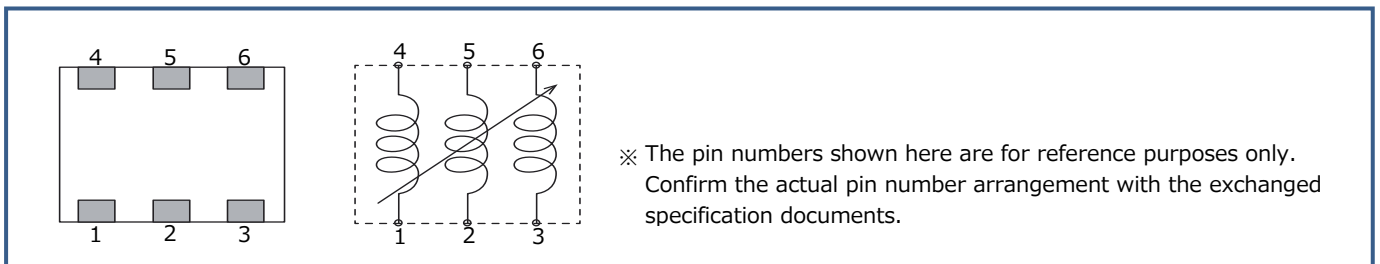

Ratings

| Part Number | Impedance (Ω) at 100 MHz | Rated Voltage (V) DC | Rated Current (mA) DC | DC Resistance (Ω)max. |
|-------------|-----------------------------------|----------------------|-----------------------|--------------------------------|
| | Common Mode | | | |
| EXC16CT250U | 25 $\Omega \pm 25\%$ | 5 | 100 | 3.0 |
| EXC16CT350U | 35 $\Omega \pm 30\%$ | 5 | 100 | 4.0 |

● Category Temperature Range $-40\text{ }^{\circ}\text{C}$ to $+85\text{ }^{\circ}\text{C}$

Common mode Impedance Characteristics (Typical)

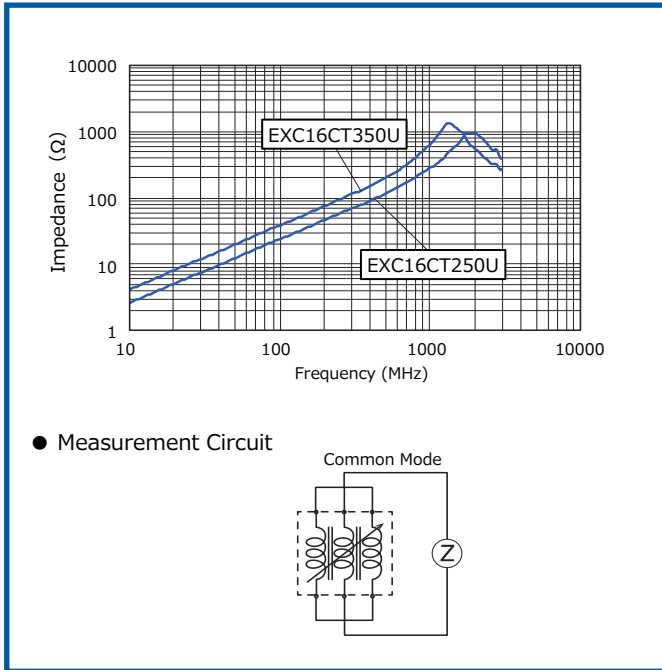

Common mode Attenuation Characteristics (Typical)

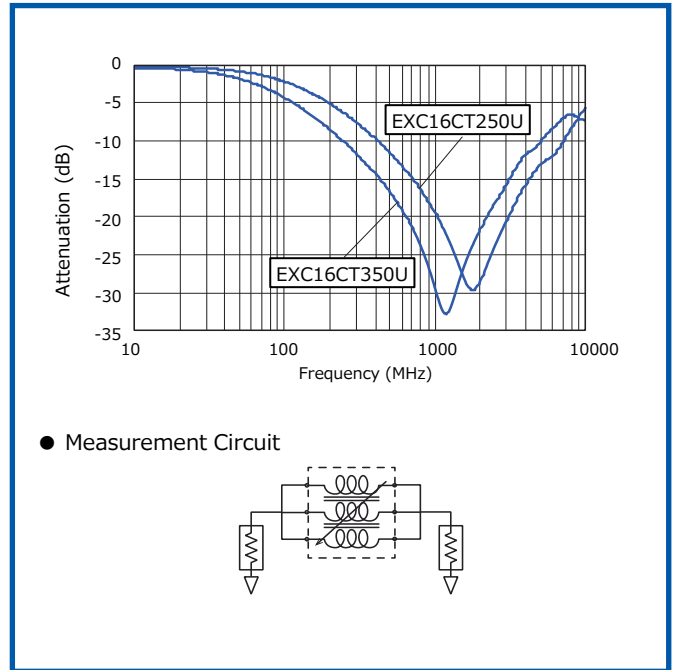

Differential Insertion Loss (Typical)

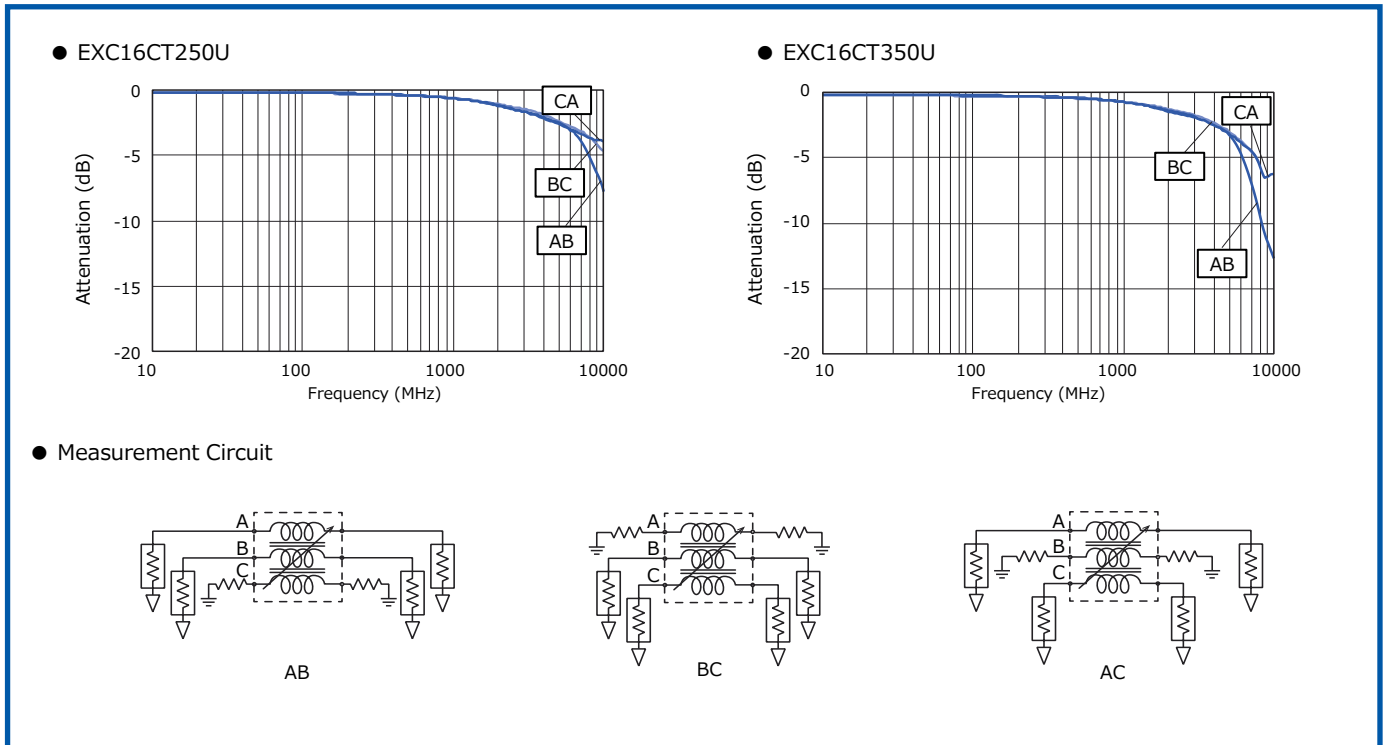

■ As for Packaging Methods, Land Pattern, Soldering Conditions and Safety Precautions, Please see Data Files

Common mode Noise Filters

Type: **EXC24CH**



Features

- Small and thin type, built-in filter circuit (L 1.25 mm×W 1.00 mm×H 0.50 mm)
- Suppression of high frequency noise with little influence of waveform rounding on signal transmission, achieved by setting high cut-off frequency between 6 and 10 GHz
- Strong multilayer/sintered structure, excellent reflow resistance and high mounting reliability
- Lead, halogen and antimony-free
- RoHS compliant

Recommended Applications

- AV equipment (LCD-TV, DVD/Blu-ray drives), Information equipment (PCs, HDD), Communications equipment (Mobile phones, Smartphones)
- Noise suppression of high-speed differential data lines such as USB 3.0, HDMI and Display Port

Explanation of Part Numbers

| | | | | | | | | | | | |
|--------------|----------|----------------------------|-------------|---------------------|---|--|-------------------|----------|----------|--|--------|
| 1 | 2 | 3 | 4 | 5 | 6 | 7 | 8 | 9 | 10 | 11 | 12 |
| E | X | C | 2 | 4 | C | H | 9 | 0 | 0 | U | |
| Product Code | | | Size | Number of Terminals | Type | Characteristics | Nominal Impedance | | | Form | Suffix |
| Noise Filter | Code | Dimensions(mm) | 4 Terminals | C | Coupled type | The first two digits are significant figure of impedance value, and the third one denotes the number of zeros following. | | | Code | Packing | |
| | 2 | 1.25×1.00×0.50 (L)×(W)×(H) | | H | High speed Differential transmission (for Gbps) | | | | U | Embossed Carrier Taping 4 mm pitch, 5,000 pcs | |

Construction

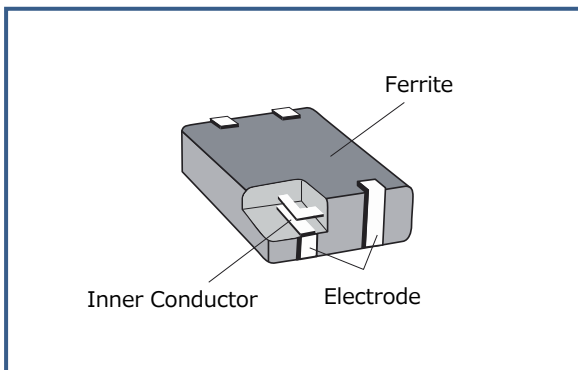

Dimensions in mm (not to scale)

| Part No. (inch size) | Dimensions(mm) | | | | | | Mass (Weight) (mg/ pc.) |
|-------------------------|----------------|---------------|---------------|---------------|---------------|---------------|-------------------------------|
| | A | B | C | D | E | F | |
| EXC24CH (0504) | 1.25 ±0.15 | 1.00 ±0.15 | 0.50 ±0.10 | 0.20 ±0.15 | 0.55 ±0.10 | 0.30 ±0.10 | 3 |

Circuit Configuration (No Polarity)

※ The pin numbers shown here are for reference purposes only. Confirm the actual pin number arrangement with the exchanged specification documents.

| Ratings | | | | | | |
|-------------|-----------------------------------|-------------------|------------------------|----------------------|-----------------------|--------------------------------|
| Part Number | Impedance (Ω) at 100 MHz | | Cutoff Frequency (GHz) | Rated Voltage (V) DC | Rated Current (mA) DC | DC Resistance (Ω)max. |
| | Common Mode | Differential Mode | | | | |
| EXC24CH500U | 50 Ω ±25 % | 13 Ω max. | 10 Typ. | 5 | 160 | 1.5 |
| EXC24CH900U | 90 Ω ±20 % | 15 Ω max. | 6 Typ. | 5 | 130 | 2.5 |

● Category Temperature Range -40 °C to +85 °C

Impedance Characteristics (Typical)

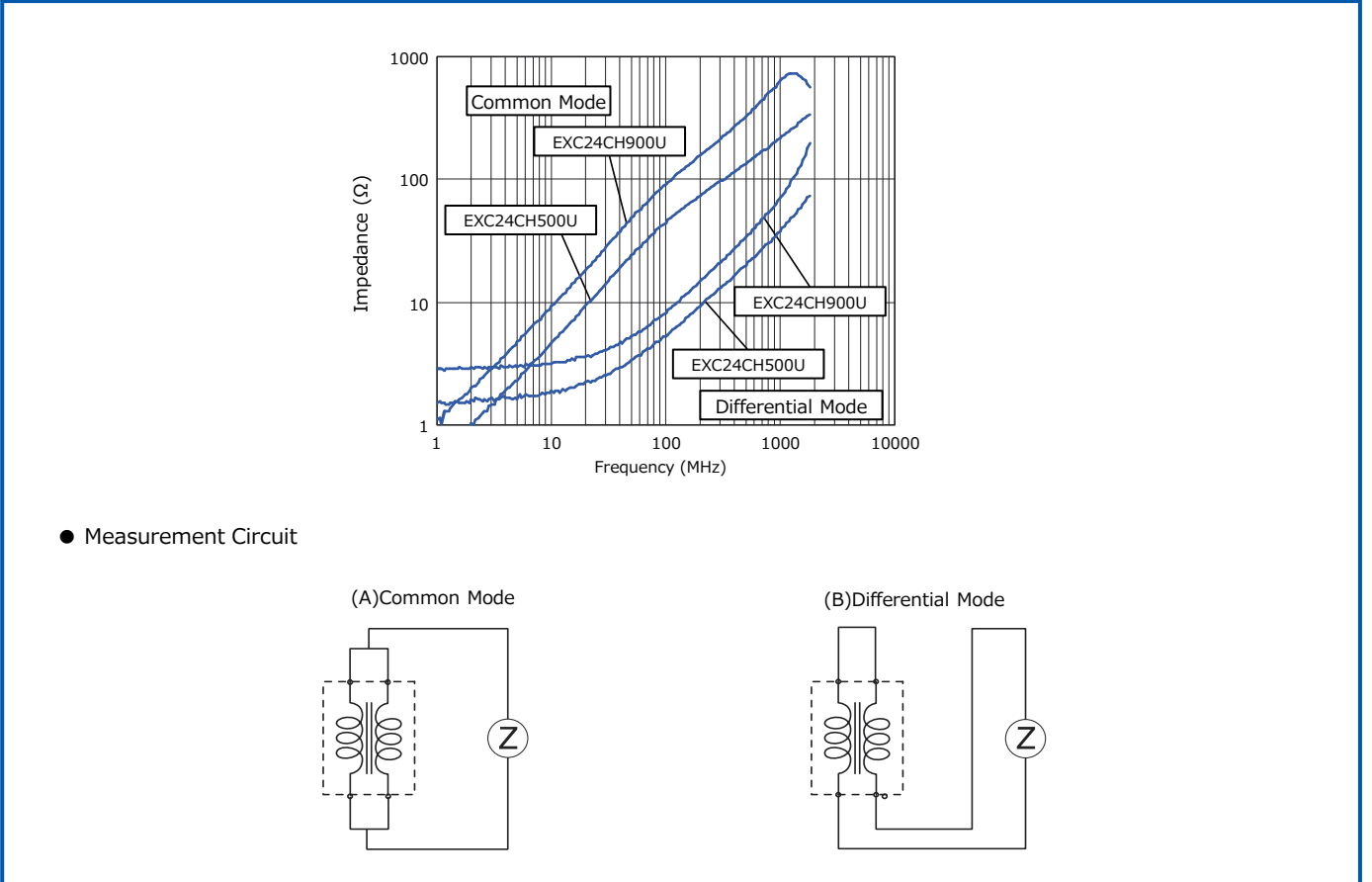

● Measurement Circuit

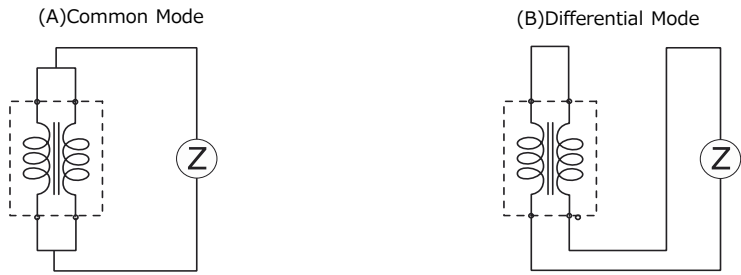

Insertion Loss (Typical)

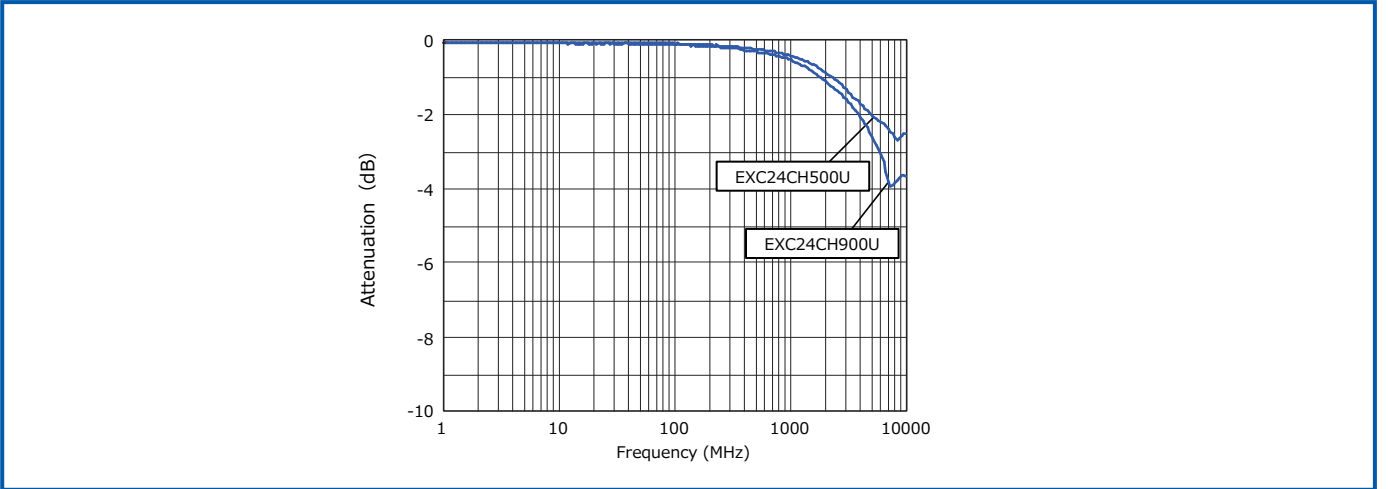

■ As for Packaging Methods, Land Pattern, Soldering Conditions and Safety Precautions, Please see Data Files

Common mode Noise Filters

Type: **EXC24CG**



Features

- Elimination of radiation noises from high-speed differential transmissions
- Prevention of reflection of transmission signals and noise radiation by controlling TDR characteristic impedance as 100 Ω
- Satisfaction of eye pattern standards of HDMI waveforms with capability to improve waveform fluctuations of skew and overshoot
- Simple multilayer structure, excellent mass productivity and high reliability
- Small and thin (L 1.25 mm×W 1.00 mm×H 0.50 mm)
- RoHS compliant

Recommended Applications

- AV equipment (LCD-TV, DVD/Blu-ray drives), Information equipment (PCs, HDD), Communications equipment (Mobile phones, Smartphones)
- Noise suppression of high-speed differential data lines such as HDMI, SATA and LAN

Explanation of Part Numbers

| | | | | | | | | | | | |
|--------------|----------|----------|----------------------------|---------------------|----------------|---|--|----------|----------|--|--------|
| 1 | 2 | 3 | 4 | 5 | 6 | 7 | 8 | 9 | 10 | 11 | 12 |
| E | X | C | 2 | 4 | C | G | 9 | 0 | 0 | U | |
| Product Code | | Size | | Number of Terminals | Type | Characteristics | Nominal Impedance | | Form | | Suffix |
| Noise Filter | | Code | Dimensions(mm) | 4 Terminals | C Coupled type | G High speed Differential transmission (for Gbps) | The first two digits are significant figure of impedance value, and the third one denotes the number of zeros following. | | Code | Packing | |
| | | 2 | 1.25×1.00×0.50 (L)×(W)×(H) | | | | | | U | Embossed Carrier Taping 4 mm pitch, 5,000 pcs | |

Construction

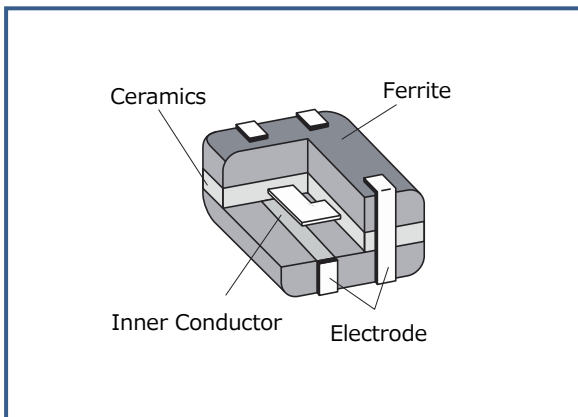

Dimensions in mm (not to scale)

| Part No. (inch size) | Dimensions(mm) | | | | | | Mass (Weight) (mg/ pc.) |
|-------------------------|----------------|---------------|---------------|---------------|---------------|---------------|-------------------------------|
| | A | B | C | D | E | F | |
| EXC24CG (0504) | 1.25 ±0.15 | 1.00 ±0.15 | 0.50 ±0.10 | 0.20 ±0.15 | 0.55 ±0.10 | 0.30 ±0.10 | 3 |

Circuit Configuration (No Polarity)

※ The pin numbers shown here are for reference purposes only. Confirm the actual pin number arrangement with the exchanged specification documents.

| Ratings | | | | | |
|-------------|-----------------------------------|-------------------|----------------------|-----------------------|--------------------------------|
| Part Number | Impedance (Ω) at 100 MHz | | Rated Voltage (V) DC | Rated Current (mA) DC | DC Resistance (Ω)max. |
| | Common Mode | Differential Mode | | | |
| EXC24CG240U | 24 Ω ±25 % | 15 Ω max. | 5 | 160 | 1.5 |
| EXC24CG360U | 36 Ω ±25 % | 15 Ω max. | 5 | 130 | 1.7 |
| EXC24CG900U | 90 Ω ±25 % | 20 Ω max. | 5 | 100 | 3.0 |

● Category Temperature Range -40 °C to +85 °C

Impedance Characteristics (Typical)

● EXC24CG240U

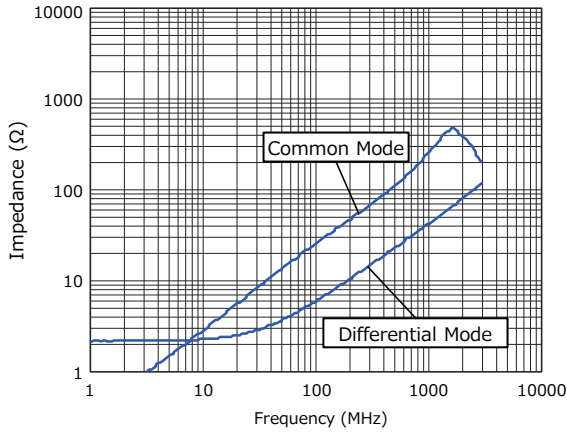

● EXC24CG360U

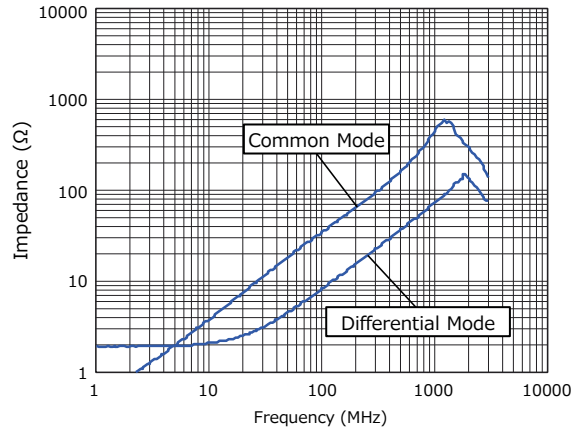

● EXC24CG900U

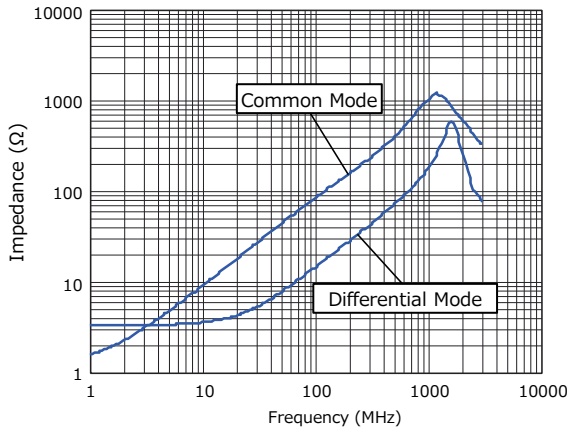

● Measurement Circuit

(A) Common Mode

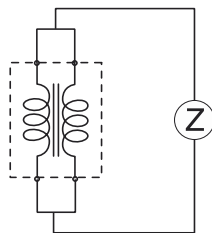

(B) Differential Mode

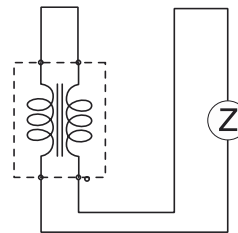

■ As for Packaging Methods, Land Pattern, Soldering Conditions and Safety Precautions, Please see Data Files

Common mode Noise Filters

Type: **EXC24CE/EXC24CF**



Features

- Elimination of radiation noises from high-speed differential transmissions
- Strong multilayer structure, excellent reflow resistance and high mounting reliability
- Magnetic shield type with no leakage
- High-Q impedance : EXC24CF
- Small and thin (L 1.25 mm×W 1.00 mm×H 0.50 mm)
- RoHS compliant

Recommended Applications

- AV equipment (LCD-TV, DVD/Blu-ray drives), Information equipment (PCs, HDD, Printers), Communications equipment (Mobile phones, Smartphones)
- Noise suppression of high-speed differential data lines such as USB 2.0 and LVDS

Explanation of Part Numbers

| | | | | | | | | | | | |
|--------------|----------|----------|----------------------------|---------------------|----------------|--|--|----------|----------|----------|--|
| 1 | 2 | 3 | 4 | 5 | 6 | 7 | 8 | 9 | 10 | 11 | 12 |
| E | X | C | 2 | 4 | C | E | 9 | 0 | 0 | U | |
| Product Code | | Size | | Number of Terminals | Type | Characteristics | Nominal Impedance | | | Form | Suffix |
| Noise Filter | | Code | Dimensions(mm) | 4 Terminals | C Coupled type | E High speed Differential transmission (for Mbps) F High speed Differential transmission (for Mbps) High-Q type | The first two digits are significant figure of impedance value, and the third one denotes the number of zeros following. | | | Code | Packing |
| | | 2 | 1.25×1.00×0.50 (L)×(W)×(H) | | | | | | | U | Embossed Carrier Taping 4 mm pitch, 5,000 pcs |

Construction

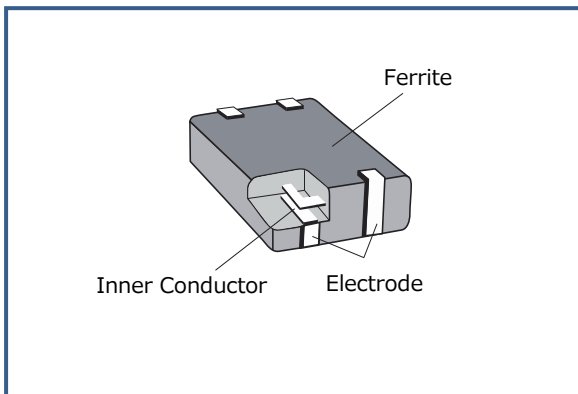

Dimensions in mm (not to scale)

| Part No. (inch size) | Dimensions(mm) | | | | | | Mass (Weight) (mg/ pc.) |
|-------------------------|----------------|-------|-------|-------|-------|-------|-------------------------------|
| | A | B | C | D | E | F | |
| EXC24CE | 1.25 | 1.00 | 0.50 | 0.20 | 0.55 | 0.30 | 3 |
| EXC24CF (0504) | ±0.15 | ±0.15 | ±0.10 | ±0.15 | ±0.10 | ±0.10 | |

Circuit Configuration (No Polarity)

※ The pin numbers shown here are for reference purposes only. Confirm the actual pin number arrangement with the exchanged specification documents.

| Ratings | | | | | |
|--------------|-----------------------------------|-------------------|----------------------|-----------------------|--------------------------------|
| Part Number | Impedance (Ω) at 100 MHz | | Rated Voltage (V) DC | Rated Current (mA) DC | DC Resistance (Ω)max. |
| | Common Mode | Differential Mode | | | |
| EXC24CE360UP | 36 Ω ±25 % | 20 Ω max. | 5 | 200 | 1.0 |
| EXC24CE900U | 90 Ω ±25 % | 15 Ω max. | 5 | 160 | 1.75 |
| EXC24CE121U | 120 Ω ±25 % | 18 Ω max. | 5 | 140 | 2.2 |
| EXC24CE201U | 200 Ω ±25 % | 20 Ω max. | 5 | 130 | 2.7 |
| EXC24CF900U | 90 Ω ±25 % | 20 Ω max. | 5 | 130 | 2.5 |

● Category Temperature Range -40 °C to +85 °C

Impedance Characteristics (Typical)

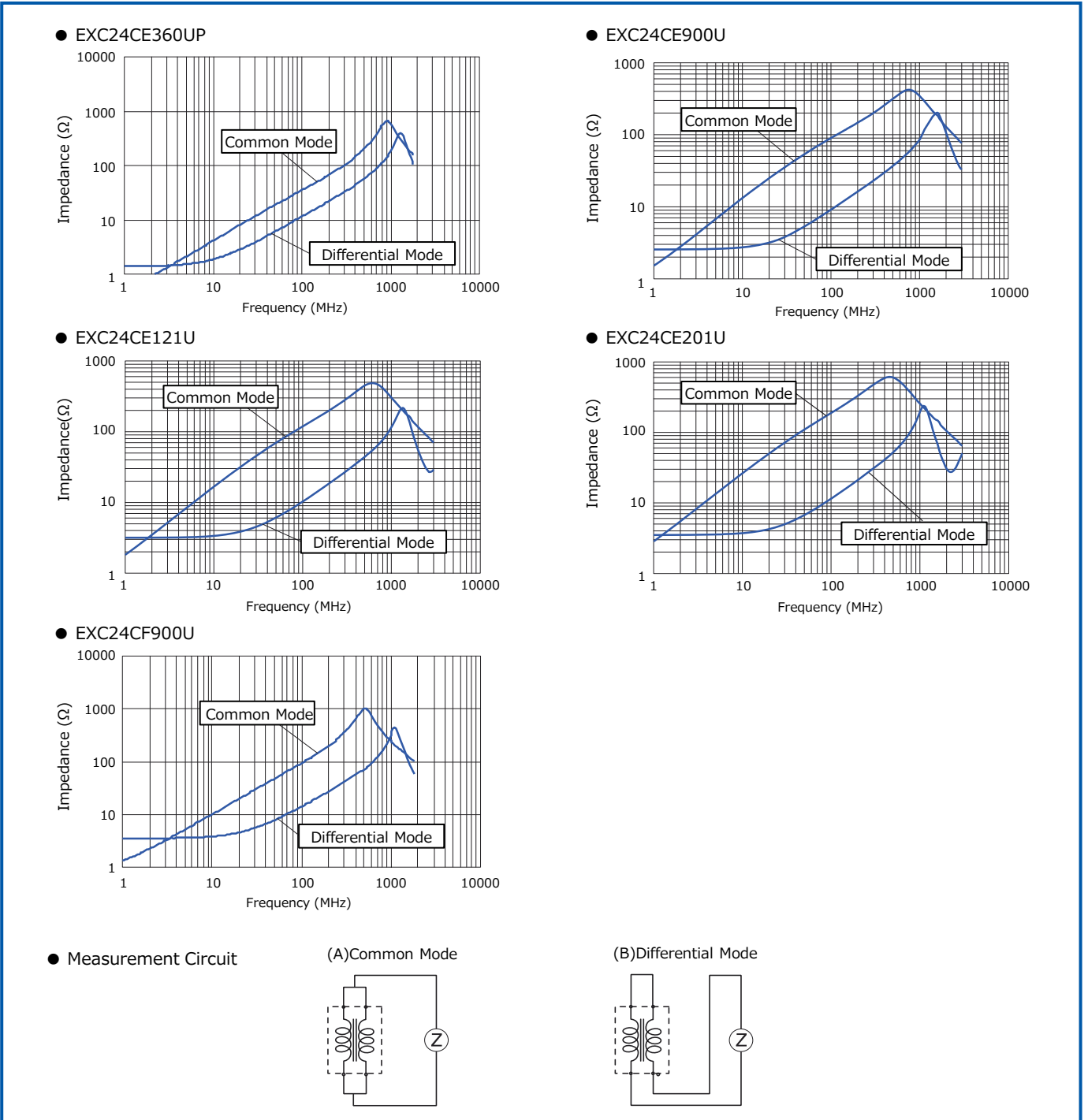

■ As for Packaging Methods, Land Pattern, Soldering Conditions and Safety Precautions, Please see Data Files

Common mode Noise Filters

Type: **EXC34CG/CE**



Features

- Thin type, built-in filter circuit (L 2.0 mm×W 1.25 mm×H 0.50 mm)
- Noise suppression of high-speed differential transmission lines with little influence of waveform rounding on signal transmission
- Strong multilayer/sintered structure, excellent reflow resistance and high mounting reliability
- Lead, halogen and antimony-free
- RoHS compliant

Recommended Applications

- AV equipment (LCD-TV, DVD/Blu-ray drives), Information equipment (PCs, HDD, Printers)
- Noise suppression of high-speed differential data lines such as USB2.0, LVDS, HDMI and LAN

Explanation of Part Numbers

| | | | | | | | | | | | |
|--------------|----------|----------------------------|----------|---------------------|----------------|--|--|----------|----------|----------|--|
| 1 | 2 | 3 | 4 | 5 | 6 | 7 | 8 | 9 | 10 | 11 | 12 |
| E | X | C | 3 | 4 | C | G | 9 | 0 | 0 | U | |
| Product Code | | Size | | Number of Terminals | Type | Characteristics | Nominal Impedance | | | Form | Suffix |
| Noise Filter | Code | Dimensions(mm) | | 4 Terminals | C Coupled type | E High speed Differential transmission (for Mbps) G High speed Differential transmission (for Gbps) | The first two digits are significant figure of impedance value, and the third one denotes the number of zeros following. | | | Code | Packing |
| | 3 | 2.00×1.25×0.50 (L)×(W)×(H) | | | | | | | | U | Embossed Carrier Taping 4 mm pitch, 5,000 pcs |

Construction

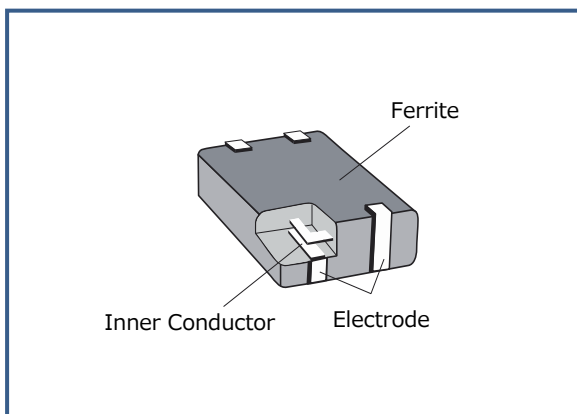

Dimensions in mm (not to scale)

| Part No. (inch size) | Dimensions(mm) | | | | | | Mass (Weight) (mg/ pc.) |
|-------------------------|----------------|---------------|---------------|---------------|---------------|---------------|-------------------------------|
| | A | B | C | D | E | F | |
| EXC34C (0805) | 2.00 ±0.15 | 1.25 ±0.15 | 0.50 ±0.10 | 0.30 ±0.20 | 0.80 ±0.10 | 0.30 ±0.15 | 5 |

Circuit Configuration (No Polarity)

※ The pin numbers shown here are for reference purposes only. Confirm the actual pin number arrangement with the exchanged specification documents.

Ratings

| Part Number | Impedance (Ω) at 100 MHz | Rated Current (mA) DC | Rated Voltage (V) DC | Insulation Resistance (M Ω)min. | Withstand Voltage (V) DC | DC Resistance (Ω)max. |
|-------------|-----------------------------------|-----------------------|----------------------|---|--------------------------|--------------------------------|
| | Common Mode | | | | | |
| EXC34CE670U | 67 Ω ±25 % | 250 | 5 | 10 M Ω | 125 | 0.8 |
| EXC34CE900U | 90 Ω ±25 % | 250 | 5 | 10 M Ω | 125 | 0.8 |
| EXC34CE121U | 120 Ω ±25 % | 200 | 5 | 10 M Ω | 125 | 1.0 |
| EXC34CE201U | 200 Ω ±25 % | 200 | 5 | 10 M Ω | 125 | 1.0 |
| EXC34CG900U | 90 Ω ±25 % | 100 | 5 | 10 M Ω | 125 | 3.0 |

● Category Temperature Range -40 °C to +85 °C

Impedance Characteristics (Typical)

● EXC34CE670U

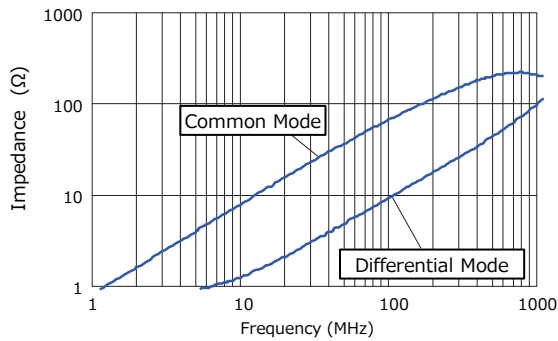

● EXC34CE900U

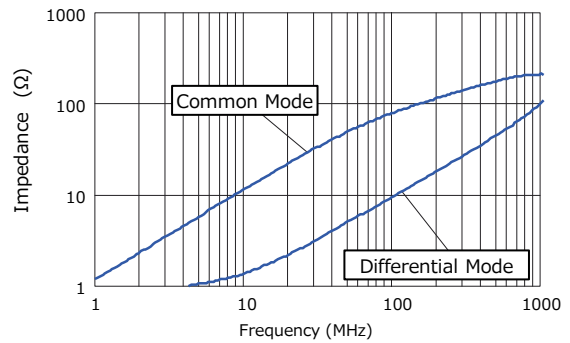

● EXC34CE121U

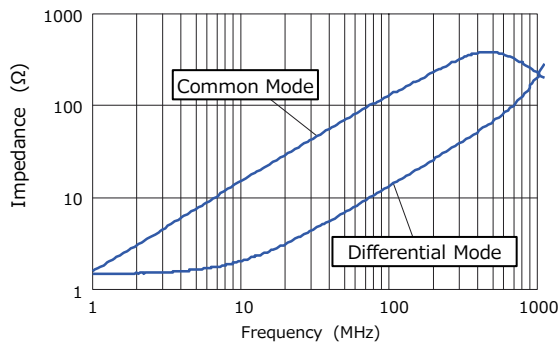

● EXC34CE201U

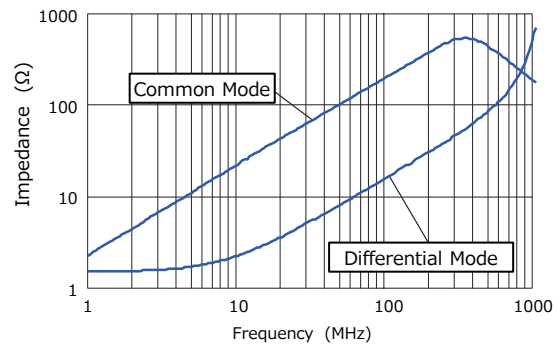

● EXC34CG900U

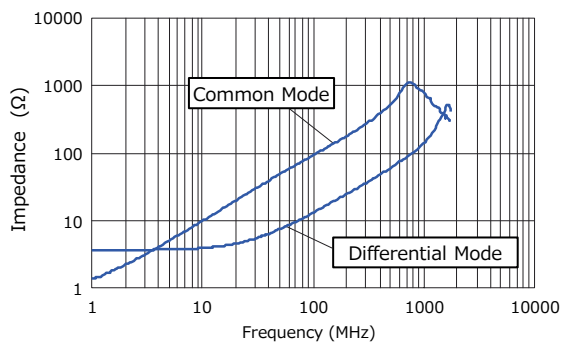

● Measurement Circuit

(A) Common Mode

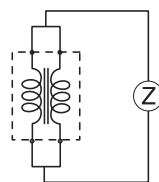

(B) Differential Mode

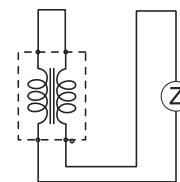

■ As for Packaging Methods, Land Pattern, Soldering Conditions and Safety Precautions, Please see Data Files

Common mode Noise Filters Array

Type: **EXC18CG/EXC18CE**



Features

- Small and thin type, two built-in filter circuit (L 1.6 mm ×W 0.8 mm×H 0.4 mm)
- Noise suppression of high-speed differential transmission lines with little influence of waveform rounding on signal transmission
- Low DC resistance and low insertion loss
- High-Q value and high impedance of GHz zone : EXC18CG type
- Strong multilayer/sintered structure, excellent reflow resistance and high mounting reliability
- Lead, halogen and antimony-free
- RoHS compliant

Recommended Applications

- AV equipment (LCD-TV, DVD/Blu-ray drives), Information equipment (PCs, HDD, Printers)
- Noise suppression of high-speed differential data lines such as USB2.0, LVDS, HDMI and LAN

Explanation of Part Numbers

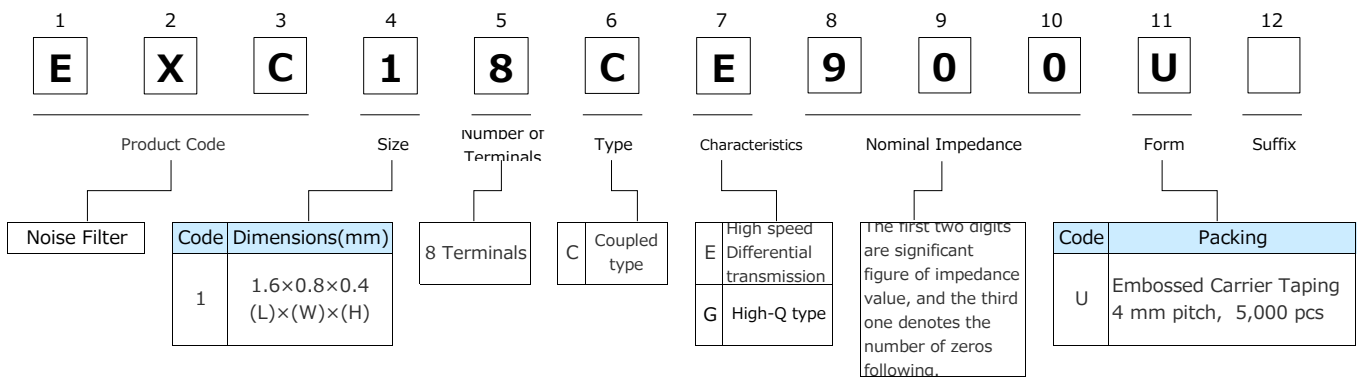

Construction

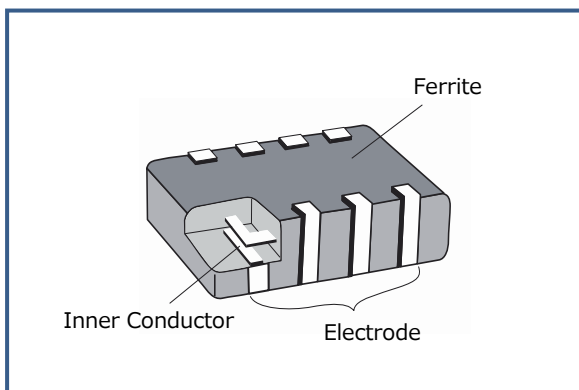

Dimensions in mm (not to scale)

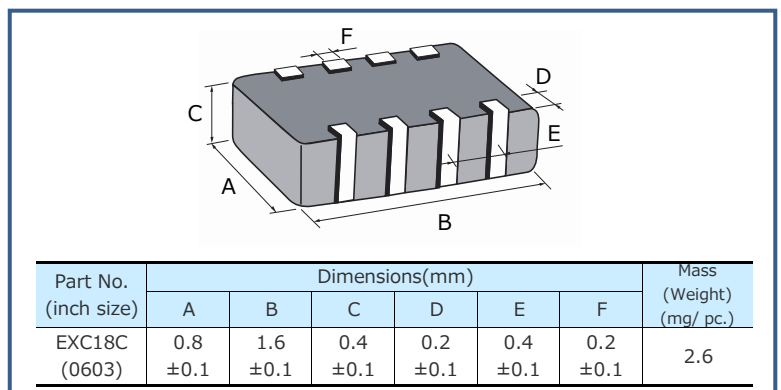

Circuit Configuration (No Polarity)

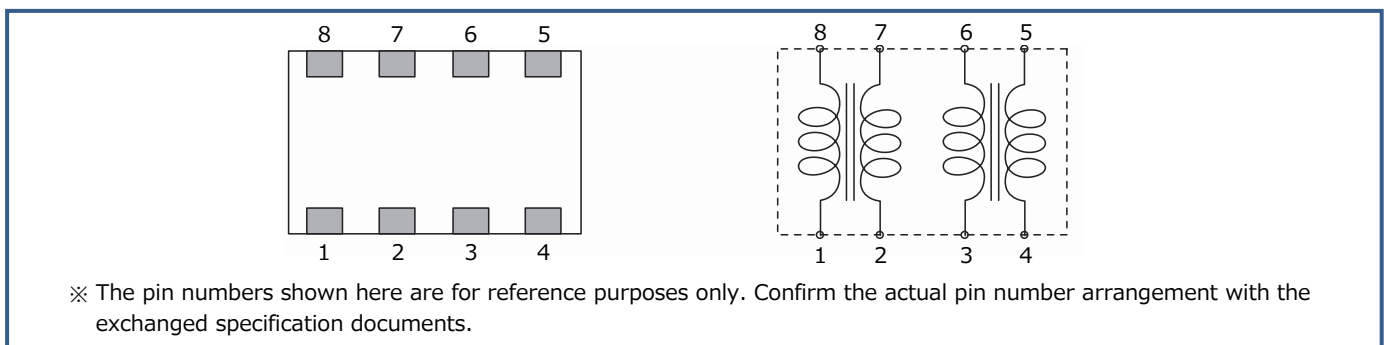

| Ratings | | | | | |
|-------------|-----------------------------------|-------------------|----------------------|-----------------------|--------------------------------|
| Part Number | Impedance (Ω) at 100 MHz | | Rated Voltage (V) DC | Rated Current (mA) DC | DC Resistance (Ω)max. |
| | Common Mode | Differential Mode | | | |
| EXC18CG430U | 43 Ω ±25 % | 15 Ω max. | 5 | 100 | 2.7 |
| EXC18CE650U | 65 Ω ±20 % | 18 Ω max. | 5 | 140 | 1.8 |
| EXC18CE900U | 90 Ω ±20 % | 20 Ω max. | 5 | 130 | 2.0 |
| EXC18CE201U | 200 Ω ±20 % | 22 Ω max. | 5 | 100 | 3.5 |

● Category Temperature Range -40 °C to +85 °C

Impedance Characteristics (Typical)

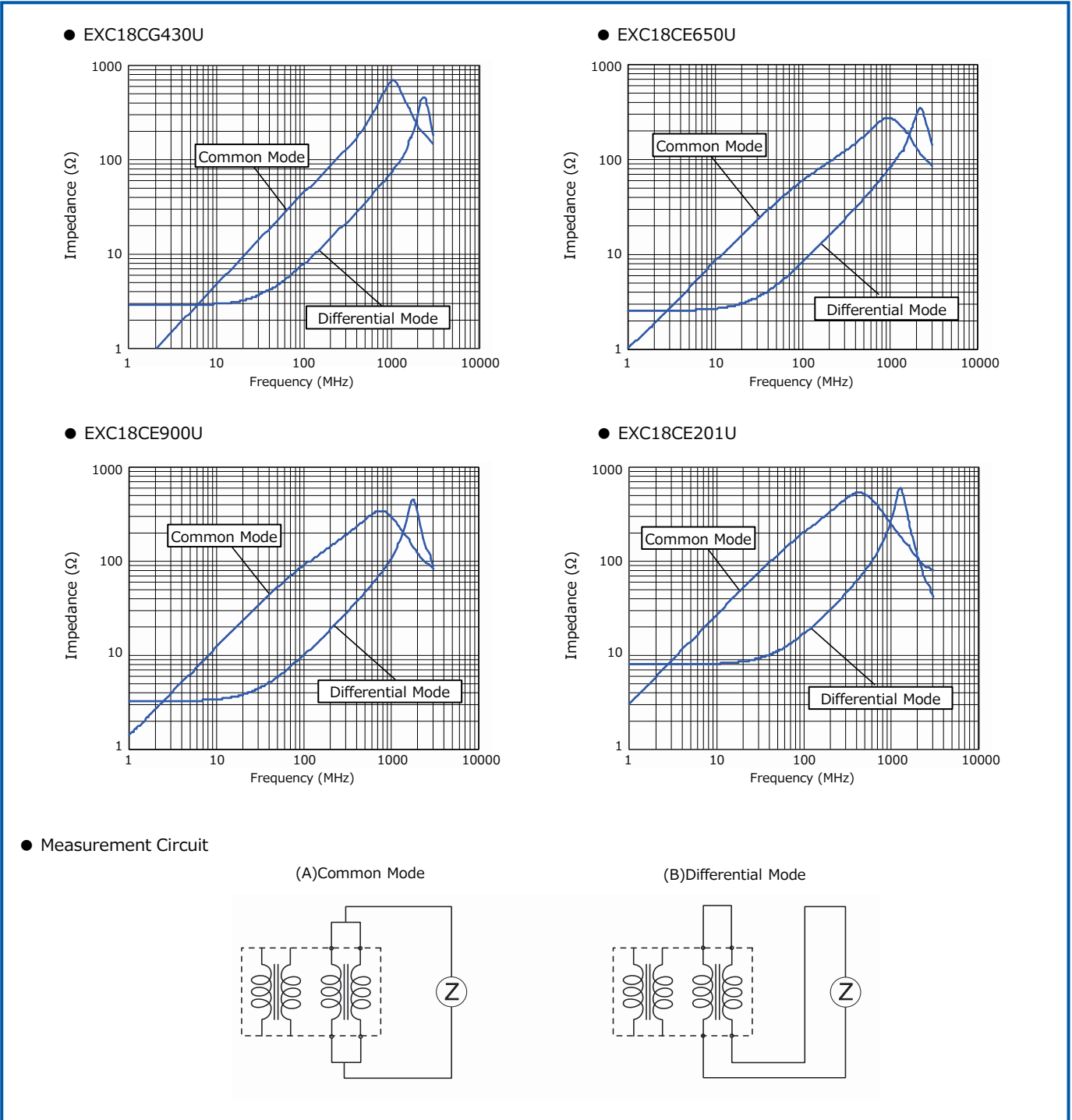

■ As for Packaging Methods, Land Pattern, Soldering Conditions and Safety Precautions, Please see Data Files

Common mode Noise Filters Array

Type: **EXC28CH**



Features

- Small and thin type, two built-in filter circuit (L 2.0 mm×W 1.0 mm×H 0.5 mm)
- Suppression of high frequency noise with little influence of waveform rounding on signal transmission, achieved by setting high cut-off frequency between 6 and 10 GHz
- Strong multilayer/sintered structure, excellent reflow resistance and high mounting reliability
- Lead, halogen and antimony-free
- RoHS compliant

Recommended Applications

- AV equipment (LCD-TV, DVD/Blu-ray drives), Information equipment (PCs, HDD, Printers)
- Noise suppression of high-speed differential data lines such as USB3.0, LVDS, HDMI and LAN

Explanation of Part Numbers

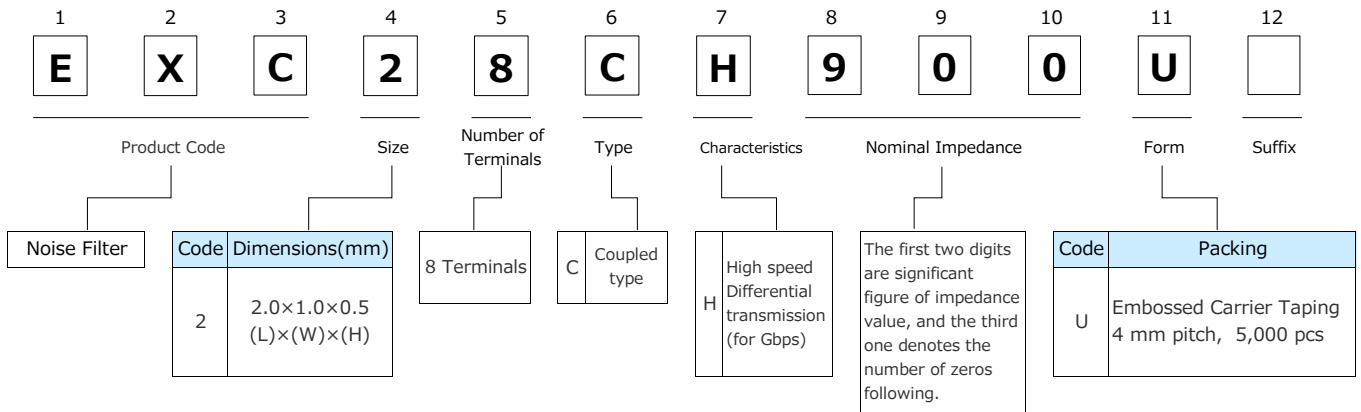

Construction

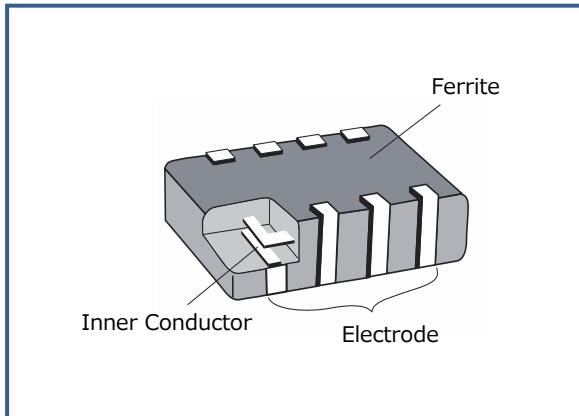

Dimensions in mm (not to scale)

| Part No. (inch size) | Dimensions(mm) | | | | | | Mass (Weight) (mg/ pc.) |
|-------------------------|----------------|-------------|-------------|---------------|-------------|---------------|-------------------------------|
| | A | B | C | D | E | F | |
| EXC28CH (0804) | 1.00 ±0.15 | 2.0 ±0.2 | 0.5 ±0.1 | 0.20 ±0.15 | 0.5 ±0.1 | 0.25 ±0.10 | 5 |

Circuit Configuration (No Polarity)

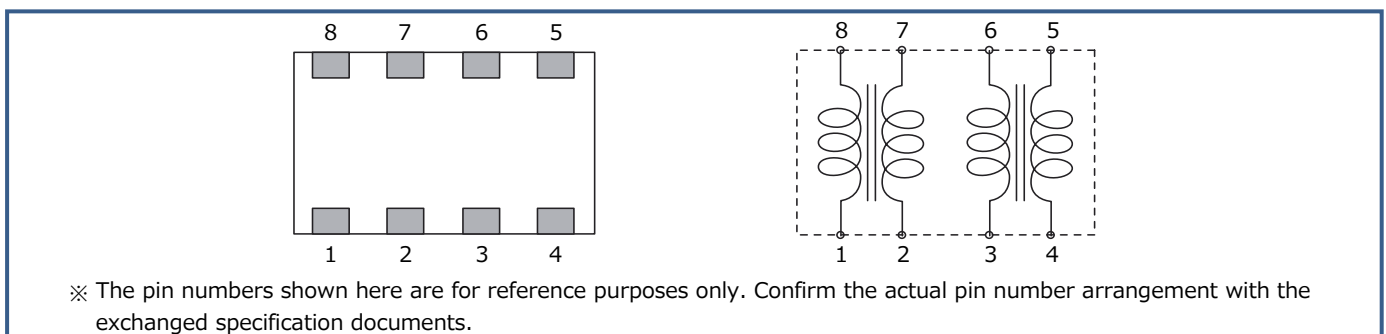

| Ratings | | | | | | |
|-------------|-----------------------------------|-------------------|------------------------|----------------------|-----------------------|--------------------------------|
| Part Number | Impedance (Ω) at 100 MHz | | Cutoff Frequency (GHz) | Rated Voltage (V) DC | Rated Current (mA) DC | DC Resistance (Ω)max. |
| | Common Mode | Differential Mode | | | | |
| EXC28CH500U | 50 Ω ±25 % | 13 Ω max. | 10 Typ. | 5 | 160 | 1.5 |
| EXC28CH900U | 90 Ω ±20 % | 15 Ω max. | 6 Typ. | 5 | 130 | 2.5 |

● Category Temperature Range -40 °C to +85 °C

Impedance Characteristics (Typical)

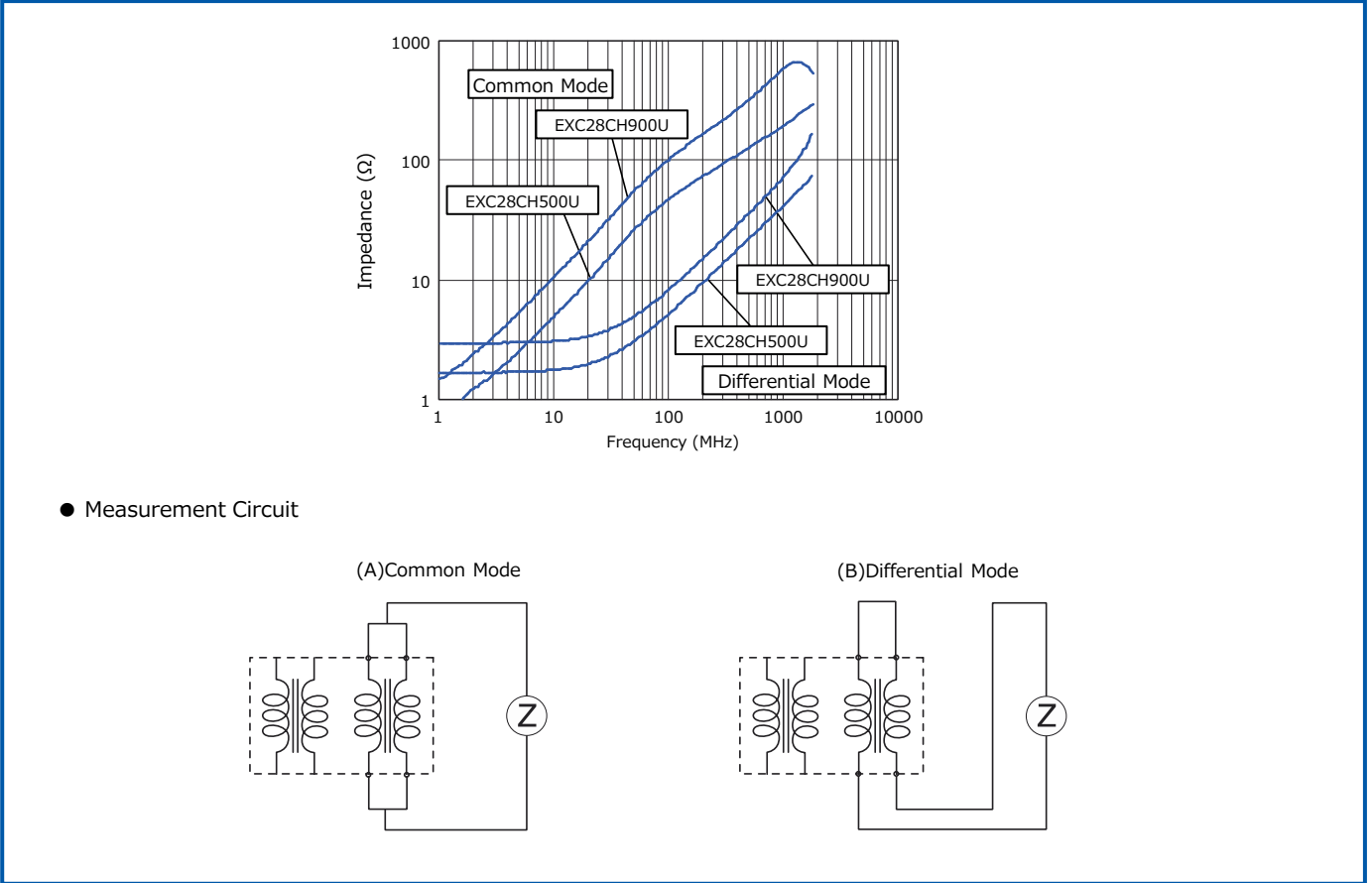

● Measurement Circuit

Insertion Loss (Typical)

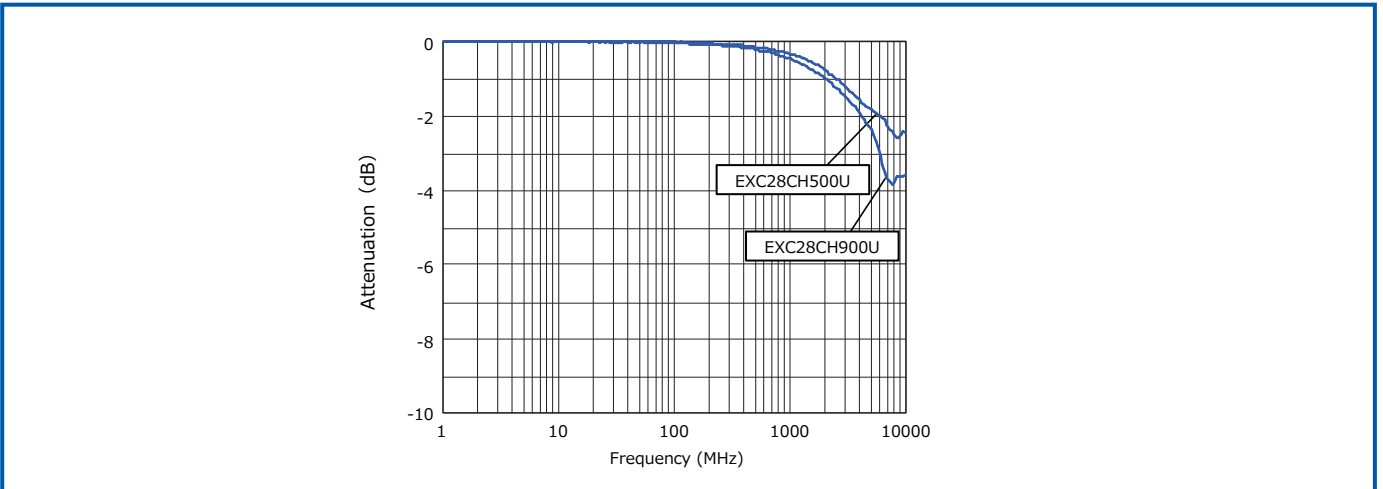

■ As for Packaging Methods, Land Pattern, Soldering Conditions and Safety Precautions, Please see Data Files

Common mode Noise Filters Array

Type: **EXC28CG**



Features

- Small and thin type, two built-in filter circuit (L 2.0 mm×W 1.0 mm×H 0.5 mm)
- Prevention of weakening of transmission signals by controlling signal pass band as 3 GHz or above
- Prevention of reflection of transmission signals and noise radiation by controlling TDR characteristic impedance as 100 Ω
- Satisfaction of eye pattern standards of HDMI waveforms with capability to improve waveform fluctuations of Jitter and phase shift etc
- Elimination of radiation noises from high-speed differential transmissions
- Magnetic shield type with no leakage
- RoHS compliant

Recommended Applications

- AV equipment (LCD-TV, DVD/Blu-ray drives), Information equipment (PCs, HDD), Communications equipment (Mobile phones, Smartphones)
- Noise suppression of high-speed differential data lines such as HDMI, SATA and LAN

Explanation of Part Numbers

| | | | | | | | | | | | |
|--------------|----------|-------------------------|----------|---------------------|----------------|---|--|----------|----------|--|--------|
| 1 | 2 | 3 | 4 | 5 | 6 | 7 | 8 | 9 | 10 | 11 | 12 |
| E | X | C | 2 | 8 | C | G | 9 | 0 | 0 | U | |
| Product Code | | Size | | Number of Terminals | Type | Characteristics | Nominal Impedance | | Form | | Suffix |
| Noise Filter | Code | Dimensions(mm) | | 8 Terminals | C Coupled type | G High speed Differential transmission (for Gbps) | The first two digits are significant figure of impedance value, and the third one denotes the number of zeros following. | | Code | Packing | |
| | 2 | 2.0×1.0×0.5 (L)×(W)×(H) | | | | | | | U | Embossed Carrier Taping 4 mm pitch, 5,000 pcs | |

Construction

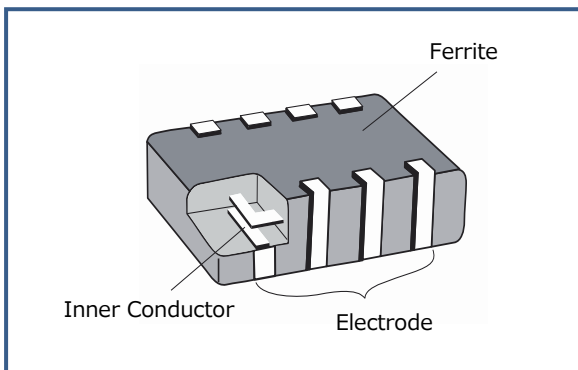

Dimensions in mm (not to scale)

| Part No. (inch size) | Dimensions(mm) | | | | | | Mass (Weight) (mg/ pc.) |
|-------------------------|----------------|---------|---------|-----------|---------|-----------|-------------------------------|
| | A | B | C | D | E | F | |
| EXC28CG (0804) | 1.00±0.15 | 2.0±0.2 | 0.5±0.1 | 0.20±0.15 | 0.5±0.1 | 0.25±0.10 | 5 |

Circuit Configuration (No Polarity)

※ The pin numbers shown here are for reference purposes only. Confirm the actual pin number arrangement with the exchanged specification documents.

| Ratings | | | | | |
|-------------|-----------------------------------|-------------------|----------------------|-----------------------|--------------------------------|
| Part Number | Impedance (Ω) at 100 MHz | | Rated Voltage (V) DC | Rated Current (mA) DC | DC Resistance (Ω)max. |
| | Common Mode | Differential Mode | | | |
| EXC28CG240U | 24 Ω \pm 25 % | 15 Ω max. | 5 | 160 | 1.5 |
| EXC28CG900U | 90 Ω \pm 25 % | 17 Ω max. | 5 | 130 | 3.0 |

● Category Temperature Range -40°C to $+85^{\circ}\text{C}$

Impedance Characteristics (Typical)

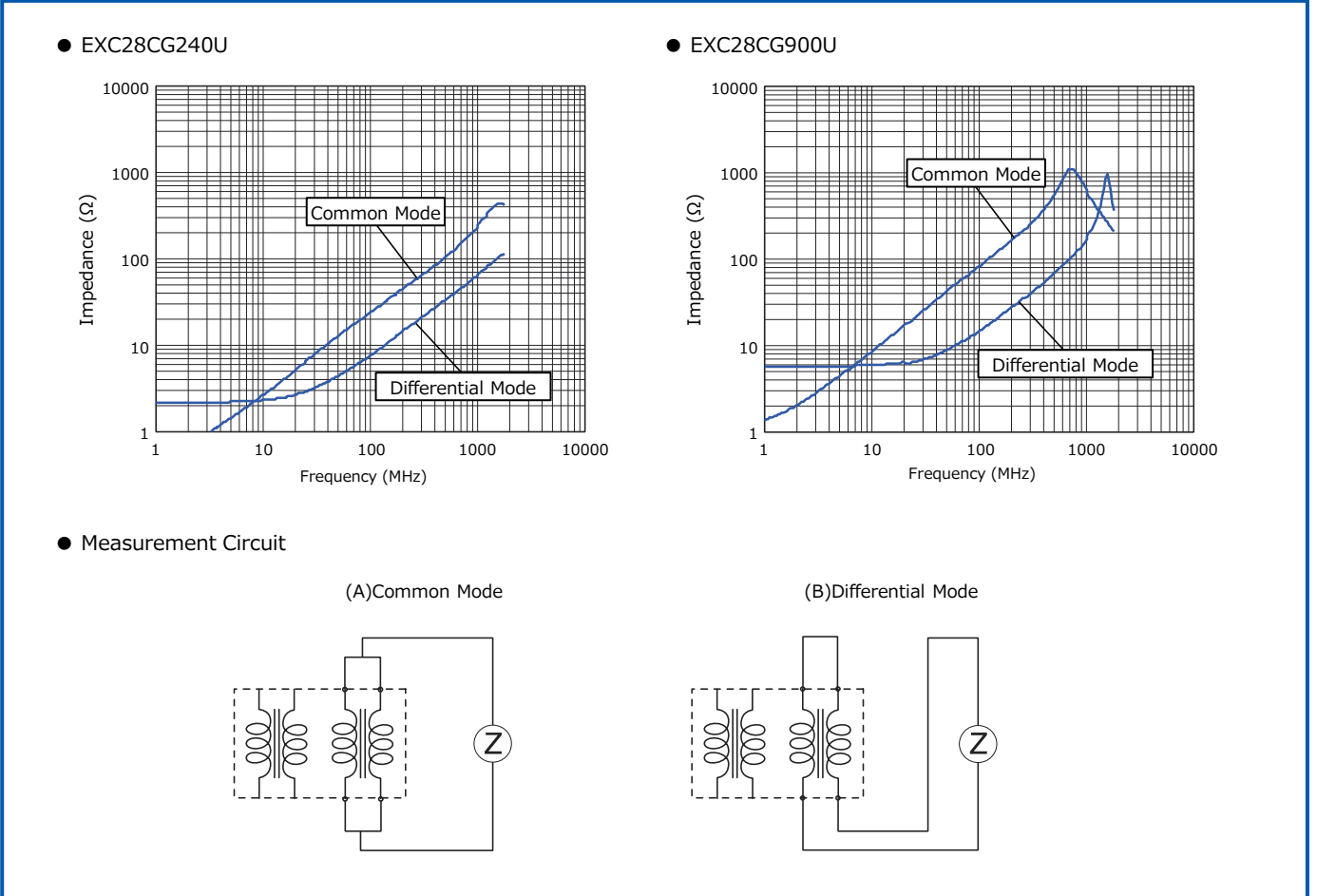

■ As for Packaging Methods, Land Pattern, Soldering Conditions and Safety Precautions, Please see Data Files

Common mode Noise Filters Array

Type: **EXC28CE**



Features

- Small and thin type, two built-in filter circuit (L 2.0 mm×W 1.0 mm×H 0.5 mm)
- Elimination of radiation noises from high-speed differential transmissions
- Magnetic shield type with no leakage
- Strong multilayer/sintered structure, excellent reflow resistance and high mounting reliability
- Lead, halogen and antimony-free
- RoHS compliant

Recommended Applications

- AV equipment (LCD-TV, DVD/Blu-ray drives), Information equipment (PCs, HDD, Printers), Communications equipment (Mobile phones, Smartphones)
- Noise suppression of high-speed differential data lines such as USB2.0 and LVDS

Explanation of Part Numbers

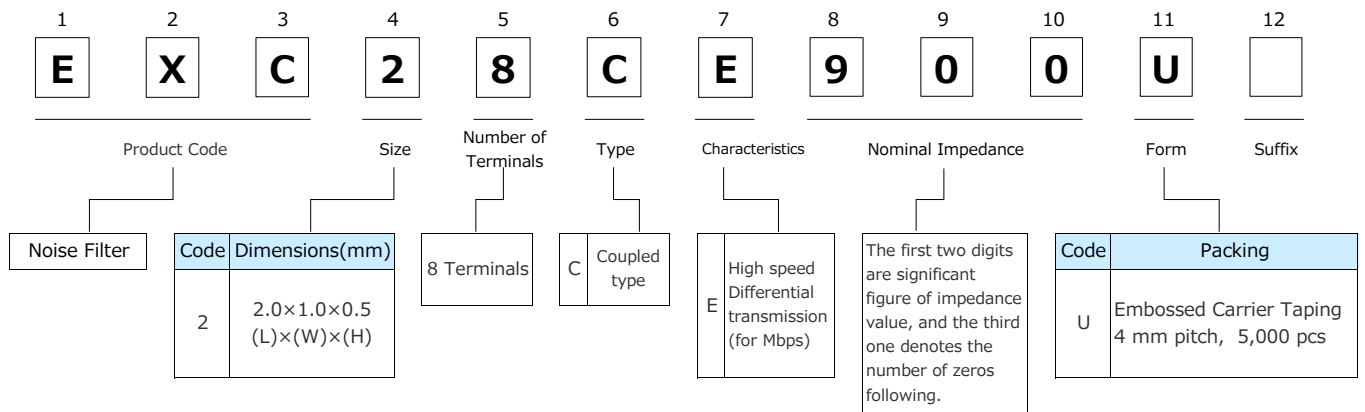

Construction

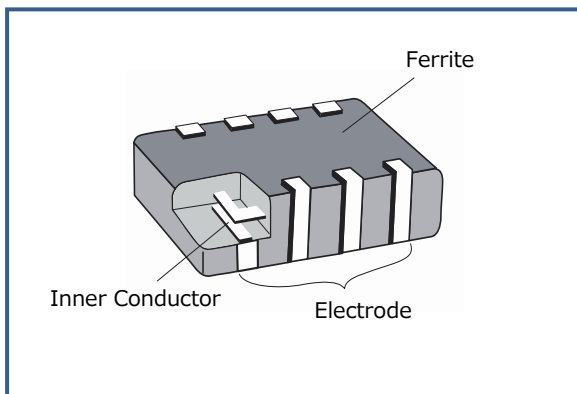

Dimensions in mm (not to scale)

| Part No. (inch size) | Dimensions(mm) | | | | | | Mass (Weight) (mg/ pc.) |
|-------------------------|----------------|-------------|-------------|---------------|-------------|---------------|-------------------------------|
| | A | B | C | D | E | F | |
| EXC28CE (0804) | 1.00 ±0.15 | 2.0 ±0.2 | 0.5 ±0.1 | 0.20 ±0.15 | 0.5 ±0.1 | 0.25 ±0.10 | 5 |

Circuit Configuration (No Polarity)

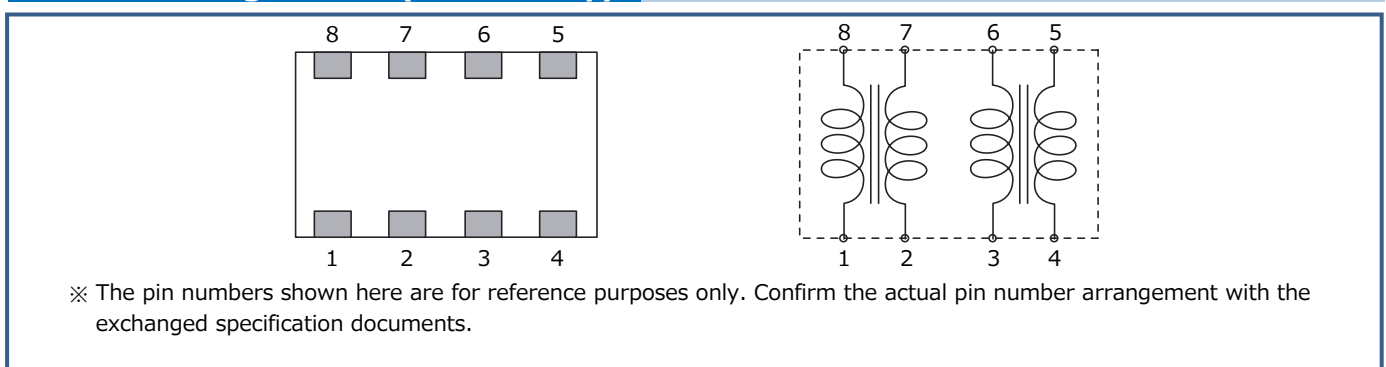

| Ratings | | | | | |
|-------------|-----------------------------------|-------------------|----------------------|-----------------------|--------------------------------|
| Part Number | Impedance (Ω) at 100 MHz | | Rated Voltage (V) DC | Rated Current (mA) DC | DC Resistance (Ω)max. |
| | Common Mode | Differential Mode | | | |
| EXC28CE900U | 90 Ω ±25 % | 15 Ω max. | 5 | 160 | 1.5 |
| EXC28CE121U | 120 Ω ±25 % | 18 Ω max. | 5 | 140 | 2.0 |
| EXC28CE201U | 200 Ω ±25 % | 20 Ω max. | 5 | 130 | 2.5 |

● Category Temperature Range -40 °C to +85 °C

Impedance Characteristics (Typical)

● EXC28CE900U

● EXC28CE121U

● EXC28CE201U

● Measurement Circuit

(A) Common Mode

(B) Differential Mode

■ As for Packaging Methods, Land Pattern, Soldering Conditions and Safety Precautions, Please see Data Files

Packaging Methods (Taping)

● Standard Quantity

| Part Number | Size (inch) | Type | Kind of Taping | Pitch (P ₁) | Quantity |
|-------------|-------------|--------|-------------------------|-------------------------|-------------------|
| EXCX4C | 0202 | Single | Pressed Carrier Taping | 2 mm | 10,000 pcs / reel |
| EXC14C | 0302 | | | 2 mm | 10,000 pcs / reel |
| EXC16C | 0403 | | Embossed Carrier Taping | 4 mm | 5,000 pcs / reel |
| EXC24C | 0504 | | | | |
| EXC34C | 0805 | Array | Embossed Carrier Taping | 4 mm | 5,000 pcs / reel |
| EXC18C | 0603 | | | | |
| EXC28C | 0804 | | | | |

● Pressed Carrier Taping
EXCX4C

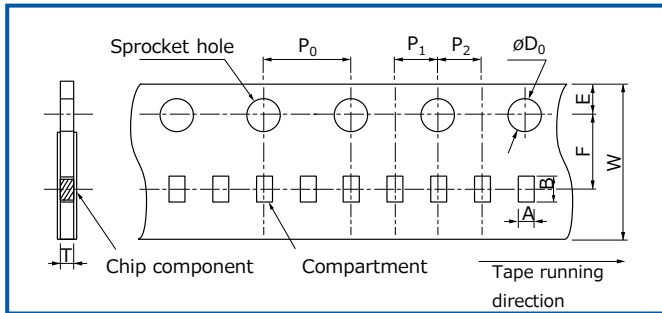

● Embossed Carrier Taping
EXC14C, 16C

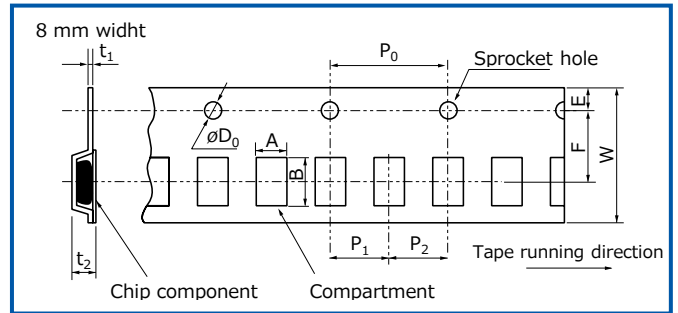

● Embossed Carrier Taping
EXC18C, 24C, 28C, 34C

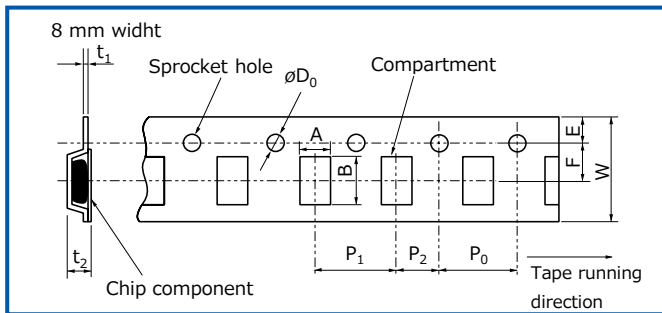

● Taping Reel

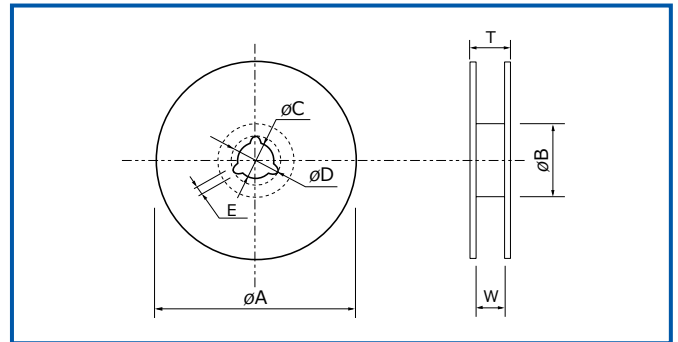

● Pressed Carrier Taping

| Part Number | A | B | W | F | E | P ₁ | P ₂ | P ₀ | øD ₀ | T |
|-------------|-----------|-----------|---------|-----------|-----------|----------------|----------------|----------------|----------------------------------|-----------|
| EXCX4C | 0.60±0.10 | 0.80±0.10 | 8.0±0.2 | 3.50±0.05 | 1.75±0.10 | 2.0±0.1 | 2.0±0.1 | 4.0±0.1 | 1.5 ^{+0.1} ₀ | 0.35 typ. |

● Embossed Carrier Taping

| Part Number | A | B | W | F | E | P ₁ | P ₂ | P ₀ | øD ₀ | t ₁ | t ₂ |
|-------------|-----------|-----------|---------|-----------|-----------|----------------|----------------|----------------|----------------------------------|----------------|----------------|
| EXC14C | 0.75±0.10 | 0.95±0.10 | 8.0±0.2 | 3.50±0.05 | 1.75±0.10 | 2.0±0.1 | 2.0±0.1 | 4.0±0.1 | 1.5 ^{+0.1} ₀ | 0.25±0.05 | 0.85±0.15 |
| EXC16C | 0.77±0.10 | 0.99±0.10 | | | | | | | | | 0.80±0.15 |
| EXC18C | 1.00±0.10 | 1.80±0.10 | 8.0±0.2 | 3.5±0.1 | 1.75±0.10 | 4.0±0.1 | 2.0±0.1 | 4.0±0.1 | 1.5 ^{+0.1} ₀ | 0.25±0.05 | 0.80±0.05 |
| EXC24C | 1.20±0.15 | 1.45±0.15 | | | | | | | | | |
| EXC28C | 1.20±0.15 | 2.25±0.15 | | | | | | | | | |
| EXC34C | 1.50±0.20 | 2.30±0.20 | | | | | | | | | 0.90±0.15 |

● Taping Reel

Standard Reel Dimensions

| Part Number | øA | øB | øC | øD | E | W | T |
|-------------|-----------|----------|----------|----------|---------|---------|----------|
| EXCX4C | 180.0±3.0 | 60.0±1.0 | 13.0±0.2 | 21.0±0.8 | 2.0±0.5 | 9.0±0.3 | 11.4±1.0 |
| EXC14C | | | 13.0±0.5 | | | | 11.4±1.5 |
| EXC16C | | | | | | | |
| EXC18C | | | | | | | |
| EXC24C | | | | | | | |
| EXC28C | | | | | | | |
| EXC34C | | | | | | | |

Recommended Land Pattern Design

● Single

EXCX4C, 14C, 24C, 34C

EXC16C

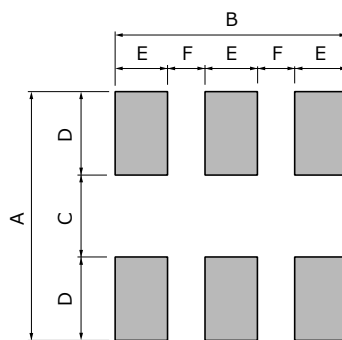
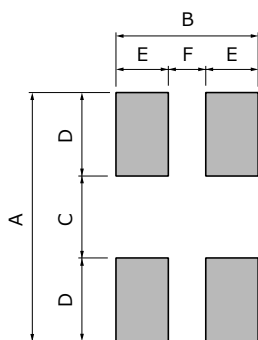

● Array

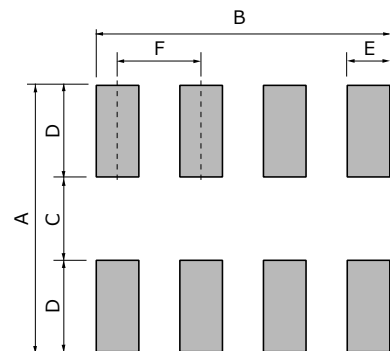

| Part Number | Dimensions (mm) | | | | | |
|-------------|-----------------|--------------|--------------|--------------|--------------|--------------|
| | A | B | C | D | E | F |
| EXCX4C | 0.80 to 0.90 | 0.60 to 0.75 | 0.20 to 0.30 | 0.30 | 0.20 to 0.25 | 0.20 to 0.25 |
| EXC14C | 0.80 to 1.00 | 0.80 | 0.30 | 0.25 to 0.35 | 0.30 | 0.20 |
| EXC24C | 1.60 to 2.00 | 0.95 | 0.70 | 0.45 to 0.65 | 0.35 | 0.25 |
| EXC34C | 2.60 | 1.20 | 1.10 | 0.75 | 0.40 | 0.40 |
| EXC16C | 0.99 | 0.85 | 0.33 | 0.33 | 0.15 | 0.20 |

| Part Number | Dimensions (mm) | | | | | |
|-------------|-----------------|------|-----|-----|------|-----|
| | A | B | C | D | E | F |
| EXC18C | 1.4 | 1.4 | 0.4 | 0.5 | 0.2 | 0.4 |
| EXC28C | 1.4 | 1.75 | 0.4 | 0.5 | 0.25 | 0.5 |

Recommended Soldering Conditions

Recommendations and precautions are described below

● **Recommended soldering conditions for reflow**

- Reflow soldering shall be performed a maximum of two times.
- Please contact us for additional information when used in conditions other than those specified.
- Please measure the temperature of the terminals and study every kind of solder and printed circuit board for solderability before actual use.

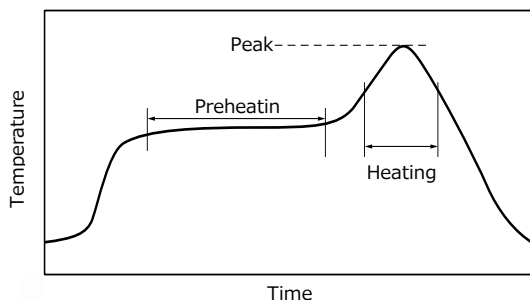

For soldering (Example : Sn-37Pb)

| | Temperature | Time |
|--------------|------------------|---------------|
| Preheating | 140 °C to 160 °C | 60 s to 120 s |
| Main heating | Above 200 °C | 30 s to 40 s |
| Peak | 235 ± 10 °C | max. 10 s |

For lead-free soldering (Example :Sn-3Ag-0.5Cu)

| | Temperature | Time |
|--------------|------------------|---------------|
| Preheating | 150 °C to 170 °C | 60 s to 120 s |
| Main heating | Above 230 °C | 30 s to 40 s |
| Peak | max. 260 °C | max. 10 s |

● **Flow soldering**

- We do not recommend flow soldering, because flow soldering may cause bridges between the electrodes.

《Repair with hand soldering》

- Preheat with a blast of hot air or similar method. Use a soldering iron with a tip temperature of 350 °C or less. Solder each electrode for 3 seconds or less.
- Never touch this product with the tip of a soldering iron.

Common mode Noise Filters with ESD Suppressor

Type: **EXC14CS**



This series is not a recommended product.
Not recommended for new design.

Features

- Provides EMI Filtering and ESD Protection (L 0.85 mm×W 0.65 mm×H 0.45mm)
- ESD and noise suppression of high-speed differential transmission lines with little influence of waveform rounding on signal transmission
- High Common mode attenuation in the range between 700 MHz and 1000 MHz (RF band)
- Strong multilayer/sintered structure, excellent reflow resistance and high mounting reliability
- Lead, halogen and antimony-free
- RoHS compliant

Recommended Applications

- Smartphones, Tablet PCs and DSC
- ESD and noise suppression of high-speed differential data lines such as MIPI and USB

Explanation of Part Numbers

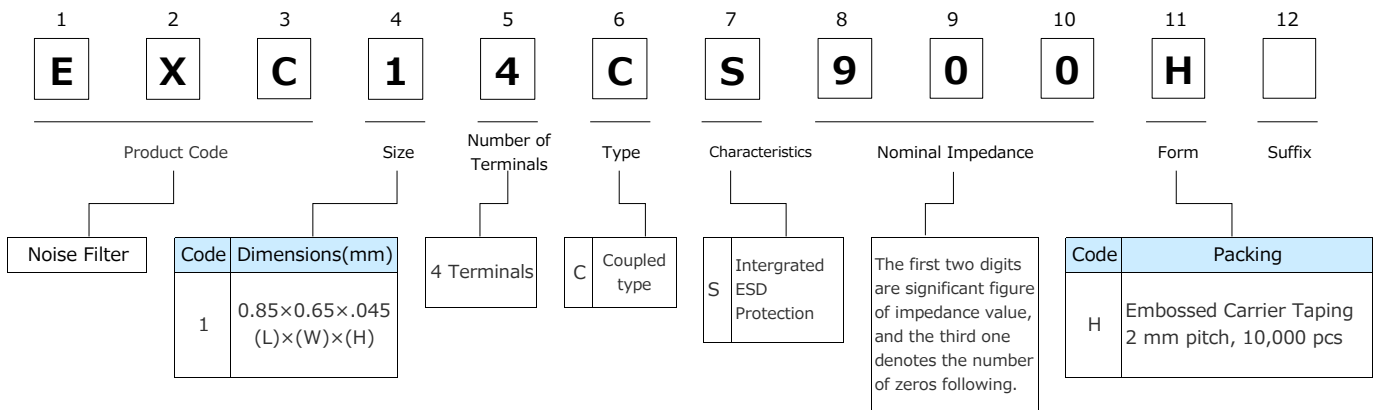

Construction

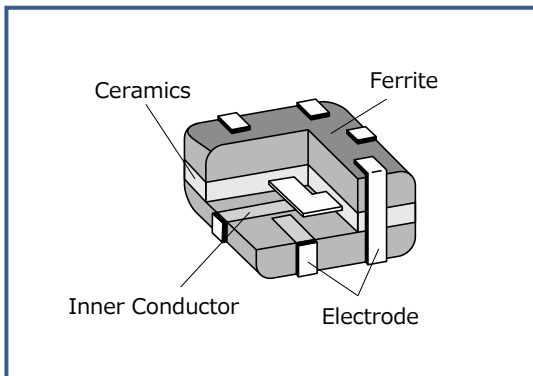

Dimensions in mm (not to scale)

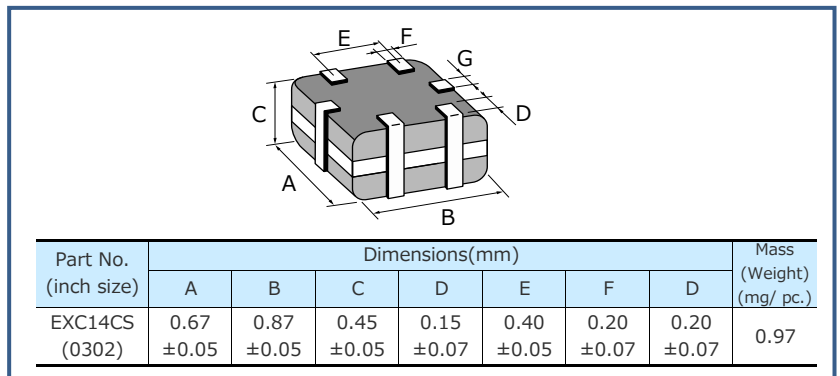

Circuit Configuration (No Polarity)

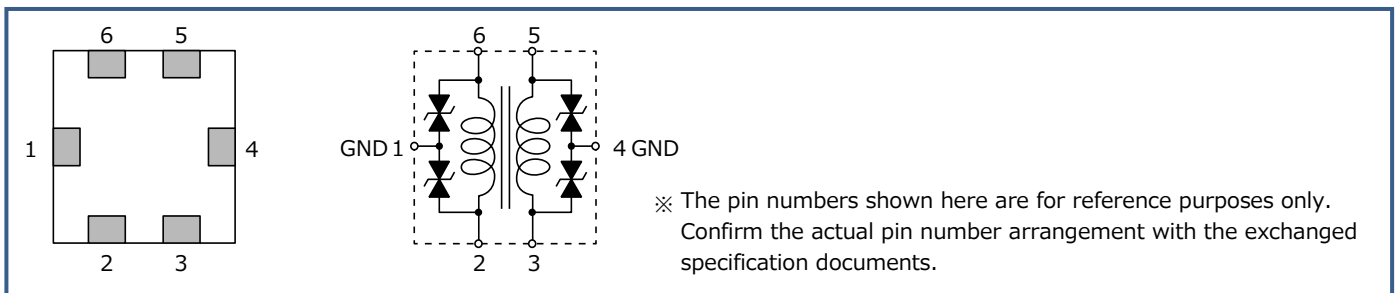

Ratings

| Part Number | Impedance (Ω) at 100 MHz | | Rated Voltage (V) DC | Rated Current (mA) DC | DC Resistance (Ω)max. |
|-------------|-----------------------------------|-------------------|----------------------|-----------------------|--------------------------------|
| | Common Mode | Differential Mode | | | |
| EXC14CS350H | 35 Ω ±30 % | 15 Ω max. | 5 | 100 | 2.0±30 % |
| EXC14CS900H | 90 Ω ±20 % | 20 Ω max. | 5 | 100 | 3.3±30 % |

● Category Temperature Range -40 °C to +85 °C

Impedance Characteristics (Typical)

● EXC14CS350H

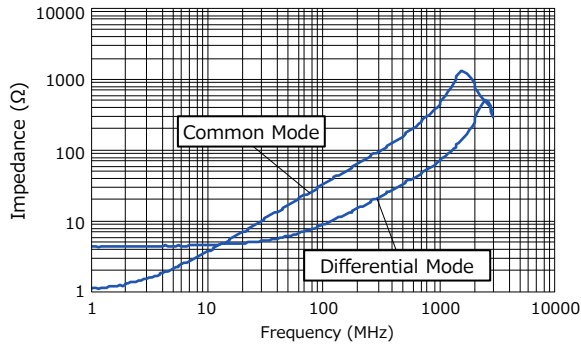

● EXC14CS900H

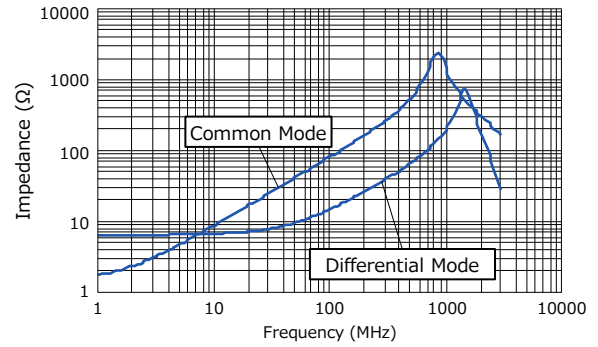

● Measurement Circuit

(A) Common Mode

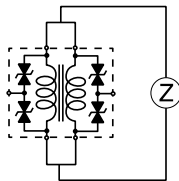

(B) Differential Mode

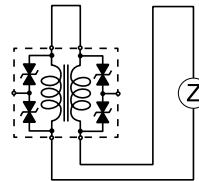

ESD Suppression Characteristics (Typ. : IEC6100-4-2, 8 kV contact discharge)

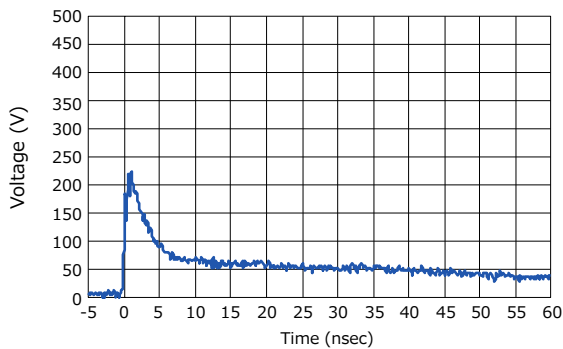

Recommended Land Pattern Design in mm (not to scale)

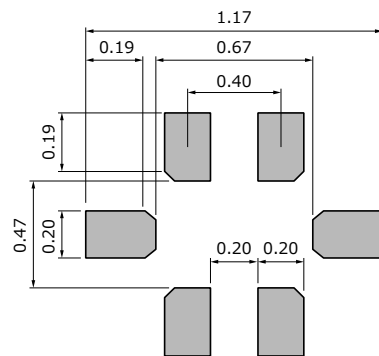

■ As for Packaging Methods, Soldering Conditions and Safety Precautions, Please see Data Files

Common mode Noise Filters with ESD Suppressor

Type: **EXC24CS**



This series is not a recommended product.
Not recommended for new design.

Features

- Provides EMI Filtering and ESD Protection (L 1.25 mm×W 1.00 mm×H 0.50 mm)
- ESD and noise suppression of high-speed differential transmission lines with little influence of waveform rounding on signal transmission
- High Common mode attenuation in the range between 700 MHz and 1000 MHz (RF band)
- Strong multilayer/sintered structure, excellent reflow resistance and high mounting reliability
- Lead, halogen and antimony-free
- RoHS compliant

Recommended Applications

- Smartphones, Tablet PCs and DSC
- ESD and noise suppression of high-speed differential data lines such as MIPI and USB

Explanation of Part Numbers

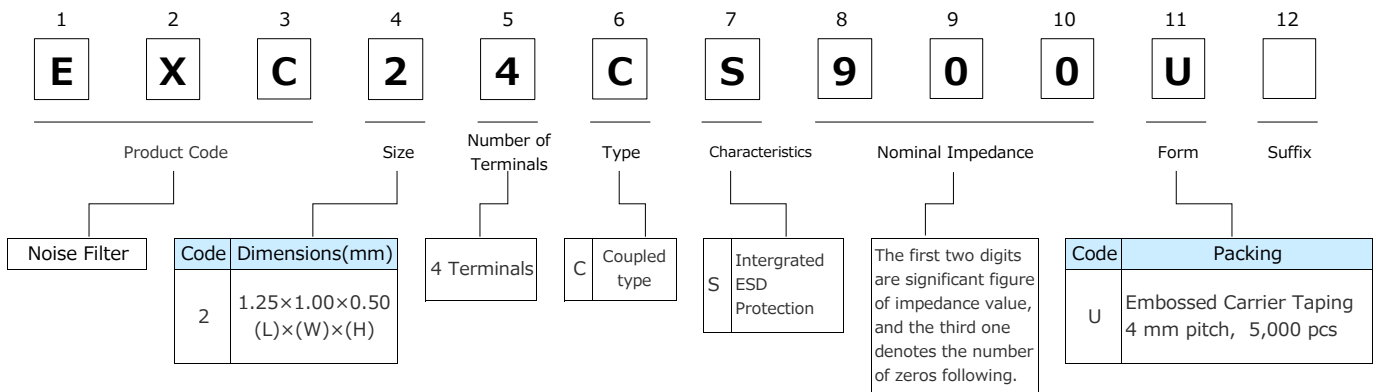

Construction

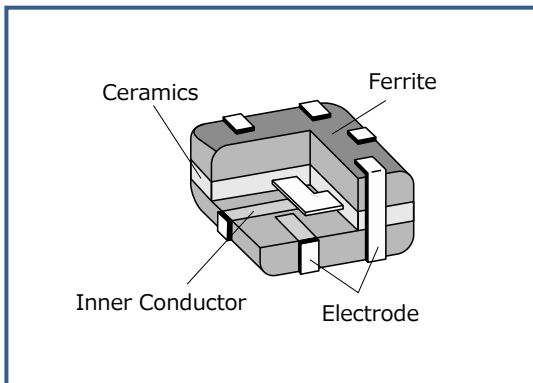

Dimensions in mm (not to scale)

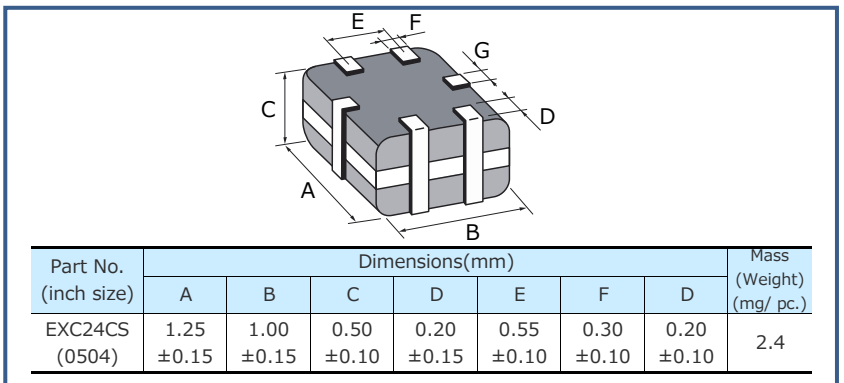

Circuit Configuration (No Polarity)

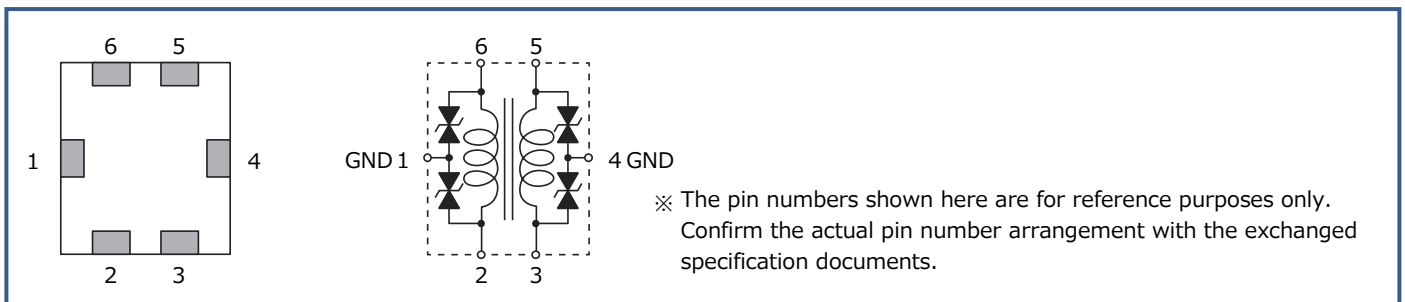

Ratings

| Part Number | Impedance (Ω) at 100 MHz | | Rated Voltage (V) DC | Rated Current (mA) DC | DC Resistance (Ω)max. |
|-------------|-----------------------------------|-------------------|----------------------|-----------------------|--------------------------------|
| | Common Mode | Differential Mode | | | |
| EXC24CS350U | 35 Ω ±30 % | 15 Ω max. | 5 | 100 | 2.0 |
| EXC24CS900U | 90 Ω ±20 % | 20 Ω max. | 5 | 100 | 3.0 |

● Category Temperature Range -40 °C to +85 °C

Impedance Characteristics (Typical)

● EXC24CS350U

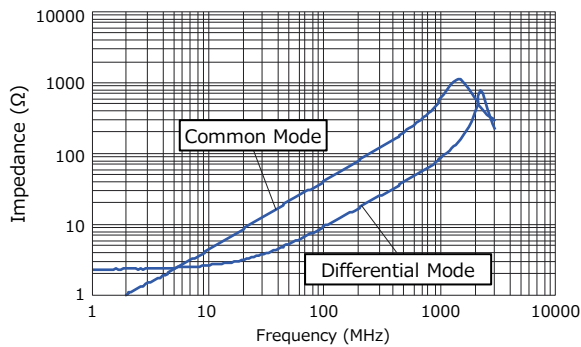

● EXC24CS900U

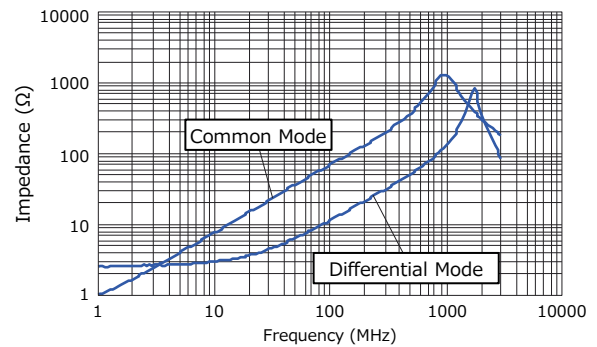

● Measurement Circuit

(A) Common Mode

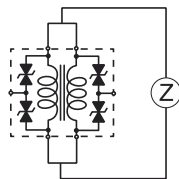

(B) Differential Mode

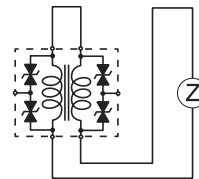

ESD Suppression Characteristics (Typ. : IEC6100-4-2, 8 kV contact discharge)

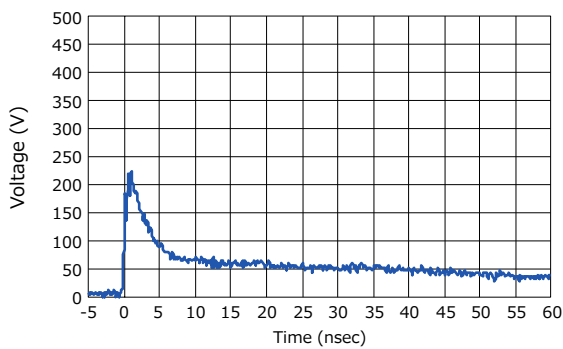

Recommended Land Pattern Design in mm (not to scale)

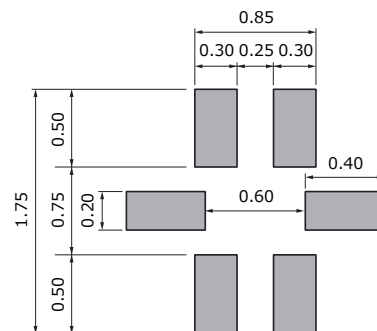

■ As for Packaging Methods, Soldering Conditions and Safety Precautions, Please see Data Files

Common mode Noise Filters Array with ESD Suppressor

Type: EXC18CS



This series is not a recommended product.
Not recommended for new design.

Features

- Provides EMI Filtering and ESD Protection (L 1.6 mm ×W 0.8 mm×H 0.4 mm)
- ESD and noise suppression of high-speed differential transmission lines with little influence of waveform rounding on signal transmission
- High Common mode attenuation in the range between 700 MHz and 1000 MHz (RF band)
- Strong multilayer/sintered structure, excellent reflow resistance and high mounting reliability
- Lead, halogen and antimony-free
- RoHS compliant

Recommended Applications

- Smartphones, Tablet PCs and DSC
- ESD and noise suppression of high-speed differential data lines such as MIPI and USB

Explanation of Part Numbers

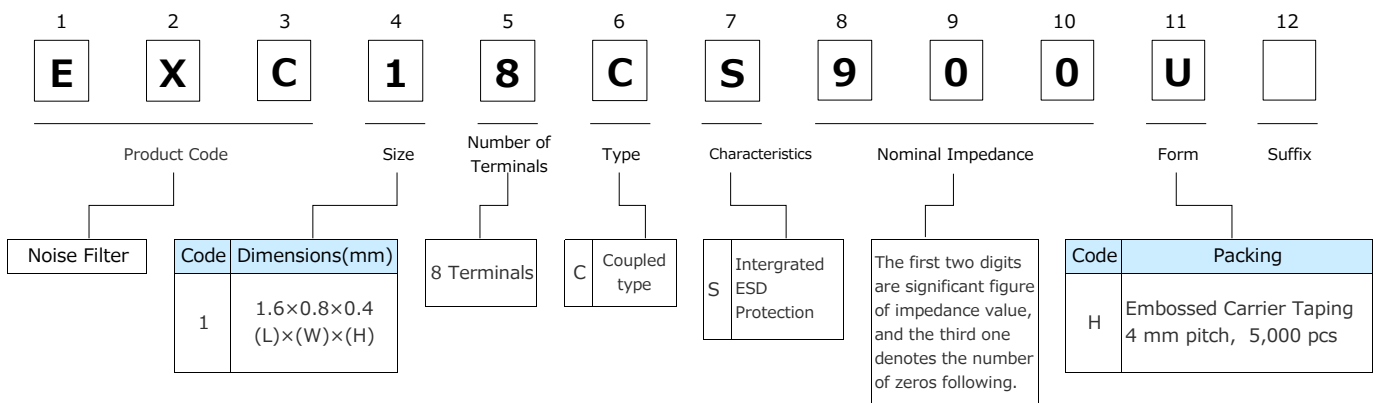

Construction

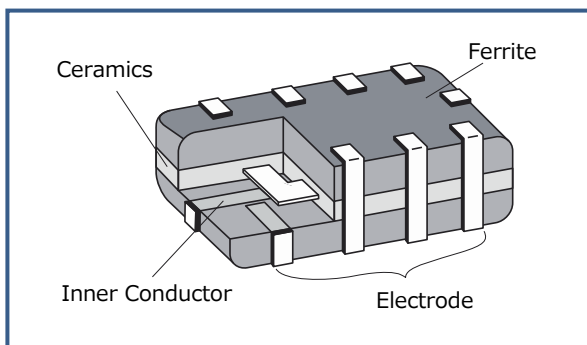

Dimensions in mm (not to scale)

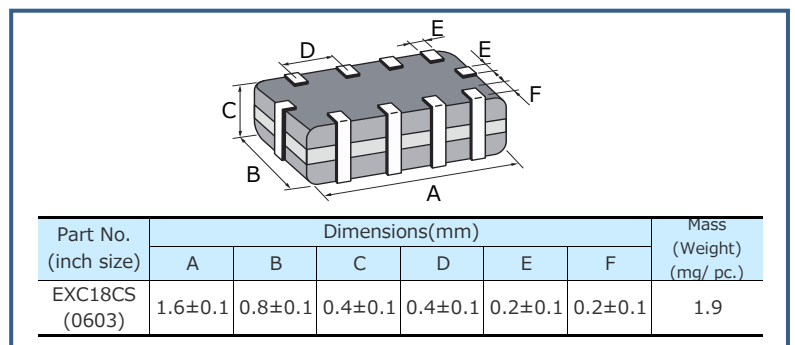

Circuit Configuration (No Polarity)

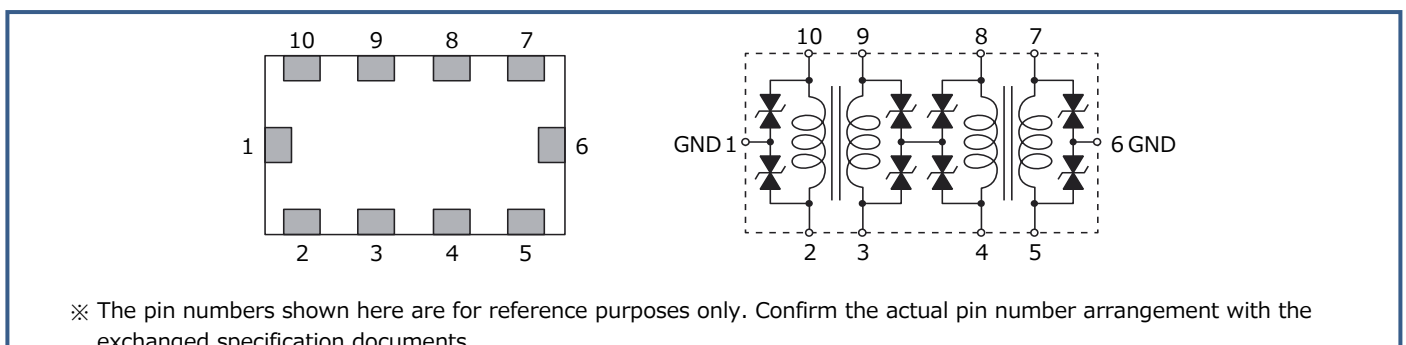

Ratings

| Part Number | Impedance (Ω) at 100 MHz | | Rated Voltage (V) DC | Rated Current (mA) DC | DC Resistance (Ω) |
|-------------|-----------------------------------|-------------------|----------------------|-----------------------|----------------------------|
| | Common Mode | Differential Mode | | | |
| EXC18CS350U | 35 Ω \pm 30 % | 15 Ω max. | 5 | 100 | 1.8 \pm 30 % |
| EXC18CS900U | 90 Ω \pm 20 % | 20 Ω max. | 5 | 100 | 3.0 \pm 30 % |

● Category Temperature Range -40 °C to +85 °C

Impedance Characteristics (Typical)

● EXC18CS350U

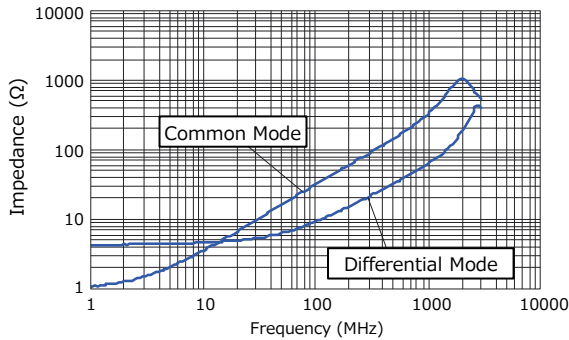

● EXC18CS900U

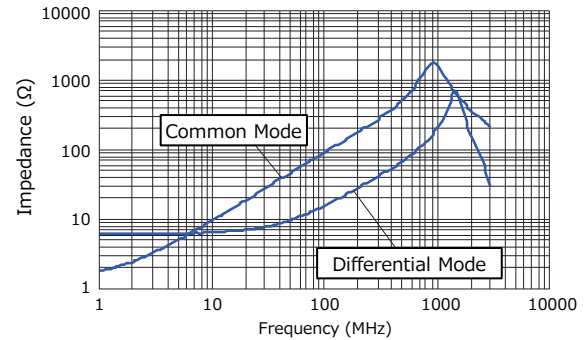

● Measurement Circuit

(A) Common Mode

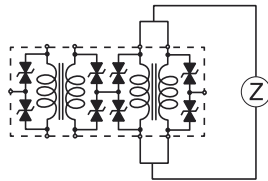

(B) Differential Mode

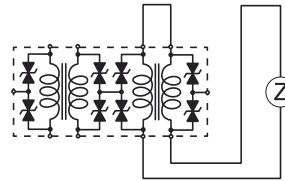

ESD Suppression Characteristics (Typ. : IEC6100-4-2, 8 kV contact discharge)

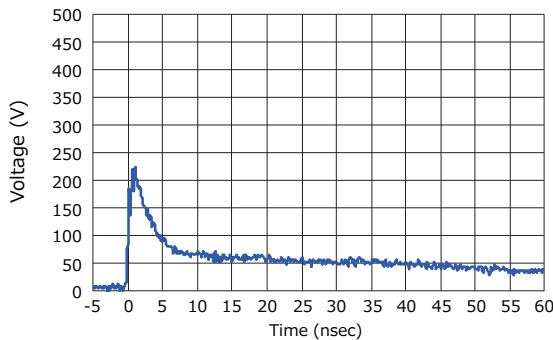

Recommended Land Pattern Design in mm (not to scale)

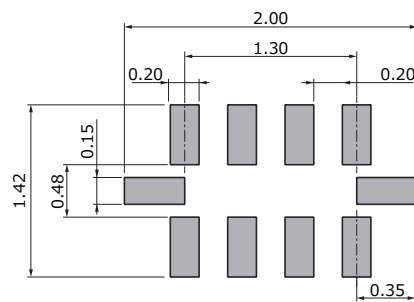

■ As for Packaging Methods, Soldering Conditions and Safety Precautions, Please see Data Files

Packaging Methods (Taping)

● Standard Quantity

| Part Number | Size (inch) | Type | Kind of Taping | Pitch (P ₁) | Quantity |
|-------------|-------------|--------|-------------------------|-------------------------|-------------------|
| EXC14CS | 0302 | Single | Embossed Carrier Taping | 2 mm | 10,000 pcs / reel |
| EXC24CS | 0504 | | | 4 mm | 5,000 pcs / reel |
| EXC18CS | 0603 | Array | | | |

● Embossed Carrier Taping
EXC14CS

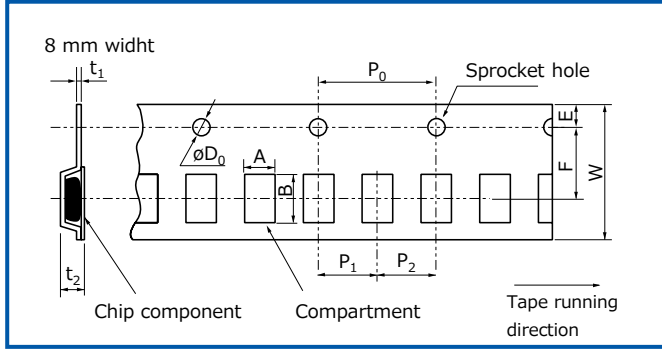

● Embossed Carrier Taping
EXC18CS, EXC24CS

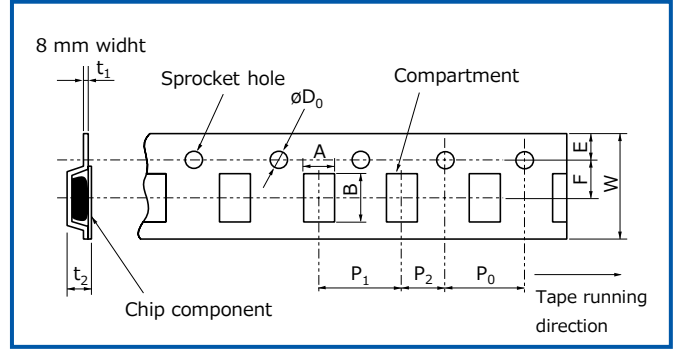

● Taping Reel

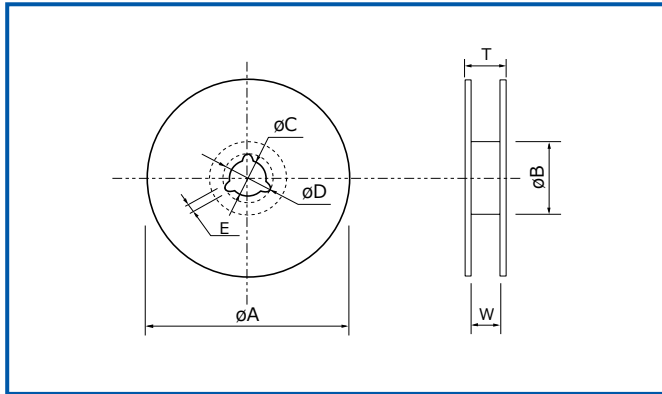

● Embossed Carrier Taping

(mm)

| Part Number | A | B | W | F | E | P ₁ | P ₂ | P ₀ | øD ₀ | t ₁ | t ₂ |
|-------------|-----------|-----------|---------|-----------|-----------|----------------|----------------|----------------|----------------------------------|----------------|----------------|
| EXC14CS | 0.75±0.10 | 0.95±0.10 | 8.0±0.2 | 3.50±0.05 | 1.75±0.10 | 2.0±0.1 | 2.0±0.1 | 4.0±0.1 | 1.5 ^{+0.1} ₀ | 0.25±0.05 | 0.85±0.15 |
| EXC18CS | 1.00±0.10 | 1.80±0.10 | 8.0±0.2 | 3.5±0.1 | 1.75±0.10 | 4.0±0.1 | 2.0±0.1 | 4.0±0.1 | 1.5 ^{+0.1} ₀ | 0.25±0.05 | 0.50±0.05 |
| EXC24CS | 1.20±0.15 | 1.45±0.15 | | | | | | | | | 0.90±0.15 |

● Taping Reel

Standard Reel Dimensions

(mm)

| Part Number | øA | øB | øC | øD | E | W | T |
|-------------------------------|-----------|----------|----------|----------|---------|---------|----------|
| EXC14CS EXC18CS EXC24CS | 180.0±3.0 | 60.0±1.0 | 13.0±0.5 | 21.0±0.8 | 2.0±0.5 | 9.0±0.3 | 11.4±1.5 |

Recommended Soldering Conditions

Recommendations and precautions are described below

● Recommended soldering conditions for reflow

- Reflow soldering shall be performed a maximum of two times.
- Please contact us for additional information when used in conditions other than those specified.
- Please measure the temperature of the terminals and study every kind of solder and printed circuit board for solderability before actual use.

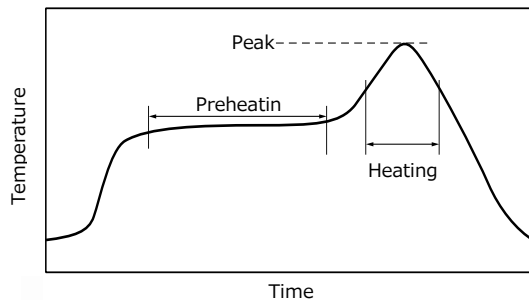

● Flow soldering

- We do not recommend flow soldering, because flow soldering may cause bridges between the electrodes.

For soldering (Example : Sn-37Pb)

| | Temperature | Time |
|--------------|------------------|---------------|
| Preheating | 140 °C to 160 °C | 60 s to 120 s |
| Main heating | Above 200 °C | 30 s to 40 s |
| Peak | 235 ± 10 °C | max. 10 s |

For lead-free soldering (Example :Sn-3Ag-0.5Cu)

| | Temperature | Time |
|--------------|------------------|---------------|
| Preheating | 150 °C to 170 °C | 60 s to 120 s |
| Main heating | Above 230 °C | 30 s to 40 s |
| Peak | max. 260 °C | max. 10 s |

《Repair with hand soldering》

- Preheat with a blast of hot air or similar method. Use a soldering iron with a tip temperature of 350 °C or less. Solder each electrode for 3 seconds or less.
- Never touch this product with the tip of a soldering iron.

Replacement list for "Not recommended for new design"

* If you are using any of the following models on the deleted list, please substitute them with the suggested alternative model as soon as possible.

| Non-recommended part number | | | | Replacement part number | | | | | | | |
|---|-----------|------------------------|-----------------------------|------------------------------|-----------|-------------------------|-----------------------------|-----------------------------|-----------|------------------|---------------------|
| Common mode Noise Filters with ESD Suppressor | | | | Common mode Noise Filters | | | | ESD Suppressor | | | Combination Pattern |
| Part Number | Inch size | ESD protection element | Impedance (Common Mode) | Part Number | Inch size | Impedance (Common Mode) | Number of pieces | Part Number | Inch size | Number of pieces | |
| EXC14CS350U | 0302 | 2 line | 35 Ω | EXC14CH350U | 0302 | 35 Ω | 1 | EZAEG1N50AC | 0201 | 2 | ① |
| | | | | EXC14CH350U | 0302 | 35 Ω | 1 | EZAEG2N50AX | 0402 | 2 | ② |
| EXC14CS900U | 0302 | | 90 Ω | EXC14CE900U | 0302 | 90 Ω | 1 | EZAEG1N50AC | 0201 | 2 | ① ^{*1} |
| | | | | EXC14CE900U | 0302 | 90 Ω | 1 | EZAEG2N50AX | 0402 | 2 | ② ^{*1} |
| | | | EXC24CH900U | 0504 | 90 Ω | 1 | EZAEG1N50AC | 0201 | 2 | ③ | |
| | | | EXC24CH900U | 0504 | 90 Ω | 1 | EZAEG2N50AX | 0402 | 2 | ④ | |
| EXC24CS350U | 0504 | | 35 Ω | EXC24CH500U | 0504 | 50 Ω | 1 | EZAEG1N50AC | 0201 | 2 | ① |
| | | | | EXC24CH500U | 0504 | 50 Ω | 1 | EZAEG2N50AX | 0402 | 2 | ② |
| | | | | EXC24CE360UP | 0504 | 36 Ω | 1 | EZAEG1N50AC | 0201 | 2 | ③ ^{*1} |
| | | | | EXC24CE360UP | 0504 | 36 Ω | 1 | EZAEG2N50AX | 0402 | 2 | ④ ^{*1} |
| EXC24CS900U | 0504 | | 90 Ω | EXC24CH900U | 0504 | 90 Ω | 1 | EZAEG1N50AC | 0201 | 2 | ① |
| | | | | EXC24CH900U | 0504 | 90 Ω | 1 | EZAEG2N50AX | 0402 | 2 | ② |
| EXC18CS350U | 0603 | 4 line | 35 Ω | EXC14CH350U | 0302 | 35 Ω | 2 | EZAEG1N50AC | 0201 | 4 | ① ^{*2} |
| | | | | EXC14CH350U | 0302 | 35 Ω | 2 | EZAEG2N50AX | 0402 | 4 | ② ^{*2} |
| EXC18CS900U | 0603 | | 90 Ω | EXC18CE900U | 0603 | 90 Ω | 1 | EZAEG1N50AC | 0201 | 4 | ① ^{*1} |
| | | | | EXC18CE900U | 0603 | 90 Ω | 1 | EZAEG2N50AX | 0402 | 4 | ② ^{*1} |
| | | | | EXC24CH900U | 0504 | 90 Ω | 2 | EZAEG1N50AC | 0201 | 4 | ③ ^{*2} |
| | | | | EXC24CH900U | 0504 | 90 Ω | 2 | EZAEG2N50AX | 0402 | 4 | ④ ^{*2} |

*1: USB2.0, LVDS(<1Gbps) only

*2: No replacement part number for Array products

2 mode Noise Filters

Type: **EXC14CP**



Features

- Small size and low-profile : 0302 inch size (L 0.85 mm×W 0.65 mm×H 0.45 mm)
- Burst/radiation noise filtering for audio circuits
- The optimally magnetic-coupled ferrite beads allow for the filtering of both common and normal mode noises
- The strong multi-layer structure provides high resistance to reflow soldering heat and a high mounting reliability
- Lead, halogen, and antimony free
- RoHS compliant

Recommended Applications

- Smart phones, Tablet PCs, DSC and Portable Music Player
- Noise suppression of burst noise of Receiver/Microphone and D-class power amplifier

Explanation of Part Numbers

| | | | | | | | | | | | |
|--------------|----------|----------------------------|----------|---------------------|----------------|-----------------|--|----------|----------|----------|---|
| 1 | 2 | 3 | 4 | 5 | 6 | 7 | 8 | 9 | 10 | 11 | 12 |
| E | X | C | 1 | 4 | C | P | 2 | 2 | 1 | U | |
| Product Code | | Size | | Number of Terminals | Type | Characteristics | Nominal Impedance | | | Form | Suffix |
| Noise Filter | Code | Dimensions(mm) | | 4 Terminals | C Coupled type | P Low DCR Type | The first two digits are significant figure of impedance value, and the third one denotes the number of zeros following. | | | Code | Packing |
| | 1 | 0.85×0.65×.045 (L)×(W)×(H) | | | | | | | | U | Embossed Carrier Taping 2 mm pitch, 10,000 pcs |

Construction

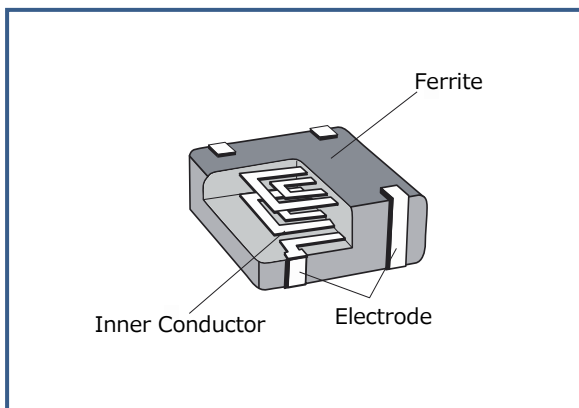

Dimensions in mm (not to scale)

| Part No. (inch size) | Dimensions(mm) | | | | | | Mass (Weight) (mg/ pc.) |
|-------------------------|----------------|---------------|---------------|--------------|---------------|---------------|-------------------------------|
| | A | B | C | D | E | F | |
| EXC14CP (0302) | 0.65 ±0.05 | 0.85 ±0.05 | 0.45 ±0.05 | 0.10 min. | 0.50 ±0.10 | 0.27 ±0.10 | 1.2 |

Circuit Configuration (No Polarity)

※ The pin numbers shown here are for reference purposes only. Confirm the actual pin number arrangement with the exchanged specification documents.

Ratings

| Part Number | Impedance (Ω) at 100 MHz | | Rated Voltage (V) DC | Rated Current (mA) DC | DC Resistance (Ω)max. |
|-------------|-----------------------------------|-----------------------|----------------------|-----------------------|--------------------------------|
| | Open mode | Common mode | | | |
| EXC14CP121U | 120 $\Omega \pm 30\%$ | 75 $\Omega \pm 25\%$ | 5 | 300 | 0.5 |
| EXC14CP221U | 220 $\Omega \pm 30\%$ | 140 $\Omega \pm 25\%$ | | 200 | 0.7 |

● Category Temperature Range $-40\text{ }^\circ\text{C}$ to $+85\text{ }^\circ\text{C}$

Impedance Characteristics (Typical)

● EXC14CP121U

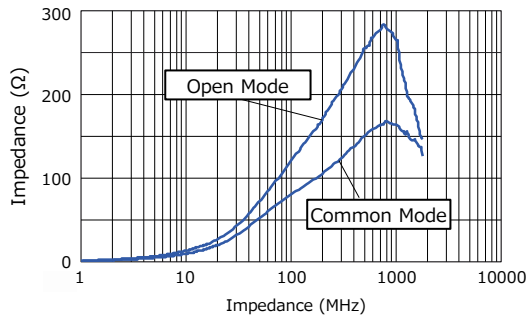

● EXC14CP221U

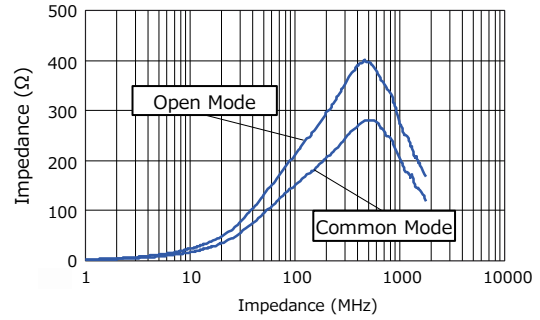

● Measurement Circuit

(A) Open Mode

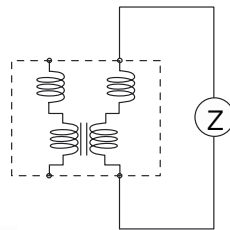

(B) Common Mode

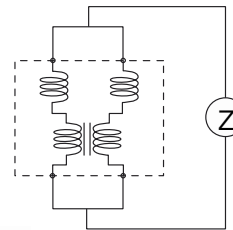

■ As for Packaging Methods, Land Pattern, Soldering Conditions and Safety Precautions, Please see Data Files

2 mode Noise Filters

Type: **EXC24CB/CP**

Type: **EXC24CN**



Features

- Burst/radiation noise filtering for audio circuits
- The optimally magnetic-coupled ferrite beads allow for the filtering of both common and normal mode noises
- The strong multi-layer structure provides high resistance to reflow soldering heat and a high mounting reliability
- Magnetic shield type
- High Impedance : 220 to 1 kΩ (EXC24CB type)
- Low Resistance Value : 0.4 Ω max. (EXC24CP type)
- High Impedance : 600 Ω, Low Resistance Value : 0.9 Ω max. (EXC24CN type)
- RoHS compliant

Recommended Applications

- Smart phones, Tablet PCs, DSC and Portable Music Player
- Noise suppression of burst noise of Receiver/Microphone and D-class power amplifier

Explanation of Part Numbers

● EXC24CB/CP Type

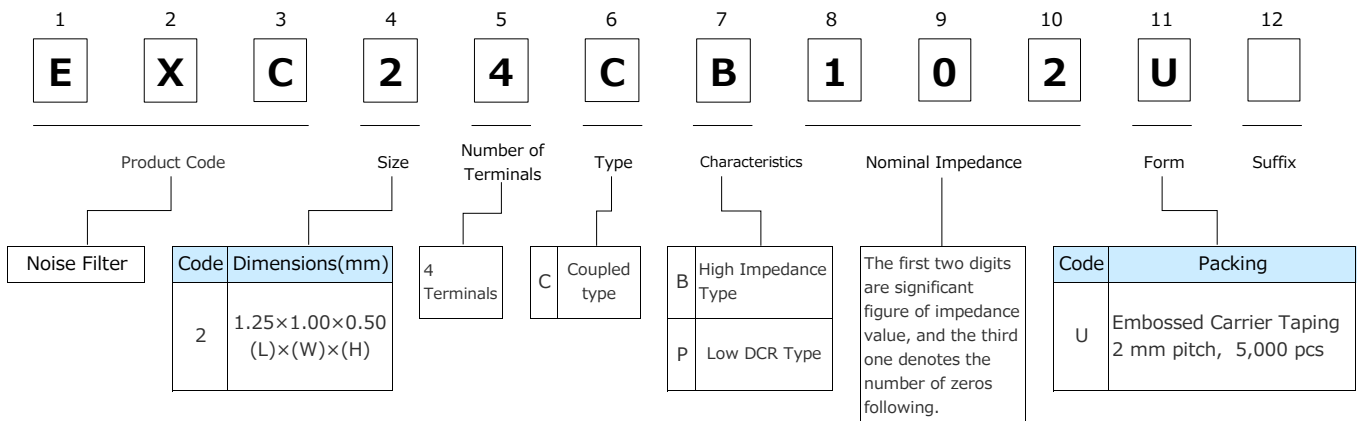

● EXC24CN Type

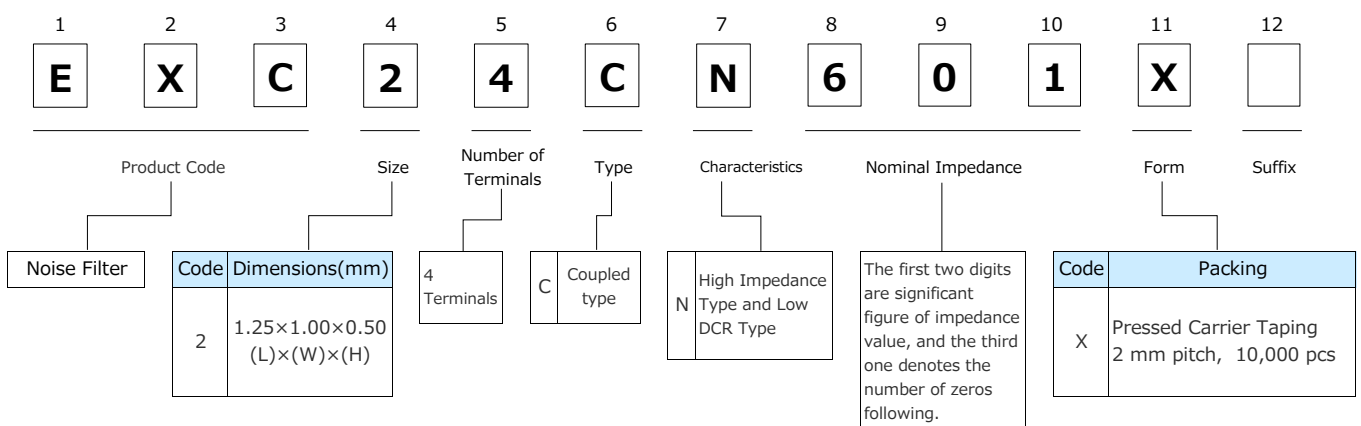

Construction

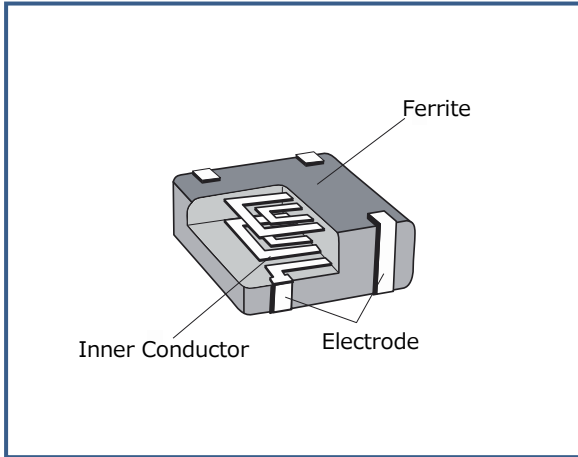

Dimensions in mm (not to scale)

| Part No. (inch size) | Dimensions(mm) | | | | | | Mass (Weight) (mg/ pc.) |
|-------------------------|----------------|---------------|---------------|---------------|---------------|---------------|-------------------------------|
| | A | B | C | D | E | F | |
| EXC24C (0504) | 1.00 ±0.15 | 1.25 ±0.15 | 0.50 ±0.10 | 0.20 ±0.15 | 0.65 ±0.10 | 0.35 ±0.10 | 3 |

Circuit Configuration (No Polarity)

※ The pin numbers shown here are for reference purposes only. Confirm the actual pin number arrangement with the exchanged specification documents.

Ratings

| Part Number | Impedance (Open mode) | | Rated Voltage (V) DC | Rated Current (mA) DC | DC Resistance (Ω)max. |
|-------------|-----------------------|---------------|-------------------------|--------------------------|--------------------------|
| | (Ω) at 100 MHz | Tolerance (%) | | | |
| EXC24CP121U | 120 | ±25 | 5 | 500 | 0.3 |
| EXC24CP221U | 220 | | | 350 | 0.4 |
| EXC24CB221U | 220 | | | 100 | 0.7 |
| EXC24CB102U | 1000 | | | 50 | 1.5 |

| Part Number | Impedance (Common mode) | | Rated Voltage (V) DC | Rated Current (mA) DC | DC Resistance (Ω)max. |
|-------------|-------------------------|---------------|-------------------------|--------------------------|--------------------------|
| | (Ω) at 100 MHz | Tolerance (%) | | | |
| EXC24CN601X | 600 | ±25 | 5 | 200 | 0.9 |

●Category Temperature Range -40 °C to +85 °C

Impedance Characteristics (Typical)

● EXC24CP121U

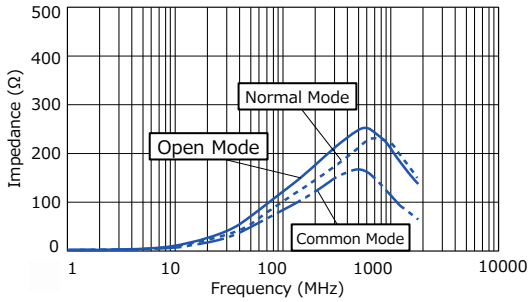

● EXC24CP221U

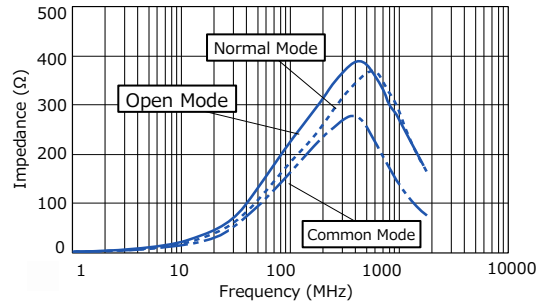

● EXC24CB221U

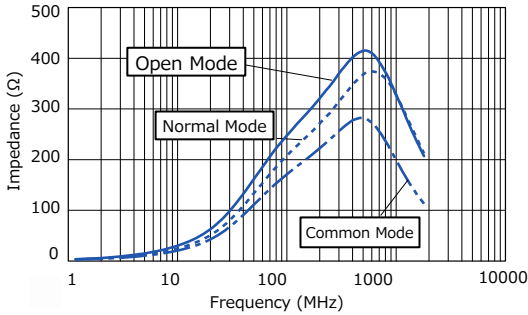

● EXC24CB102U

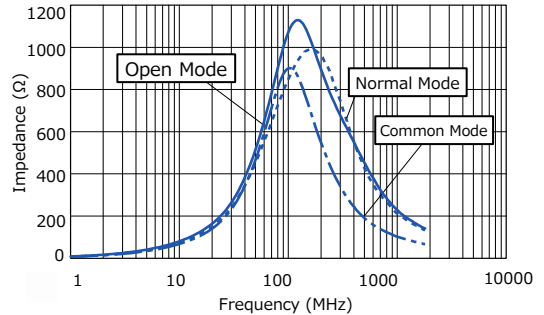

● Measurement Circuit

(A) Open Mode

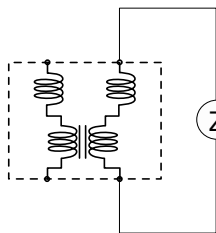

(B) Common Mode

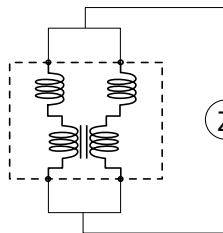

(C) Normal Mode

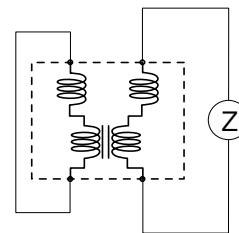

Impedance Characteristics (Typical)

● EXC24CN601X

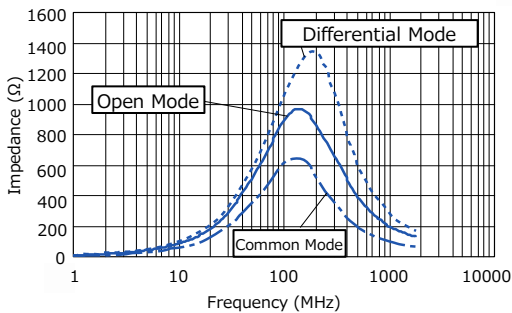

● Measurement Circuit

(A) Open Mode

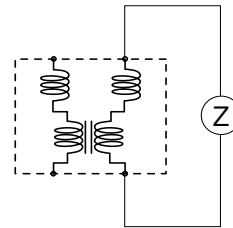

(B) Common Mode

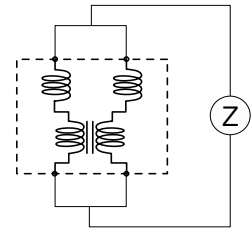

(C) Differential Mode

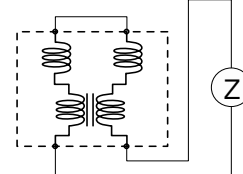

■ As for Packaging Methods, Land Pattern, Soldering Conditions and Safety Precautions, Please see Data Files

Packaging Methods (Taping)

● Standard Quantity

| Part Number | Size (inch) | Kind of Taping | Pitch(P ₁) | Quantity |
|----------------|-------------|-------------------------|------------------------|------------------|
| EXC14CP□□□U | 0302 | Embossed Carrier Taping | 2 mm | 10,000 pcs/ reel |
| EXC24CP/CB□□□U | 0504 | | 4 mm | 5,000 pcs/ reel |
| EXC24CN□□□X | 0504 | Pressed Carrier Taping | 2 mm | 10,000 pcs/ reel |

● Embossed Carrier Taping

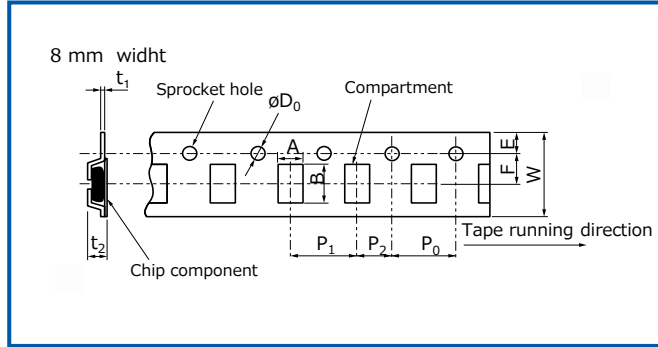

● Pressed Carrier Taping

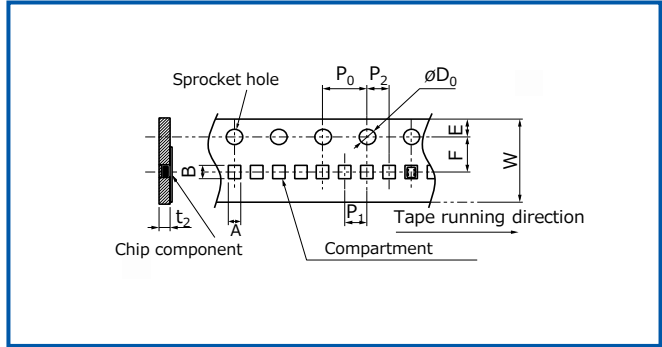

● Taping Reel

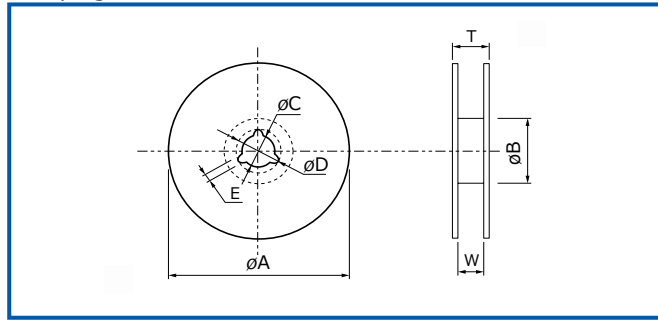

● Embossed Carrier Dimensions (mm)

| Part Number | A | B | W | F | E | P ₁ | P ₂ | P ₀ | øD ₀ | t ₁ | t ₂ |
|-------------|-----------|-----------|---------|-----------|-----------|----------------|----------------|----------------|----------------------------------|----------------|----------------|
| EXC14CP | 0.75±0.10 | 0.95±0.10 | 8.0±0.2 | 3.50±0.05 | 1.75±0.10 | 2.0±0.1 | 2.0±0.1 | 4.0±0.1 | 1.5 ^{+0.1} ₀ | 0.25±0.05 | 0.85±0.15 |
| EXC24CP/CB | 1.20±0.15 | 1.45±0.15 | 8.0±0.2 | 3.50±0.10 | 1.75±0.10 | 4.0±0.1 | 2.0±0.1 | 4.0±0.1 | 1.5 ^{+0.1} ₀ | 0.25±0.05 | 0.90±0.15 |

● Pressed Carrier Dimensions (mm)

| Part Number | A | B | W | F | E | P ₁ | P ₂ | P ₀ | øD ₀ | t ₂ |
|-------------|-----------|-----------|---------|---------|-----------|----------------|----------------|----------------|----------------------------------|----------------|
| EXC24CN | 1.14±0.10 | 1.38±0.15 | 8.0±0.2 | 3.5±0.1 | 1.75±0.10 | 2.0±0.1 | 2.0±0.1 | 4.0±0.1 | 1.5 ^{+0.1} ₀ | 0.68±0.10 |

● Standard Reel Dimensions (mm)

| Part Number | øA | øB | øC | øD | E | W | T |
|---------------|-----------|----------|----------|----------|---------|---------|----------|
| EXC14C/EXC24C | 180.0±3.0 | 60.0±1.0 | 13.0±0.5 | 21.0±0.8 | 2.0±0.5 | 9.0±0.3 | 11.4±1.5 |

Recommended Land Pattern Design

The diagram shows two rectangular pads on a PCB. Dimension A is the total height of the pads. Dimension B is the total width between the inner edges of the pads. Dimension C is the distance between the top edges of the pads. Dimension D is the height of each pad. Dimension E is the distance from the center of each pad to the nearest edge. Dimension F is the distance between the centers of the two pads.

| Part Number | Dimensions (mm) | | | | | |
|-------------------------------|-----------------|------|------|--------------|------|------|
| | A | B | C | D | E | F |
| EXC14CP | 0.80 to 1.00 | 0.80 | 0.30 | 0.25 to 0.35 | 0.30 | 0.20 |
| EXC24CP EXC24CB EXC24CN | 1.50 to 1.90 | 1.10 | 0.50 | 0.50 to 0.70 | 0.40 | 0.30 |

Recommended Soldering Conditions

Recommendations and precautions are described below

● **Recommended soldering conditions for reflow**

- Reflow soldering shall be performed a maximum of two times.
- Please contact us for additional information when used in conditions other than those specified.
- Please measure the temperature of the terminals and study every kind of solder and printed circuit board for solderability before actual use.

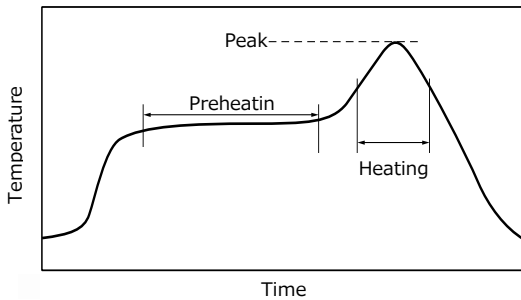

● **Flow soldering**

- We do not recommend flow soldering, because flow soldering may cause bridges between the electrodes.

For soldering (Example : Sn-37Pb)

| | Temperature | Time |
|--------------|------------------|---------------|
| Preheating | 140 °C to 160 °C | 60 s to 120 s |
| Main heating | Above 200 °C | 30 s to 40 s |
| Peak | 235 ± 10 °C | max. 10 s |

For lead-free soldering (Example :Sn-3Ag-0.5Cu)

| | Temperature | Time |
|--------------|------------------|---------------|
| Preheating | 150 °C to 170 °C | 60 s to 120 s |
| Main heating | Above 230 °C | 30 s to 40 s |
| Peak | max. 260 °C | max. 10 s |

《Repair with hand soldering》

- Preheat with a blast of hot air or similar method. Use a soldering iron with a tip temperature of 350 °C or less. Solder each electrode for 3 seconds or less.
- Never touch this product with the tip of a soldering iron.

| Performance | | |
|------------------------------|----------------------------|---|
| Test Item | Performance Requirements | Test Conditions Resistance |
| Resistance | Within Specified Tolerance | 25 °C |
| Overload | – | Rated Voltage |
| Resistance to Soldering Heat | ±30 % (Impedance Change) | 260 °C, 10 s |
| Rapid Change of Temperature | ±30 % (Impedance Change) | –40 °C (30 min.) / +85 °C (30 min.), 200 cycles |
| High Temperature Exposure | ±30 % (Impedance Change) | 85 °C , 500 h |
| Damp Heat, Steady State | ±30 % (Impedance Change) | 60 °C, 95 %RH, 500 h |
| Load Life in Humidity | ±30 % (Impedance Change) | 60 °C, 95 %RH, Rated Current, 500 h |

Safety Precautions

(Common mode Noise Filters/Array, Common mode Noise Filters/Array with ESD Suppressor, 2 mode Noise Filters)

- When using our products, no matter what sort of equipment they might be used for, be sure to make a written agreement on the specifications with us in advance. The design and specifications in this catalog are subject to change without prior notice.
- Do not use the products beyond the specifications described in this catalog.
- This catalog explains the quality and performance of the products as individual components. Before use, check and evaluate their operations when installed in your products under the actual conditions for use.
- Install the following systems for a failsafe design to ensure safety if these products are to be used in equipment where a defect in these products may cause the loss of human life or other significant damage, such as damage to vehicles (automobile, train, vessel), traffic lights, medical equipment, aerospace equipment, electric heating appliances, combustion/gas equipment, rotating equipment, and disaster/crime prevention equipment.
- * Systems equipped with a protection circuit and a protection device.
- * Systems equipped with a redundant circuit or other system to prevent an unsafe status in the event of a single fault.
- * Systems equipped with an arresting the spread of fire or preventing glitch.

(1) Precautions for use

- These products are designed and manufactured for general and standard use in general electronic equipment. (e.g. AV equipment, home electric appliances, office equipment, information and communication equipment) For applications in which special quality and reliability are required, or if the failure or malfunction of the products may directly jeopardize life or cause threat of personal injury (such as for aircraft and aerospace equipment, traffic and transport equipment, combustion equipment, medical equipment, accident prevention and anti-theft devices, and safety equipment), please be sure to consult with our sales representative in advance and to exchange product specifications which conform to such applications.
- These products are not intended for use in the following special conditions. Before using the products, carefully check the effects on their quality and performance, and determine whether or not they can be used.
 1. In liquid, such as water, oil, chemicals, or organic solvent.
 2. In direct sunlight, outdoors, or in dust.
 3. In salty air or air with a high concentration of corrosive gas, such as Cl₂, H₂S, NH₃, SO₂, or NO_x.
 4. Electric Static Discharge (ESD) Environment.
These components are sensitive to static electricity and can be damaged under static shock (ESD). Please take measures to avoid any of these environments.
Smaller components are more sensitive to ESD environment.
 5. Electromagnetic and Radioactive Environment.
Avoid any environment where strong electromagnetic waves and radiation exist.
 6. In an environment where these products cause dew condensation.
 7. Sealing or coating of these products or a printed circuit board on which these products are mounted, with resin or other materials.
- These products generate Joule heat when energized. Carefully position these products so that their heat will not affect the other components.
- Carefully position these products so that their temperatures will not exceed the category temperature range due to the effects of neighboring heat-generating components. Do not mount or place heat-generating components or inflammables, such as vinyl-coated wires, near these products.
- Note that non-cleaning solder, halogen-based highly active flux, or water-soluble flux may deteriorate the performance or reliability of the products.
- Carefully select a flux cleaning agent for use after soldering. An unsuitable agent may deteriorate the performance or reliability. In particular, when using water or a water-soluble cleaning agent, be careful not to leave water residues. Otherwise, the insulation performance may be deteriorated.
- Do not apply flux to these products after soldering. The activity of flux may be a cause of failures in these products.
- Refer to the recommended soldering conditions and set the soldering condition. High peak temperature or long heating time may impair the performance or the reliability of these products.

- Recommended soldering condition is for the guideline for ensuring the basic characteristics of the products, not for the stable soldering conditions. Conditions for proper soldering should be set up according to individual conditions.
- Do not reuse any products after removal from mounting boards.
- Do not drop these products. If these products are dropped, do not use them. Such products may have received mechanical or electrical damage.
- If any doubt or concern to the safety on these products arise, make sure to inform us immediately and conduct technical examinations at your side.

(2) Precautions for storage

The performance of these products, including the solderability, is guaranteed for a year from the date of arrival at your company, provided that they remain packed as they were when delivered and stored at a temperature of -5 °C to +40 °C and a relative humidity of 15 % to 75 %.

Even within the above guarantee periods, do not store these products in the following conditions. Otherwise, their electrical performance and/or solderability may be deteriorated, and the packaging materials (e.g. taping materials) may be deformed or deteriorated, resulting in mounting failures.

1. In salty air or in air with a high concentration of corrosive gas, such as Cl₂, H₂S, NH₃, SO₂, or NO_x.
2. In direct sunlight.

(3) Precaution specific to this product

1. Use rosin-based flux or halogen-free flux.
2. For cleaning, use an alcohol-based cleaning agent. Before using any other type, consult with our sales person in advance.
3. Mounting of the suppressors with excessive or insufficient wetting amount of solder may affect the connection reliability or the performance of the suppressors. Carefully check the effects and apply a proper amount of solder for use.
4. Do not apply shock to Filters or pinch them with a hard tool (e.g. pliers and tweezers). Otherwise, their bodies may be chipped, affecting their performance. Excessive mechanical stress may damage the filters. Handle with care.
7. Avoid excessive bending of printed circuit boards in order to protect the suppressors from abnormal stress.
8. Do not immerse the suppressors in solvent for a long time. Before using solvent, carefully check the effects of immersion.
9. Do not apply excessive tension to the terminals.

<Package markings>

Package markings include the product number, quantity, and country of origin.

In principle, the country of origin should be indicated in English.

ESD Suppressor

Type: **EZAEG**

EZAEG2A, 3A



Features

- ESD protection of high-speed data lines
- Low capacitance 1005(0402) size : 0.05 pF, 1608(0603) size : 0.10 pF
- Good ESD suppression characteristics
- Good ESD withstanding
- RoHS compliant

Recommended Applications

- Smart phones, Mobile phones, RF Modules, NFC and GPS
- ESD suppression of high-speed differential data line such as Antena circuit, HDMI, SATA, USB, Display Port

Explanation of Part Numbers

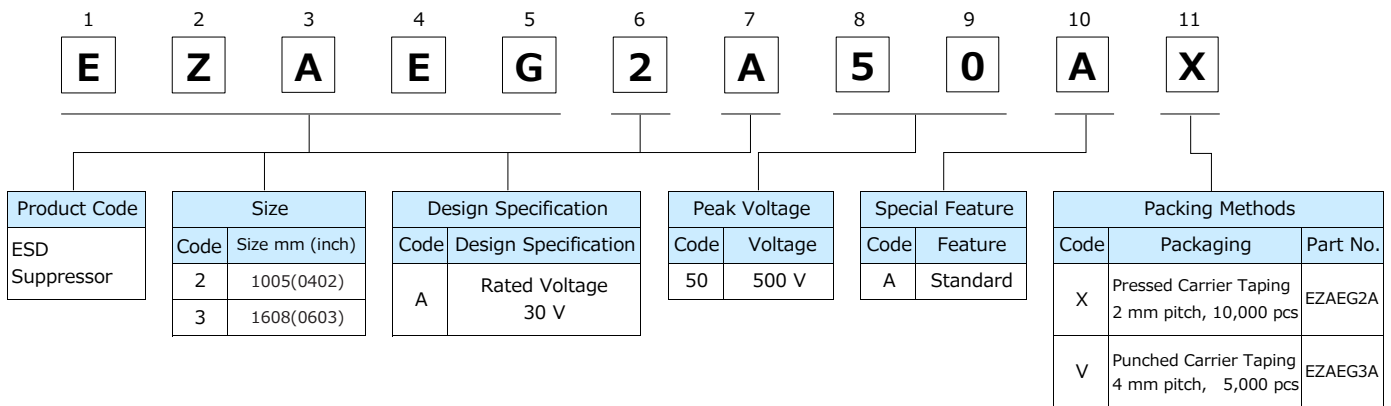

Construction

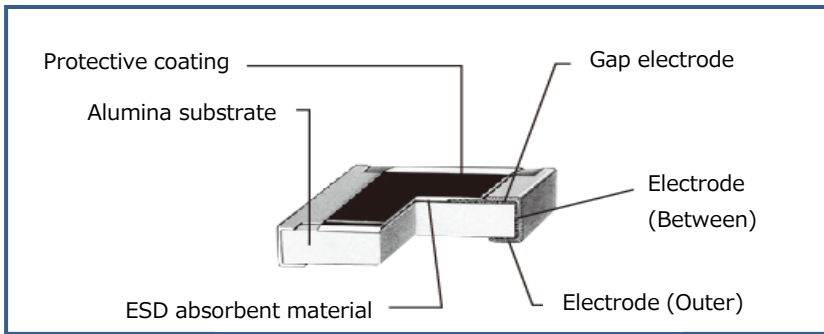

Circuit Configuration

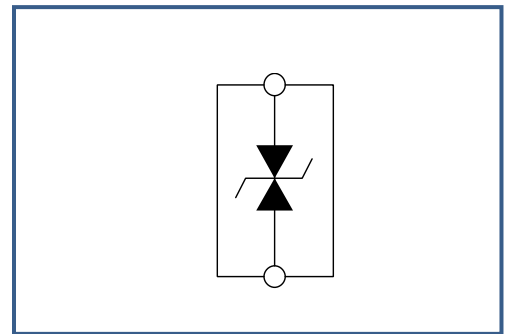

Dimensions in mm (not to scale)

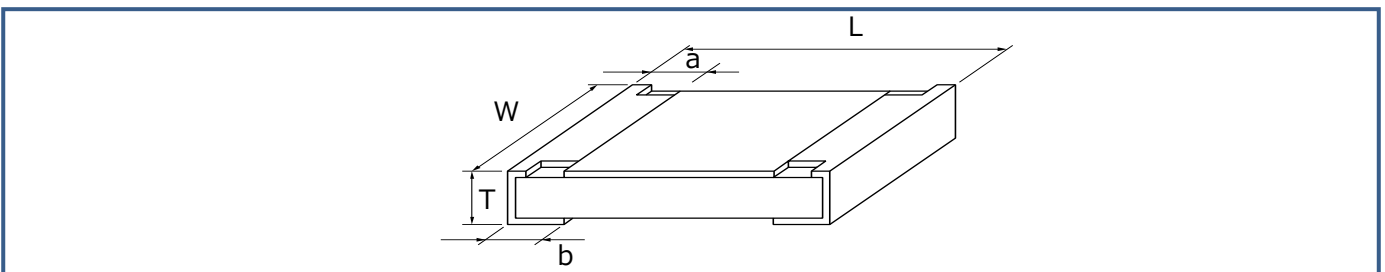

| Part No. (inch size) | Dimensions(mm) | | | | | Mass (Weight) (g/1000 pcs) |
|-------------------------|----------------|-----------|-----------|-----------|-----------|----------------------------------|
| | L | W | a | b | T | |
| EZAEG2A (0402) | 1.00±0.10 | 0.50±0.05 | 0.20±0.10 | 0.25±0.10 | 0.38±0.05 | 0.6 |
| EZAEG3A (0603) | 1.60±0.15 | 0.80±0.15 | 0.30±0.20 | 0.30±0.20 | 0.50±0.10 | 2.2 |

Ratings

| Part Number | Capacitance ⁽¹⁾ | Rated Voltage | Category Temperature Range |
|-------------|----------------------------|---------------|----------------------------|
| EZAEG2A50AX | 0.05+0.05/-0.04 pF | 30 V max. | -55 to +125 °C |
| EZAEG3A50AV | 0.10+0.10/-0.08 pF | | |

(1) Capacitance = The capacitance value shall be measured under the conditions specified below.
 Frequency : 1 MHz ± 10 %, Voltage : 1 Vrms ± 0.2 Vrms, Temperature : 25 °C ± 2 °C

Performance

| Test Item | Performance Requirements | Test Conditions |
|------------------------------|-------------------------------|--|
| Peak Voltage | 500 V max. | IEC61000-4-2, contact discharge 8 kV, Peak voltage value |
| Clamping Voltage | 100 V max. | IEC61000-4-2, contact discharge 8 kV, voltage at 30 ns after initiation of pulse |
| Leakage Current | 1 µA max. | Current at Rated voltage (DC 30 V) |
| ESD withstanding | Leakage current 10 µA max. | IEC61000-4-2, contact discharge 8 kV, +/- 10 times |
| Rapid Change of Temperature | | -55 °C (30 min.) / +125 °C (30 min.), 100 cycles |
| Load Life in Humidity | | 60 °C, 90 % to 95 %RH, Rated voltage, 1000 h |
| Endurance at 85 °C | | 85 °C, Rated voltage, 1000 h |
| Resistance to Soldering Heat | | 270 °C, 10 s |

Frequency Characteristics

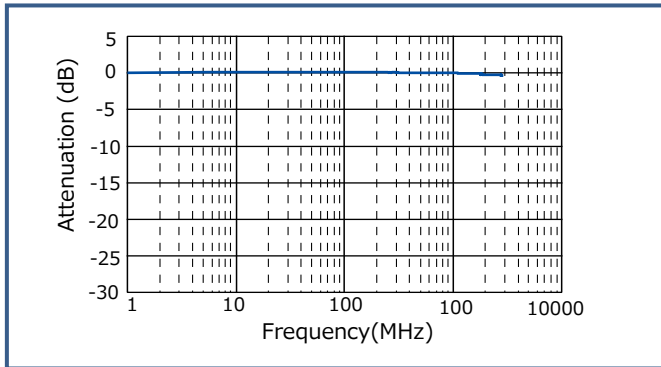

ESD Suppression Voltage Waveform

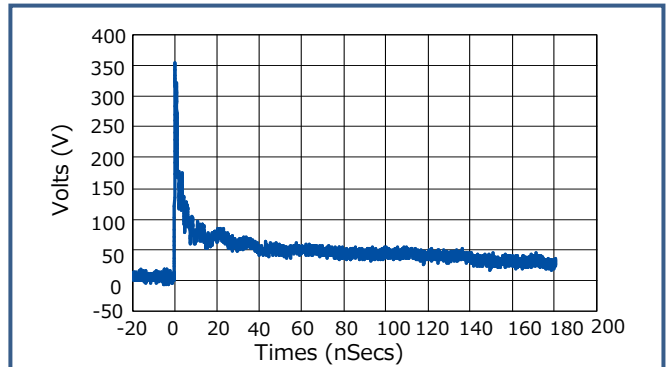

Typical Circuits Requiring Protection

● HDMI circuit

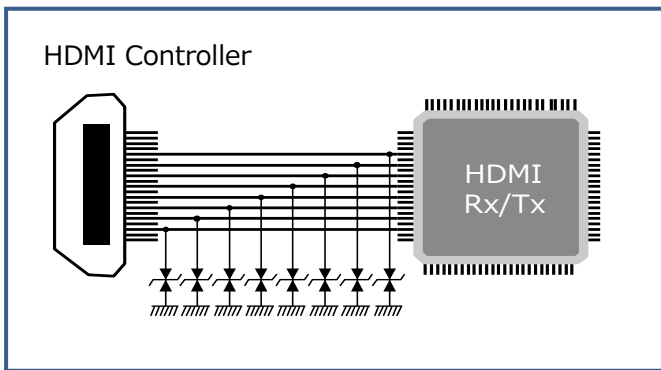

● Antenna circuit

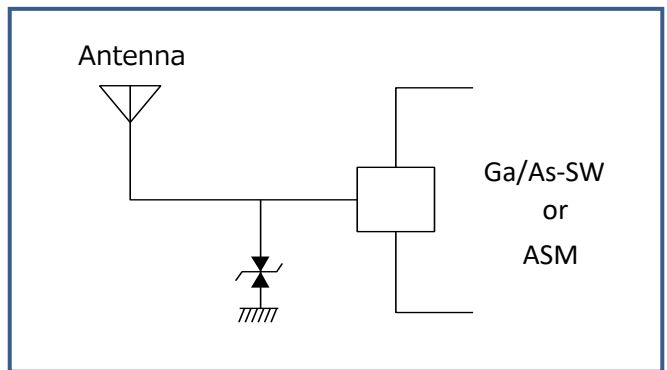

Recommended Land Pattern

Recommended land pattern design for ESD Suppressor is shown below.

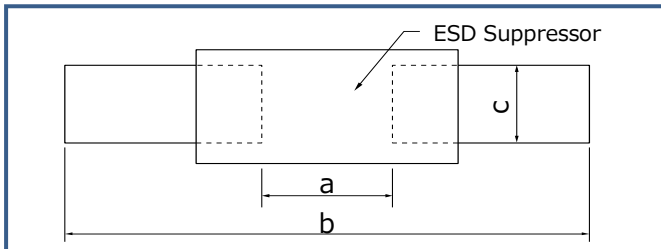

| Part Number | Dimensions(mm) | | |
|-------------|----------------|------------|------------|
| | a | b | c |
| EZAEG2A | 0.5 to 0.6 | 1.4 to 1.6 | 0.4 to 0.6 |
| EZAEG3A | 0.7 to 0.9 | 2.0 to 2.2 | 0.8 to 1.0 |

■ As for Packaging Methods, Soldering Conditions and Safety Precautions,
 Please see Data Files

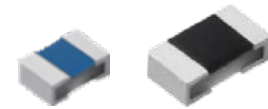

ESD Suppressor

Type: **EZAEG**

EZAEG1N, 2N

Features

- Good ESD withstanding (IEC61000-4-2 15 kV contact/air Discharge)
- ESD protection of high-speed data lines
- Low capacitance 0603(0201) size : 0.04 pF, 1005(0402) size : 0.05 pF
- Good ESD suppression characteristics
- RoHS compliant

Recommended Applications

- Smart phones, Mobile phones, RF Modules, NFC and GPS
- ESD suppression of high-speed differential data line such as Antena circuit, HDMI, SATA, USB, Display Port

Explanation of Part Numbers

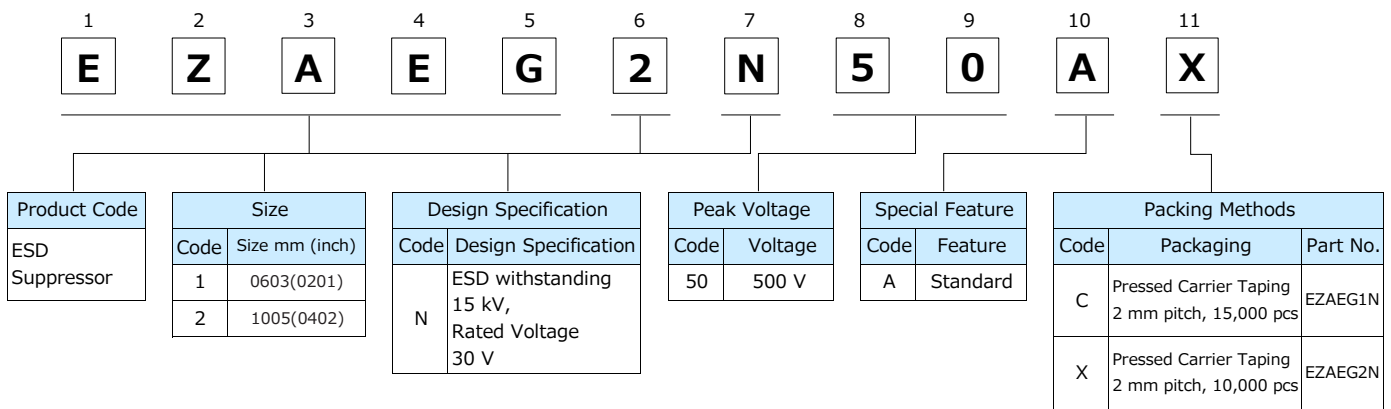

Construction

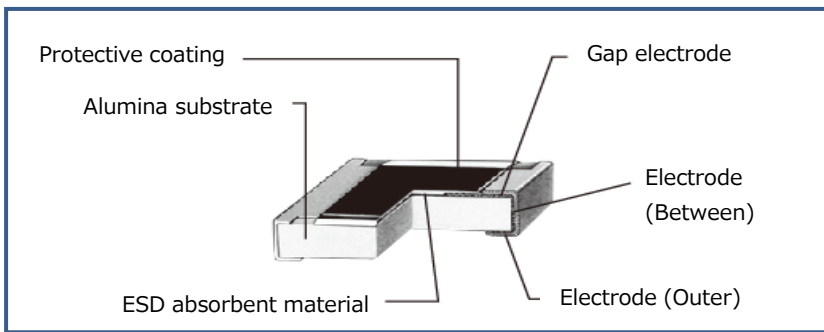

Circuit Configuration

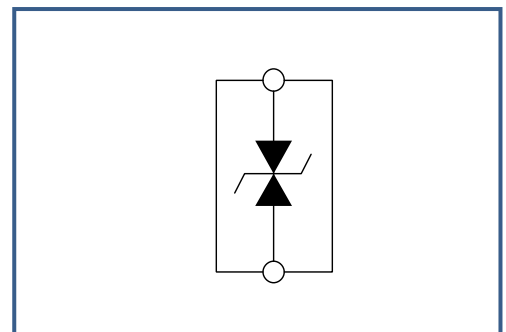

Dimensions in mm (not to scale)

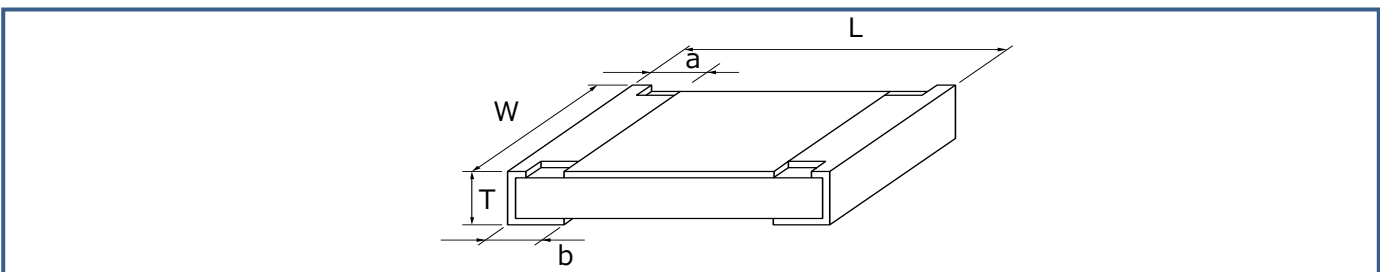

| Part No. (inch size) | Dimensions(mm) | | | | | Mass (Weight) (g/1000 pcs) |
|-------------------------|----------------|-----------|-----------|-----------|-----------|----------------------------------|
| | L | W | a | b | T | |
| EZAEG1N (0201) | 0.60±0.03 | 0.30±0.03 | 0.15±0.10 | 0.15±0.10 | 0.23±0.03 | 0.12 |
| EZAEG2N (0402) | 1.00±0.10 | 0.50±0.05 | 0.20±0.10 | 0.27±0.10 | 0.38±0.05 | 0.60 |

Ratings

| Part Number | Capacitance ⁽¹⁾ | Rated Voltage | Category Temperature Range |
|-------------|----------------------------|---------------|----------------------------|
| EZAEG1N50AC | 0.04+0.04/-0.03 pF | 30 V max. | -55 °C to +125 °C |
| EZAEG2N50AX | 0.05+0.05/-0.04 pF | | |

(1) Capacitance = The capacitance value shall be measured under the conditions specified below.
 Frequency : 1 MHz ± 10 %, Voltage : 1 Vrms ± 0.2 Vrms, Temperature : 25 °C ± 2 °C

Performance

| Test Item | Performance Requirements | Test Conditions |
|------------------------------|-------------------------------|--|
| Peak Voltage | 500 V max. | IEC61000-4-2, contact discharge 8 kV, Peak voltage value |
| Clamping Voltage | 100 V max. | IEC61000-4-2, contact discharge 8 kV, voltage at 30 ns after initiation of pulse |
| Leakage Current | 1 µA max. | Current at Rated voltage (DC 30 V) |
| ESD withstanding | Leakage current 10 µA max. | IEC61000-4-2, contact discharge 15 kV or air discharge 15 kV, +/- 50 times |
| Rapid Change of Temperature | | -55 °C (30 min.) / +125 °C (30 min.), 100 cycles |
| Load Life in Humidity | | 60 °C, 90 % to 95 %RH, Rated voltage, 1000 h |
| Endurance at 85 °C | | 85 °C, Rated voltage, 1000 h |
| Resistance to Soldering Heat | | 270 °C, 10 s |

Frequency Characteristics

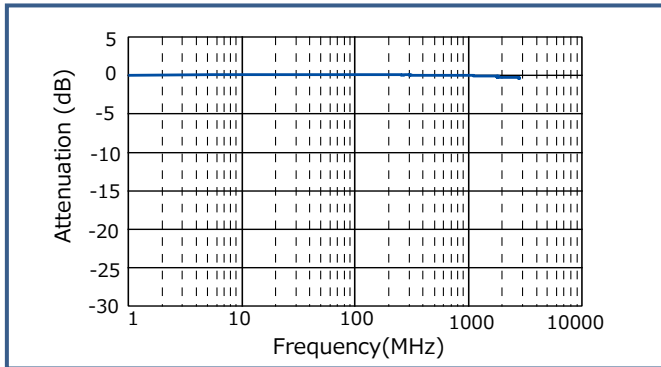

ESD Suppression Voltage Waveform

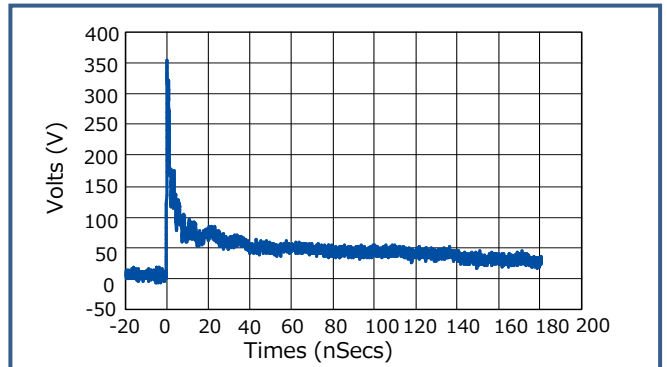

Typical Circuits Requiring Protection

● HDMI circuit

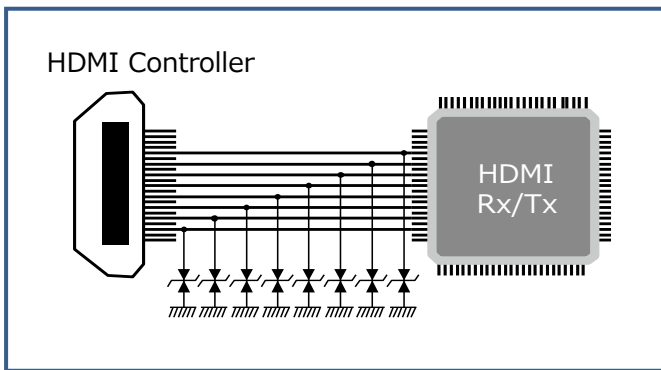

● Antenna circuit

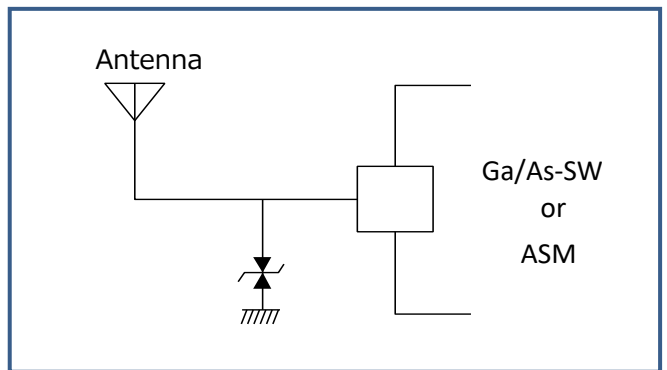

Recommended Land Pattern

Recommended land pattern design for ESD Suppressor is shown below.

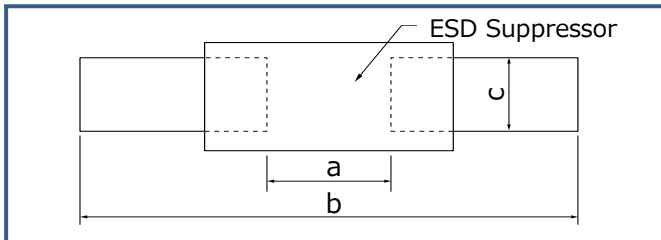

| Part Number | Dimensions(mm) | | |
|-------------|----------------|------------|--------------|
| | a | b | c |
| EZAEG1N | 0.3 to 0.4 | 0.8 to 0.9 | 0.25 to 0.35 |
| EZAEG2N | 0.5 to 0.6 | 1.4 to 1.6 | 0.40 to 0.60 |

■ As for Packaging Methods, Soldering Conditions and Safety Precautions,
 Please see Data Files

ESD Suppressor Array

Type: **EZAEGCA**

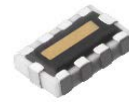

Features

- 4 ESD suppressors in one package
- ESD protection of high-speed data lines
- Low capacitance (0.25 pF)
- Good ESD suppression characteristics
- Good ESD withstanding
- RoHS compliant

Recommended Applications

- AV equipment (LCD-TV, DVD/Blu-ray drives) , Information equipment (PCs, HDD)
- ESD suppression of high-speed differential data line such as USB3.0, HDMI, Display Port

Explanation of Part Numbers

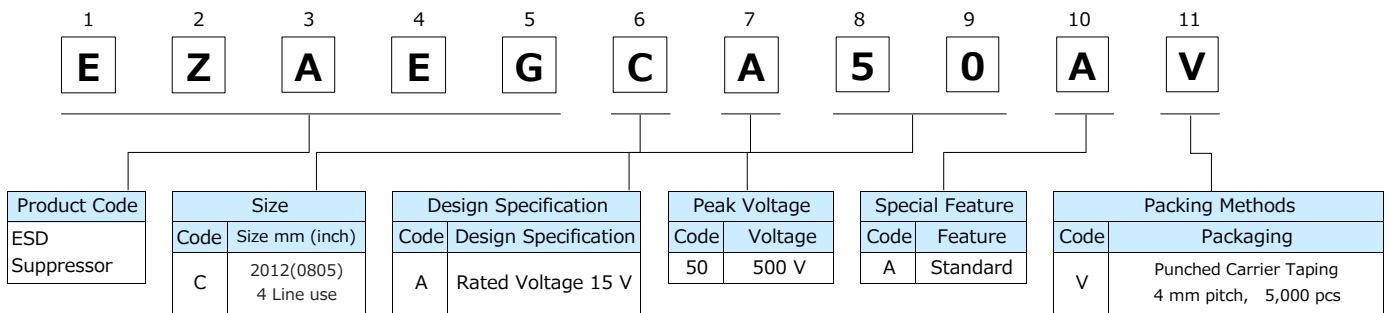

Construction

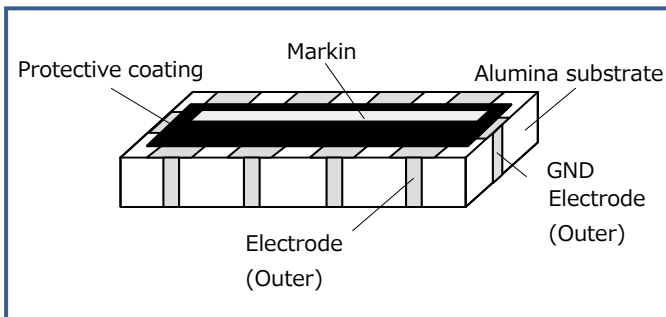

Circuit Configuration

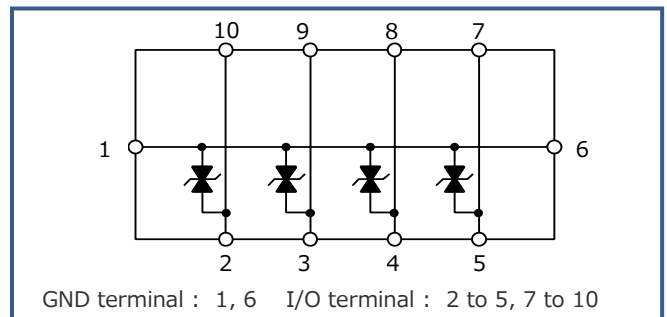

Dimensions in mm (not to scale)

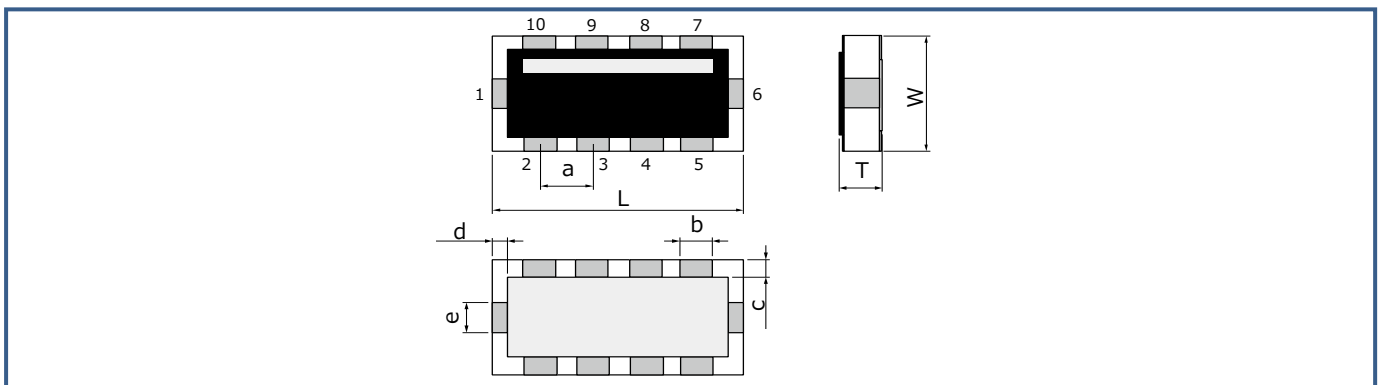

| Part No. (inch size) | Dimensions(mm) | | | | | | | | Mass (Weight) (g/1000 pcs) |
|-------------------------|----------------|-----------|-------|-----------|-----------|-----------|-----------|-----------|----------------------------------|
| | L | W | a | b | c | d | e | T | |
| EZAEGCA50AV (0805) | 2.0±0.1 | 1.25±0.10 | (0.5) | 0.30±0.15 | 0.25±0.15 | 0.20±0.15 | 0.35±0.15 | 0.50±0.10 | 4 |

()Reference

Ratings

| Part Number | Capacitance ⁽¹⁾ | Rated Voltage ⁽²⁾ | Rated Current ⁽³⁾ | Category Temperature Range |
|-------------|----------------------------|------------------------------|------------------------------|----------------------------|
| EZAEGCA50AV | 0.25+0.05/-0.10 pF | 15 V max. | 100 mA max. | -55 °C to +125 °C |

- (1) Capacitance = The capacitance value shall be measured under the conditions specified below.
Frequency : 1 MHz ± 10 %, Voltage : 1 Vrms ± 0.2 Vrms, Temperature : 25 °C ± 2 °C
- (2) Rated voltage between I/O terminal and GND.
- (3) Rated current between input terminal and output terminal.

Performance

| Test Item | Performance Requirements | Test Conditions |
|------------------------------|-------------------------------|--|
| Peak Voltage | 500 V max. | IEC61000-4-2, contact discharge 8 kV, Peak voltage value |
| Clamping Voltage | 100 V max. | IEC61000-4-2, contact discharge 8 kV, voltage at 30 ns after initiation of pulse |
| Leakage Current | 1 µA max. | Current at Rated voltage (DC 15 V) |
| ESD withstanding | Leakage current 10 µA max. | IEC61000-4-2, contact discharge 8 kV, +/- 10 times |
| Rapid Change of Temperature | | -55 °C (30 min.) / +125 °C (30 min.), 100 cycles |
| Load Life in Humidity | | 60 °C, 90 % to 95 %RH, Rated voltage, 1000 h |
| Endurance at 85 °C | | 85 °C, Rated voltage, 1000 h |
| Resistance to Soldering Heat | | 270 °C, 10 s |

Frequency Characteristics

- HDMI circuit

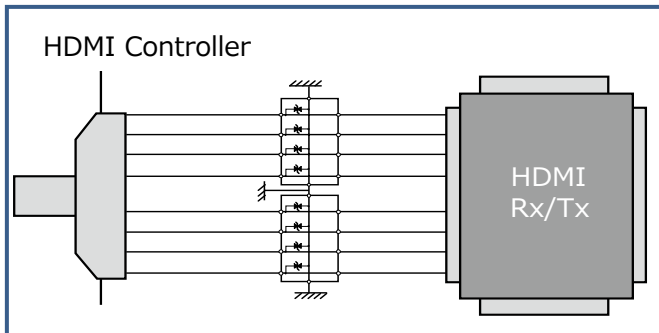

ESD Suppression Voltage Waveform

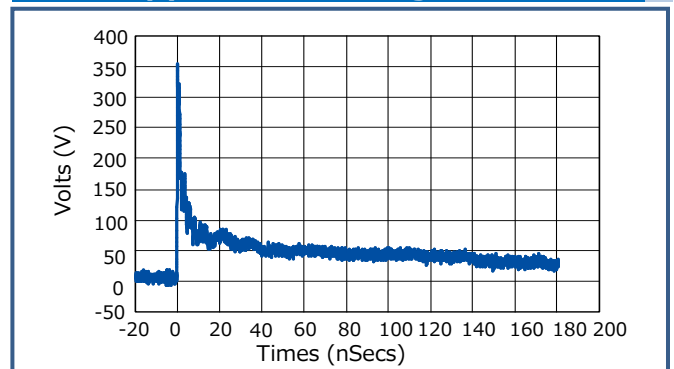

Recommended Land Pattern

Recommended land pattern design for ESD Suppressor Array is shown below.

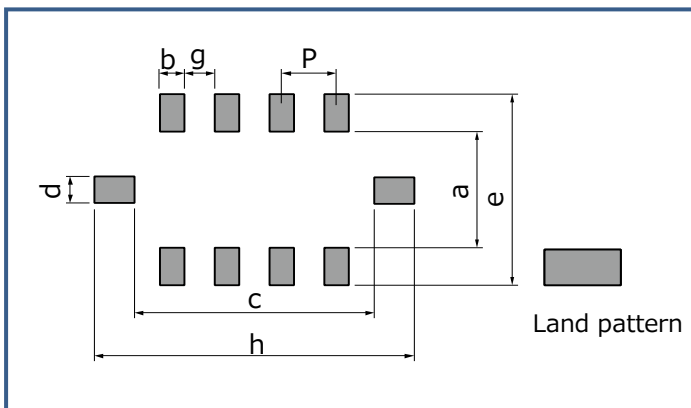

| Dimensions(mm) | | | |
|----------------|------|------|------|
| a | b | c | d |
| 0.75 | 0.25 | 1.70 | 0.35 |
| Dimensions(mm) | | | |
| e | h | g | P |
| 1.85 | 2.60 | 0.25 | 0.50 |

- As for Packaging Methods, Soldering Conditions and Safety Precautions, Please see Data Files

ESD Suppressor, High Withstanding Type

Type: **EZAEG**

EZAEG 3W



Features

- Excellent ESD withstanding (Conforms with automotive ESD standards (ISO10605, air discharge 25 kV))
- Low capacitance 1608(0603) size : 0.10 pF
- High rated voltage (DC 50 V) contributes to reduce the risk of communication error
- AEC-Q200 compliant
- RoHS compliant

Recommended Applications

- High speed data line for automotive (CAN, Ethernet, USB, LVDS)
- Automotive Antenna
- Amusement equipment

Explanation of Part Numbers

| | | | | | | | | | | | |
|---------------------|-------------|----------------|-----------------------------|---|---------------------|----------|------------------------|----------|------------------------|---|----------|
| 1 | 2 | 3 | 4 | 5 | 6 | 7 | 8 | 9 | 10 | 11 | |
| E | Z | A | E | G | 3 | W | 1 | 1 | A | V | |
| Product Code | Size | | Design Specification | | Peak Voltage | | Special Feature | | Packing Methods | | |
| ESD Suppressor | Code | Size mm (inch) | Code | Design Specification | Code | Voltage | Code | Feature | Code | Packaging | Part No. |
| | 3 | 1608(0603) | W | High with standing type Rated voltage 50 V | 11 | 1000 V | A | Standard | V | Punched Carrier Taping 4 mm pitch, 4,000 pcs | EZAEG3W |

Construction

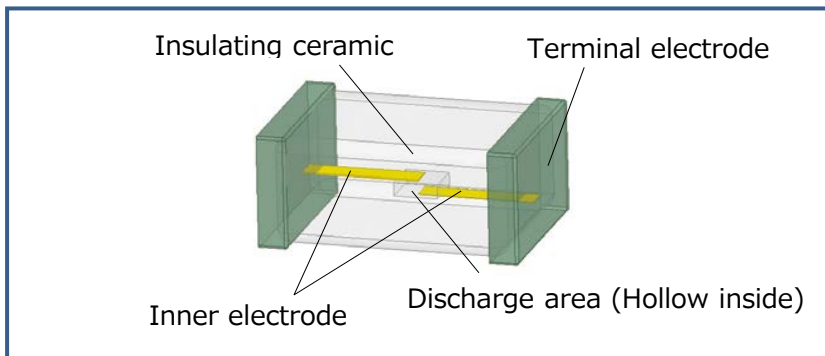

Circuit Configuration

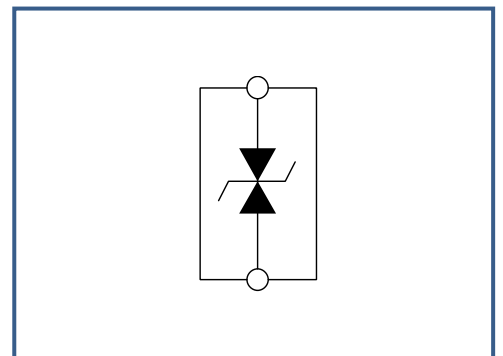

Dimensions in mm (not to scale)

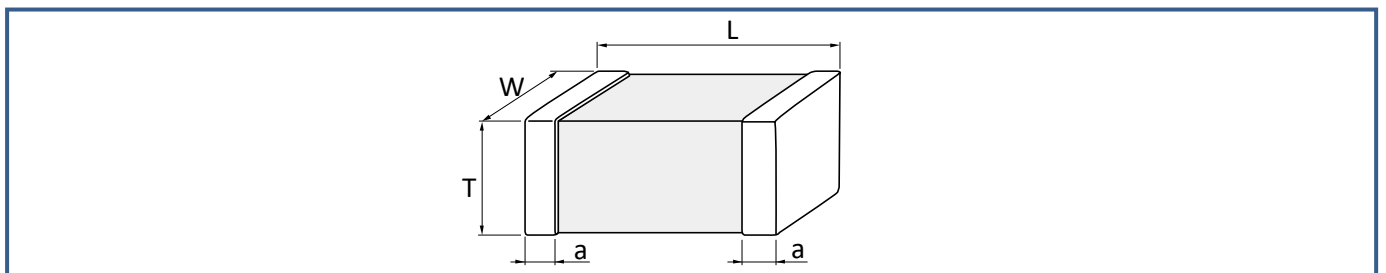

| Part No. (inch size) | Dimensions(mm) | | | | Mass (Weight) (g/1000 pcs) |
|-------------------------|----------------|-----------|-----------|-----------|----------------------------------|
| | L | W | T | a | |
| EZAEG3W (0603) | 1.60±0.15 | 0.80±0.15 | 0.80±0.15 | 0.30±0.20 | 3.8 |

Ratings

| Part Number | Capacitance ⁽¹⁾ | Rated Voltage | Category Temperature Range |
|-------------|----------------------------|---------------|----------------------------|
| EZAEG3W11AV | 0.10+0.10/-0.08 pF | 50 V max. | -55 °C to +125 °C |

(1) Capacitance = The capacitance value shall be measured under the conditions specified below.
 Frequency : 1 MHz ± 10 %, Voltage : 1 Vrms ± 0.2 Vrms, Temperature : 25 °C ± 2 °C

Performance

| Test Item | Performance Requirements | Test Conditions |
|------------------------------|-------------------------------|---|
| Peak Voltage | 1000 V max. | ISO10605, air discharge 15 kV, Peak voltage value |
| Leakage Current | 1 µA max. | Current at Rated voltage (DC 50 V) |
| ESD withstanding | Leakage current 10 µA max. | ISO10605, air discharge 25 kV, +/- 50 times |
| Rapid Change of Temperature | | -55 °C (30 min.) / +125 °C (30 min.), 100 cycles |
| Load Life in Humidity | | 85 °C, 85 %RH, Rated voltage, 1000 h |
| Endurance at 125 °C | | 125 °C, Rated voltage, 1000 h |
| Resistance to Soldering Heat | | 270 °C, 10 s |

Frequency Characteristics

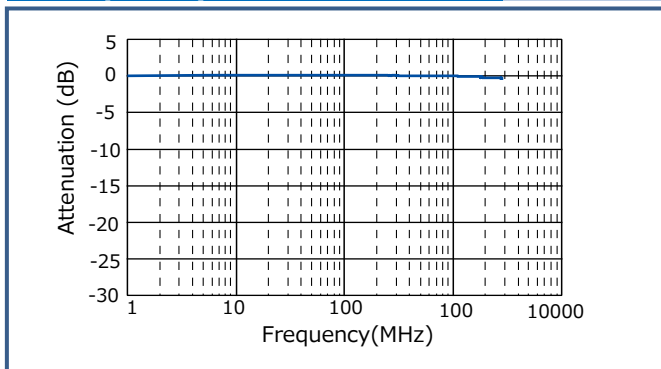

ESD Suppression Voltage Waveform

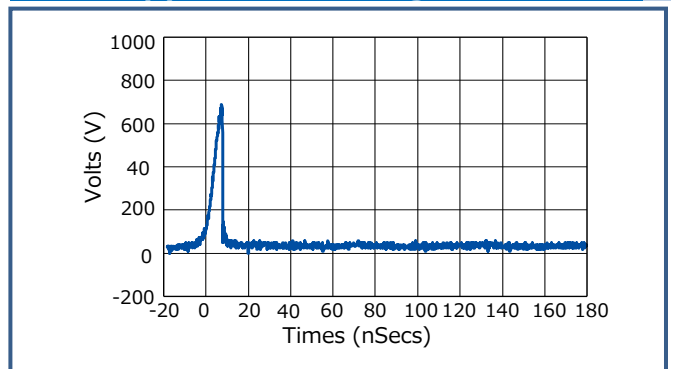

Typical Circuits Requiring Protection

- Automotive network (CAN, Ethernet)

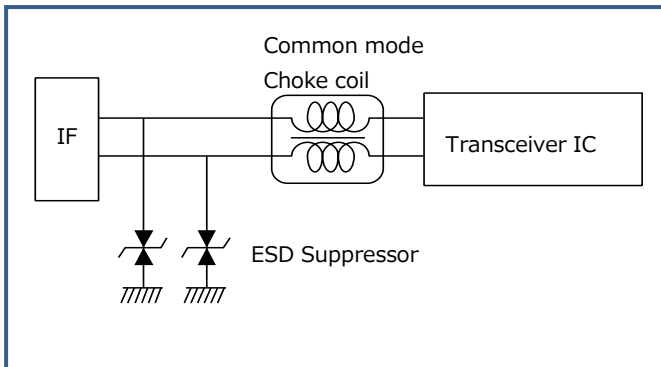

- Automotive antenna

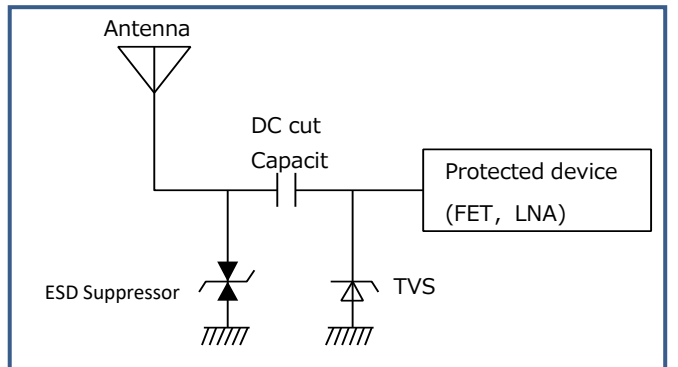

Recommended Land Pattern

Recommended land pattern design for ESD Suppressor is shown below.

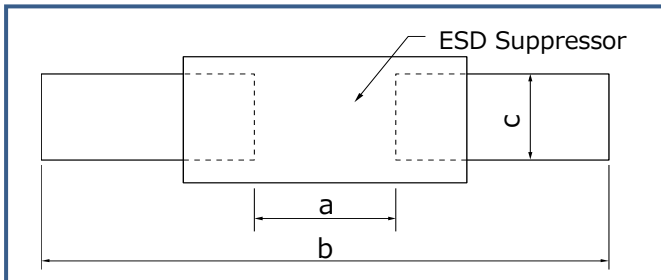

| Part Number | Dimensions(mm) | | |
|-------------|----------------|------------|------------|
| | a | b | c |
| EZAEG3W | 0.8 to 1.0 | 2.0 to 2.6 | 0.8 to 1.0 |

■ As for Packaging Methods, Soldering Conditions and Safety Precautions,
 Please see Data Files

Packaging Methods (Taping)

● Standard Quantity

| Part Number | Size (inch) | Type | Kind of Taping | Pitch (P ₁) | Quantity |
|-------------|-------------|------------------|------------------------|-------------------------|-------------------|
| EZAEG1N | 0201 | Single | Pressed Carrier Taping | 2 mm | 15,000 pcs / reel |
| EZAEG2A,2N | 0402 | | | | 10,000 pcs / reel |
| EZAEG3A | 0603 | | Array | Punched Carrier Taping | 4 mm |
| EZAEG3W | 0603 | 4,000 pcs / reel | | | |
| EZAEGCA | 0805 | | | | |

● Carrier Taping

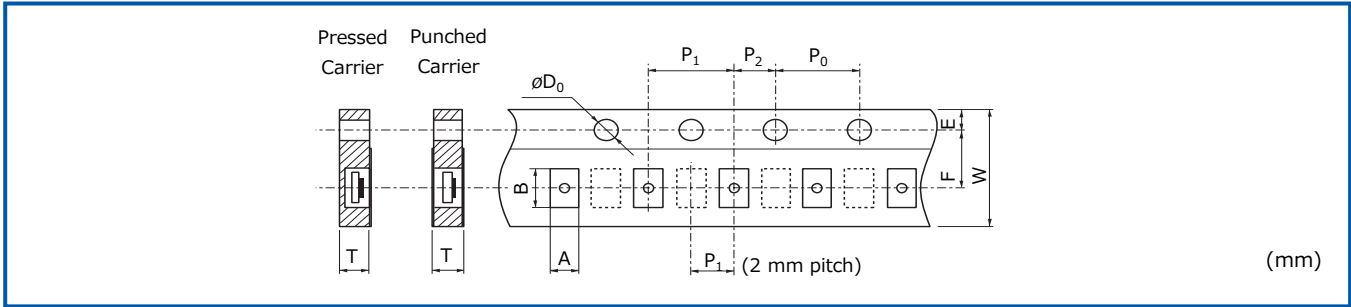

| Part Number | Size(inch) | A | B | W | F | E | P ₁ | P ₂ | P ₀ | øD ₀ | T |
|-------------|------------|-----------|-----------|-----------|-----------|-----------|----------------|----------------|----------------|----------------------------------|-----------|
| EZAEG1N | 0201 | 0.38±0.05 | 0.68±0.05 | 8.00±0.20 | 3.50±0.05 | 1.75±0.10 | 2.00±0.10 | 2.00±0.05 | 4.00±0.10 | 1.5 ^{+0.1} ₀ | 0.42±0.05 |
| EZAEG2A,2N | 0402 | 0.70±0.05 | 1.20±0.05 | | | | 0.60±0.05 | | | | |
| EZAEG3A | 0603 | 1.10±0.10 | 1.90±0.10 | 8.00±0.20 | 3.50±0.05 | 1.75±0.10 | 4.00±0.10 | 2.00±0.05 | 4.00±0.10 | 1.5 ^{+0.1} ₀ | 0.70±0.05 |
| EZAEG3W | 0603 | 0.91±0.10 | 1.82±0.10 | | | | | | | | 1.08±0.10 |
| EZAEGCA | 0805 | 1.55±0.15 | 2.30±0.20 | | | | 0.85±0.05 | | | | |

● Taping Reel

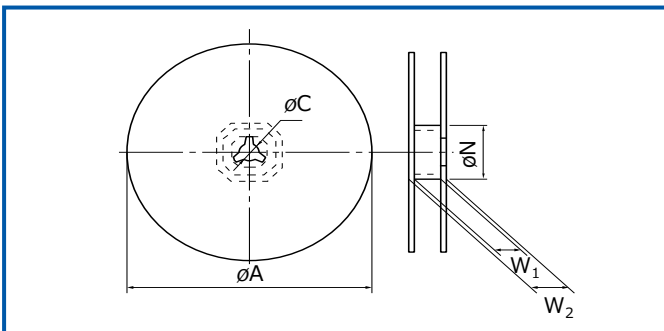

| Dimensions(mm) | | |
|------------------------------------|-----------------------------------|----------|
| øA | øN | øC |
| 180.0 ⁰ _{-1.5} | 60.0 ^{+1.0} ₀ | 13.0±0.2 |
| Dimensions(mm) | | |
| W ₁ | W ₂ | |
| 9.0 ^{+1.0} ₀ | 11.4±1.0 | |

Recommended Soldering Conditions

Recommendations and precautions are described below

● Recommended soldering conditions for reflow

- Reflow soldering shall be performed a maximum of two times.
- Please contact us for additional information when used in conditions other than those specified.
- Please measure the temperature of the terminals and study every kind of solder and printed circuit board for solderability before actual use.

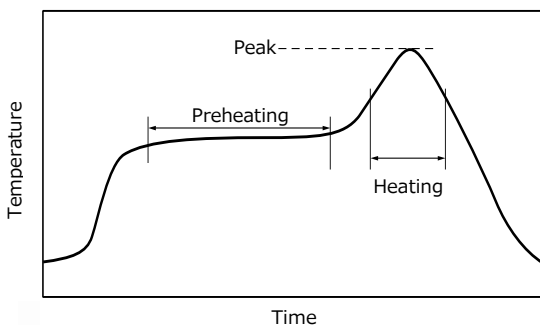

For soldering (Example : Sn/Pb)

| | Temperature | Time |
|--------------|------------------|---------------|
| Preheating | 140 °C to 160 °C | 60 s to 120 s |
| Main heating | Above 200 °C | 30 s to 40 s |
| Peak | 235 ± 5 °C | max. 10 s |

For lead-free soldering (Example : Sn/Ag/Cu)

| | Temperature | Time |
|--------------|------------------|---------------|
| Preheating | 150 °C to 180 °C | 60 s to 120 s |
| Main heating | Above 230 °C | 30 s to 40 s |
| Peak | max. 260 °C | max. 10 s |

Safety Precautions (Common precautions for ESD Suppressor)

- When using our products, no matter what sort of equipment they might be used for, be sure to make a written agreement on the specifications with us in advance. The design and specifications in this catalog are subject to change without prior notice.
- Do not use the products beyond the specifications described in this catalog.
- This catalog explains the quality and performance of the products as individual components. Before use, check and evaluate their operations when installed in your products under the actual conditions for use.
- Install the following systems for a failsafe design to ensure safety if these products are to be used in equipment where a defect in these products may cause the loss of human life or other significant damage, such as damage to vehicles (automobile, train, vessel), traffic lights, medical equipment, aerospace equipment, electric heating appliances, combustion/gas equipment, rotating equipment, and disaster/crime prevention equipment.
- * Systems equipped with a protection circuit and a protection device.
- * Systems equipped with a redundant circuit or other system to prevent an unsafe status in the event of a single fault.
- * Systems equipped with an arresting the spread of fire or preventing glitch.

(1) Precautions for use

- These products are designed and manufactured for general and standard use in general electronic equipment. (e.g. AV equipment, home electric appliances, office equipment, information and communication equipment) For applications in which special quality and reliability are required, or if the failure or malfunction of the products may directly jeopardize life or cause threat of personal injury (such as for aircraft and aerospace equipment, traffic and transport equipment, combustion equipment, medical equipment, accident prevention and anti-theft devices, and safety equipment), please be sure to consult with our sales representative in advance and to exchange product specifications which conform to such applications.
- These products are not intended for use in the following special conditions. Before using the products, carefully check the effects on their quality and performance, and determine whether or not they can be used.
 1. In liquid, such as water, oil, chemicals, or organic solvent.
 2. In direct sunlight, outdoors, or in dust.
 3. In salty air or air with a high concentration of corrosive gas, such as Cl_2 , H_2S , NH_3 , SO_2 , or NO_x .
 4. Electromagnetic and Radioactive Environment.
Avoid any environment where strong electromagnetic waves and radiation exist.
 5. In an environment where these products cause dew condensation.
 6. Sealing or coating of these products or a printed circuit board on which these products are mounted, with resin or other materials.
- These products generate Joule heat when energized. Carefully position these products so that their heat will not affect the other components.
- Carefully position these products so that their temperatures will not exceed the category temperature range due to the effects of neighboring heat-generating components. Do not mount or place heat-generating components or inflammables, such as vinyl-coated wires, near these products.
- Note that non-cleaning solder, halogen-based highly active flux, or water-soluble flux may deteriorate the performance or reliability of the products.
- Carefully select a flux cleaning agent for use after soldering. An unsuitable agent may deteriorate the performance or reliability. In particular, when using water or a water-soluble cleaning agent, be careful not to leave water residues. Otherwise, the insulation performance may be deteriorated.
- Do not apply flux to these products after soldering. The activity of flux may be a cause of failures in these products.
- Refer to the recommended soldering conditions and set the soldering condition. High peak temperature or long heating time may impair the performance or the reliability of these products.
- Recommended soldering condition is for the guideline for ensuring the basic characteristics of the products, not for the stable soldering conditions. Conditions for proper soldering should be set up according to individual conditions.
- Do not reuse any products after removal from mounting boards.
- Do not drop these products. If these products are dropped, do not use them. Such products may have received mechanical or electrical damage.

- If any doubt or concern to the safety on these products arise, make sure to inform us immediately and conduct technical examinations at your side.

(2) Precautions for storage

The performance of these products, including the solderability, is guaranteed for a year from the date of arrival at your company, provided that they remain packed as they were when delivered and stored at a temperature of 5 °C to 35 °C and a relative humidity of 45 % to 85 %.

Even within the above guarantee periods, do not store these products in the following conditions. Otherwise, their electrical performance and/or solderability may be deteriorated, and the packaging materials (e.g. taping materials) may be deformed or deteriorated, resulting in mounting failures.

1. In salty air or in air with a high concentration of corrosive gas, such as Cl₂, H₂S, NH₃, SO₂, or NO_x.
2. In direct sunlight.

(3) Precaution specific to this product

1. If a large electric surge (especially, one which is larger than an ESD) is expected to be applied, be sure to test and confirm proper ESD Suppressor (hereafter called the suppressors) functionality when mounted on your board. When the applied load is more than the allowable rated power under normal load conditions, it may impair performance and/or the reliability of the suppressors. Never exceed the rated power. If the product will be used under these special conditions, be sure to contact a Panasonic representative first.
2. Do not use halogen-based or other high-activity flux. Otherwise, the residue may impair the suppressors' performance and/or reliability.
3. When soldering with a soldering iron, never touch the suppressors' bodies with the tip of the soldering iron. When using a soldering iron with a high temperature tip, finish soldering as quickly as possible (within three seconds at 350 °C max.).
4. Mounting of the suppressors with excessive or insufficient wetting amount of solder may affect the connection reliability or the performance of the suppressors. Carefully check the effects and apply a proper amount of solder for use.
5. When the suppressors' protective coatings are chipped, flawed, or removed, the characteristics of the suppressors may be impaired. Take special care not to apply mechanical shock during automatic mounting or cause damage during handling of the boards with the suppressors mounted.
6. Do not apply shock to the suppressors or pinch them with a hard tool (e.g. pliers and tweezers). Otherwise, the suppressors' protective coatings and bodies may be chipped, affecting their performance.
7. Avoid excessive bending of printed circuit boards in order to protect the suppressors from abnormal stress.
8. Do not immerse the suppressors in solvent for a long time. Before using solvent, carefully check the effects of immersion.
9. Do not apply excessive tension to the terminals.

(4) AEC-Q200 Compliant (ESD Suppressor, High Withstanding Type)

The products are tested based on all or part of the test conditions and methods defined in AEC-Q200.

Please consult with Panasonic for the details of the product specification and specific evaluation test results, etc., and please review and approve Panasonic's product specification before ordering.

<Package markings>

Package markings include the product number, quantity, and country of origin.

In principle, the country of origin should be indicated in English.



Multilayer Varistor (Automotive Grade)

Series: **EZJZ-M, EZJP-M**

Features

- Excellent ESD suppression due to original advanced material technology
- Having large electrostatic resistance meeting IEC61000-4-2, ISO10605
- Having no polarity (bipolar) facilitated replacing Zener Diodes. Capable of replacing 2 Zener Diodes and 1 Capacitor
- Lead-free plating terminal electrodes enabling great solderability
- Wide range of products is available by adopting multilayer structure, meeting various needs
- AEC-Q200 compliant
- RoHS compliant

■ As for Packaging Methods, Handling Precautions Please see Data Files

Explanation of Part Numbers

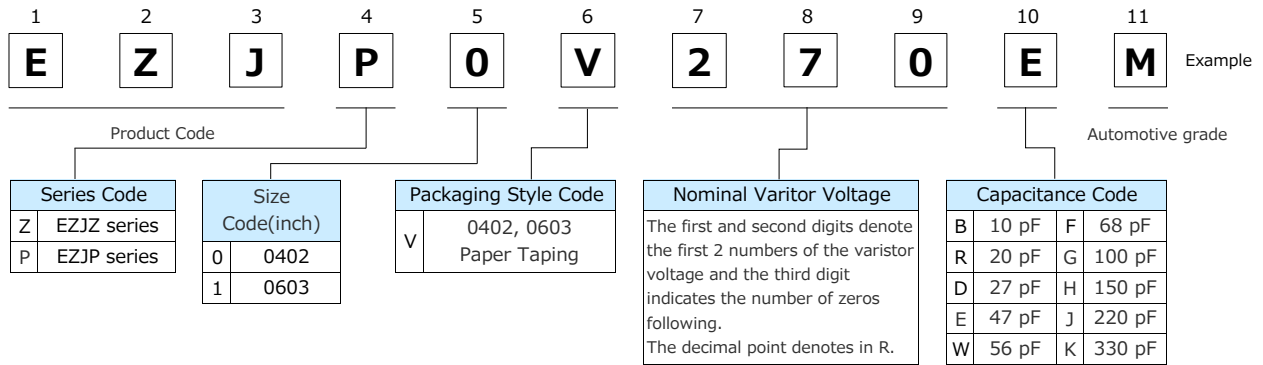

Construction

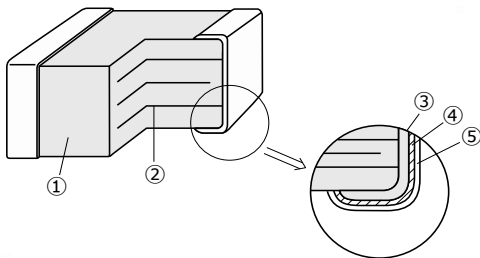

| No. | Name | |
|-----|---------------------------|------------------------|
| ① | Zinc oxide-based ceramics | |
| ② | Internal electrode | |
| ③ | Terminal electrode | Substrate electrode |
| ④ | | Intermediate electrode |
| ⑤ | | External electrode |

Dimensions in mm (not to scale)

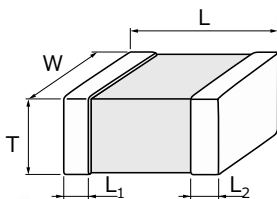

| Size Code | Size(inch) | L | W | T | L ₁ , L ₂ |
|-----------|------------|-----------|-----------|-----------|---------------------------------|
| 0 | 0402 | 1.00±0.05 | 0.50±0.05 | 0.50±0.05 | 0.2±0.1 |
| 1 | 0603 | 1.6±0.1 | 0.8±0.1 | 0.8±0.1 | 0.3±0.2 |

Features

Wide variety of products is available by adopting multilayer construction, which achieved wide range of usage, such as application to DC voltage lines and signal lines.

- Varistor voltage : 12 to 100 V (at 1 mA)
- Capacitance : 10 to 220 pF max. (at 1 MHz)
- Circuit voltage

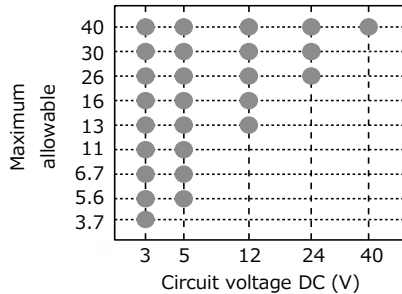

Recommended Applications

- Engine ECU
- Various body ECU
- Communication line, such as CAN, LIN
- Audio, Navigation
- LED Light
- Control SW

Ratings and Characteristics

| Size (inch) | Part No. | Maximum allowable voltage DC (V) | Nominal varistor voltage at 1 mA (V) | Capacitance (pF) | | Maximum peak current at 8/20 μs, 2 times (A) | Maximum ESD | |
|-------------|------------------------|----------------------------------|--------------------------------------|--------------------|-----------|--|----------------------------|-------------------------|
| | | | | at 1 MHz | at 1 kHz | | IEC61000-4-2 150 pF/ 330 Ω | ISO10605 330 pF/ 2 kΩ |
| 0402 | NEW EZJP0V120JM | 7.5 | 12 | 220 max.[150 typ.] | 175 typ. | 10 | Contact discharge 8 kV | Contact discharge 25 kV |
| | EZJP0V180HM | 11 | 18 | 150 max.[120 typ.] | 140 typ. | 10 | | |
| | EZJP0V220HM | 13 | 22 | 150 max.[100 typ.] | 116 typ. | 10 | | |
| | EZJP0V270GM | 18 | 27 | 100 max.[85 typ.] | 100 typ. | 10 | | |
| | EZJP0V270EM | 18 | 27 | 47 max.[33 typ.] | 37 typ. | 4 | | |
| | EZJP0V270RM | 18 | 27 | 20 max.[15 typ.] | 16.5 typ. | 2 | | |
| | EZJP0V270BM | 18 | 27 | 10 max.[8 typ.] | 10 typ. | — | | |
| | EZJP0V330GM | 25 | 33 | 100 max.[85 typ.] | 100 typ. | 10 | | |
| | EZJP0V420WM | 30 | 42 | 56 max.[40 typ.] | 45 typ. | 6 | | |
| | EZJP0V650DM | 40 | 65 | 27 max.[22 typ.] | 33 typ. | 2 | | |
| EZJP0V101BM | 30 | 100 | 10 max.[8 typ.] | 10 typ. | — | | | |
| 0603 | NEW EZJP1V120KM | 7.5 | 12 | 330 max.[250 typ.] | 290 typ. | 20 | | |
| | EZJP1V180JM | 11 | 18 | 220 max.[180 typ.] | 210 typ. | 20 | | |
| | EZJP1V220JM | 13 | 22 | 220 max.[160 typ.] | 185 typ. | 10 | | |
| | EZJP1V270GM | 18 | 27 | 100 max.[85 typ.] | 100 typ. | 10 | | |
| | EZJP1V270EM | 18 | 27 | 47 max.[33 typ.] | 37 typ. | 5 | | |
| | EZJP1V270RM | 18 | 27 | 20 max.[15 typ.] | 16.5 typ. | 2 | | |
| | EZJP1V330GM | 25 | 33 | 100 max.[85 typ.] | 100 typ. | 10 | | |
| | EZJP1V420FM | 30 | 42 | 68 max.[55 typ.] | 63 typ. | 8 | | |
| | EZJP1V650DM | 40 | 65 | 27 max.[22 typ.] | 33 typ. | 2 | | |
| | EZJZ1V180JM | 11 | 18 | 220 max.[180 typ.] | 210 typ. | 20 | | |
| | EZJZ1V220JM | 13 | 22 | 220 max.[160 typ.] | 185 typ. | 20 | | |
| | EZJZ1V270GM | 16 | 27 | 100 max.[85 typ.] | 100 typ. | 20 | | |
| | EZJZ1V330GM | 26 | 33 | 100 max.[85 typ.] | 100 typ. | 20 | | |
| | EZJZ1V420FM | 30 | 42 | 68 max.[55 typ.] | 63 typ. | 15 | | |
| | EZJZ1V650DM | 40 | 65 | 27 max.[22 typ.] | 33 typ. | 5 | | |

- Operating Temperature Range : EZJP serie -55 to 150 °C, EZJZ serie -55 to 125 °C

* Recommend soldering method : Reflow soldering

| | |
|---------------------------|--|
| Maximum Allowable Voltage | Maximum DC Voltage that can be applied continuously within the operating temperature range |
| Varistor Voltage | Varistor starting voltage between terminals at DC 1 mA, also known as Breakdown voltage |
| Maximum Peak Current | Maximum current that can be withstood under the standard pulse 8/20 μs, 2 times based |
| Maximum ESD | Maximum voltage that can be withstood under ESD |

Varistor Characteristics and Equivalent Circuit

A Multilayer Varistor does not have an electrical polarity like zener diodes and is equivalent to total 3 pcs of 2 zener diodes and 1 capacitor.

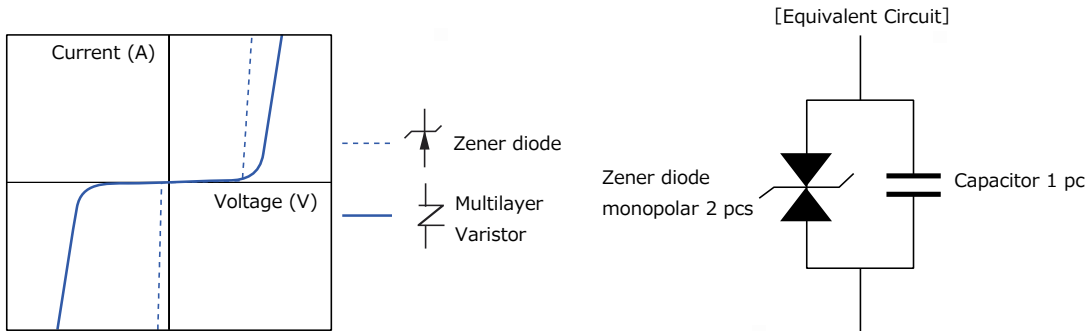

ESD Suppressive Effects

Typical effects of ESD suppression

Test conditions :

IEC61000-4-2* Level4 Contact discharge, 8 kV

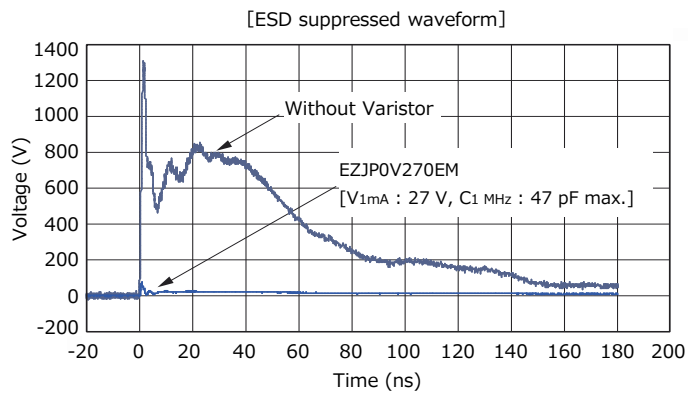
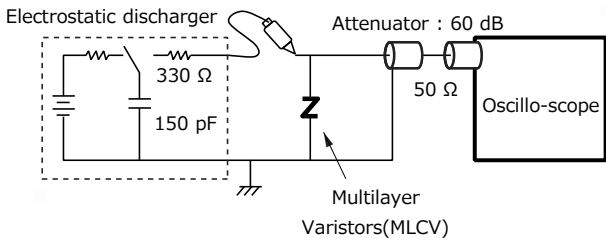

*IEC61000-4-2 ... International Standard of the ESD testing method (HBM) for electronic equipment ability to withstand ESD generated from a human body. It sets 4 levels of severity

| Severity | Level 1 | Level 2 | Level 3 | Level 4 |
|-------------------|---------|---------|---------|---------|
| Contact discharge | 2 kV | 4 kV | 6 kV | 8 kV |
| Air discharge | 2 kV | 4 kV | 8 kV | 15 kV |

Replacement of Zener diode

Replacing "Zener diode and Capacitor" with Multilayer Varistor saves both the mounting area and number of components used.

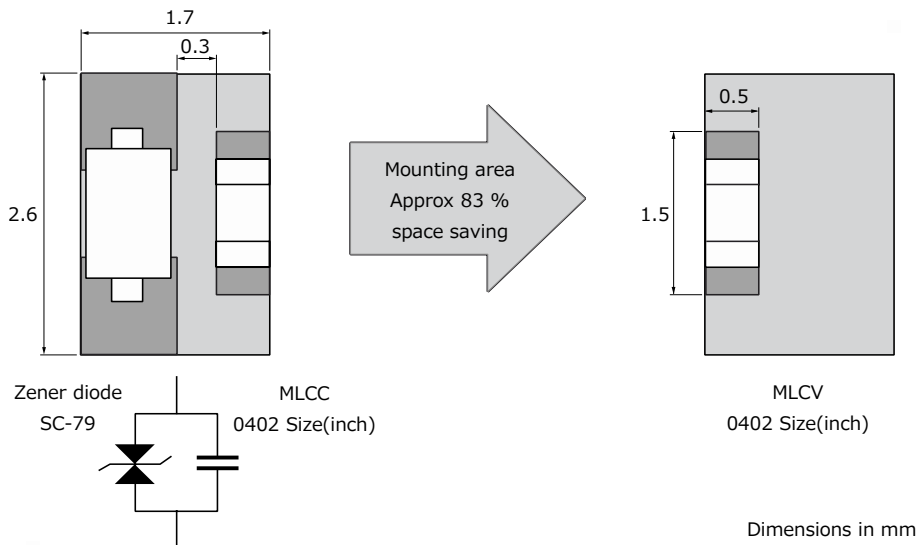

Performance and Testing Methods

| Characteristics | Specifications | Testing Method | | | | | | | | | | | | | | | |
|--------------------------------------|--------------------------------------|---|------|-------------|--------|---|----------------------|----------------|---|----------------|------------|---|----------------------|----------------|---|----------------|------------|
| Standard test conditions | | Electrical characteristics shall be measured under the following conditions. Temp. : 5 to 35 °C, Relative humidity : 85 % or less | | | | | | | | | | | | | | | |
| Varistor voltage | To meet the specified value. | The Varistor voltage is the voltage (V_C or V_{CMA}) between both end terminals of a Varistor when specified current (CmA) is applied to it. The measurement shall be made as quickly as possible to avoid heating effects. | | | | | | | | | | | | | | | |
| Maximum allowable voltage | To meet the specified value. | The maximum DC voltage that can be applied continuously to a varistor. | | | | | | | | | | | | | | | |
| Capacitance | To meet the specified value. | Capacitance shall be measured at the specified frequency, bias voltage 0 V, and measuring voltage 0.2 to 2.0 V_{rms} | | | | | | | | | | | | | | | |
| Maximum peak current | To meet the specified value. | The maximum current measured (Varistor voltage tolerance is within $\pm 10\%$) when a standard impulse current of 8/20 μ seconds is applied twice with an interval of 5 minutes. | | | | | | | | | | | | | | | |
| Maximum ESD | To meet the specified value. | The maximum ESD measured (while the varistor voltage is within blow ranges of its nominal value) when exposed to ESD 10 times (five times for each positive-negative polarity) based on IEC61000-4-2, ISO10605. EZJP□□□□□□M : within $\pm 10\%$, EZJZ□□□□□□M : within $\pm 30\%$ | | | | | | | | | | | | | | | |
| Solder ability | To meet the specified value. | The part shall be immersed into a soldering bath under the conditions below. Solder : Sn-Ag-Cu Soldering flux : Ethanol solution of rosin (Concentration approx. 25 wt%) Soldering temp. : 230 ± 5 °C Period : 4 ± 1 s Soldering position : Immerse both terminal electrodes until they are completely into the soldering bath. | | | | | | | | | | | | | | | |
| Resistance to soldering heat | $\Delta V_C/V_C$: within $\pm 10\%$ | After the immersion, leave the part for 24 ± 2 hours under the standard condition, then evaluate its characteristics. Soldering conditions are specified below: Soldering conditions : 270 °C , 3 s / 260 °C , 10 s Soldering position : Immerse both terminal electrodes until they are completely into the soldering bath. | | | | | | | | | | | | | | | |
| Temperature cycling | $\Delta V_C/V_C$: within $\pm 10\%$ | After repeating the cycles stated below for specified number of times, leave the part for 24 ± 2 hours, then evaluate its characteristics. Cycle : 2000 cycles <table border="1" style="margin-left: auto; margin-right: auto;"> <thead> <tr> <th>Step</th> <th>Temperature</th> <th>Period</th> </tr> </thead> <tbody> <tr> <td>1</td> <td>Max. Operating Temp.</td> <td>30 ± 3 min</td> </tr> <tr> <td>2</td> <td>Ordinary temp.</td> <td>3 min max.</td> </tr> <tr> <td>3</td> <td>Min. Operating Temp.</td> <td>30 ± 3 min</td> </tr> <tr> <td>4</td> <td>Ordinary temp.</td> <td>3 min max.</td> </tr> </tbody> </table> | Step | Temperature | Period | 1 | Max. Operating Temp. | 30 ± 3 min | 2 | Ordinary temp. | 3 min max. | 3 | Min. Operating Temp. | 30 ± 3 min | 4 | Ordinary temp. | 3 min max. |
| Step | Temperature | Period | | | | | | | | | | | | | | | |
| 1 | Max. Operating Temp. | 30 ± 3 min | | | | | | | | | | | | | | | |
| 2 | Ordinary temp. | 3 min max. | | | | | | | | | | | | | | | |
| 3 | Min. Operating Temp. | 30 ± 3 min | | | | | | | | | | | | | | | |
| 4 | Ordinary temp. | 3 min max. | | | | | | | | | | | | | | | |
| Vibration | $\Delta V_C/V_C$: within $\pm 10\%$ | The varistor shall be soldered on the testing board shown. G force : 5 G Vibration frequency range : 10 to 2000 Hz Sweet time : 20 min. Sweet direction : 12 cycles for 3 courses perpendicular each other | | | | | | | | | | | | | | | |
| Mechanical Shock | $\Delta V_C/V_C$: within $\pm 10\%$ | The varistor shall be soldered on the testing board shown. Shock-wave formation : Half sine , 11 ms G force : 50 G Sweet direction : 6 directions of X, Y, Z, for each three times | | | | | | | | | | | | | | | |
| Biased Humidity | $\Delta V_C/V_C$: within $\pm 10\%$ | After conducting the test under the conditions specified below, leave the part 24 ± 2 hours, then evaluate its characteristics. Temp. : 85 ± 2 °C Humidity : 80 to 85 %RH Applied voltage : Maximum allowable voltage (Individually specified) Period : 2000+24/0 h | | | | | | | | | | | | | | | |
| High temperature exposure (dry heat) | $\Delta V_C/V_C$: within $\pm 10\%$ | After conducting the test under the conditions specified below, leave the part 24 ± 2 hours, then evaluate its characteristics. Temp. : Maximum operating temperature ± 3 °C (Individually specified) Applied voltage : Maximum allowable voltage (Individually specified) Period : 2000+24/0 h | | | | | | | | | | | | | | | |

Packaging Methods (Taping)

● Standard Quantity

| Series | Size Code (inch size) | Thickness (mm) | Kind of Taping | Pitch (mm) | Quantity (pcs/reel) |
|------------|-----------------------|----------------|------------------------|------------|---------------------|
| EZJZ, EZJP | 0 (0402) | 0.5 | Punched Carrier Taping | 2 | 10,000 |
| | 1(0603) | 0.8 | | 4 | 4,000 |

● 2 mm Pitch (Punched Carrier Taping) Size 0402

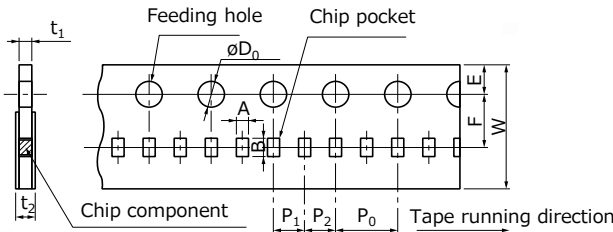

| Symbol | A | B | W | F | E | P ₁ | P ₂ | P ₀ | øD ₀ | t ₁ | t ₂ |
|-----------|------------|------------|----------|------------|------------|----------------|----------------|----------------|-----------------|----------------|----------------|
| Unit (mm) | 0.62 ±0.05 | 1.12 ±0.05 | 8.0 ±0.2 | 3.50 ±0.05 | 1.75 ±0.10 | 2.00 ±0.05 | 2.00 ±0.05 | 4.0 ±0.1 | 1.5 ±0.1 0 | 0.7 max. | 1.0 max. |

● 4 mm Pitch (Punched Carrier Taping) Size 0603

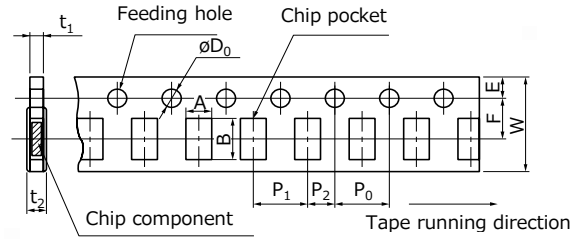

| Symbol | A | B | W | F | E | P ₁ | P ₂ | P ₀ | øD ₀ | t ₁ | t ₂ |
|-----------|----------|----------|----------|------------|------------|----------------|----------------|----------------|-----------------|----------------|----------------|
| Unit (mm) | 1.0 ±0.1 | 1.8 ±0.1 | 8.0 ±0.2 | 3.50 ±0.05 | 1.75 ±0.10 | 4.0 ±0.1 | 2.00 ±0.05 | 4.0 ±0.1 | 1.5 ±0.1 0 | 1.1 max. | 1.4 max. |

● Reel for Taping

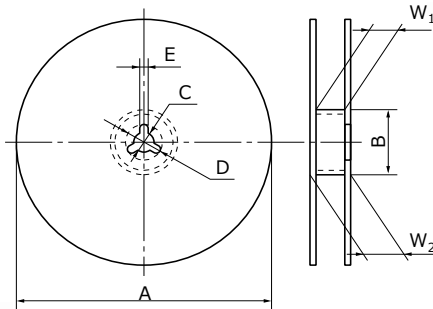

| Symbol | A | B | C | D | E | W ₁ | W ₂ |
|-----------|---------------------------------|------------------------------------|----------|----------|---------|----------------------------------|----------------|
| Unit (mm) | ø180 ⁰ ₋₃ | ø60.0 ^{+1.0} ₀ | 13.0±0.5 | 21.0±0.8 | 2.0±0.5 | 9.0 ^{+1.0} ₀ | 11.4±1.0 |

● Leader Part and Taped End

Leader part

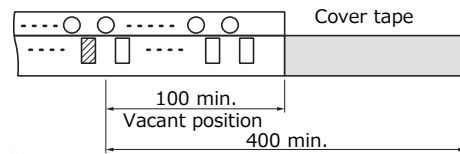

Tape end

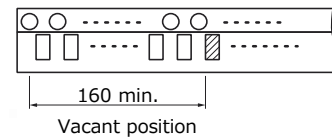

Unit (mm)

Multilayer Varistors,Chip Type (Automotive Grade)

Series: EZJZ-M, EZJP-M

Handling Precautions

[Precautions]

- **Do not use the products beyond the descriptions in this product catalog.**
- **This product catalog guarantees the quality of the products as individual components. Before you use the products, please make sure to check and evaluate the products in the circumstance where they are installed in your product.**

! Safety Precautions

Multilayer Varistors(Automotive Grade) (hereafter referred to as "Varistors") should be used for general purpose applications as countermeasures against ESD and noise found in vehicle electronics (Engine ECU and various body ECU, accessory equipment, etc.) equipment. When subjected to severe electrical, environmental, and/or mechanical stress beyond the specifications, as noted in the Ratings and Specified Conditions section, the Varistors' performance may be degraded, or become failure mode, such as short circuit mode and open-circuit mode. If you use under the condition of short-circuit, heat generation of Varistors will occur by running large current due to application of voltage. There are possibilities of smoke emission, substrate burn-out, and, in the worst case, fire. For products which require high safety levels, please carefully consider how a single malfunction can affect your product. In order to ensure the safety in the case of a single malfunction, please design products with fail-safe, such as setting up protecting circuits, etc.

We are trying to improve the quality and the reliability, but the durability differs depending on the use environment and the use conditions. On use, be sure to confirm the actual product under the actual use conditions.

- For the following applications and conditions, please be sure to consult with our sales representative in advance and to exchange product specifications which conform to such applications.
 - When your application may have difficulty complying with the safety or handling precautions specified below.
 - High-quality and high-reliability required devices that have possibility of causing hazardous conditions, such as death or injury (regardless of directly or indirectly), due to failure or malfunction of the product.
 - ① Aircraft and Aerospace Equipment (artificial satellite, rocket, etc.)
 - ② Submarine Equipment (submarine repeating equipment, etc.)
 - ③ Transportation Equipment (airplanes, trains, ship, traffic signal controllers, etc.)
 - ④ Power Generation Control Equipment
(atomic power, hydroelectric power, thermal power plant control system, etc.)
 - ⑤ Medical Equipment (life-support equipment, pacemakers, dialysis controllers, etc.)
 - ⑥ Information Processing Equipment (large scale computer systems, etc.)
 - ⑦ Electric Heating Appliances, Combustion devices (gas fan heaters, oil fan heaters, etc.)
 - ⑧ Rotary Motion Equipment
 - ⑨ Security Systems
 - ⑩ And any similar types of equipment

! Strict Observance**1. Confirmation of Rated Performance**

The Varistors shall be operated within the specified rating/performance.

Applications exceeding the specifications may cause deteriorated performance and/or breakdown, resulting in degradation and/or smoking or ignition of products. The following are strictly observed.

- (1) The Varistors shall not be operated beyond the specified operating temperature range.
- (2) The Varistors shall not be operated in excess of the specified maximum allowable voltage.
- (3) The Varistors shall not be operated in the circuits to which surge current and ESD that exceeds the specified maximum peak current and maximum ESD.
- (4) Never use for AC power supply circuits.

2. The Varistors shall not be mounted near flammables.

Operating Conditions and Circuit Design

1. Circuit Design

1.1 Operating Temperature and Storage Temperature

When operating a components-mounted circuit, please be sure to observe the "Operating Temperature Range", written in delivery specifications. Storage temperature of PCB after mounting Varistors, which is not operated, should be within the specified "Storage Temperature Range" in the delivery specifications. Please remember not to use the product under the condition that exceeds the specified maximum temperature.

1.2 Operating Voltage

The Varistors shall not be operated in excess of the "Maximum allowable voltage". If the Varistors are operated beyond the specified Maximum allowable voltage, it may cause short and/or damage due to thermal run away. The circuit that continuously applies high frequency and/or steep pulse voltage please examines the reliability of the Varistor even if it is used within a "Maximum allowable voltage". Also, it would be safer to check also the safety and reliability of your circuit.

1.3 Self-heating

The surface temperature of the Varistors shall be under the specified Maximum Operating Temperature in the Specifications including the temperature rise caused by self-heating. Check the temperature rise of the Varistor in your circuit.

1.4 Environmental Restrictions

The Varistors does not take the use under the following special environments into consideration. Accordingly, the use in the following special environments, and such environmental conditions may affect the performance of the product; prior to use, verify the performance, reliability, etc. thoroughly.

- ① Use in liquids such as water, oil, chemical, and organic solvent.
- ② Use under direct sunlight, in outdoor or in dusty atmospheres.
- ③ Use in places full of corrosive gases such as sea breeze, Cl₂, H₂S, NH₃, SO₂, and NOx.
- ④ Use in environment with large static electricity or strong electromagnetic waves or strong radial ray.
- ⑤ Where the product is close to a heating component, or where an inflammable such as a polyvinyl chloride wire is arranged close to the product.
- ⑥ Where this product is sealed or coated with resin etc.
- ⑦ Where solvent, water, or water-soluble detergent is used in flux cleaning after soldering.
(Pay particular attention to water-soluble flux.)
- ⑧ Use in such a place where the product is wetted due to dew condensation.
- ⑨ Use the product in a contaminated state.
Ex.) Do not handle the product such as sticking sebum directly by touching the product after mounting printed circuit board.
- ⑩ Under severe conditions of vibration or impact beyond the specified conditions found in the Specifications.

2. Design of Printed Circuit Board

2.1 Selection of Printed Circuit Boards

There is a possibility of performance deterioration by heat shock (temperature cycles), which causes cracks, from alumina substrate. Please confirm that the substrate you use does not deteriorate the Varistors' quality.

2.2 Design of Land Pattern

- 1) Recommended land dimensions are shown below. Use the proper amount of solder in order to prevent cracking. Using too much solder places excessive stress on the Varistors.

Recommended Land Dimensions(Ex.)

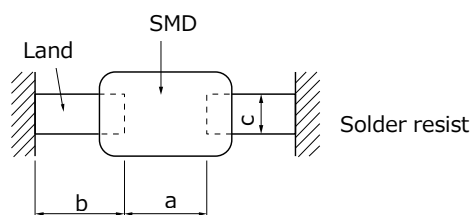

| Size Code/EIA | Component dimensions | | | Unit (mm) | | |
|------------------|----------------------|-----|-----|------------|------------|------------|
| | L | W | T | a | b | c |
| 0(0402) | 1.0 | 0.5 | 0.5 | 0.4 to 0.5 | 0.4 to 0.5 | 0.4 to 0.5 |
| 1(0603) | 1.6 | 0.8 | 0.8 | 0.8 to 1.0 | 0.6 to 0.8 | 0.6 to 0.8 |

(2) The land size shall be designed to have equal space, on both right and left side. If the amount of solder on the right land is different from that of the left land, the component may be cracked by stress since the side with a larger amount of solder solidifies later during cooling.

Recommended Amount of Solder

(a) Excessive amount (b) Proper amount (c) Insufficient amount

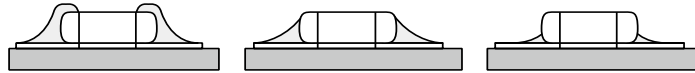

2.3 Utilization of Solder Resist

(1) Solder resist shall be utilized to equalize the amounts of solder on both sides.

(2) Solder resist shall be used to divide the pattern for the following cases;

- Components are arranged closely.
- The Varistor is mounted near a component with lead wires.
- The Varistor is placed near a chassis.

See the table right.

Prohibited Applications and Recommended Applications

| Item | Prohibited applications | Improved applications by pattern division |
|---|--|---|
| Mixed mounting with a component with lead wires | The lead wire of a Component With lead wires | Solder resist |
| Arrangement near chassis | Chassis Solder(ground solder) Electrode pattern | Solder resist |
| Retro-fitting of component with lead wires | A lead wire of Retrofitted component Soldering iron | Solder resist |
| Lateral arrangement | Portion to be Excessively soldered Land | Solder resist |

2.4 Component Layout

To prevent the crack of Varistors, place it on the position that could not easily be affected by the bending stress of substrate while going through procedures after mounting or handling.

(1) To minimize mechanical stress caused by the warp or bending of a PC board, please follow the recommended Varistors' layout below.

| Prohibited layout | Recommended layout |
|-------------------|--|
| | Layout the Varistors sideways against the stressing direction. |

- (2) The following layout is for your reference since mechanical stress near the dividing/breaking position of a PC board varies depending on the mounting position of the Varistors.

Magnitude of stress
 $A > B = C > D > E$

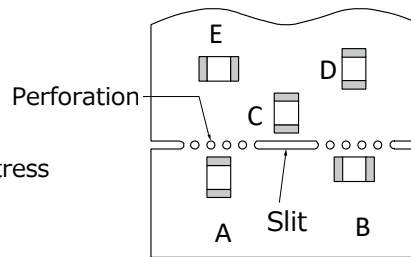

- (3) The magnitude of mechanical stress applied to the Varistors when dividing the circuit board in descending order is as follows: push back < slit < V-groove < perforation. Also take into account the layout of the Varistors and the dividing/breaking method.

2.5 Mounting Density and Spaces

Intervals between components should not be too narrow to prevent the influence from solder bridges and solder balls. The space between components should be carefully determined.

Precautions for Assembly

1. Storage

- (1) The Varistors shall be stored between 5 to 40 °C and 20 to 70 % RH, not under severe conditions of high temperature and humidity.
- (2) If stored in a place where humidity, dust, or corrosive gasses (hydrogen sulfide, sulfurous acid, hydrogen chloride and ammonia, etc.) are contained, the solderability of terminal electrodes will be deteriorated. In addition, storage in a place where the heat or direct sunlight exposure occurs will causes or direct sunlight exposure occurs will causes mounting problems due to deformation of tapes and reels and components and taping/reels sticking together.
- (3) Do not store components longer than 6 months. Check the solderability of products that have been stored for more than 6 months before use.

2. Adhesives for Mounting

- (1) The amount and viscosity of an adhesive for mounting shall be such that the adhesive will not flow off on the land during its curing.
- (2) If the amount of adhesive is insufficient for mounting, the Varistors may fall off after or during soldering.
- (3) Low-viscosity of the adhesive causes displacement of Varistors.
- (4) The heat-curing methods for adhesive are ultraviolet radiation, far-infrared radiation, and so on. In order to prevent the terminal electrodes of the Varistors from oxidizing, the curing shall be under the following conditions: 160 °C max., for 2 minutes max.
- (5) Insufficient curing may cause the Varistors to fall off after or during soldering. In addition, insulation resistance between terminal electrodes may deteriorate due to moisture absorption. In order to prevent these problems, please observe proper curing conditions.

3. Chip Mounting Consideration

- (1) When mounting the Varistors components on a PC board, the Varistor bodies shall be free from excessive impact loads such as mechanical impact or stress due to the positioning, pushing force and displacement of vacuum nozzles during mounting.
- (2) Maintenance and inspection of the Chip Mounter must be performed regularly.
- (3) If the bottom dead center of the vacuum nozzle is too low, the Varistor will crack from excessive force during mounting. Please refer to the following precautions and recommendations.
 - (a) Set and adjust the bottom dead center of the vacuum nozzles to the upper surface of the PC board after correcting the warp of the PC board.
 - (b) Set the pushing force of the vacuum nozzle during mounting to 1 to 3 N in static load.
 - (c) For double surface mounting, apply a supporting pin on the rear surface of the PC board to suppress the bending of the PC board in order to minimize the impact of the vacuum nozzles. Typical examples are shown in the table below secondary.
 - (d) Adjust the vacuum nozzles so that their bottom dead center during mounting is not too low.

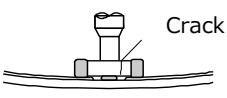
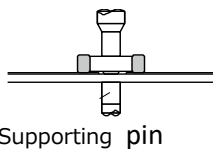
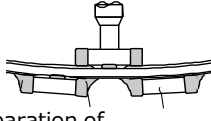
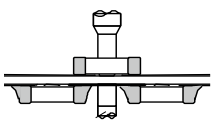
| Item | Prohibited mounting | Recommended mounting |
|-------------------------|--|---|
| Single surface mounting |  Crack |  Supporting pin The supporting pin does not necessarily have to be positioned |
| Double surface mounting |  Separation of Crack |  Supporting pin |

- (4) The closing dimensions of the positioning chucks shall be controlled. Maintenance and replacement of positioning chucks shall be performed regularly to prevent chipping or cracking of the Varistors caused by mechanical impact during positioning due to worn positioning chucks.
- (5) Maximum stroke of the nozzle shall be adjusted so that the maximum bending of PC board does not exceed 0.5 mm at 90 mm span. The PC board shall be supported by an adequate number of supporting pins.

4. Selection of Soldering Flux

Soldering flux may seriously affect the performance of the Varistors. Please confirm enough whether the soldering flux have an influence on performance of the Varistors or not, before using.

5. Soldering

5.1 Flow Soldering

When conducting flow soldering, stress from abrupt temperature change is applied to the Varistors, so the temperature, especially temperature of solder should be controlled very carefully. Varistors should not be subjected to abrupt temperature change because it causes occurrence of thermal cracks as a result of excessive thermal stress inside of the Varistors from flow soldering. You should be careful to temperature difference. Therefore it is essential that soldering process follow these recommended conditions.

- (1) Application of Soldering flux :
The soldering flux shall be applied to the mounted Varistors thinly and uniformly by foaming method.
- (2) Preheating : Conduct sufficient pre-heating, and make sure that the temperature difference between solder and Varistors' surface is 150 °C or less.
- (3) Immersion into Soldering bath :
The Varistors shall be immersed into a soldering bath of 240 to 260 °C for 3 to 5 seconds.
- (4) Gradual Cooling : After soldering, avoid rapid cooling (forced cooling) and conduct gradual cooling, so that thermal cracks do not occur.
- (5) Flux Cleaning : When the Varistors are immersed into a cleaning solvent, be sure that the surface temperatures of devices do not exceed 100 °C.
- (6) Performing flow soldering once under the conditions shown in the figure below
[Recommended profile of Flow soldering (Ex.)] will not cause any problems.
However, pay attention to the possible warp and bending of the PC board.

Recommended profile of Flow Soldering (Ex.)

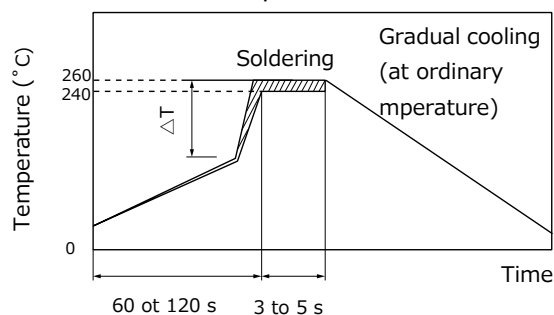

| Size/EIA | Temp. Tol. |
|----------|------------|
| 0603 | T ≤ 150 °C |

<ΔT: Allowable temperature difference>

For products specified in individual specifications, avoid flow soldering.

5.2 Reflow Soldering

The reflow soldering temperature conditions are composed of temperature curves of Preheating, Temp. rise, Heating, Peak and Gradual cooling. Large temperature difference inside the Varistors caused by rapid heat application to the Varistors may lead to excessive thermal stresses, contributing to the thermal cracks. The Preheating temperature requires controlling with great care so that tombstone phenomenon may be prevented.

Recommended profile of Reflow Soldering (Ex.)

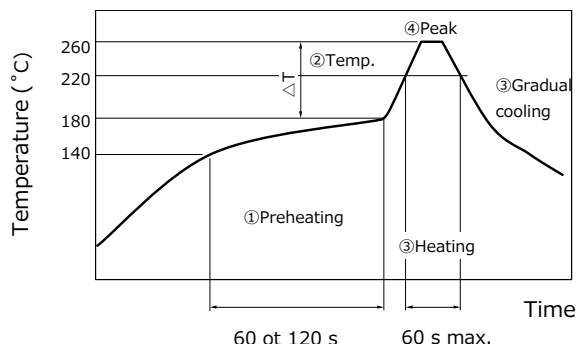

| Item | Temperature | Period or Speed |
|-------------------|-------------------------------|-----------------|
| ① Preheating | 140 to 180 °C | 60 to 120 s |
| ② Temp. rise | Preheating temp to Peak temp. | 2 to 5 °C / s |
| ③ Heating | 220 °C min. | 60 s max. |
| ④ Peak | 260 °C max. | 10 s max. |
| ⑤ Gradual cooling | Peak temp. to 140 °C | 1 to 4 °C / s |

| Size/EIA | Temp. Tol. |
|------------|------------|
| 0402, 0603 | T ≤ 150 °C |

ΔT : Allowable temperature difference $\Delta T \leq 150$ °C

The rapid cooling (forced cooling) during Gradual cooling part should be avoided, because this may cause defects such as the thermal cracks, etc. When the Varistors are immersed into a cleaning solvent, make sure that the surface temperatures of the devices do not exceed 100 °C. Performing reflow soldering twice under the conditions shown in the figure above [Recommended profile of Flow soldering (Ex.)] will not cause any problems.

However, pay attention to the possible warp and bending of the PC board.

Recommended soldering condition is for the guideline for ensuring the basic characteristics of the components, not for the stable soldering conditions. Conditions for proper soldering should be set up according to individual conditions. The temperature of this product at the time of mounting changes depending on mounting conditions, therefore, please confirm that Product surface becomes the specified temperature when mounting it on the end product.

5.3 Hand Soldering

Hand soldering typically causes significant temperature change, which may induce excessive thermal stresses inside the Varistors, resulting in the thermal cracks, etc. In order to prevent any defects, the following should be observed.

- Control the temperature of the soldering tips with special care.
- Avoid the direct contact of soldering tips with the Varistors and/or terminal electrodes.
- Do not reuse dismantled Varistors.

(1) Condition 1 (with preheating)

- Soldering : Use thread solder ($\phi 1.0$ mm or below) which contains flux with low chlorine, developed for precision electronic equipment.
- Preheating : Conduct sufficient preheating, and make sure that the temperature difference between solder and Varistors' surface is 150 °C or less.
- Temperature of Iron tip: 350 °C max.
(The required amount of solder shall be melted in advance on the soldering tip.)
- Gradual cooling : After soldering, the Varistors shall be cooled gradually at room temperature.

Recommended profile of Hand soldering (Ex.)

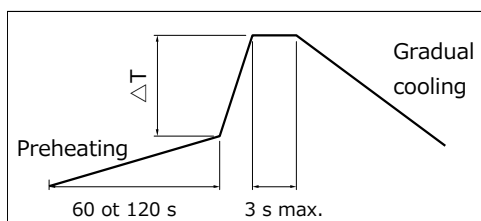

ΔT : Allowable temperature difference $\Delta T \leq 150$ °C

(2) Condition 2 (without preheating)

Hand soldering can be performed without preheating, by following the conditions below:

- (a) Soldering iron tip shall never directly touch the ceramic and terminal electrodes of the Varistors.
- (b) The lands are sufficiently preheated with a soldering iron tip before sliding the soldering iron tip to the terminal electrodes of the Varistors for soldering.

Conditions of Hand soldering without preheating

| Item | Condition |
|--------------------------------------|-------------|
| Temperature of Iron tip | 350 °C max. |
| Wattage | 20 W max. |
| Shape of Iron tip | ∅ 3 mm max. |
| Soldering time with a soldering iron | 3 s max. |

6. Post Soldering Cleaning

6.1 Cleaning solvent

Soldering flux residue may remain on the PC board if cleaned with an inappropriate solvent. This may deteriorate the performance of Varistors, especially insulation resistance.

6.2 Cleaning conditions

Inappropriate cleaning conditions such as insufficient cleaning or excessive cleaning may impair the electrical characteristics and reliability of the Varistors.

(1) Insufficient cleaning can lead to :

- (a) The halogen substance found in the residue of the soldering flux may cause the metal of terminal electrodes to corrode.
- (b) The halogen substance found in the residue of the soldering flux on the surface of the Varistors may change resistance values.
- (c) Water-soluble soldering flux may have more remarkable tendencies of (a) and (b) above compared to those of rosin soldering flux.

(2) Excessive cleaning can lead to :

- (a) When using ultrasonic cleaner, make sure that the output is not too large, so that the substrate will not resonate. The resonance causes the cracks in Varistors and/or solders, and deteriorates the strength of the terminal electrodes. Please follow these conditions for Ultrasonic cleaning:
 - Ultrasonic wave output : 20 W/L max.
 - Ultrasonic wave frequency : 40 kHz max.
 - Ultrasonic wave cleaning time : 5 min. max.

6.3 Contamination of Cleaning solvent

Cleaning with contaminated cleaning solvent may cause the same results as that of insufficient cleaning due to the high density of liberated halogen.

7. Inspection Process

The pressure from measuring terminal pins might bend the PCB when implementing circuit inspection after mounting Varistors on PCB, and as a result, cracking may occur.

- (1) Mounted PC boards shall be supported by an adequate number of supporting pins on the back with bend settings of 90 mm span 0.5 mm max.
- (2) Confirm that the measuring pins have the right tip shape, are equal in height, have the right pressure and are set in the correct positions. The following figures are for your reference to avoid bending the PC board.

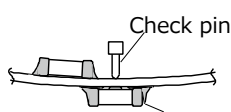
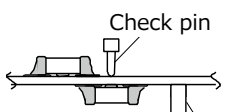
| Item | Prohibited mounting | Recommended mounting |
|---------------------|---|---|
| Bending of PC board |  <p>Separated, Crack</p> |  <p>Supporting pin</p> |

8. Protective Coating

Make sure characteristics and reliability when using the resin coating or resin embedding for the purpose of improvement of humidity resistance or gas resistance, or fixing of parts because failures of a thermistors such as 1) ,2) and 3) may be occurred.

- (1) The solvent which contained in the resin permeate into the Varistors, and it may deteriorate the characteristic.

- (2) When hardening the resin, chemical reaction heat (curing heat generation) happen and it may occurs the infection to the Varistors.
- (3) The lead wire might be cut down and the soldering crack might be happen by expansion or contraction of resin hardening.

9. Dividing/Breaking of PC Boards

- (1) Please be careful not to stress the substrate with bending/twisting when dividing, after mounting components including Varistors. Abnormal and excessive mechanical stress such as bending or torsion shown below can cause cracking in the Varistors.

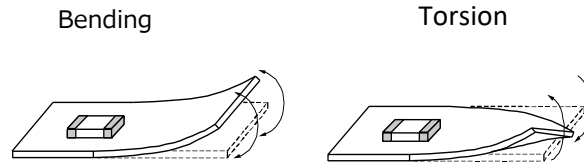

- (2) Dividing/Breaking of the PC boards shall be done carefully at moderate speed by using a jig or apparatus to prevent the Varistors on the boards from mechanical damage.
- (3) Examples of PCB dividing/breaking jigs: The outline of PC board breaking jig is shown below. When PC board are broken or divided, loading points should be close to the jig to minimize the extent of the bending. Also, planes with no parts mounted on should be used as plane of loading, in order to prevent tensile stress induced by the bending, which may cause cracks of the Varistors or other parts mounted on the PC boards.

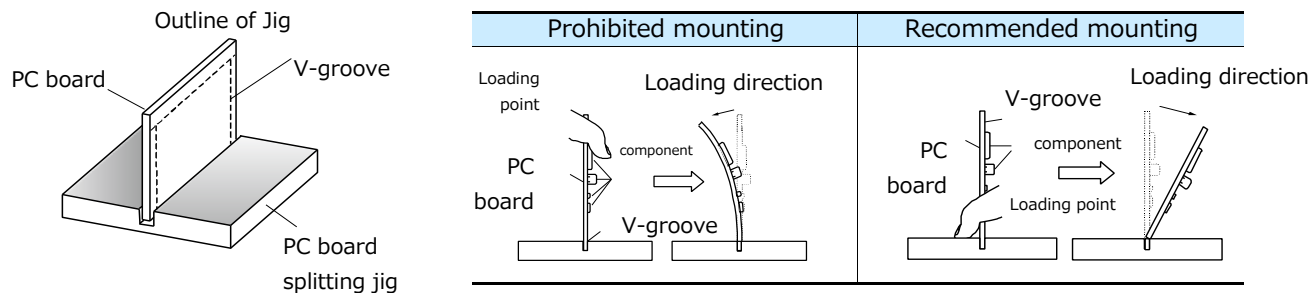

10. Mechanical Impact

- (1) The Varistors shall be free from any excessive mechanical impact. The Varistor body is made of ceramics and may be damaged or cracked if dropped. Never use a Varistor which has been dropped; their quality may already be impaired, and in that case, failure rate will increase.
- (2) When handling PC boards with Varistors mounted on them, do not allow the Varistors to collide with another PC board. When mounted PC boards are handled or stored in a stacked state, the corner of a PC board might strike Varistors, and the impact of the strike may cause damage or cracking and can deteriorate the withstand voltage and insulation resistance of the Varistor.

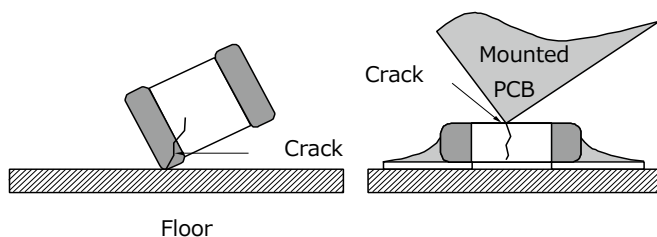

11. Do not reuse this product after removal from the mounting board.

Precautions for discarding

As to the disposal of the Varistors, check the method of disposal in each country or region where the modules are incorporated in your products to be used.

Other

The various precautions described above are typical. For special mounting conditions, please contact us.

Applicable laws and regulations , others

1. This product not been manufactured with any ozone depleting chemical controlled under the Montreal Protocol.
2. This product comply with RoHS(Restriction of the use of certain Hazardous Substance in electrical and electronic equipment) (DIRECTIVE 2011/65/EU and 2015/863/EU).
3. All the materials used in this part are registered material under the Law Concerning the Examination and Regulation of Manufacture, etc. of Chemical Substance.
4. If you need the notice by letter of "A preliminary judgement on the Laws of Japan foreign exchange and Foreign Trade Control", be sure to let us know.
5. These products are not dangerous goods on the transportation as identified by UN (United nations) numbers or UN classification.
6. The technical information in this catalog provides example of our products' typical operations and application circuit. We do not guarantee the non-infringement of third party's intellectual property rights and we do not grant any license, Right or interest in our intellectual property.

AEC-Q200 Compliant

The products are tested based on all or part of the test conditions and methods defined in AEC-Q200. Please consult with Panasonic for the details of the product specification and specific evaluation test results, etc., and please review and approve Panasonic's product specification before ordering.

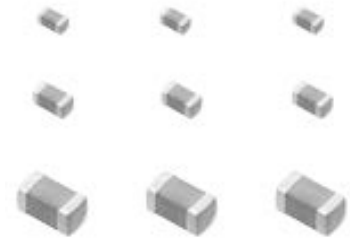

Multilayer Varistor for ESD pulse
[DC voltage lines/High speed signal lines]
Series: **EZJZ, EZJP**

Features

- Excellent ESD suppression due to original advanced material technology
- Having large electrostatic resistance meeting IEC61000-4-2, Level 4 standard
- Having no polarity (bipolar) facilitated replacing Zener Diodes. Capable of replacing 2 Zener Diodes and 1 Capacitor.
- Lead-free plating terminal electrodes enabling great solderability
- Wide range of products is available by adopting multilayer structure, meeting various needs
- Low capacitance versions for DC voltage lines of high speed busses
- Ultra low capacitance for high speed signal line
- Applicable to high-speed signal lines, such as interfaces (e.g. USB2.0, IEEE1394, HDMI, and so on), due to our original ultra-low capacitance technology.
- RoHS compliant

■ As for Packaging Methods, Handling Precautions Please see Data Files

Explanation of Part Numbers

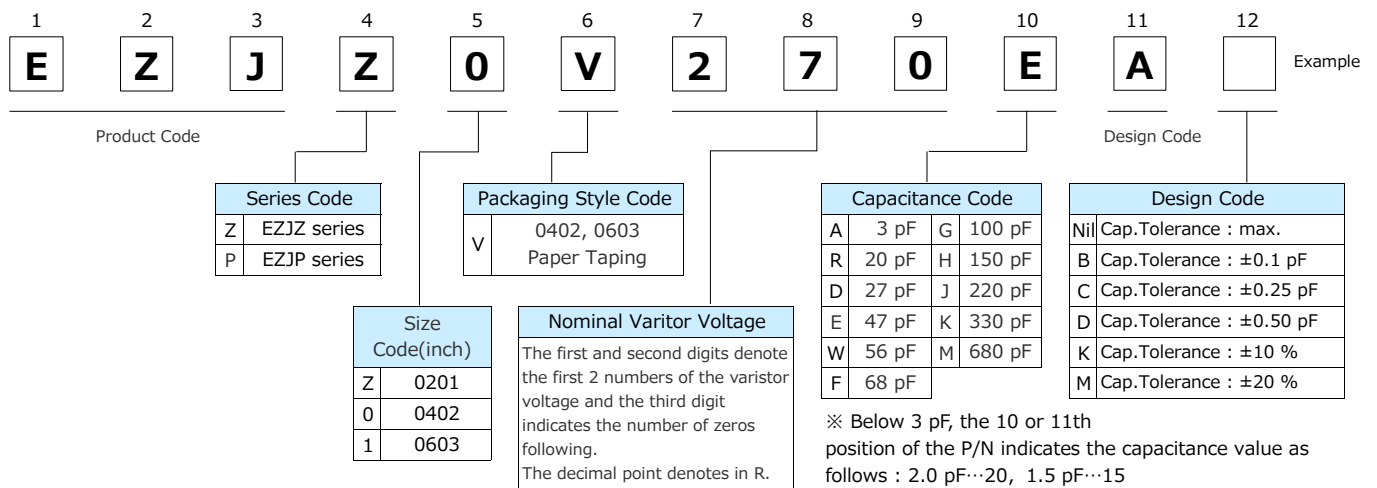

Construction

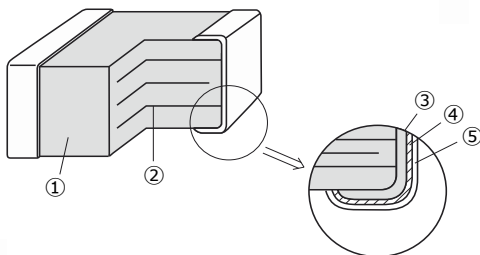

| No. | Name |
|-----|-------------------------|
| ① | Semiconductive Ceramics |
| ② | Internal electrode |
| ③ | Substrate electrode |
| ④ | Terminal electrode |
| ⑤ | Intermediate electrode |
| | External electrode |

Dimensions in mm (not to scale)

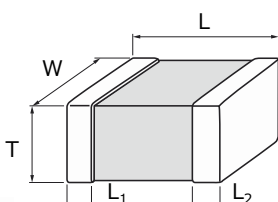

| Size Code | Size(inch) | L | W | T | L ₁ , L ₂ |
|-----------|------------|-----------|-----------|-----------|---------------------------------|
| Z | 0201 | 0.60±0.03 | 0.30±0.03 | 0.30±0.03 | 0.15±0.05 |
| 0 | 0402 | 1.00±0.05 | 0.50±0.05 | 0.50±0.05 | 0.2±0.1 |
| 1 | 0603 | 1.6±0.1 | 0.8±0.1 | 0.8±0.1 | 0.3±0.2 |

Multilayer Varistor, Low Capacitance Type [High speed signal lines]

Features

- Applicable to high-speed signal lines, such as interfaces (e.g. USB 2.0, IEEE1394, HDMI, and so on), due to our original material technology and multilayer technology.
- Capacitance : 0.8 to 2.1 pF typ.

Recommended Applications

| | |
|--------------|-------------------------------|
| Mobile phone | Antenna circuit, External IF |
| DSC,DVC | USB2.0, IEEE1394 |
| PC,PDA | USB2.0, IEEE1394, LAN1000BASE |
| TV,DVD | USB2.0, IEEE1394, HDMI |
| Game console | Controller, External IF |

Ratings and Characteristics

| Size(inch) | Part No. | Maximum allowable voltage DC (V) | Nominal varistor voltage at 1 mA (V) | Capacitance at 1 MHz (pF) | Maximum ESD IEC61000-4-2 |
|------------|--------------|----------------------------------|--------------------------------------|---------------------------|--------------------------|
| 0402 | EZJZ0V80010 | 10 | 80 | 1 max. [0.8 typ.] | Contact discharge : 8 kV |
| | EZJZ0V80015D | 5 | 80 | 1.5±0.5 | |
| | EZJZ0V500AA | 5 | 50 | 3 max. [2.1 typ.] | |
| | EZJZ0V800AA | 18 | 80 | 3 max. [2.1 typ.] | |
| | EZJZ0V171AA | 18 | 170 | 3 max. [2.1 typ.] | |
| 0603 | EZJZ1V80010 | 10 | 80 | 1 max. [0.8 typ.] | |
| | EZJZ1V500AA | 5 | 50 | 3 max. [2.1 typ.] | |
| | EZJZ1V800AA | 18 | 80 | 3 max. [2.1 typ.] | |
| | EZJZ1V171AA | 18 | 170 | 3 max. [2.1 typ.] | |

- Operating Temperature Range : -40 to 85 °C
- * Recommend soldering method : Reflow soldering

Voltage vs. Current

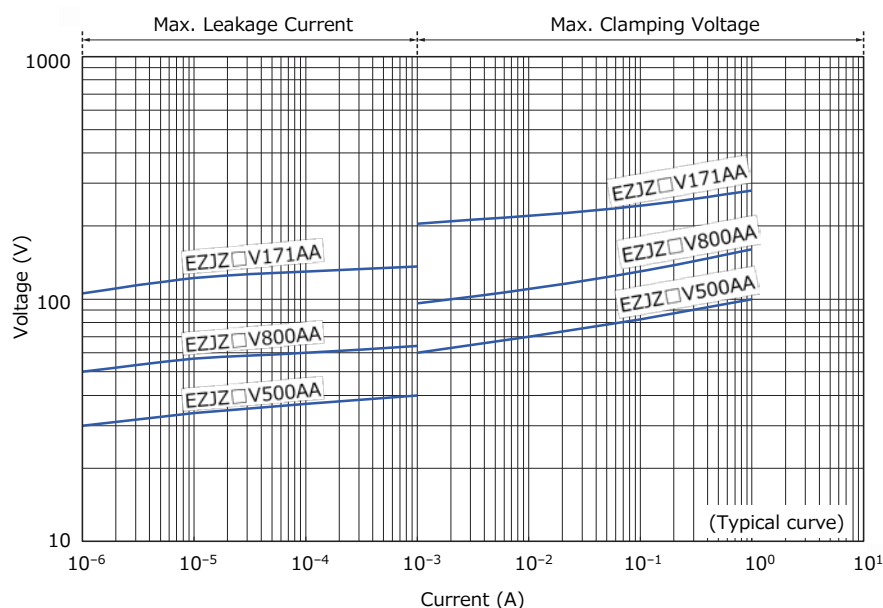

Capacitance vs. Frequency

Impedance vs. Frequency

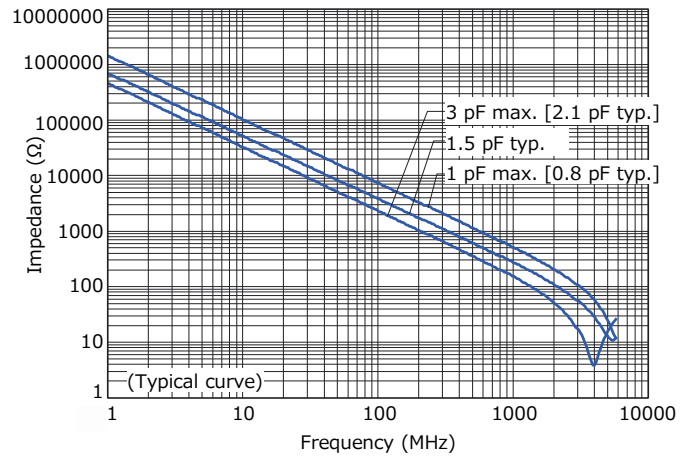
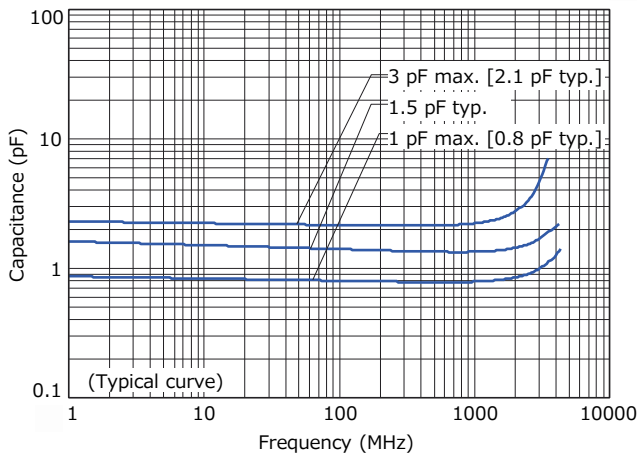

Attenuation vs. Frequency

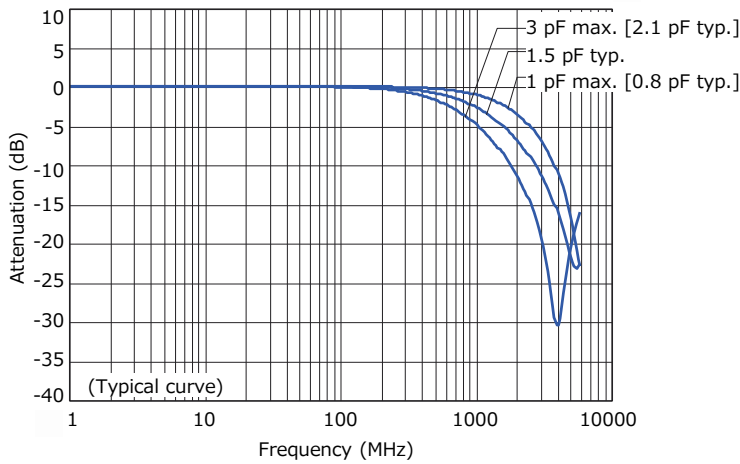

Multilayer Varistor, Low Voltage Type (Standard Type) [DC voltage lines/Low speed signal lines]

Features

Wide variety of products is available by adopting multilayer construction, which achieved wide range of usage, such as application to DC voltage lines and signal lines.

- Varistor voltage : 6.8 to 65 V (at 1 mA)
- Capacitance : 8.5 to 420 pF typ. (at 1 MHz)

● Circuit voltage

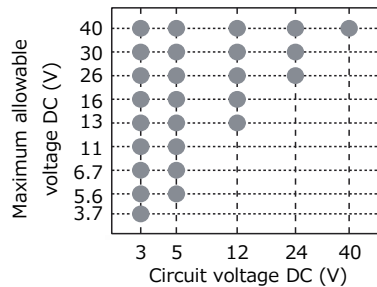

Recommended Applications

| | |
|--------------|--|
| Mobile phone | SW, LCD, LED, Audio terminal, Battery pack, Memory card, External IF |
| DSC,DVC | SW, LCD, LED, USB |
| PC,PDA | SW, LCD, LED, USB |
| TV,DVD | Audio, Video terminal |
| Audio | Audio terminal, Microphone, Receiver |
| Game console | Controller, External IF |

Ratings and Characteristics

| Size (inch) | Part No. | Maximum allowable voltage DC (V) | Nominal varistor voltage at 1 mA (V) | Capacitance (pF) | | Maximum peak current at 8/20 μs, 2 times (A) | Maximum ESD IEC61000-4-2 |
|-------------|-------------|----------------------------------|--------------------------------------|---------------------|-----------|--|--------------------------|
| | | | | at 1 MHz | at 1 kHz | | |
| 0201 | EZJPZV6R8JA | 3.7 | 6.8 | 220 max. [150 typ.] | 175 typ. | 5 | Contact discharge :8 kV |
| | EZJPZV6R8GA | 3.7 | 6.8 | 100 max. [85 typ.] | 100 typ. | 5 | |
| | EZJPZV080GA | 5.6 | 8 | 100 max. [85 typ.] | 100 typ. | 5 | |
| | EZJPZV120GA | 7.5 | 12 | 100 max. [85 typ.] | 100 typ. | 5 | |
| | EZJPZV120DA | 7.5 | 12 | 27 max. [22 typ.] | 33 typ. | 1 | |
| | EZJPZV120RA | 7.5 | 12 | 20 max. [15 typ.] | 18 typ. | 1 | |
| | EZJPZV150RA | 9 | 15 | 20 max. [15 typ.] | 18 typ. | 1 | |
| | EZJPZV270RA | 16 | 27 | 20 max. [15 typ.] | 16.5 typ. | 1 | |
| 0402 | EZJPZV270BA | 16 | 27 | 10 max. [8.5 typ.] | 10 typ. | 1 | |
| | EZJP0V6R8MA | 3.7 | 6.8 | 680 max. [420 typ.] | 650 typ. | 20 | |
| | EZJP0V6R8GA | 3.7 | 6.8 | 100 max. [85 typ.] | 100 typ. | 3 | |
| | EZJP0V080MA | 5.6 | 8 | 680 max. [420 typ.] | 650 typ. | 20 | |
| | EZJP0V080KA | 5.6 | 8 | 330 max. [290 typ.] | 480 typ. | 15 | |
| | EZJP0V080GA | 5.6 | 8 | 100 max. [65 typ.] | 100 typ. | 3 | |
| | EZJP0V080DA | 5.6 | 8 | 27 max. [22 typ.] | 33 typ. | 1 | |
| | EZJP0V120JA | 6.7 | 12 | 220 max. [150 typ.] | 175 typ. | 10 | |
| | EZJZ0V180HA | 11 | 18 | 150 max. [120 typ.] | 140 typ. | 10 | |
| | EZJZ0V220HA | 13 | 22 | 150 max. [100 typ.] | 116 typ. | 10 | |
| | EZJP0V270EA | 16 | 27 | 47 max. [33 typ.] | 37 typ. | 4 | |
| | EZJP0V270RA | 16 | 27 | 20 max. [15 typ.] | 16.5 typ. | 1 | |
| 0603 | EZJZ0V420WA | 30 | 42 | 56 max. [40 typ.] | 45 typ. | 10 | |
| | EZJZ0V650DA | 40 | 65 | 27 max. [22 typ.] | 33 typ. | 5 | |
| | EZJP1V120KA | 6.7 | 12 | 330 max. [250 typ.] | 290 typ. | 20 | |
| | EZJZ1V180JA | 11 | 18 | 220 max. [180 typ.] | 210 typ. | 20 | |
| | EZJZ1V220JA | 13 | 22 | 220 max. [160 typ.] | 185 typ. | 20 | |
| | EZJZ1V270GA | 16 | 27 | 100 max. [85 typ.] | 100 typ. | 20 | |
| | EZJZ1V270EA | 16 | 27 | 47 max. [33 typ.] | 37 typ. | 20 | |
| | EZJZ1V270RA | 16 | 27 | 20 max. [15 typ.] | 16.5 typ. | 3 | |
| | EZJZ1V330GA | 26 | 33 | 100 max. [85 typ.] | 100 typ. | 20 | |
| | EZJZ1V420FA | 30 | 42 | 68 max. [55 typ.] | 63 typ. | 15 | |
| EZJZ1V650DA | 40 | 65 | 27 max. [22 typ.] | 33 typ. | 5 | | |

● Operating Temperature Range : -40 to 85 °C

* Recommend soldering method : Reflow soldering

| | |
|---------------------------|--|
| Maximum Allowable Voltage | Maximum DC Voltage that can be applied continuously within the operating temperature range |
| Varistor Voltage | Varistor starting voltage between terminals at DC 1 mA, also known as Breakdown voltage |
| Maximum Peak Current | Maximum current that can be withstood under the standard pulse 8/20 μs, 2 times based |
| Maximum ESD | Maximum voltage that can be withstood under ESD based on IEC61000-4-2, 10 times (5 times of each positive-negative polarity) |

Voltage vs. Current

● EZJP Series

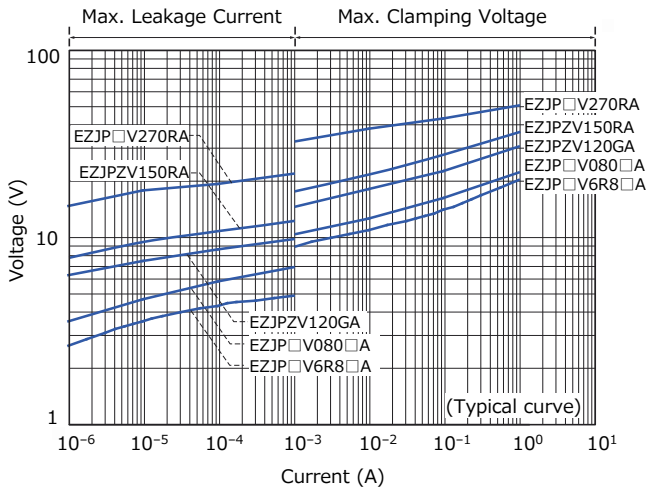

● EZJZ Series

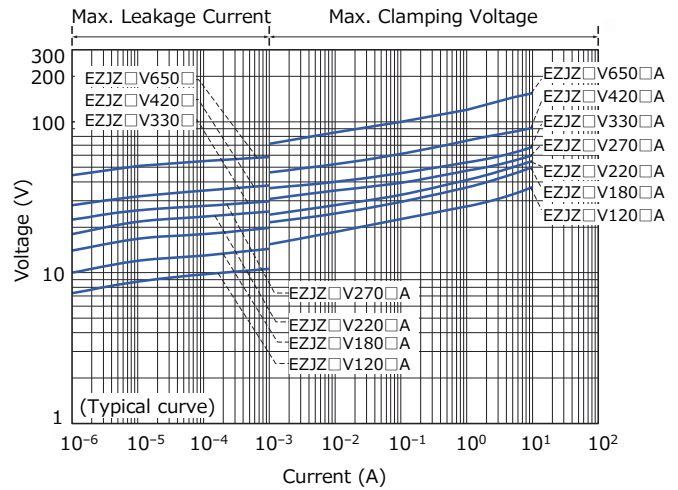

Capacitance vs. Frequency

● EZJP Series

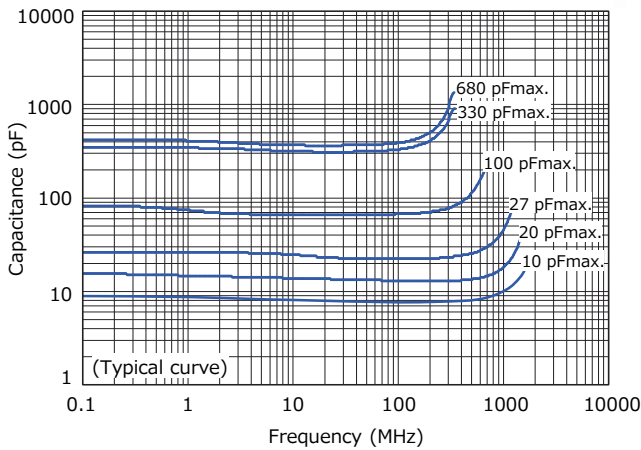

● EZJZ Series

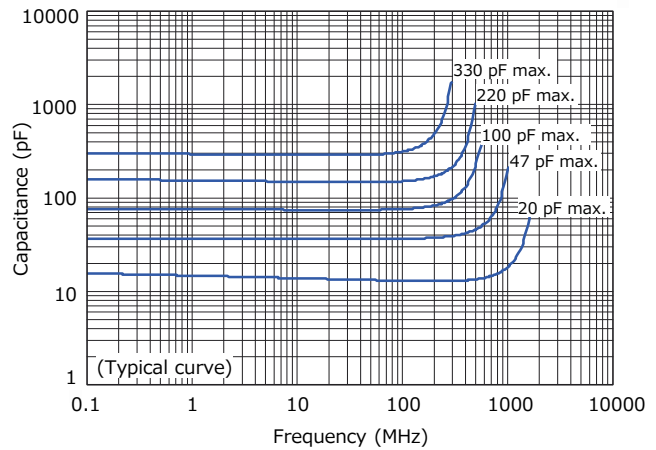

Attenuation vs. Frequency

● EZJP Series

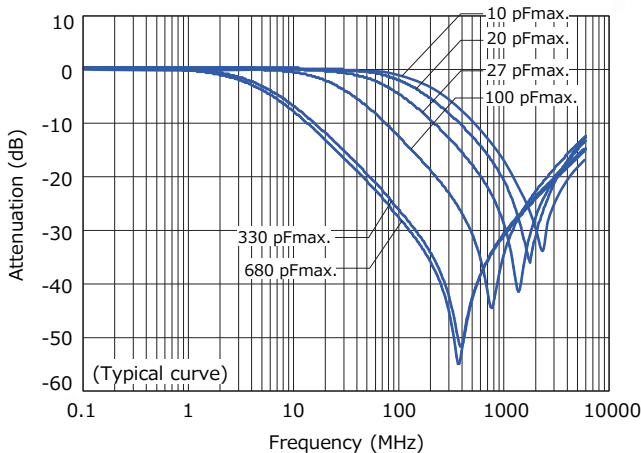

● EZJZ Series

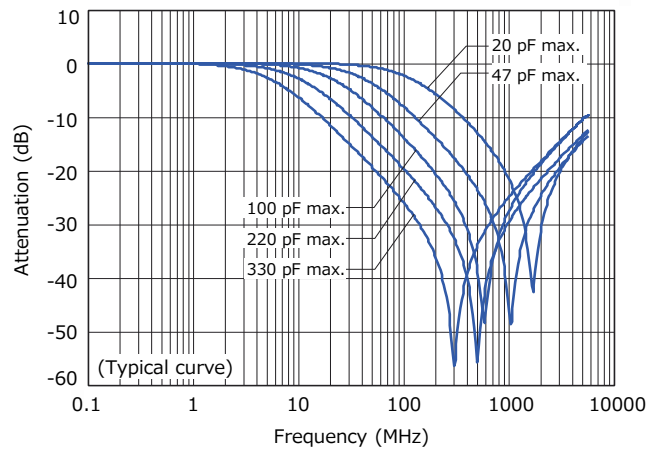



Multilayer Varistor for ESD pulse [DC voltage lines]

Series: **EZJS**

Features

- Excellent ESD suppression due to original advanced material technology
- Having large electrostatic resistance meeting IEC61000-4-2, Special Level 30 kV standard
- Having no polarity (bipolar) facilitated replacing Zener Diodes. Capable of replacing 2 Zener Diodes and 1 Capacitor.
- Lead-free plating terminal electrodes enabling great solderability
- RoHS compliant

■ As for Packaging Methods, Handling Precautions Please see Data Files

Explanation of Part Numbers

| | | | | | | | | | | | | |
|--------------|----------|----------|-------------|----------|----------|----------|----------|----------|----------|-------------|----|---------|
| 1 | 2 | 3 | 4 | 5 | 6 | 7 | 8 | 9 | 10 | 11 | 12 | Example |
| E | Z | J | S | 2 | Y | D | 4 | 7 | 2 | | | |
| Product Code | | | Series Code | | | | | | | Design Code | | |

| Series Code | 1 0603 | 2 0805 |
|----------------------|------------------------------|---------------------------------|
| Packaging Style Code | V φ 180 reel, Paper Taping | Y φ 180 reel, Embossed Taping |

| Max. Allowable Voltage Code | B DC 6 V | C DC 18 V | D DC 30 V |
|-----------------------------|------------|-------------|-------------|
|-----------------------------|------------|-------------|-------------|

| Nominal Varistor Voltage | The first and second digits denote the first 2 numbers of the varistor voltage and the third digit indicates the number of zeros following. | |
|--------------------------|---|--|
|--------------------------|---|--|

Construction

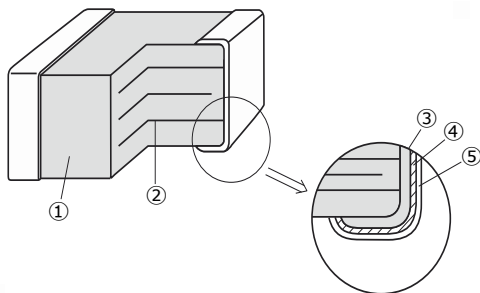

| No. | Name | |
|-----|-------------------------|------------------------|
| ① | Semiconductive Ceramics | |
| ② | Internal electrode | |
| ③ | Terminal electrode | Substrate electrode |
| ④ | | Intermediate electrode |
| ⑤ | | External electrode |

Dimensions in mm (not to scale)

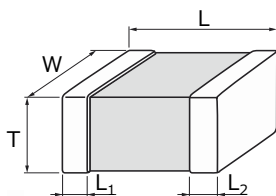

| Size Code | Size(inch) | L | W | T | L ₁ , L ₂ |
|-----------|------------|-----------|-----------|----------------------|---------------------------------|
| 1 | 0603 | 1.60±0.15 | 0.8±0.1 | 0.8±0.1 | 0.3±0.2 |
| 2 | 0805 | 2.0±0.2 | 1.25±0.20 | 0.8±0.2 1.25±0.20 | 0.50±0.25 |

Ratings and Characteristics

| Size(inch) | Part No. | Maximum allowable voltage DC (V) | Nominal varistor voltage at 0.1 mA (V) | Capacitance at 1 kHz (pF) | Maximum ESD IEC61000-4-2 |
|------------|------------|----------------------------------|--|---------------------------|------------------------------|
| 0603 | EZJS1VB822 | 6 | 12 | 8200 typ. | Contact discharge : 30 kV |
| | EZJS1VC392 | 18 | 30 | 3900 typ. | |
| | EZJS1VD182 | 30 | 50 | 1800 typ. | |
| 0805 | EZJS2VB223 | 6 | 12 | 22000 typ. | |
| | EZJS2YC822 | 18 | 30 | 8200 typ. | |
| | EZJS2YD472 | 30 | 50 | 4700 typ. | |

● Operating Temperature Range : -40 to 85 °C

* Avoid flow soldering.

Voltage vs. Current

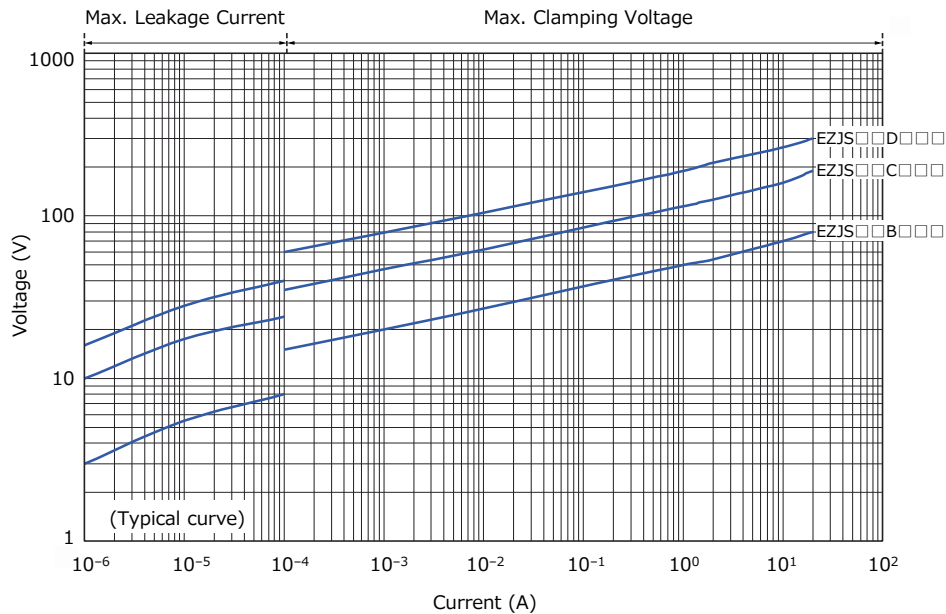

Capacitance vs. Frequency

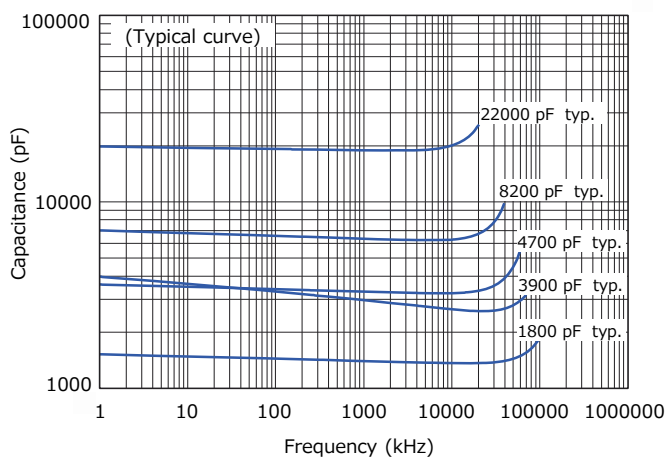

Attenuation vs. Frequency

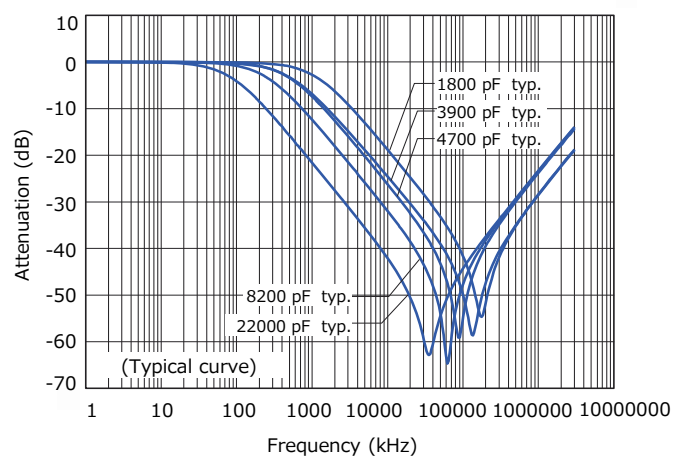

Varistor Characteristics and Equivalent Circuit

A Multilayer Varistor does not have an electrical polarity like zener diodes and is equivalent to total 3 pcs of 2 zener diodes and 1 capacitor.

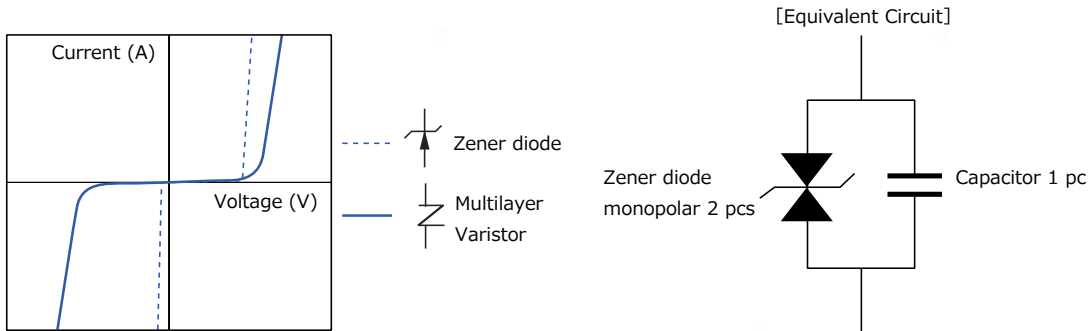

ESD Suppressive Effects

Typical effects of ESD suppression

Test conditions :

IEC61000-4-2* Level4 Contact discharge, 8 kV

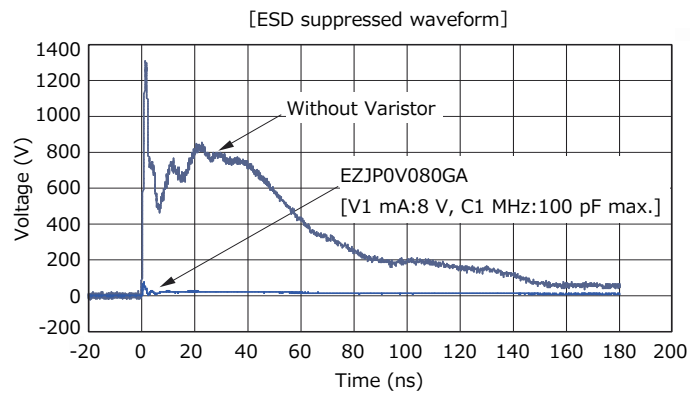
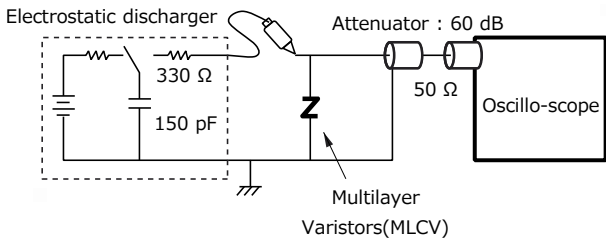

*IEC61000-4-2 ... International Standard of the ESD testing method (HBM) for electronic equipment ability to withstand ESD generated from a human body. It sets 4 levels of severity

| Severity | Level 1 | Level 2 | Level 3 | Level 4 |
|-------------------|---------|---------|---------|---------|
| Contact discharge | 2 kV | 4 kV | 6 kV | 8 kV |
| Air discharge | 2 kV | 4 kV | 8 kV | 15 kV |

Replacement of Zener diode

Replacing "Zener diode and Capacitor" with Multilayer Varistor saves both the mounting area and number of components used.

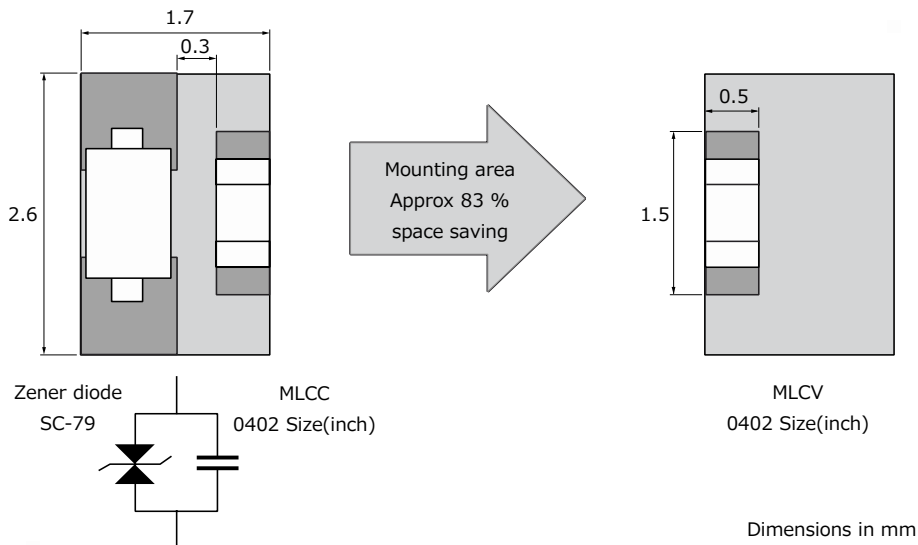

Recommended Applications

| Applications | Series | Circuit | | | |
|---|----------------|---|--|----|---------|
| | | DC | 1k | 1M | 1G (Hz) |
| Mobile phones, DSC, PC, PDA, HDD TV(PDP, LC etc.), DVD, DVC, Game consoles, Audio equipment | EZJZ, P Series | Ultra low capacitance (Cap. : 3 pF or less) | [Bar chart showing high performance from DC to GHz] | | |
| | | Low capacitance (Cap. : 20 to 680 pF) | [Bar chart showing performance from DC to tens of Hz] | | |
| PWR, Photoelectric sensors, SSR, Motors, Pressure sensors, Proximity switches | EZJS Series | High capacitance (Cap. : 1800 to 22000 pF) | [Bar chart showing performance from DC to several kHz] | | |

Applications

● Mobile Phone

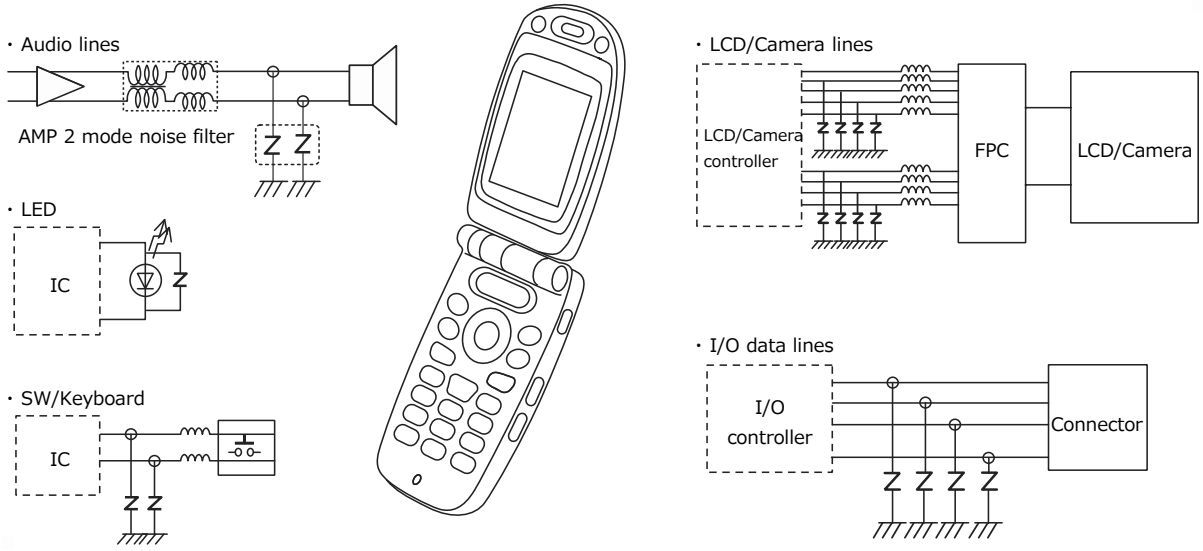

● USB1.1/2.0 lines

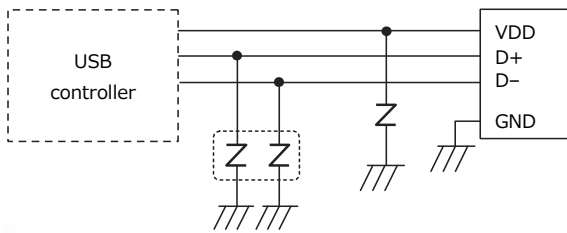

● IEEE1394 lines

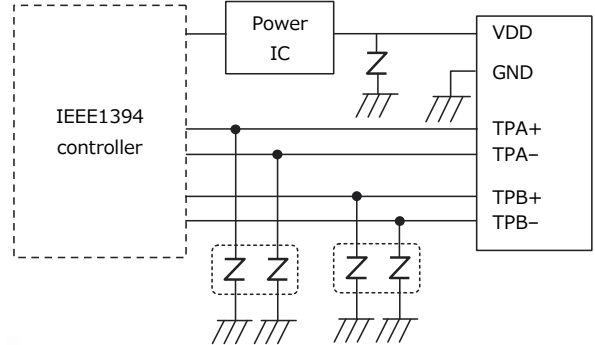

● HDMI lines

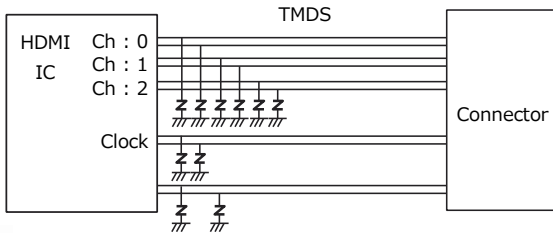

Performance and Testing Methods

| Characteristics | Specifications | Testing Method | | | | | | | | | | | | | | | |
|--------------------------------------|--------------------------------------|---|------|-------------|--------|---|----------------------|----------------|---|----------------|------------|---|----------------------|----------------|---|----------------|------------|
| Standard test conditions | | Electrical characteristics shall be measured under the following conditions. Temp. : 5 to 35 °C, Relative humidity : 85 % or less | | | | | | | | | | | | | | | |
| Varistor voltage | To meet the specified value. | The Varistor voltage is the voltage (V_{C_r} or V_{CmA}) between both end terminals of a Varistor when specified current (CmA) is applied to it. The measurement shall be made as quickly as possible to avoid heating effects. | | | | | | | | | | | | | | | |
| Maximum allowable voltage | To meet the specified value. | The maximum DC voltage that can be applied continuously to a varistor. | | | | | | | | | | | | | | | |
| Capacitance | To meet the specified value. | Capacitance shall be measured at the specified frequency, bias voltage 0 V, and measuring voltage 0.2 to 2.0 Vrms | | | | | | | | | | | | | | | |
| Maximum peak current | To meet the specified value. | The maximum current measured (Varistor voltage tolerance is within $\pm 10\%$) when a standard impulse current of 8/20 μ seconds is applied twice with an interval of 5 minutes. | | | | | | | | | | | | | | | |
| Maximum ESD | To meet the specified value. | The maximum ESD measured (while the varistor voltage is within $\pm 30\%$ of its nominal value) when exposed to ESD 10 times (five times for each positive-negative polarity) based on IEC61000-4-2. | | | | | | | | | | | | | | | |
| Solder ability | To meet the specified value. | The part shall be immersed into a soldering bath under the conditions below. Solder : Sn-3.0Ag-0.5Cu Soldering flux : Ethanol solution of rosin (Concentration approx. 25 wt%) Soldering temp. : 230 \pm 5 °C Period : 4 \pm 1 s Soldering position : Immerse both terminal electrodes until they are completely into the soldering bath. | | | | | | | | | | | | | | | |
| Resistance to soldering heat | $\Delta V_c/V_c$: within $\pm 10\%$ | After the immersion, leave the part for 24 \pm 2 hours under the standard condition, then evaluate its characteristics. Soldering conditions are specified below: Soldering conditions : 270 °C , 3 s / 260 °C , 10 s Soldering position : Immerse both terminal electrodes until they are completely into the soldering bath. | | | | | | | | | | | | | | | |
| Temperature cycling | $\Delta V_c/V_c$: within $\pm 10\%$ | After repeating the cycles stated below for specified number of times, leave the part for 24 \pm 2 hours, then evaluate its characteristics. Cycle : 5 cycles <table border="1" style="margin-left: auto; margin-right: auto;"> <thead> <tr> <th>Step</th> <th>Temperature</th> <th>Period</th> </tr> </thead> <tbody> <tr> <td>1</td> <td>Max. Operating Temp.</td> <td>30\pm3 min</td> </tr> <tr> <td>2</td> <td>Ordinary temp.</td> <td>3 min max.</td> </tr> <tr> <td>3</td> <td>Min. Operating Temp.</td> <td>30\pm3 min</td> </tr> <tr> <td>4</td> <td>Ordinary temp.</td> <td>3 min max.</td> </tr> </tbody> </table> | Step | Temperature | Period | 1 | Max. Operating Temp. | 30 \pm 3 min | 2 | Ordinary temp. | 3 min max. | 3 | Min. Operating Temp. | 30 \pm 3 min | 4 | Ordinary temp. | 3 min max. |
| Step | Temperature | Period | | | | | | | | | | | | | | | |
| 1 | Max. Operating Temp. | 30 \pm 3 min | | | | | | | | | | | | | | | |
| 2 | Ordinary temp. | 3 min max. | | | | | | | | | | | | | | | |
| 3 | Min. Operating Temp. | 30 \pm 3 min | | | | | | | | | | | | | | | |
| 4 | Ordinary temp. | 3 min max. | | | | | | | | | | | | | | | |
| Biased Humidity | $\Delta V_c/V_c$: within $\pm 10\%$ | After conducting the test under the conditions specified below, leave the part 24 \pm 2 hours, then evaluate its characteristics. Temp. : 40 \pm 2 °C Humidity : 90 to 95 %RH Applied voltage : Maximum allowable voltage (Individually specified) Period : 500+24/0 h | | | | | | | | | | | | | | | |
| High temperature exposure (dry heat) | $\Delta V_c/V_c$: within $\pm 10\%$ | After conducting the test under the conditions specified below, leave the part 24 \pm 2 hours, then evaluate its characteristics. Temp. : Maximum operating temperature ± 3 °C (Individually specified) Applied voltage : Maximum allowable voltage (Individually specified) Period : 500+24/0 h | | | | | | | | | | | | | | | |

Packaging Methods (Taping)

● Standard Quantity

| Series | Size Code (inch size) | Thickness (mm) | Kind of Taping | Pitch (mm) | Quantity (pcs/reel) |
|------------|-----------------------|----------------|-------------------------|------------|---------------------|
| EZJZ, EZJP | Z(0201) | 0.3 | Pressed Carrier Taping | 2 | 15,000 |
| | 0(0402) | 0.5 | | | 10,000 |
| | 1(0603) | 0.8 | Punched Carrier Taping | 4 | 4,000 |
| EZJS | 1(0603) | 0.8 | | | 4,000 |
| | 2(0805) | 0.8 | | | 5,000 |
| | | 1.25 | Embossed Carrier Taping | | 2,000 |

● 2 mm Pitch (Pressed Carrier Taping) Size 0201

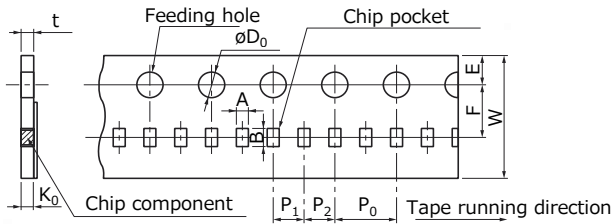

| | A | B | W | F | E | P ₁ | P ₂ | P ₀ | øD ₀ | t | K ₀ |
|-----------|------------|------------|----------|------------|------------|----------------|----------------|----------------|-----------------|----------|----------------|
| Unit (mm) | 0.36 ±0.03 | 0.66 ±0.03 | 8.0 ±0.2 | 3.50 ±0.05 | 1.75 ±0.10 | 2.00 ±0.05 | 2.00 ±0.05 | 4.0 ±0.1 | 1.5 +0.1 / 0 | 0.55 max | 0.36 ±0.03 |

● 4 mm pitch (Embossed Carrier Taping) Size 0805

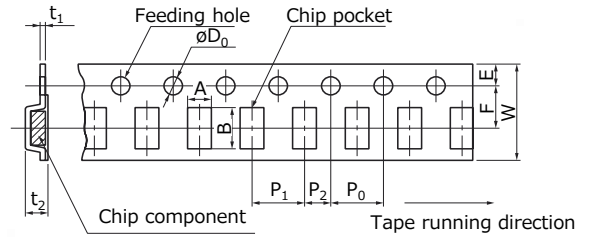

| | A | B | W | F | E | P ₁ | P ₂ | P ₀ | øD ₀ | t ₁ | t ₂ |
|-----------|------------|------------|----------|------------|------------|----------------|----------------|----------------|-----------------|----------------|----------------|
| Unit (mm) | 1.55 ±0.20 | 2.35 ±0.20 | 8.0 ±0.2 | 3.50 ±0.05 | 1.75 ±0.10 | 4.0 ±0.1 | 2.00 ±0.05 | 4.0 ±0.1 | 1.5 +0.1 / 0 | 0.6 max | 1.5 max |

● 2 mm Pitch (Punched Carrier Taping) Size 0402

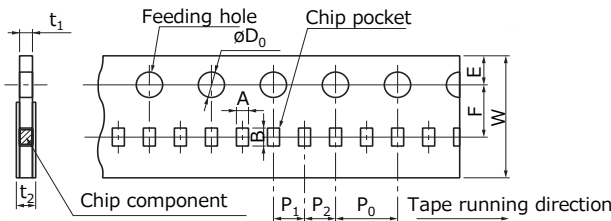

| | A | B | W | F | E | P ₁ | P ₂ | P ₀ | øD ₀ | t ₁ | t ₂ |
|-----------|------------|------------|----------|------------|------------|----------------|----------------|----------------|-----------------|----------------|----------------|
| Unit (mm) | 0.62 ±0.05 | 1.12 ±0.05 | 8.0 ±0.2 | 3.50 ±0.05 | 1.75 ±0.10 | 2.00 ±0.05 | 2.00 ±0.05 | 4.0 ±0.1 | 1.5 +0.1 / 0 | 0.7 max | 1.0 max |

● Reel for Taping

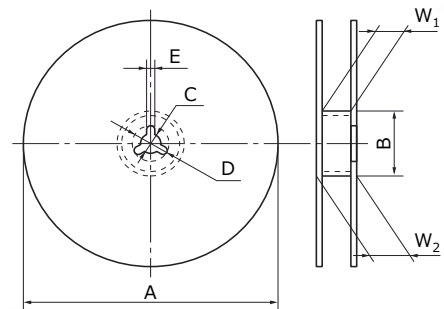

| | A | B | C | D | E | W ₁ | W ₂ |
|-----------|---------------------------------|------------------------------------|----------|----------|---------|----------------------------------|----------------|
| Unit (mm) | ø180 ⁰ ₋₃ | ø60.0 ^{+1.0} ₀ | 13.0±0.5 | 21.0±0.8 | 2.0±0.5 | 9.0 ^{+1.0} ₀ | 11.4±1.0 |

● 4 mm Pitch (Punched Carrier Taping) Size 0603, 0805, 0504/2 Array

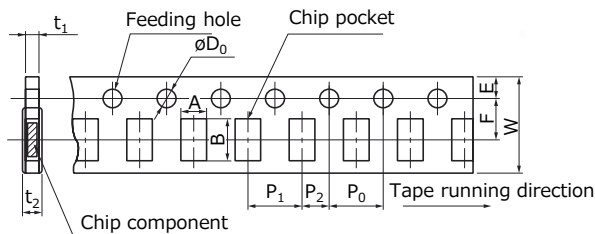

| Size Code (inch size) | A | B | W | F | E | P ₁ | P ₂ | P ₀ | øD ₀ | t ₁ | t ₂ |
|-----------------------|------------|------------|----------|------------|------------|----------------|----------------|----------------|-----------------|----------------|----------------|
| 1 (0603) | 1.0 ±0.1 | 1.8 ±0.1 | | | | | | | | | |
| S (0504 2 Array) | 1.18 ±0.10 | 1.63 ±0.10 | 8.0 ±0.2 | 3.50 ±0.05 | 1.75 ±0.10 | 4.0 ±0.1 | 2.00 ±0.05 | 4.0 ±0.1 | 1.5 +0.1 / 0 | 1.1 max | 1.4 max |
| 2 (0805) | 1.65 ±0.20 | 2.4 ±0.2 | | | | | | | | | |

● Leader Part and Taped End

Leader part

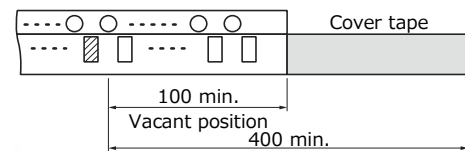

Tape end

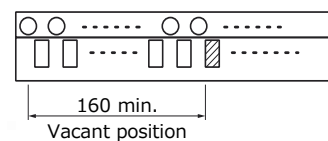

Unit (mm)

Multilayer Varistors, Chip Type

Series: EZJZ, EZJP (For DC voltage lines, high speed signal lines)

Series: EZJS (For DC voltage lines)

Handling Precautions

[Precautions]

- **Do not use the products beyond the descriptions in this product catalog.**
- **This product catalog guarantees the quality of the products as individual components. Before you use the products, please make sure to check and evaluate the products in the circumstance where they are installed in your product.**

Safety Precautions

Multilayer Varistors (hereafter referred to as “Varistors”) should be used for general purpose applications as countermeasures against ESD and noise found in consumer electronics (audio/visual, home, office, information & communication) equipment. When subjected to severe electrical, environmental, and/or mechanical stress beyond the specifications, as noted in the Ratings and Specified Conditions section, the Varistors’ performance may be degraded, or become failure mode, such as short circuit mode and open-circuit mode.

If you use under the condition of short-circuit, heat generation of Varistors will occur by running large current due to application of voltage. There are possibilities of smoke emission, substrate burn-out, and, in the worst case, fire. For products which require high safety levels, please carefully consider how a single malfunction can affect your product. In order to ensure the safety in the case of a single malfunction, please design products with fail-safe, such as setting up protecting circuits, etc.

We are trying to improve the quality and the reliability, but the durability differs depending on the use environment and the use conditions. On use, be sure to confirm the actual product under the actual use conditions.

- For the following applications and conditions, please be sure to consult with our sales representative in advance and to exchange product specifications which conform to such applications.
 - When your application may have difficulty complying with the safety or handling precautions specified below.
 - High-quality and high-reliability required devices that have possibility of causing hazardous conditions, such as death or injury (regardless of directly or indirectly), due to failure or malfunction of the product.
 - ① Aircraft and Aerospace Equipment (artificial satellite, rocket, etc.)
 - ② Submarine Equipment (submarine repeating equipment, etc.)
 - ③ Transportation Equipment (motor vehicles, airplanes, trains, ship, traffic signal controllers, etc.)
 - ④ Power Generation Control Equipment
(atomic power, hydroelectric power, thermal power plant control system, etc.)
 - ⑤ Medical Equipment (life-support equipment, pacemakers, dialysis controllers, etc.)
 - ⑥ Information Processing Equipment (large scale computer systems, etc.)
 - ⑦ Electric Heating Appliances, Combustion devices (gas fan heaters, oil fan heaters, etc.)
 - ⑧ Rotary Motion Equipment
 - ⑨ Security Systems
 - ⑩ And any similar types of equipment

Strict Observance

1. Confirmation of Rated Performance

The Varistors shall be operated within the specified rating/performance.

Applications exceeding the specifications may cause deteriorated performance and/or breakdown, resulting in degradation and/or smoking or ignition of products. The following are strictly observed.

- (1) The Varistors shall not be operated beyond the specified operating temperature range.
- (2) The Varistors shall not be operated in excess of the specified maximum allowable voltage.
- (3) The Varistors shall not be operated in the circuits to which surge current and ESD that exceeds the specified maximum peak current and maximum ESD.
- (4) Never use for AC power supply circuits.

2. The Varistors shall not be mounted near flammables.

Operating Conditions and Circuit Design

1. Circuit Design

1.1 Operating Temperature and Storage Temperature

When operating a components-mounted circuit, please be sure to observe the "Operating Temperature Range", written in delivery specifications. Storage temperature of PCB after mounting Varistors, which is not operated, should be within the specified "Storage Temperature Range" in the delivery specifications. Please remember not to use the product under the condition that exceeds the specified maximum temperature.

1.2 Operating Voltage

The Varistors shall not be operated in excess of the "Maximum allowable voltage". If the Varistors are operated beyond the specified Maximum allowable voltage, it may cause short and/or damage due to thermal run away. The circuit that continuously applies high frequency and/or steep pulse voltage please examines the reliability of the Varistor even if it is used within a "Maximum allowable voltage". Also, it would be safer to check also the safety and reliability of your circuit.

1.3 Self-heating

The surface temperature of the Varistors shall be under the specified Maximum Operating Temperature in the Specifications including the temperature rise caused by self-heating. Check the temperature rise of the Varistor in your circuit.

1.4 Environmental Restrictions

The Varistors does not take the use under the following special environments into consideration. Accordingly, the use in the following special environments, and such environmental conditions may affect the performance of the product; prior to use, verify the performance, reliability, etc. thoroughly.

- ① Use in liquids such as water, oil, chemical, and organic solvent.
- ② Use under direct sunlight, in outdoor or in dusty atmospheres.
- ③ Use in places full of corrosive gases such as sea breeze, Cl₂, H₂S, NH₃, SO₂, and NOx.
- ④ Use in environment with large static electricity or strong electromagnetic waves or strong radial ray.
- ⑤ Where the product is close to a heating component, or where an inflammable such as a polyvinyl chloride wire is arranged close to the product.
- ⑥ Where this product is sealed or coated with resin etc.
- ⑦ Where solvent, water, or water-soluble detergent is used in flux cleaning after soldering.
(Pay particular attention to water-soluble flux.)
- ⑧ Use in such a place where the product is wetted due to dew condensation.
- ⑨ Use the product in a contaminated state.
Ex.) Do not handle the product such as sticking sebum directly by touching the product after mounting printed circuit board.
- ⑩ Under severe conditions of vibration or impact beyond the specified conditions found in the Specifications.

2. Design of Printed Circuit Board

2.1 Selection of Printed Circuit Boards

There is a possibility of performance deterioration by heat shock (temperature cycles), which causes cracks, from alumina substrate. Please confirm that the substrate you use does not deteriorate the Varistors' quality.

2.2 Design of Land Pattern

- 1) Recommended land dimensions are shown below. Use the proper amount of solder in order to prevent cracking. Using too much solder places excessive stress on the Varistors.

Recommended Land Dimensions(Ex.)

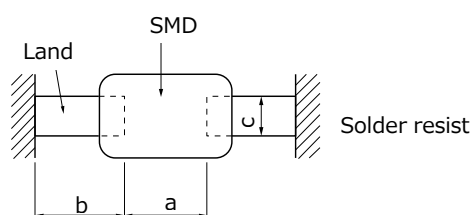

| Size Code/EIA | Component dimensions | | | Unit (mm) | | |
|------------------|----------------------|------|-------------|------------|--------------|------------|
| | L | W | T | a | b | c |
| Z(0201) | 0.6 | 0.3 | 0.3 | 0.2 to 0.3 | 0.25 to 0.30 | 0.2 to 0.3 |
| 0(0402) | 1.0 | 0.5 | 0.5 | 0.4 to 0.5 | 0.4 to 0.5 | 0.4 to 0.5 |
| 1(0603) | 1.6 | 0.8 | 0.8 | 0.8 to 1.0 | 0.6 to 0.8 | 0.6 to 0.8 |
| 2(0805) | 2.0 | 1.25 | 0.8 to 1.25 | 0.8 to 1.2 | 0.8 to 1.0 | 0.8 to 1.0 |

(2) The land size shall be designed to have equal space, on both right and left side. If the amount of solder on the right land is different from that of the left land, the component may be cracked by stress since the side with a larger amount of solder solidifies later during cooling.

Recommended Amount of Solder

(a) Excessive amount (b) Proper amount (c) Insufficient amount

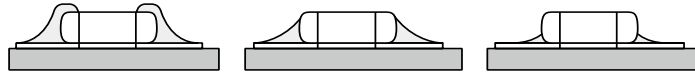

2.3 Utilization of Solder Resist

- (1) Solder resist shall be utilized to equalize the amounts of solder on both sides.
- (2) Solder resist shall be used to divide the pattern for the following cases;
 - Components are arranged closely.
 - The Varistor is mounted near a component with lead wires.
 - The Varistor is placed near a chassis.

See the table right.

Prohibited Applications and Recommended Applications

| Item | Prohibited applications | Improved applications by pattern division |
|---|--|---|
| Mixed mounting with a component with lead wires | The lead wire of a Component With lead wires | Solder resist |
| Arrangement near chassis | Chassis Solder(ground solder) Electrode pattern | Solder resist |
| Retro-fitting of component with lead wires | A lead wire of Retrofitted component Soldering iron iron | Solder resist |
| Lateral arrangement | Portion to be Excessively soldered Land | Solder resist |

2.4 Component Layout

To prevent the crack of Varistors, place it on the position that could not easily be affected by the bending stress of substrate while going through procedures after mounting or handling.

- (1) To minimize mechanical stress caused by the warp or bending of a PC board, please follow the recommended Varistors' layout below.

| Prohibited layout | Recommended layout |
|-------------------|--|
| | Layout the Varistors sideways against the stressing direction. |

- (2) The following layout is for your reference since mechanical stress near the dividing/breaking position of a PC board varies depending on the mounting position of the Varistors.

Magnitude of stress
 $A > B = C > D > E$

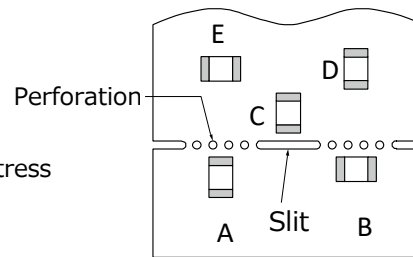

- (3) The magnitude of mechanical stress applied to the Varistors when dividing the circuit board in descending order is as follows: push back < slit < V-groove < perforation. Also take into account the layout of the Varistors and the dividing/breaking method.

2.5 Mounting Density and Spaces

Intervals between components should not be too narrow to prevent the influence from solder bridges and solder balls. The space between components should be carefully determined.

Precautions for Assembly

1. Storage

- (1) The Varistors shall be stored between 5 to 40 °C and 20 to 70 % RH, not under severe conditions of high temperature and humidity.
- (2) If stored in a place where humidity, dust, or corrosive gasses (hydrogen sulfide, sulfurous acid, hydrogen chloride and ammonia, etc.) are contained, the solderability of terminal electrodes will be deteriorated. In addition, storage in a place where the heat or direct sunlight exposure occurs will cause mounting problems due to deformation of tapes and reels and components and taping/reels sticking together.
- (3) Do not store components longer than 6 months. Check the solderability of products that have been stored for more than 6 months before use.

2. Adhesives for Mounting

- (1) The amount and viscosity of an adhesive for mounting shall be such that the adhesive will not flow off on the land during its curing.
- (2) If the amount of adhesive is insufficient for mounting, the Varistors may fall off after or during soldering.
- (3) Low-viscosity of the adhesive causes displacement of Varistors.
- (4) The heat-curing methods for adhesive are ultraviolet radiation, far-infrared radiation, and so on. In order to prevent the terminal electrodes of the Varistors from oxidizing, the curing shall be under the following conditions: 160 °C max., for 2 minutes max.
- (5) Insufficient curing may cause the Varistors to fall off after or during soldering. In addition, insulation resistance between terminal electrodes may deteriorate due to moisture absorption. In order to prevent these problems, please observe proper curing conditions.

3. Chip Mounting Consideration

- (1) When mounting the Varistors components on a PC board, the Varistor bodies shall be free from excessive impact loads such as mechanical impact or stress due to the positioning, pushing force and displacement of vacuum nozzles during mounting.
- (2) Maintenance and inspection of the Chip Mounter must be performed regularly.
- (3) If the bottom dead center of the vacuum nozzle is too low, the Varistor will crack from excessive force during mounting. Please refer to the following precautions and recommendations.
 - (a) Set and adjust the bottom dead center of the vacuum nozzles to the upper surface of the PC board after correcting the warp of the PC board.
 - (b) Set the pushing force of the vacuum nozzle during mounting to 1 to 3 N in static load.
 - (c) For double surface mounting, apply a supporting pin on the rear surface of the PC board to suppress the bending of the PC board in order to minimize the impact of the vacuum nozzles. Typical examples are shown in the table below secondary.
 - (d) Adjust the vacuum nozzles so that their bottom dead center during mounting is not too low.

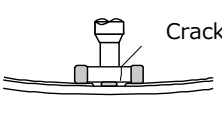
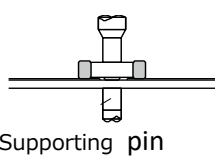
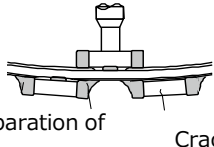
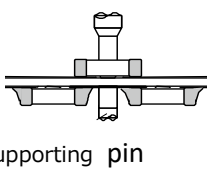
| Item | Prohibited mounting | Recommended mounting |
|-------------------------|--|---|
| Single surface mounting |  Crack |  Supporting pin The supporting pin does not necessarily have to be positioned |
| Double surface mounting |  Separation of Crack |  Supporting pin |

- (4) The closing dimensions of the positioning chucks shall be controlled. Maintenance and replacement of positioning chucks shall be performed regularly to prevent chipping or cracking of the Varistors caused by mechanical impact during positioning due to worn positioning chucks.
- (5) Maximum stroke of the nozzle shall be adjusted so that the maximum bending of PC board does not exceed 0.5 mm at 90 mm span. The PC board shall be supported by an adequate number of supporting pins.

4. Selection of Soldering Flux

Soldering flux may seriously affect the performance of the Varistors. Please confirm enough whether the soldering flux have an influence on performance of the Varistors or not, before using.

5. Soldering

5.1 Flow Soldering

When conducting flow soldering, stress from abrupt temperature change is applied to the Varistors, so the temperature, especially temperature of solder should be controlled very carefully. Varistors should not be subjected to abrupt temperature change because it causes occurrence of thermal cracks as a result of excessive thermal stress inside of the Varistors from flow soldering. You should be careful to temperature difference. Therefore it is essential that soldering process follow these recommended conditions.

- (1) Application of Soldering flux :
The soldering flux shall be applied to the mounted Varistors thinly and uniformly by foaming method.
- (2) Preheating : Conduct sufficient pre-heating, and make sure that the temperature difference between solder and Varistors' surface is 150 °C or less.
- (3) Immersion into Soldering bath :
The Varistors shall be immersed into a soldering bath of 240 to 260 °C for 3 to 5 seconds.
- (4) Gradual Cooling : After soldering, avoid rapid cooling (forced cooling) and conduct gradual cooling, so that thermal cracks do not occur.
- (5) Flux Cleaning : When the Varistors are immersed into a cleaning solvent, be sure that the surface temperatures of devices do not exceed 100 °C.
- (6) Performing flow soldering once under the conditions shown in the figure below
[Recommended profile of Flow soldering (Ex.)] will not cause any problems.
However, pay attention to the possible warp and bending of the PC board.

Recommended profile of Flow Soldering (Ex.)

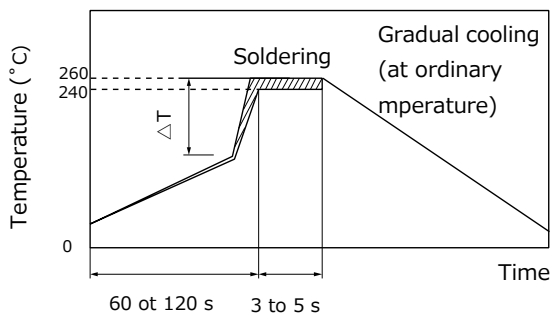

<ΔT: Allowable temperature difference>

| Size/EIA | Temp. Tol. |
|----------|------------|
| 0603 | T ≤ 150 °C |

For products specified in individual specifications, avoid flow soldering.

5.2 Reflow Soldering

The reflow soldering temperature conditions are composed of temperature curves of Preheating, Temp. rise, Heating, Peak and Gradual cooling. Large temperature difference inside the Varistors caused by rapid heat application to the Varistors may lead to excessive thermal stresses, contributing to the thermal cracks. The Preheating temperature requires controlling with great care so that tombstone phenomenon may be prevented.

Recommended profile of Reflow Soldering (Ex.)

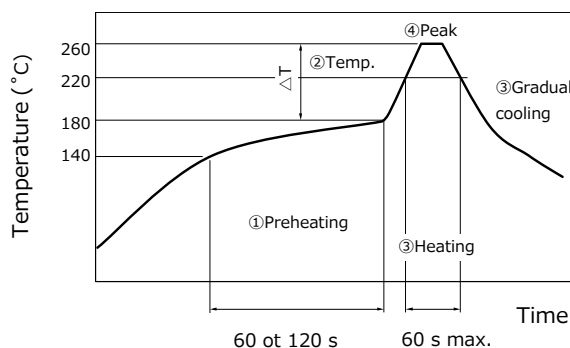

| Item | Temperature | Period or Speed |
|-------------------|-------------------------------|-----------------|
| ① Preheating | 140 to 180 °C | 60 to 120 s |
| ② Temp. rise | Preheating temp to Peak temp. | 2 to 5 °C / s |
| ③ Heating | 220 °C min. | 60 s max. |
| ④ Peak | 260 °C max. | 10 s max. |
| ⑤ Gradual cooling | Peak temp. to 140 °C | 1 to 4 °C / s |

| Size/EIA | Temp. Tol. |
|--------------|------------|
| 0201 to 0805 | T ≤ 150 °C |

ΔT : Allowable temperature difference $\Delta T \leq 150$ °C

The rapid cooling (forced cooling) during Gradual cooling part should be avoided, because this may cause defects such as the thermal cracks, etc. When the Varistors are immersed into a cleaning solvent, make sure that the surface temperatures of the devices do not exceed 100 °C. Performing reflow soldering twice under the conditions shown in the figure above [Recommended profile of Flow soldering (Ex.)] will not cause any problems.

However, pay attention to the possible warp and bending of the PC board.

Recommended soldering condition is for the guideline for ensuring the basic characteristics of the components, not for the stable soldering conditions. Conditions for proper soldering should be set up according to individual conditions. The temperature of this product at the time of mounting changes depending on mounting conditions, therefore, please confirm that Product surface becomes the specified temperature when mounting it on the end product.

5.3 Hand Soldering

Hand soldering typically causes significant temperature change, which may induce excessive thermal stresses inside the Varistors, resulting in the thermal cracks, etc. In order to prevent any defects, the following should be observed.

- Control the temperature of the soldering tips with special care.
- Avoid the direct contact of soldering tips with the Varistors and/or terminal electrodes.
- Do not reuse dismantled Varistors.

(1) Condition 1 (with preheating)

- Soldering : Use thread solder ($\phi 1.0$ mm or below) which contains flux with low chlorine, developed for precision electronic equipment.
- Preheating : Conduct sufficient preheating, and make sure that the temperature difference between solder and Varistors' surface is 150 °C or less.
- Temperature of Iron tip: 300 °C max.
(The required amount of solder shall be melted in advance on the soldering tip.)
- Gradual cooling : After soldering, the Varistors shall be cooled gradually at room temperature.

Recommended profile of Hand soldering (Ex.)

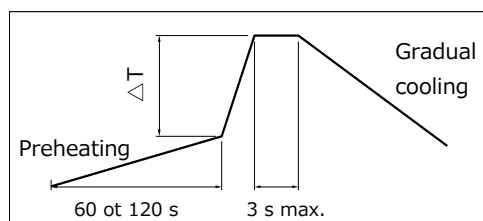

ΔT : Allowable temperature difference $\Delta T \leq 150$ °C

(2) Condition 2 (without preheating)

Hand soldering can be performed without preheating, by following the conditions below:

- (a) Soldering iron tip shall never directly touch the ceramic and terminal electrodes of the Varistors.
- (b) The lands are sufficiently preheated with a soldering iron tip before sliding the soldering iron tip to the terminal electrodes of the Varistors for soldering.

Conditions of Hand soldering without preheating

| Item | Condition |
|--------------------------------------|-------------|
| Temperature of Iron tip | 270 °C max. |
| Wattage | 20 W max. |
| Shape of Iron tip | ∅ 3 mm max. |
| Soldering time with a soldering iron | 3 s max. |

6. Post Soldering Cleaning

6.1 Cleaning solvent

Soldering flux residue may remain on the PC board if cleaned with an inappropriate solvent. This may deteriorate the performance of Varistors, especially insulation resistance.

6.2 Cleaning conditions

Inappropriate cleaning conditions such as insufficient cleaning or excessive cleaning may impair the electrical characteristics and reliability of the Varistors.

(1) Insufficient cleaning can lead to :

- (a) The halogen substance found in the residue of the soldering flux may cause the metal of terminal electrodes to corrode.
- (b) The halogen substance found in the residue of the soldering flux on the surface of the Varistors may change resistance values.
- (c) Water-soluble soldering flux may have more remarkable tendencies of (a) and (b) above compared to those of rosin soldering flux.

(2) Excessive cleaning can lead to :

- (a) When using ultrasonic cleaner, make sure that the output is not too large, so that the substrate will not resonate. The resonance causes the cracks in Varistors and/or solders, and deteriorates the strength of the terminal electrodes. Please follow these conditions for Ultrasonic cleaning:
 - Ultrasonic wave output : 20 W/L max.
 - Ultrasonic wave frequency : 40 kHz max.
 - Ultrasonic wave cleaning time : 5 min. max.

6.3 Contamination of Cleaning solvent

Cleaning with contaminated cleaning solvent may cause the same results as that of insufficient cleaning due to the high density of liberated halogen.

7. Inspection Process

The pressure from measuring terminal pins might bend the PCB when implementing circuit inspection after mounting Varistors on PCB, and as a result, cracking may occur.

- (1) Mounted PC boards shall be supported by an adequate number of supporting pins on the back with bend settings of 90 mm span 0.5 mm max.
- (2) Confirm that the measuring pins have the right tip shape, are equal in height, have the right pressure and are set in the correct positions. The following figures are for your reference to avoid bending the PC board.

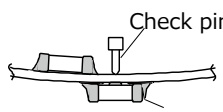
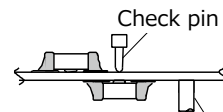
| Item | Prohibited mounting | Recommended mounting |
|---------------------|---|---|
| Bending of PC board |  <p>Separated, Crack</p> |  <p>Supporting pin</p> |

8. Protective Coating

Make sure characteristics and reliability when using the resin coating or resin embedding for the purpose of improvement of humidity resistance or gas resistance, or fixing of parts because failures of a thermistors such as 1) ,2) and 3) may be occurred.

- (1) The solvent which contained in the resin permeate into the Varistors, and it may deteriorate the characteristic.

- (2) When hardening the resin, chemical reaction heat (curing heat generation) happen and it may occurs the infection to the Varistors.
- (3) The lead wire might be cut down and the soldering crack might be happen by expansion or contraction of resin hardening.

9. Dividing/Breaking of PC Boards

- (1) Please be careful not to stress the substrate with bending/twisting when dividing, after mounting components including Varistors. Abnormal and excessive mechanical stress such as bending or torsion shown below can cause cracking in the Varistors.

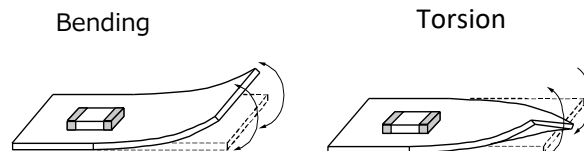

- (2) Dividing/Breaking of the PC boards shall be done carefully at moderate speed by using a jig or apparatus to prevent the Varistors on the boards from mechanical damage.
- (3) Examples of PCB dividing/breaking jigs: The outline of PC board breaking jig is shown below. When PC board are broken or divided, loading points should be close to the jig to minimize the extent of the bending. Also, planes with no parts mounted on should be used as plane of loading, in order to prevent tensile stress induced by the bending, which may cause cracks of the Varistors or other parts mounted on the PC boards.

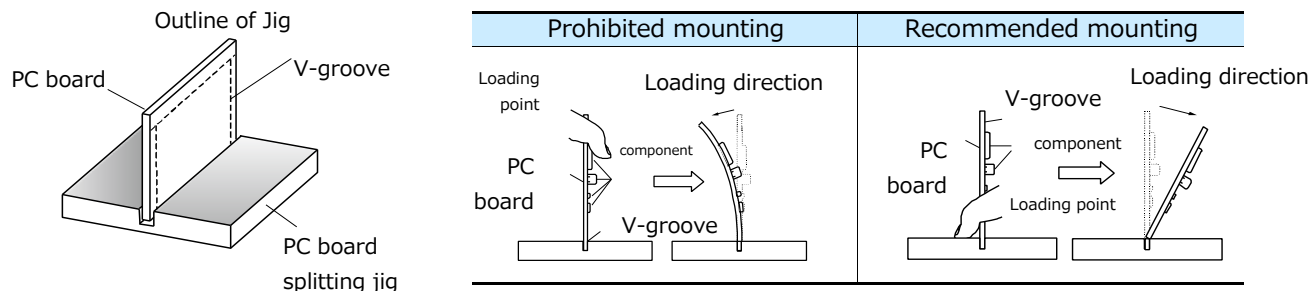

10. Mechanical Impact

- (1) The Varistors shall be free from any excessive mechanical impact. The Varistor body is made of ceramics and may be damaged or cracked if dropped. Never use a Varistor which has been dropped; their quality may already be impaired, and in that case, failure rate will increase.
- (2) When handling PC boards with Varistors mounted on them, do not allow the Varistors to collide with another PC board. When mounted PC boards are handled or stored in a stacked state, the corner of a PC board might strike Varistors, and the impact of the strike may cause damage or cracking and can deteriorate the withstand voltage and insulation resistance of the Varistor.

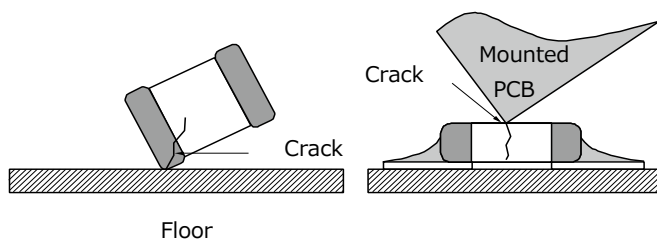

11. Do not reuse this product after removal from the mounting board.

Precautions for discarding

As to the disposal of the Varistors, check the method of disposal in each country or region where the modules are incorporated in your products to be used.

Other

The various precautions described above are typical. For special mounting conditions, please contact us.

Applicable laws and regulations , others

1. This product not been manufactured with any ozone depleting chemical controlled under the Montreal Protocol.
2. This product comply with RoHS(Restriction of the use of certain Hazardous Substance in electrical and electronic equipment) (DIRECTIVE 2011/65/EU and 2015/863/EU).
3. All the materials used in this part are registered material under the Law Concerning the Examination and Regulation of Manufacture, etc. of Chemical Substance.
4. If you need the notice by letter of "A preliminary judgement on the Laws of Japan foreign exchange and Foreign Trade Control", be sure to let us know.
5. These products are not dangerous goods on the transportation as identified by UN (United nations) numbers or UN classification.
6. The technical information in this catalog provides example of our products' typical operations and application circuit. We do not guarantee the non-infringement of third party's intellectual property rights and we do not grant any license, Right or interest in our intellectual property.

CAUTION AND WARNING

1. The electronic components contained in this catalog are designed and produced for use in home electric appliances, office equipment, information equipment, communications equipment, and other general purpose electronic devices. Before use of any of these components for equipment that requires a high degree of safety, such as medical instruments, aerospace equipment, disaster-prevention equipment, security equipment, vehicles (automobile, train, vessel), please be sure to contact our sales representative corporation.
2. When applying one of these components for equipment requiring a high degree of safety, no matter what sort of application it might be, be sure to install a protective circuit or redundancy arrangement to enhance the safety of your equipment. In addition, please carry out the safety test on your own responsibility.
3. When using our products, no matter what sort of equipment they might be used for, be sure to make a written agreement on the specifications with us in advance.
4. Technical information contained in this catalog is intended to convey examples of typical performances and or applications and is not intended to make any warranty with respect to the intellectual property rights or any other related rights of our company or any third parties nor grant any license under such rights.
5. In order to export products in this catalog, the exporter may be subject to the export license requirement under the Foreign Exchange and Foreign Trade Law of Japan.
6. No ozone-depleting substances (ODSs) under the Montreal Protocol are used in the manufacturing processes of Automotive & Industrial Systems Company, Panasonic Corporation.

● Please contact

● Factory

Device Solutions Business Division
Industrial Solutions Company

Panasonic[®]

1006 Kadoma, Kadoma City, Osaka 571-8506,
JAPAN

The information in this catalog is valid as of November 2020.

单击下面可查看定价，库存，交付和生命周期等信息

[>>Panasonic\(松下\)](#)