

## Chip Inductors

Series: Chip

Type: RE, ND, NC, NA, FD,  
FC, FA, SA, PB, PC, PA



Non-winding (RE) and wire wound types chip inductors for automatic mounting and high-density mounting.

**Industrial property:** Patents 4.

■ Features

- High Q
- Good for mounting
- Allowable range (1.5 nH to 1,000 μH)

■ Recommended Applications

- CTV, VTR, HIC, HDD, FDD, cordless telephones, portable telephones, pagers, video cameras

■ Explanation of Part Numbers

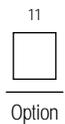
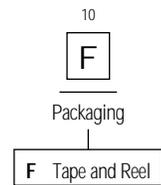
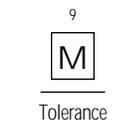
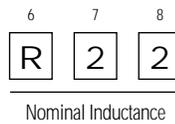
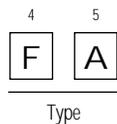
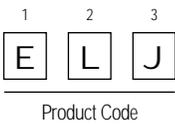

Types	Style				
	E 1608 (0603)	D 2012 (0805)	C 2520 (1008)	A 3225 (1210)	B 4532 (1812)
Coreless	RE	ND	NC	NA	—
Regular	—	FD	FC	FA	FB
Shield	—	—	—	SA	—
Power	—	—	PC	PA	—

Size unit: mm (inch)

2N2	→	2.2 nH
22N	→	22 nH
R22	→	0.22 μH
2R2	→	2.2 μH
220	→	22 μH
221	→	220 μH
102	→	1000 μH

D	±0.3 nH
J	±15%
K	±10%
M	±20%

■ Inductance, Size Guide

Type Name		L Value (μH)						Notes
		0.001	0.01	0.1	1.0	10	100	
Non-Magnetic Core (Ceramic, Resin, etc.)	1608 (0603) RE Refer to EL8							<ul style="list-style-type: none"> <li>• Low inductance, tight tolerance</li> <li>• Stable L value, against an environmental condition</li> <li>• Suitable for high-frequency circuits</li> </ul>
	2012 (0805) ND Refer to EL9							
	2520 (1008) NA Refer to EL10							
	3225 (1210) NA Refer to EL11							
Normal (Ferrite Core)	2012 (0805) FD Refer to EL11							<ul style="list-style-type: none"> <li>• Suitable for various applications</li> </ul>
	2520 (1008) FC Refer to EL12							
	3225 (1210) FA Refer to EL13							
	3225 (1210) SA Mag. Shield Refer to EL14							
	4532 (1812) FB Refer to EL14							
High Power (Ferrite Core)	2520 (1008) PC Refer to EL15							<ul style="list-style-type: none"> <li>• Low DC resistance and large rated DC current</li> <li>• Suitable for power line as choke coil</li> </ul>
	3225 (1210) PA Refer to EL15							

Size unit: mm (inch)

## Non-Magnetic Core Types RE, ND, NC, NA

■ Examples: Type 1608 (0603) RE

Part No.	Inductance		Q <sup>*1</sup> min. (100 MHz)	Q <sup>*2</sup> Typical (800 MHz)	SRF <sup>*3</sup> min. (MHz)	DCR <sup>*4</sup> max. (Ω)	Rated DC Current max. (mA)
	nH (100 MHz)	Tolerance					
ELJRE1N5DF2	1.5	±0.3 nH	8	47	6000	0.07	500
ELJRE1N8DF2	1.8		8	45	6000	0.08	500
ELJRE2N2DF2	2.2		8	35	6000	0.09	500
ELJRE2N7DF2	2.7		8	35	6000	0.10	500
ELJRE3N3DF2	3.3		9	35	5500	0.12	500
ELJRE3N9JF2	3.9	±5%	9	36	5500	0.15	450
ELJRE4N7JF2	4.7		9	36	4800	0.17	450
ELJRE5N6JF2	5.6		9	36	4600	0.18	430
ELJRE6N8JF2	6.8		9	36	3550	0.20	430
ELJRE8N2JF2	8.2		9	36	3500	0.28	400
ELJRE10NJF2	10		10	37	2800	0.32	400
ELJRE12NJF2	12		10	37	2800	0.35	400
ELJRE15NJF2	15		10	38	2500	0.41	350
ELJRE18NJF2	18		10	39	2300	0.45	350
ELJRE22NJF2	22		10	40	2000	0.50	300
ELJRE27NJF2	27		10	41	2000	0.55	300
ELJRE33NJF2	33		10	40	1800	0.60	300
ELJRE39NJF2	39		11	39	1800	0.80	300
ELJRE47NJF2	47		11	38	1800	0.95	250
ELJRE56NJF3	56		12	35	1800	1.20	250
ELJRE68NJF3	68	12	35	1500	1.30	250	
ELJRE82NJF3	82	12	33	1500	1.50	250	
ELJRE10JF3	100	12	30	1300	1.80	200	

\*<sup>1</sup>Test instrument   \*<sup>1</sup> HP4191A   \*<sup>2</sup> HP4291A   \*<sup>3</sup> Self-resonant frequency   \*<sup>4</sup> DC resistance

■ Q-Frequency Characteristics

Type: RE

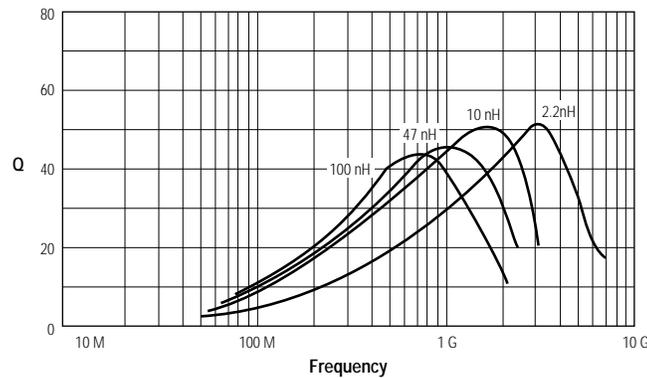

Type: ND

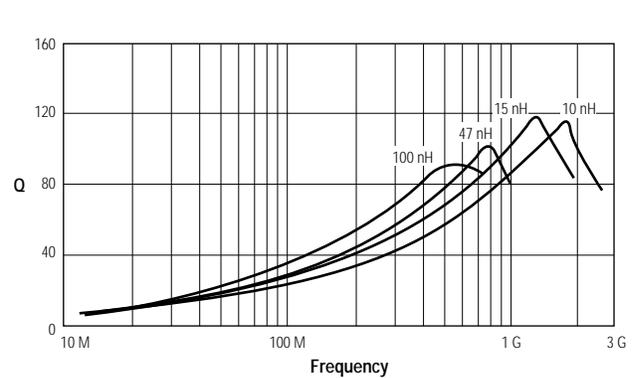

■ Examples: Type 1202 (0805) ND

Part No.	Inductance		Q <sup>*1</sup> min. (100 MHz)	L • Q Test-Frequency (100 MHz)	SRF <sup>*2 *3</sup> min. (MHz)	R DC ±30% (Ω)	IDC max. (mA)		
	nH (100 MHz)	Tolerance							
ELJND10NKF	10	± 10%	10	100	2500	0.14	540		
ELJND12NKF	12				2500	0.18	535		
ELJND15NKF	15		12		2500	0.18	520		
ELJND18NKF	18				2000	0.22	480		
ELJND22NKF	22		15		100	2000	0.22	465	
ELJND27NKF	27					1800	0.26	455	
ELJND33NJ/KF	33					1500	1500	0.30	395
ELJND39NJ/KF	47						1500	0.31	390
ELJND47NJ/KF	56					1000	1000	0.35	385
ELJND56NJ/KF	68						800	0.39	360
ELJND68NJ/KF	82	800		800		0.44	340		
ELJND82NJ/KF	82			800		0.48	330		
ELJNDR10J/KF	100	± 5% ± 10%	8	25.2	800	0.66	2.85		
ELJNDR12J/KF	120				600	0.76	275		
ELJNDR15J/KF	150		10		25.2	600	1.13	230	
ELJNDR18J/KF	180					600	1.24	195	
ELJNDR22J/KF	220					500	1.41	170	
ELJNDR27J/KF	270					300	1.41	170	
ELJNDR33J/KF	330					200	1.66	160	
ELJNDR39J/KF	390					150	1.82	150	
ELJNDR47J/KF	470					150	1.97	145	
ELJNDR56J/KF	560					100	2.07	140	
ELJNDR68J/KF	680	100	2.32	130					
ELJNDR82J/KF	820	80	2.60	125					
ELJND1ROJ/KF	1000	8	7.96	80	2.98	120			

\* Test instrument \*<sup>1</sup> HP4191A \*<sup>2</sup> HP8753B \*<sup>3</sup> Self-resonant frequency

■ Examples: Type 2520 (1008) NC

Part No.	Inductance		Q min.	L • Q Test-Frequency MHz	SRF* MHz (min.)	DCR** Ω max.	Rated DC Current mA max.			
	μH	Tolerance								
ELJNC10NKF	0.010	± 10%	10	100	2500	0.32	280			
ELJNC12NKF	0.012				2200	0.34	270			
ELJNC15NKF	0.015				1800	0.38	255			
ELJNC18NKF	0.018				1550	0.40	250			
ELJNC22NKF	0.022				1350	0.43	240			
ELJNC27NKF	0.027	± 10%	15	100	1150	0.47	230			
ELJNC33NJ/KF	0.033				1000	0.51	220			
ELJNC39NJ/KF	0.039				890	0.55	215			
ELJNC47NJ/KF	0.047				770	0.59	205			
ELJNC56NJ/KF	0.056				670	0.63	200			
ELJNC68NJ/KF	0.068				590	0.68	190			
ELJNC82NJ/KF	0.082				520	0.73	185			
ELJNCR10J/KF	0.10				± 10% ±5%	10	25.2	460	0.80	175
ELJNCR12J/KF	0.12							400	0.87	170
ELJNCR15J/KF	0.15							340	0.98	160
ELJNCR18J/KF	0.18	300	1.05	155						
ELJNCR22J/KF	0.22	260	1.15	145						
ELJNCR27J/KF	0.27	230	1.25	140						
ELJNCR33J/KF	0.33	200	1.37	135						
ELJNCR39J/KF	0.39	180	1.47	130						
ELJNCR47J/KF	0.47	160	1.58	125						
ELJNCR56J/KF	0.56	145	1.70	120						
ELJNCR68J/KF	0.68	130	1.85	110						
ELJNCR82J/KF	0.82	100	2.10	100						

\*Self-Resonant Frequency \*\* DC Resistance

■ Examples: Type 3225 (1210) NA

Part No.	Inductance			Q		SRF MHz (min.)	DCR Ω max.	Rated DC Current mA Max.			
	μH	Freq. MHZ	Tolerance	min.	Freq. MHZ						
ELJNA47NMF	0.047	100	±20%	10	100	680	0.20	450			
ELJNA56NMF	0.056					600	0.22	420			
ELJNA68NMF	0.068					540	0.25	400			
ELJNA82NMF	0.082					500	0.27	380			
ELJNAR10MF	0.10					450	0.30	360			
ELJNAR12MF	0.12	25.2	±20%	10	25.2	400	0.67	240			
ELJNAR15MF	0.15					350	0.72	230			
ELJNAR18MF	0.18					320	0.81	220			
ELJNAR22KF	0.22	1.0	±10%	10	25.2	280	0.90	210			
ELJNAR27KF	0.27					250	1.0	200			
ELJNAR33KF	0.33					220	1.1	190			
ELJNAR39KF	0.39					200	1.2	180			
ELJNAR47KF	0.47					180	1.4	175			
ELKNAR56KF	0.56					160	1.5	170			
ELJNAR68KF	0.68					150	1.7	155			
ELJNAR82KF	0.82					135	1.9	145			
ELJNA1R0KF	1.0					±5%	13	7.96	120	2.1	125
ELJNA1R2JF	1.2								110	2.3	120
ELJNA1R5JF	1.5								95	2.7	115
ELJNA1R8JF	1.8								85	3.0	110
ELJNA2R2JF	2.2								80	3.2	110
ELJNA2R7JF	2.7								70	3.6	105
ELJNA3R3JF	3.3								62	4.2	100
ELJNA3R9JF	3.9	57	4.4	95							
ELJNA4R7JF	4.7	52	7.7	70							
ELJNA5R6JF	5.6	46	8.7	65							
ELJNA6R8JF	6.8	42	10	60							
ELJNA8R2JF	8.2	38	11	60							

Normal Types FD, FC, FA, SA, FB

■ Examples: Type 3225 (1210) NA

Part No.	Inductance		Q <sup>*1</sup> min. (100 MHz)	L • Q Test-Frequency (MHz)	SRF <sup>*2 *3</sup> min. (MHz)	R DC ±30% (Ω)	IDC max. (mA)
	μH	Tolerance					
ELJFDR82KF	0.81	±10%	8	25.2	370	1.35	190
ELJFD1R0KF	1.0		15	7.96	300	1.56	160
ELJFD1R2KF	1.2				200	1.60	155
ELJFD1R5KF	1.5				100	1.85	150
ELJFD1R8KF	1.8				80	1.95	145
ELJFD2R2KF	2.2				70	2.27	145
ELJFD2R7KF	2.7				60	2.54	140
ELJFD3R3KF	3.3				50	2.84	140
ELJFD3R9KF	3.9				40	2.92	130
ELJFD4R7KF	4.7				30	3.38	130

\*Test instrument \*<sup>1</sup> HP4191A \*<sup>2</sup> HP8753B \*<sup>3</sup> Self-resonant frequency

■ Examples: Type 2520 (1008) FC

Part No.	Inductance		Q min.	L • Q Test-Frequency MHz	SRF* MHz (min.)	DCR** Ω max.	Rated DC Current mA max.	
	μH	Tolerance						
ELJFCR22M/KF	0.22	±20% ±10%		25.2	230	0.70	190	
ELJFCR27M/KF	0.27				210	0.75	180	
ELJFCR33M/KF	0.33				190	0.85	170	
ELJFCR39M/KF	0.39				175	0.95	160	
ELJFCR47M/KF	0.47				160	1.0	155	
ELJFCR56M/KF	0.56				150	1.1	150	
ELJFCR68M/KF	0.68				135	1.25	140	
ELJFCR82M/KF	0.82				125	1.4	130	
ELJFC1R0K/JF	1.0	±10% ±5%	25	7.95	115	0.65	195	
ELJFC1R2K/JF	1.2				100	0.75	180	
ELJFC1R5K/JF	1.5				90	0.85	170	
ELJFC1R8K/JF	1.8				85	0.95	160	
ELJFC1R2K/JF	2.2				80	1.05	155	
ELJFC2R7K/JF	2.7				75	1.2	145	
ELJFC3R3K/JF	3.3				65	1.3	135	
ELJFC3R9K/JF	3.9				60	1.4	130	
ELJFC4R7K/JF	4.7			55	1.55	125		
ELJFC5R6K/JF	5.6			50	1.75	120		
ELJFC6R8K/JF	6.8			45	1.95	115		
ELJFC8R2K/JF	8.2			40	2.2	105		
ELJFC100K/JF	10			20	2.52	32	3.5	80
ELJFC120K/JF	12					30	3.8	75
ELJFC150K/JF	15					28	4.4	70
ELJFC180K/JF	18					25	5.0	65
ELJFC220K/JF	22	22	5.8			60		
ELJFC270K/JF	27	21	6.3			115		
ELJFC330K/JF	33	20	7.1			110		
ELJFC390K/JF	39	18	9.5			90		
ELJFC470K/JF	47	17	11.0			80		
ELJFC560K/JF	56	16	12.1			75		
ELJFC680K/JF	68	15	16.6	70				
ELJFC820K/JF	82	13	19.0	65				
ELJFC101K/JF	100	15	0.796	122	21.0	60		

\*Self-Resonant Frequency \*\* DC Resistance

■ Examples: Type 3225 (1210) FA

Part No.	Inductance		Q min.	L, Q Test-Frequency MHz	SRF* min. (MHz)	DCR** Ω max.	Rated DC Current mA max.	
	μH	Tolerance						
ELJFAR22M/KF2	0.22	±20% ±10%	25	25.2	230	0.29	360	
ELJFAR27M/KF2	0.27				210	0.32	345	
ELJFAR33M/KF2	0.33				190	0.35	330	
ELJFAR39M/KF2	0.39				175	0.39	305	
ELJFAR47M/KF2	0.47				160	0.44	290	
ELJFAR56M/KF2	0.56				150	0.49	275	
ELJFAR68M/KF2	0.68				135	0.55	260	
ELJFAR82M/KF2	0.82				125	0.61	245	
ELJFA1R0K/JF2	1.0	±10% ±5%	30	7.96	115	0.69	230	
ELJFA1R2K/JF2	1.2				100	0.75	215	
ELJFA1R5K/JF	1.5				90	0.75	210	
ELJFA1R8K/JF	1.8				85	0.82	200	
ELJFA2R2K/JF	2.2				80	0.95	190	
ELJFA2R7K/JF	2.7				75	1.1	180	
ELJFA3R3K/JF	3.3				65	1.2	180	
ELJFA3R9K/JF	3.9				60	1.3	175	
ELJFA4R7K/JF	4.7				55	1.5	165	
ELJFA5R6K/JF	5.6				50	1.6	160	
ELJFA6R8K/JF	6.8			45	1.8	150		
ELJFA8R2K/JF	8.2			40	2.0	140		
ELJFA100K/JF	10			25.2	25.2	36	2.1	140
ELJFA120K/JF	12					33	2.5	125
ELJFA150K/JF	15					30	2.8	120
ELJFA180K/JF	18					27	3.3	110
ELJFA220K/JF	22					25	3.7	105
ELJFA270K/JF	27					22	5.0	90
ELJFA330K/JF	33					20	5.6	85
ELJFA390K/JF	39					20	6.4	80
ELJFA470K/JF	47	15	7.0			75		
ELJFA560K/JF	56	15	8.0			70		
ELJFA680K/JF	68	15	9.0	65				
ELJFA820K/JF	82	11	10	60				
ELJFA101K/JF	100	20	0.796	10	10	60		
ELJFA121K/JF	120			10	11	55		
ELJFA151K/JF	150			8	15	50		
ELJFA181K/JF	180			7	17	50		
ELJFA221K/JF	220			7	21	45		

\* Self-resonant frequency \*\* DC resistance

## ■ Examples: Type 3225 (1210) SA

Part No.	Inductance			Q		SRF MHz (min.)	DCR Ω max.	Rated DC Current mA max.		
	μH	Freq. MHz	Tolerance	min.	Freq. MHz					
ELJSA100KF	10	1.0	±10%	40	5.0	30	1.8	18		
ELJSA120KF	12					28	2.0	17		
ELJSA150KF	15					25	2.2	15		
ELJSA180KF	18					23	2.5	13		
ELJSA220KF	22					20	2.8	12		
ELJSA270KF	27					18	3.2	10		
ELJSA330KF	33					17	3.5	10		
ELJSA390KF	39				15	3.8	9			
ELJSA470KF	47				14	4.0	8			
ELJSA560KF	56				13	4.5	7			
ELJSA680KF	68				1.5	40	1.5	12	5.0	6
ELJSA820KF	82							11	6.0	6
ELJSA101KF	100							10	7.0	5
ELJSA121KF	120							9	8.0	5
ELJSA151KF	150	5	9.0	5						
ELJSA181KF	180	5	11.0	5						
ELJSA221KF	220	4	12.0	5						
ELJSA271KF	270	4	14.0	5						

## ■ Examples: Type 4532 (1812) FB

Part No.	Inductance			Q		SRF* MHz (min.)	DCR** Ω max.	Rated DC Current mA max.
	μH	Freq. MHz	Tolerance	min.	Freq. MHz			
ELJFB101K/JF	100	0.1	±10% ±5%	40	2.52	6.7	8.8	105
ELJFB121K/JF	120				1.5	6.1	10	100
ELJFB151K/JF	150					5.5	11	95
ELJFB181K/JF	180				5.1	13	85	
ELJFB221K/JF	220				0.796	4.5	13	85
ELJFB271K/JF	270					4.1	14	80
ELJFB331K/JF	330					3.7	16	75
ELJFB391K/JF	390					3.3	19	70
ELJFB471K/JF	470			30	3.3	31	55	
ELJFB561K/JF	560				2.7	35	50	
ELJFB681K/JF	680				2.5	39	50	
ELJFB821K/JF	820				2.4	45	45	
ELJFB102K/JF	1000			2.1	53	40		

\* Self-resonant frequency \*\* DC resistance

## High Power Types PC, PA

### ■ Examples: Type 2520 (1008) PC

Part No.	Inductance		Q min.	L, Q Test-Frequency MHz	SRF* MHz (min.)	DCR** Ω max.	Rated DC Current mA max.
	μH	Tolerance					
ELJPC1R0MF	1.0	±20%	10	7.96	95	0.45	475
ELJPC1R5MF	1.5				85	0.55	435
ELJPC2R2MF	2.2				65	0.65	390
ELJPC3R3MF	3.3				55	0.85	340
ELJPC4R7MF	4.7				43	1.2	285
ELJPC6R8KF2	6.8	±10%	8	2.52	39	1.3	275
ELJPC100KF	10.0				32	2.2	210
ELJPC120KF	12.0				25	2.7	195
ELJPC150KF	15.0				21	3.2	175
ELJPC220KF	22.0				18	4.0	160
ELJPC330KF	33.0				16	6.5	120

\*Self-Resonant Frequency \*\* DC Resistance

### ■ Examples: Type 3225 (1210) PA

Part No.	Inductance		Q	L, Q Test-Frequency MHz	SRF* MHz (min.)	DCR** Ω max.	Rated DC Current mA max.		
	μH	Tolerance							
ELJPA1R0MF	1.0	±20%	7	7.96	150	0.15	600		
ELJPA1R5MF	1.5				110	0.18	550		
ELJPA2R2MF	2.2				80	0.23	500		
ELJPA3R3MF	3.3				58	0.28	400		
ELJPA4R7MF	4.7				46	0.34	350		
ELJPA6R8MF	6.8				38	0.42	300		
ELJPA100KF	10	±10%	15	2.52	23	0.50	240		
ELJPA120KF	12				21	0.60	230		
ELJPA150KF	15				18	0.74	220		
ELJPA180KF	18				17	0.90	205		
ELJPA220KF	22				15	1.15	185		
ELJPA270KF	27				13	1.45	165		
ELJPA330KF	33				12	1.65	155		
ELJPA390KF	39				11	1.90	145		
ELJPA470KF	47				9.5	2.25	135		
ELJPA560KF	56				8.5	3.30	110		
ELJPA680KF	68				7.5	3.70	105		
ELJPA820KF	82				7.0	4.20	100		
ELJPA101KF	100				20	0.796	6.5	5.00	90
ELJPA121KF	120						6.0	7.00	75
ELJPA151KF	150						5.5	8.00	70
ELJPA181KF	180	5.0	9.50	65					
ELJPA221KF	220	4.0	11.0	60					
ELJPA271KF	270	3.5	14.5	55					
ELJPA331KF	330	3.0	16.0	50					

\*Self-Resonant Frequency \*\* DC Resistance

■ Dimensions in mm (not to scale)

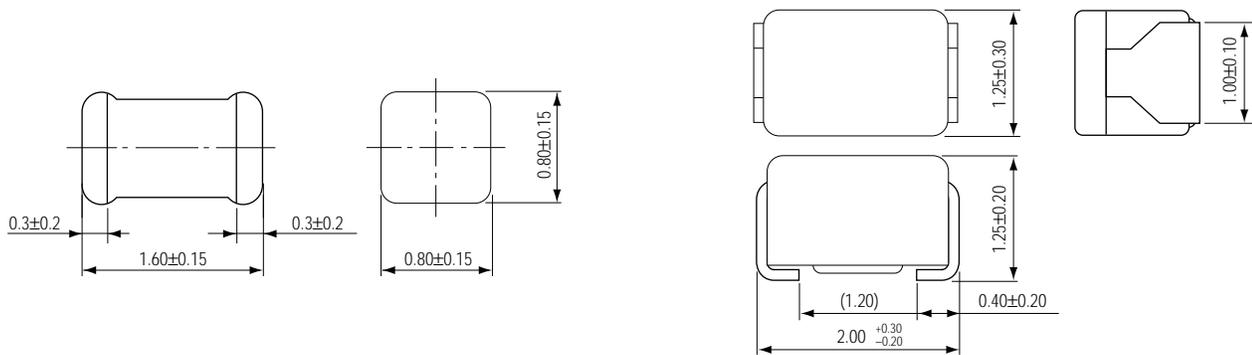

**Type RE**  
(1.6 x 0.8 x 0.8)

**Types ND, FD**  
(2.0 x 1.25 x 1.25)

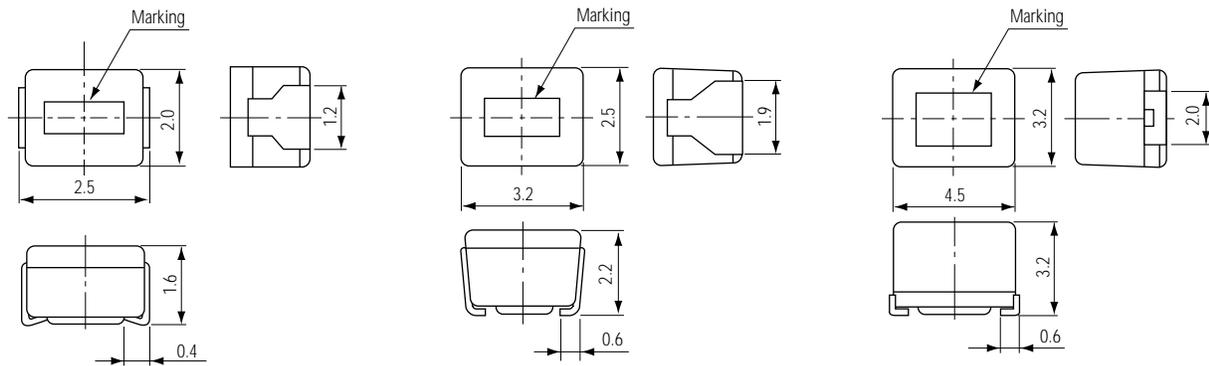

**Types FC, NC, PC**  
(2.5 x 2.0 x 1.6)

**Types FA, SA, NA, PA**  
(3.2 x 2.5 x 2.2)

**Type FB**  
(4.5 x 3.2 x 3.2)

■ Recommended Land Pattern in mm (not to scale)

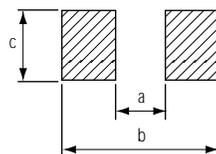

	a	b	c
Type RE	0.8 ~ 1.0	2.0 ~ 2.6	0.7 ~ 0.9
Type □ D	1.0 ~ 1.2	3.0 ~ 3.8	0.9 ~ 1.3
Type □ C	1.4 ~ 1.5	3.5 ~ 4.0	1.2 ~ 1.6
Type □ A	1.6 ~ 2.0	4.0 ~ 4.6	1.9 ~ 2.4
Type FB	2.4 ~ 2.6	5.5 ~ 6.0	2.0 ~ 3.0

■ Embossed Carrier Tape Dimensions in mm (not to scale)  
Types RE, ND, FC, FD, FC, PC

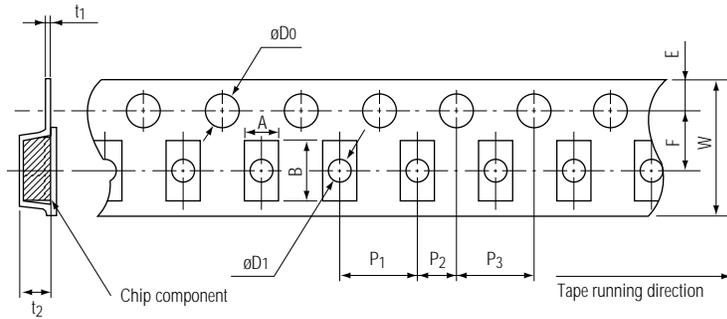

(W = 8mm)

Types NA, FA, SA, PA

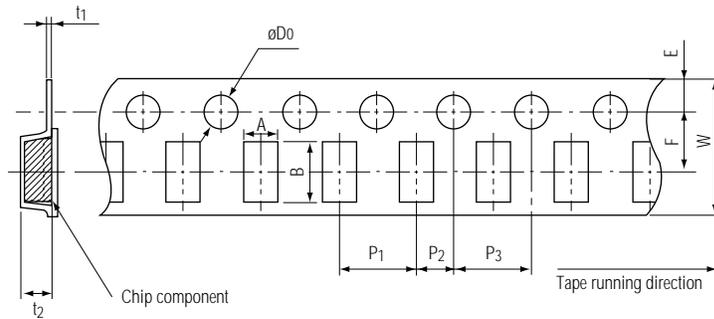

(W = 8mm)

Type FB

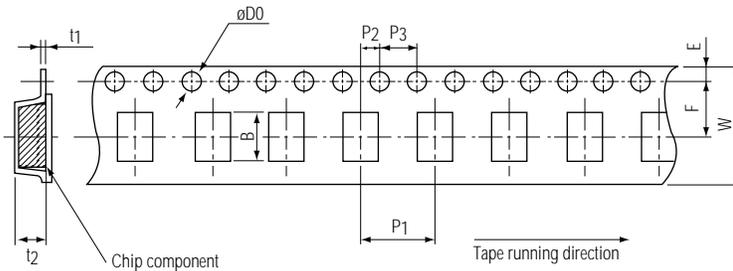

(W = 12mm)

Size	Types	Dimensions										t <sub>1</sub>	t <sub>2</sub>
		A	B	W	F	E	P <sub>1</sub>	P <sub>2</sub>	P <sub>3</sub>	øD <sub>0</sub>	øD <sub>1</sub>		
1608 (0603)	RE	1.0	1.8	8	3.5	1.75	4.0	2.0	4.0	1.5	0.6	(0.27)	1.2
2012 (0805)	ND, FD	1.45	2.25	8	3.5	1.75	4.0	2.0	4.0	1.5	1.0	(0.25)	1.55
2520 (1008)	NC, FC, PC	2.4	2.9	8	3.5	1.75	4.0	2.0	4.0	1.5	1.1	(0.25)	1.85
3225 (1210)	NA, FA, SA, PA	2.8	3.6	8	3.5	1.75	4.0	2.0	4.0	1.5	—	(0.25)	2.4
4532 (1812)	FB	3.6	4.9	12	5.5	1.75	8.0	2.0	4.0	1.5	—	(0.3)	3.5

## ■ Packaging Methods

### Standard Packing Quantity and Mass

Types	Quantity	Mass
RE, ND, FD	3000 pcs.	90 g
NC, FC, PC	2000 pcs.	100 g
NA, FA, SA, PA	2000 pcs.	170 g
FB	500 pcs.	100 g

### Reel Dimensions

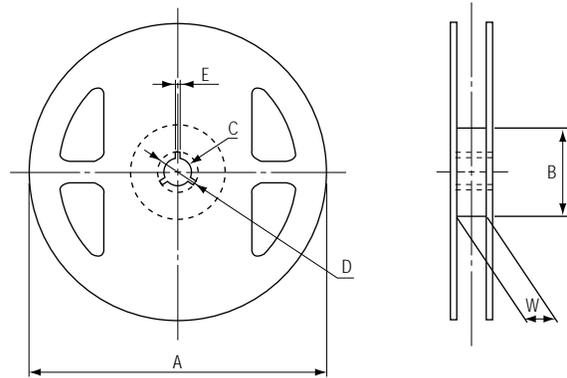

#### Dimensions

##### Types RE, ND, FD, NC, FC, PC, NA, FA, SA, PA

A	B	C	D	E	W
178	60 min.	ø13	21	2.0	9

##### Type FB

A	B	C	D	E	W
178	60 min.	ø13	21	2.0	13

单击下面可查看定价，库存，交付和生命周期等信息

[>>Panasonic\(松下\)](#)